



US00D643561S

(12) **United States Design Patent**  
**Maglica**

(10) **Patent No.:** **US D643,561 S**

(45) **Date of Patent:** **\*\* \*Aug. 16, 2011**

(54) **FLASHLIGHT**

(75) Inventor: **Anthony Maglica**, Ontario, CA (US)

(73) Assignee: **Mag Instrument, Inc.**, Ontario, CA (US)

(\*\*) Term: **14 Years**

(21) Appl. No.: **29/340,085**

(22) Filed: **Jul. 13, 2009**

(51) **LOC (9) Cl.** ..... **26-02**

(52) **U.S. Cl.** ..... **D26/49**

(58) **Field of Classification Search** ..... D26/37,  
D26/38, 39, 44, 45, 46, 49, 51; 362/157,  
362/158, 183, 184, 187, 190, 194-197, 198,  
362/202-208

See application file for complete search history.

(56) **References Cited**

**U.S. PATENT DOCUMENTS**

4,114,187	A	9/1978	Uke	
4,581,686	A	4/1986	Nelson	
D293,482	S	12/1987	Geissler	
4,841,417	A	6/1989	Maglica et al.	
4,864,474	A	9/1989	Maglica	
D308,109	S *	5/1990	Maglica et al.	D26/49
D310,425	S	9/1990	Sharrah	
D315,219	S	3/1991	Brinkmann et al.	
5,207,363	A	5/1993	Duchi, Jr. et al.	
5,331,528	A	7/1994	Chen	
5,461,552	A	10/1995	Tillery	
D371,214	S	6/1996	Terry, Sr.	
D388,524	S	12/1997	Shiau	
D419,254	S *	1/2000	Chiu	D26/49
D450,868	S	11/2001	Maximilian-Yee	
D465,045	S	10/2002	Yamamoto et al.	
6,612,716	B2	9/2003	Kwak	
D489,469	S	5/2004	Liou	
D525,379	S *	7/2006	Maxik et al.	D26/37
D529,643	S	10/2006	Kung	
D532,543	S *	11/2006	Julius et al.	D26/49

(Continued)

**FOREIGN PATENT DOCUMENTS**

JP D1237499 4/2005

(Continued)

**OTHER PUBLICATIONS**

Germany Trademark Office, Certificate of Trademark Registration No. 394 10 799, registered: Sep. 29, 1995, in the name of Mag Instrument, Inc. (2 pages).

(Continued)

*Primary Examiner* — Ian Simmons

*Assistant Examiner* — Carissa C Fitts

(74) *Attorney, Agent, or Firm* — Jones Day

(57) **CLAIM**

The ornamental design for a flashlight, as shown and described.

**DESCRIPTION**

FIG. 1 is a front, top perspective view of the flashlight showing my new design;

FIG. 2 is a rear, bottom perspective view thereof;

FIG. 3 is a top plan view thereof;

FIG. 4 is a front elevational view thereof;

FIG. 5 is a rear elevational view thereof;

FIG. 6 is a front, top perspective view of an alternative embodiment of the flashlight showing my new design;

FIG. 7 is a rear, bottom perspective view thereof;

FIG. 8 is a top plan thereof;

FIG. 9 is a front elevational view thereof; and,

FIG. 10 is a rear elevational view thereof.

The broken line showings in FIGS. 2, 3, 5, 7, 8, and 10 are for illustrative purposes only and form no part of the claimed design.

**1 Claim, 4 Drawing Sheets**

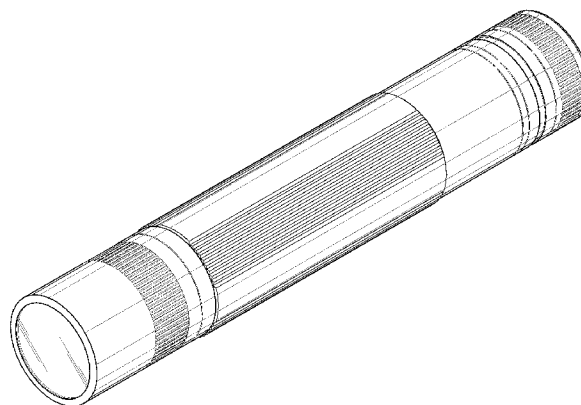
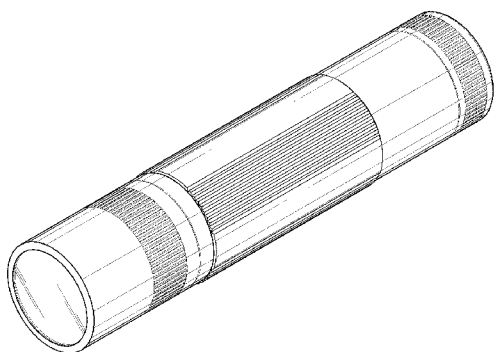

U.S. PATENT DOCUMENTS

D535,417	S *	1/2007	Martin	.....	D26/37
7,220,016	B2	5/2007	Matthews et al.		
D544,120	S	6/2007	Matthews et al.		
D551,368	S *	9/2007	Shiu	.....	D26/37
7,293,893	B2	11/2007	Kim		
D557,840	S *	12/2007	Shiu	.....	D26/37
D560,012	S *	1/2008	Liu	.....	D26/49
D563,007	S	2/2008	Opolka		
D567,416	S *	4/2008	Shiu	.....	D26/37
D568,514	S *	5/2008	Shiu	.....	D26/49
D568,515	S *	5/2008	Liu	.....	D26/49
D578,687	S *	10/2008	Hong	.....	D26/37
D593,239	S	5/2009	Caniparoli		
D593,240	S	5/2009	Caniparoli		
D596,773	S *	7/2009	Liu	.....	D26/49
D600,384	S *	9/2009	Chen	.....	D26/49
D607,591	S *	1/2010	Rivera et al.	.....	D26/49
2003/0189826	A1	10/2003	Yoon		
2006/0039139	A1	2/2006	Maglica et al.		
2010/0039801	A1	2/2010	Pelletier et al.		

FOREIGN PATENT DOCUMENTS

JP	D1245568	7/2005
JP	D1346652	12/2008
TW	395877	1/1988
TW	585721	10/1991
TW	589103	5/1992
TW	D102482	11/1992
TW	D123337	6/1996
TW	D126908	1/1997
TW	429089	12/2008

OTHER PUBLICATIONS

Rayovac® Police Flashlights Advertisement—Jones Day litigation exhibit BRX-342 (3 pages) (Believed to be dated from at least as early as 1990).  
 Photo of a black flashlight labeled Plaintiff’s Exhibit 103 (5 pages) (Believed to be dated from at least as early as 1990).

Photo of a black flashlight with a Coca Cola® can and a ruler for size comparison, marked “5322.” (Believed to be dated from at least as early as 1990).  
 Photo of a black flashlight in assembled and disassembled state with a Coca Cola® can and a ruler for size comparison, marked “12A.” (Believed to be dated from at least as early as 1990).  
 Photo of a black flashlight with a Coca Cola® can and a ruler for size comparison, marked “2584.” (Believed to be dated from at least as early as 1990).  
 Maglite® Product Brochure, Mag Instrument, Inc., 2001 (7 pages).  
 New Zealand Intellectual Property Office, Certificate of Trademark Registration No. 284721, registered: Nov. 13, 1997, in the name of Mag Instrument, Inc. (2 pages).  
 Mag® Product Brochure, Mag Instrument, Inc., 1994 (6 pages).  
 Germany Trademark Office, Certificate of Trademark Registration No. 394 10 799, registered: Sep. 29, 1995, in the name of Mag Instrument, Inc. (2 pages).  
 Photo of Arc® Flashlight Keychain HA LED, 2003, FlashlightMuseum.com (online since Aug. 4, 2003, FM Reference #: AR00002) (1 page).  
 Photo of Peak LED Solutions Solid Brass LED Shasta flashlight, 2007, FlashlightMuseum.com (online since Jun. 30, 2008, FM Reference #: PEA001) (3 pages).  
 Photo of Rayovac® 2 Cell Ribbed Vulcanite Flashlight, 1926, FlashlightMuseum.com (online since May 10, 2007, FM Reference #: RA00146) (3 pages).  
 Rayovac® Police Flashlights Advertisement—Jones Day litigation exhibit BRX-342 (3 pages).  
 Eveready® Automatic Spotlights Advertisement—Jones Day litigation exhibit DX 5824 (15 pages).  
 Photo of a black flashlight labeled Plaintiff’s Exhibit 103 (1 page).  
 Photo of a black flashlight with a Coca Cola® can and a ruler for size comparison, marked “5322.”  
 Photo of a black flashlight in assembled and disassembled state with a Coca Cola® can and a ruler for size comparison, marked “12A.”  
 Photo of a black flashlight with a Coca Cola® can and a ruler for size comparison, marked “2584.”

\* cited by examiner

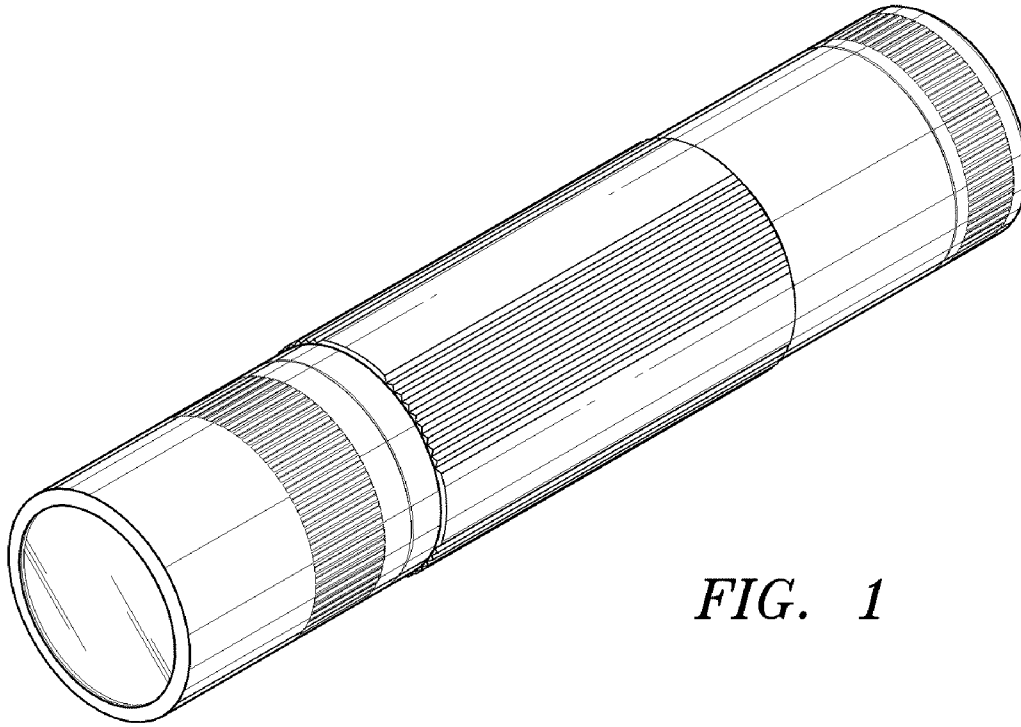

*FIG. 1*

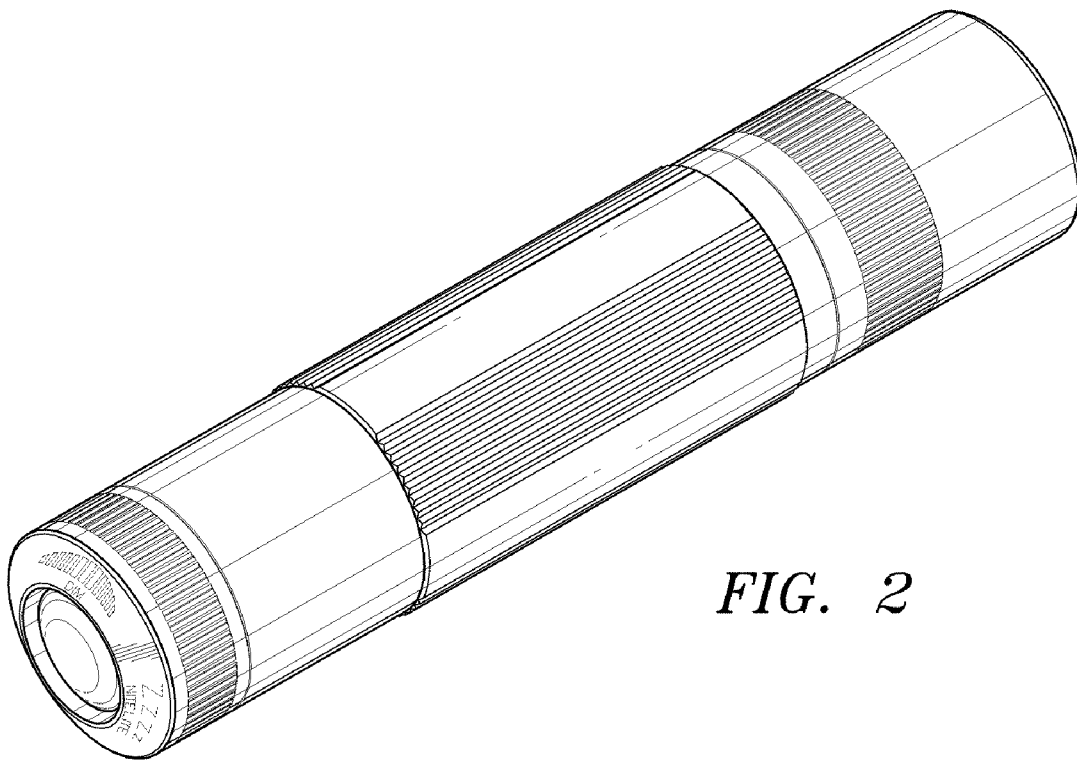

*FIG. 2*

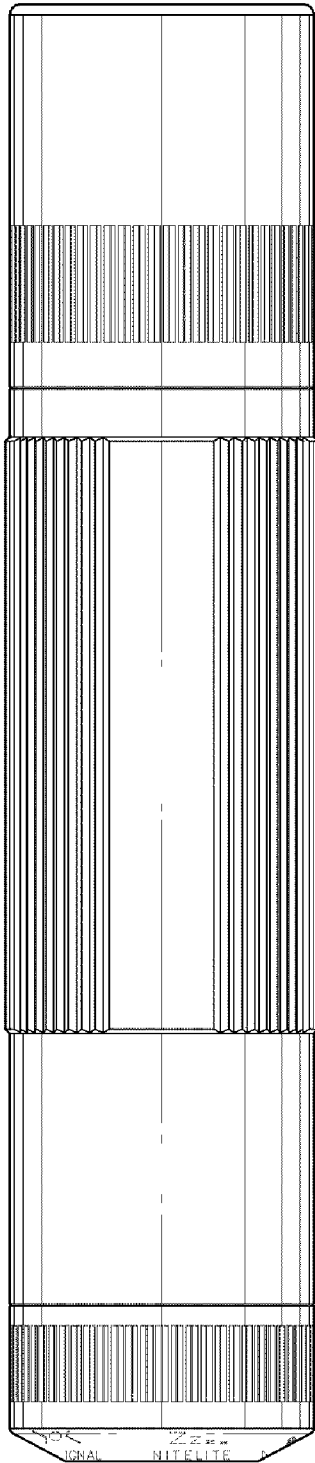

*FIG. 3*

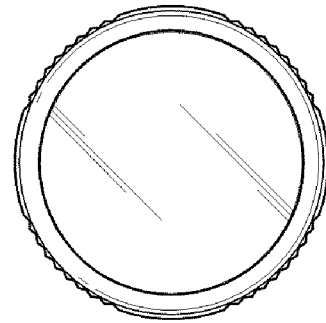

*FIG. 4*

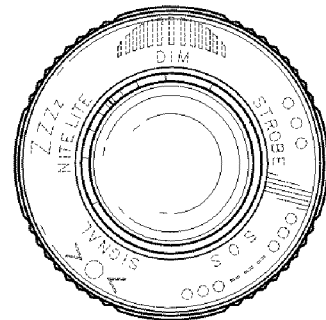

*FIG. 5*

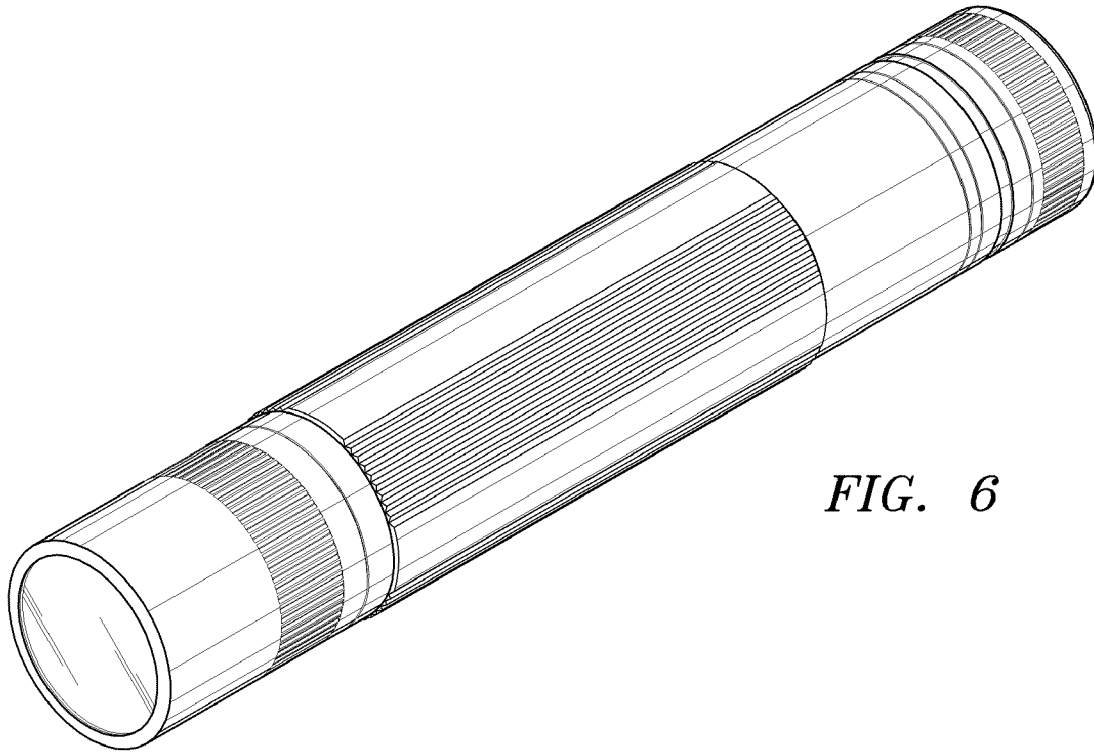

*FIG. 6*

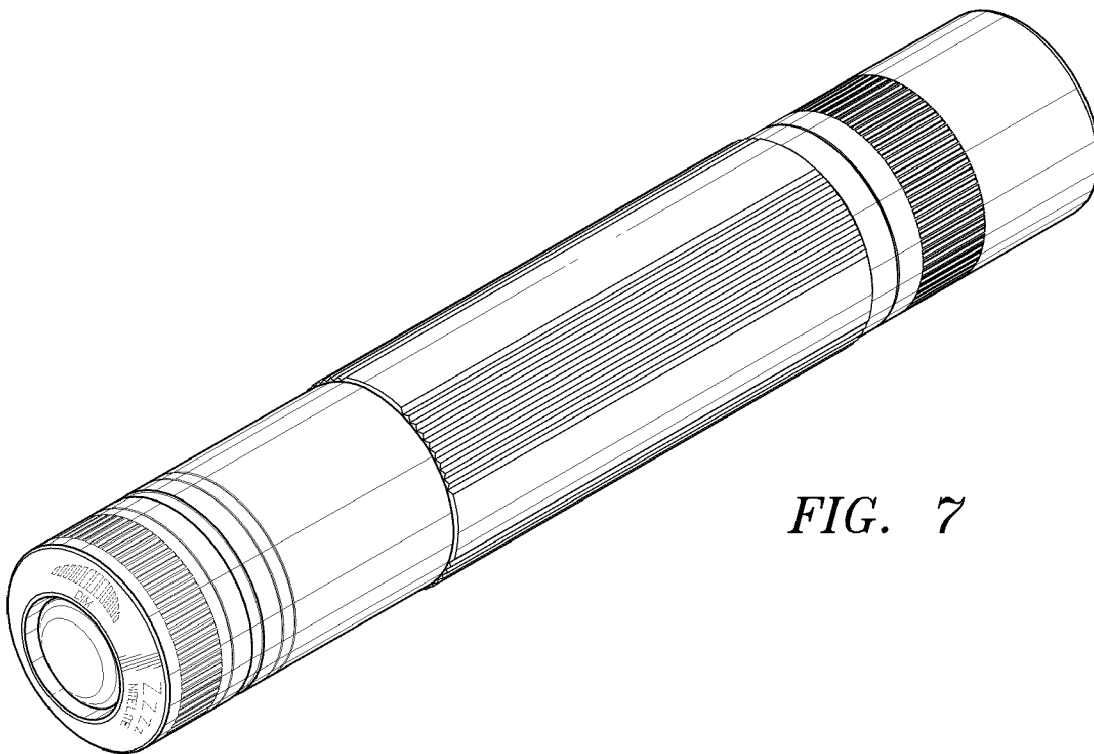

*FIG. 7*

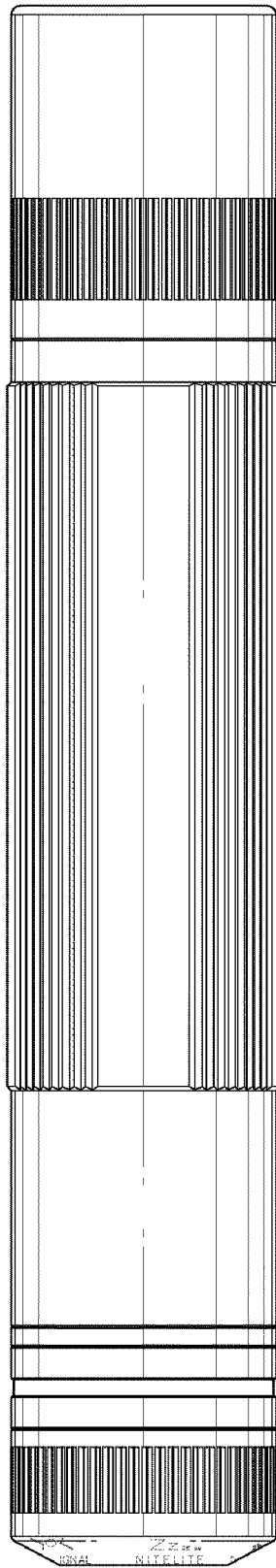

FIG. 8

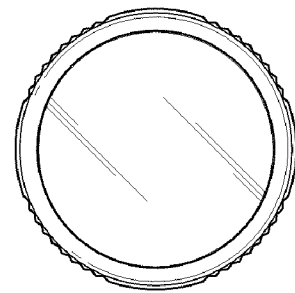

FIG. 9

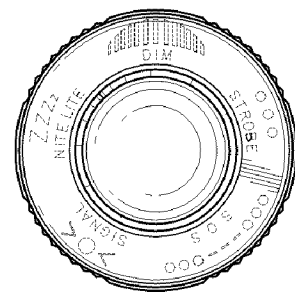

FIG. 10