

Jan. 25, 1966

S. WALLIN ETAL

3,231,165

METHOD AND APPARATUS FOR STABILIZING AN AIR-BORNE WEB

Filed May 14, 1962

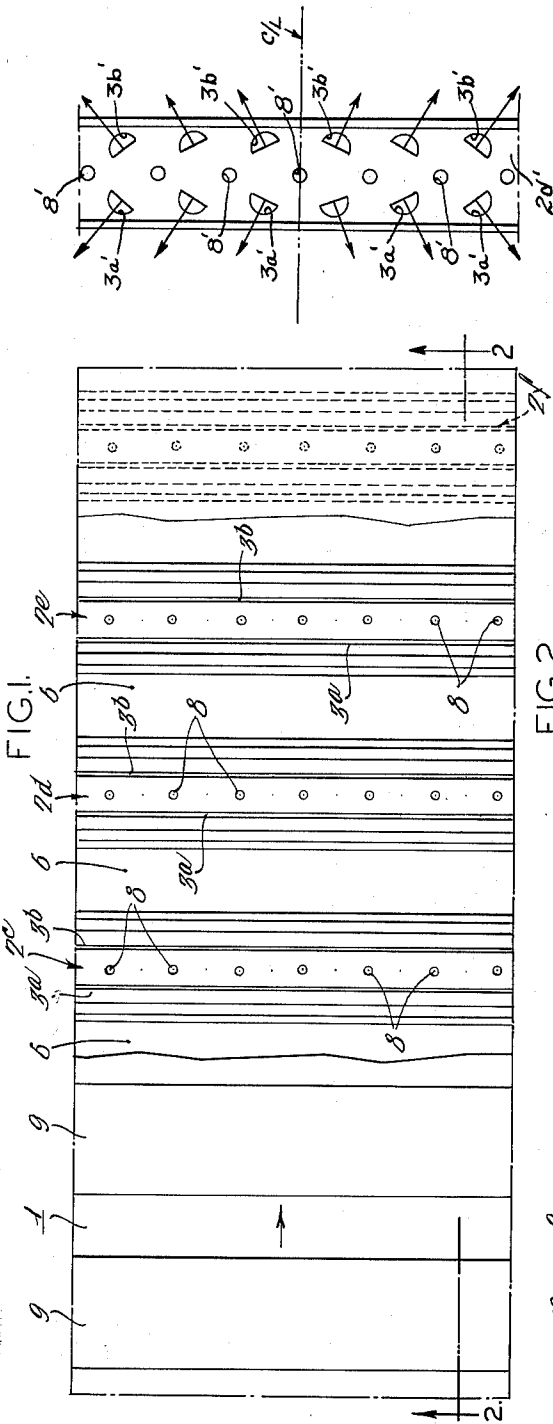

FIG. 1.

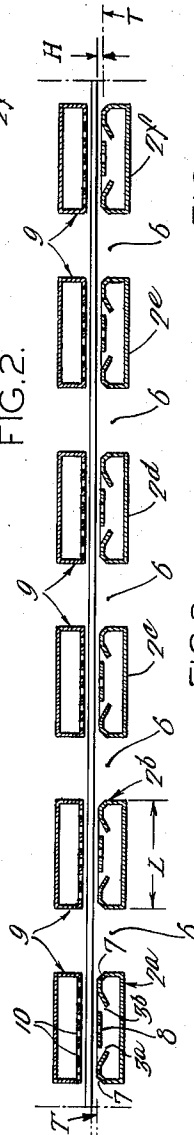

FIG. 2.

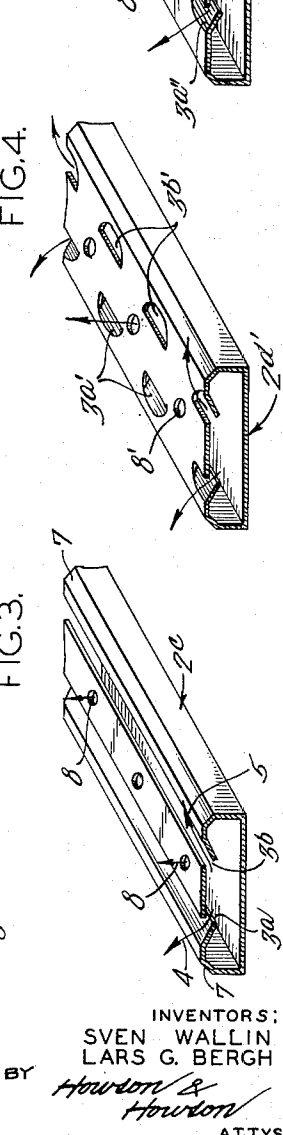

FIG. 3.

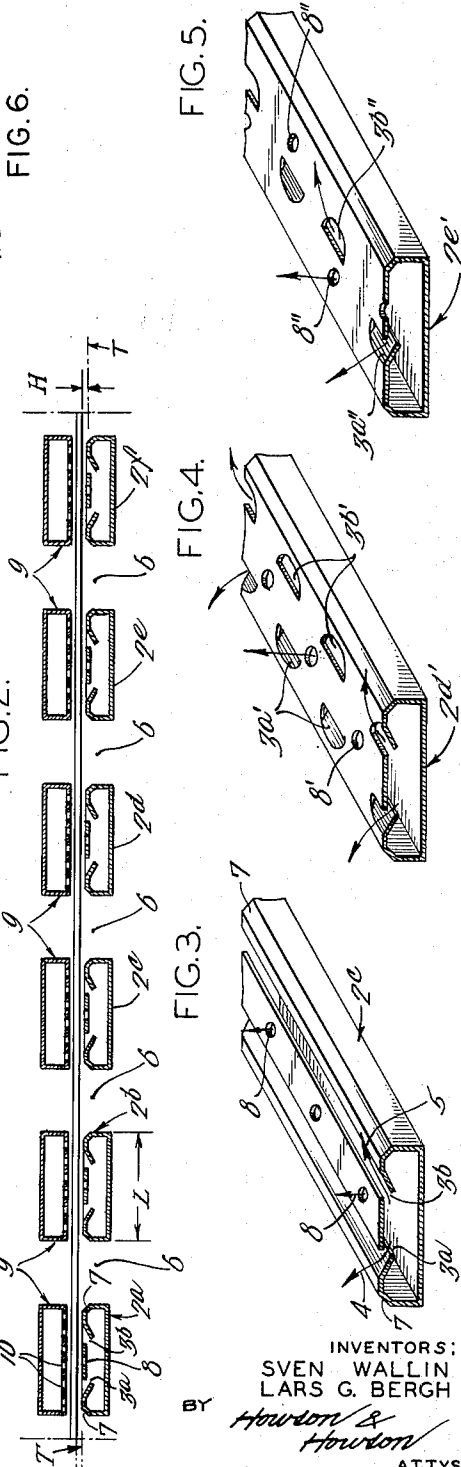

FIG. 4.

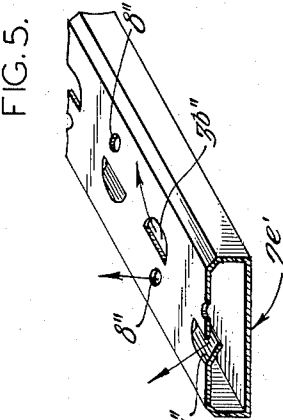

FIG. 5.

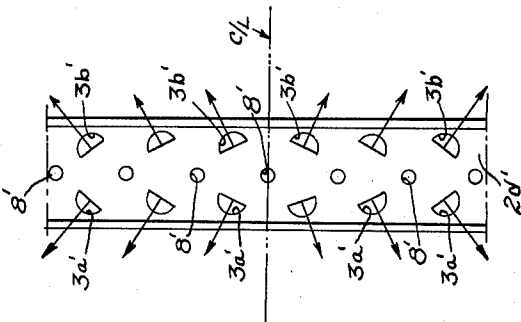

FIG. 6.

INVENTORS:
SVEN WALLIN
LARS G. BERGH
BY
Howdon & Howdon
ATTYS.

3,231,165
METHOD AND APPARATUS FOR STABILIZING AN AIR-BORNE WEB

Sven Wallin, Jonkoping, and Lars G. Bergh, Vaxjo, Sweden, assignors to Aktiebolaget Svenska Flakfabriken, Stockholm, Sweden

Filed May 14, 1962, Ser. No. 195,672

Claims priority, application Sweden, Dec. 2, 1961, 12,046/61

16 Claims. (Cl. 226—97)

The present invention relates to a method for stabilizing a plane, preferably web-shaped material which during its convenience is supported on air or another gaseous medium blown against the material, and to fix the said web at a pre-determined distance from the conveying plane. When material is conveyed in the aforesaid manner, there is always the great problem of causing the web to move in a definite plane without fluttering or wave formation. It was previously known to stabilize a web of uniform material having a preferably relatively great weight per unit area to a certain extent by controlling the jets of gaseous medium supplied to the lower and possibly to the upper surface of the web. It has proved difficult, however, not to say impossible, to stabilize a web in the aforesaid manner when material of varying weight per unit area and particularly of very low weight, for example thin paper, had to be conveyed in this way. According to practical experience, the aforesaid control of the air jets cannot be carried out with the accuracy required in relation to the low net weight of the paper.

It is an object of the present invention to eliminate the aforesaid drawbacks and to obtain complete stabilization of an air-borne web. The invention is characterized in that the gaseous medium is supplied from one or a plurality of distribution boxes disposed adjacent the web, each box having a substantially plane surface facing the web and located in the conveying plane with a length in the conveying direction which considerably exceeds the distance between the web and the conveying plane and is at least twenty times said distance, and in that the gaseous medium is caused to flow out of each distribution box in two jets parallel with the conveying plane, which jets are caused to flow along the aforesaid surface of the distribution box in mutually opposite direction relative the conveying directions.

The method according to the invention is based on the realization of the possibility of obtaining stabilization by utilizing the hydrodynamic effect, according to which a flow between two surfaces gives rise to a force which draws said surfaces towards one another until the distance therebetween becomes so small that the static pressure drop of the flow maintains balance with said force. As a result of the invention, it is thus possible not only to convey webs of material of varying weight in a plant, but also to cause webs of very light weight to move in a fixed plane without fluttering. In certain cases it may be preferable to maintain the stabilizing effect by supplying from each distribution box a smaller portion of the gaseous medium between the said air jets in the form of an air jet perpendicular to the web. For guiding the web and causing a certain stretching of the same in a transverse direction, the opposite air jets may be given an outflow direction which on both sides of the central line of the conveying plane forms an acute angle with the said central line, the said angle preferably being given a value increasing progressively towards the sides of the conveying plane.

The invention relates further to an apparatus for carrying out the aforesaid method, the said apparatus comprising a plurality of distribution boxes disposed in series

in the conveying direction and connected with means supplying air or other gaseous medium, in such a manner, that transverse discharge channels for said medium are formed between the said boxes. The said apparatus is characterized in that each of said distribution boxes has a substantially plane surface facing the web and located in the conveying plane with a length in the conveying direction which considerably exceeds the said distance between the web and the conveying plane and is at least twenty times said distance, and in that each distribution box is provided with outlet openings grouped in rows along the central line of the distribution box perpendicularly to the conveying direction, said ports adapted to cause the medium to flow out in two jets parallel with the conveying plane, which jets are caused to flow along the said substantially plane surface of the distribution box in the same and in the opposite direction respectively relative the conveying direction.

A preferred embodiment of said apparatus is characterized in that each distribution box comprises in addition to the said openings a row of outlet openings located between said first openings, said openings being adapted to direct a smaller portion of the gaseous medium perpendicularly to the web and having a total area which is smaller than the total area of said first openings. All of said outlet openings of the distribution boxes may be formed as long and narrow slots, or the outlet openings for the air jets in mutually opposite directions relative the conveying direction may be a series of so-called eyelid perforations, while the outlet openings located therebetween may be a series of circular holes. In order to prevent disturbances which possibly may be caused by opposite flows from two adjacent distribution boxes, in a preferred embodiment the distribution boxes are provided with rounded or chamfered upper edge portions facing the discharge channels.

In a conveying plant comprising one or a plurality of distribution boxes of the aforesaid construction, a flat material, such as for example paper, will maintain a stable run when being passed over said boxes. Due to the fact that the air jets from each distribution box have opposite directions, the jets give rise to a stretching of the web in its longitudinal direction, thus preventing fluttering of the web. By placing the outlet openings in a suitable manner relative one another and by adjusting the distance between said openings and the edges of the distribution box, for each material a suitable relation between the frictional pressure drop of the air during its passage below the web and the dynamic pressure of the outflowing air at the openings can be obtained to ensure a stable position of the web. In order to eliminate the risk of a detrimental effect by a vacuum created between the aforesaid primary jets—particularly in such cases when the distance between the said openings is relatively great—a smaller portion of the medium may, as mentioned before, be supplied between said air jets in the form of air jets directed perpendicularly to the web. Hereby a still greater freedom of choice in dimensioning the details comprised in the system is obtained. The latter step renders it further possible to increase the total heat transfer to the web when applying the invention in connection with drying or other treatment—due to the possibility of obtaining a higher heat transfer coefficient due to the blowing at a right angle.

The stabilizing effect of the invention may be utilized in plants of the type wherein the airborne web is advanced by means of driven turning or take-up rollers, or where the web only with the help of the medium blown against it is caused to move in the conveying direction by producing a forward force component. In the latter case, the air distribution boxes are provided with a num-

ber of extra openings for the air jets acting in the conveying direction.

The invention will now be described more in detail with reference to the accompanying drawing showing by way of example an embodiment of a plant for conveying air-borne web-shaped material, and different embodiments of air distribution boxes.

In the drawings:

FIG. 1 is a plan view, partly in section, of apparatus embodying the invention;

FIG. 2 is a vertical longitudinal section taken on the line 2—2 of FIG. 1;

FIG. 3 is a perspective view and section of one form of air distribution box;

FIG. 4 is a perspective view and section of a modified form of air distribution box;

FIG. 5 is a perspective view and section of another form of air distribution box.

FIG. 6 is a diagrammatic plan view of a single distribution box showing an air flow pattern.

Referring to the drawing, 1 designates a web to be conveyed air-borne along a conveying plane T—T. In the embodiment shown, the conveying takes place in a substantially horizontal plane, but it may also be made in a vertical or sloping plane. The supporting medium—preferably air—is supplied by a plurality of distribution boxes 2a, 2b, 2c, etc. each having a substantially plane surface facing the web and located in the conveying plane T—T with a length L in the conveying direction which considerably exceeds the intended distance H between the web and the conveying plane and is at least twenty times said distance. In FIG. 2 the arrows marked H indicate this measurement. The thickness of the web is exaggerated for clarity of illustration. Each distribution box is provided with outlet openings 3a, 3b grouped in rows along the central line of the distribution box at a right angle to the conveying direction, the openings being designed in such a manner that the air supplied to the distribution boxes by means of fans (not shown) is caused to flow out in two jets parallel with the conveying plane, which jets are indicated in the drawing by the arrows 4 and 5, and caused to flow in mutually opposite directions relative to the conveying direction along the aforesaid surface of the distribution box to discharge channels 6 provided between the distribution boxes. The said discharge channels are connected with the inlet of the fans by return channels (not shown) or they may communicate directly with the environment. In order to prevent disturbances which may be caused when air jets from two adjacent distribution boxes meet at the discharge channels, the distribution boxes may be provided with rounded or chamfered upper edge portions 7 facing the discharge channels. As appears from distribution box 2a, the outlet openings 3a and 3b may be long and narrow slots or, as in the case of distribution box 2d, they may be so-called eye-lid perforations. The said outlet openings 3a', 3b' may be located as shown at 2d', with the series of openings on both sides of and at a distance from the central line of the distribution box, but the openings 3a'', 3b'' may also, as shown at 2e', be placed substantially along the same line facing alternately opposite directions. As shown in the detail FIGURES 3, 4 and 5 the distribution boxes may also be provided with second outlet openings 8, 8', 8'' having a total area which is smaller than the total area of the aforesaid first outlet openings and adapted to direct a smaller portion of the air at a right angle to web 1. When the web is to be dried or conditioned during its conveying, air is preferably supplied even to the opposite surface of the web. This air which is pre-treated in a manner required, may be supplied by distribution boxes 9 provided with series of outlet openings 10 which may be designed as to direct the air jets perpendicularly or obliquely downwards against the web. In the embodiment shown, the invention is applied to the conveying of a coherent web, but it may even be utilized

for conveying sheet or board material as well as piece goods having a plane surface of sufficient extent.

FIG. 6 illustrates the arrangement described in the introduction wherein the air jets on opposite sides of the center line of the conveying plane, marked C/L, form an acute angle with the center line in opposite directions to cause a transverse stretching of the web. The view illustrates the special case where the angles increase progressively on each side but from this the simple form where the angles do not increase can be understood. The form of openings and reference characters in FIG. 6 are the same as in FIG. 4.

In view of the fact that the web supplied with air according to the invention in the aforescribed manner is not only stabilized but also fixed at a definite distance adjacent the conveying plane, a plant of the type described above may be modified in such a manner, that the distribution boxes 2a, 2b, 2c etc. are placed above the web instead of below the web, as shown, in the same manner utilizing the abovementioned effect tending to draw the web towards said boxes, the lower sides of which constitute the conveying plane. Without departing from the invention idea the distributing boxes may be disposed so that they together form a curved conveying plane or a conveying plane of any shape.

What we claim is:

1. A method for stabilizing and transporting web or sheet like material along a conveying path comprising the steps of; providing a guiding plane for said material, supplying said material with a gaseous medium at a plurality of spaced points along said conveying path from said conveying plane, directing, at each of said spaced points jets of said gaseous medium in two opposite directions substantially parallel to said material whereby a film of medium is formed between said material and said guiding plane, and discharging said gaseous medium from between said material and said guiding plane at other spaced locations between said spaced points.

2. The method as set forth in claim 1 including the step of; positioning said spaced points and said other discharging locations from each other a distance along said conveying path at least ten times the thickness of said film between said guiding plane and said material.

3. The method as set forth in claim 1 including the step of; controlling the flow of gaseous medium supplied at a plurality of spaced points to equalize and balance the longitudinal forces on the traveling web-like material.

4. The method as set forth in claim 1 including the step of; supplying an additional quantity of medium perpendicularly toward said web-like material.

5. The method as set forth in claim 1 wherein said directing step includes directing the jets of said medium substantially parallel to the direction of movement of said material.

6. The method as set forth in claim 5 including the step of; setting said jets of gaseous medium discharged from said space points at a progressively increased angle with respect to the center line of the conveying path, and outwardly therefrom.

7. Apparatus for transporting web or sheet like materials comprising a plurality of longitudinally spaced, transversely oriented, distribution boxes, gaseous medium supply means connected to said distribution boxes, each of said boxes having a substantially plane wall portion facing said material, each of said wall portions having pairs of oppositely directed medium outlets arranged therein in rows, each of said rows being parallel to the center line of their respective distribution box, at right angles to the conveying path, and having means to impart to medium flowing therefrom a direction parallel to said material, and discharge openings formed by the spaces between said boxes and providing return ducts for said gaseous medium.

8. Apparatus in accordance with claim 7 wherein said boxes have a length in the direction of travel of said mate-

5

rial at least twenty times the distance between said material and said plane wall portion.

9. Apparatus as set forth in claim 7 wherein said boxes on the sides towards said return ducts are cut away on the corners thereof to lead said gaseous medium downwardly away from said web-like material into said return ducts.

10. Apparatus as set forth in claim 7, in which said outlets are made in eye-lid form.

11. Apparatus as set forth in claim 7, which further includes intermediate outlets between said oppositely directed outlets for directing gaseous medium substantially perpendicularly toward said web-like material.

12. Apparatus as set forth in claim 7, which further includes opposite boxes with outlets for directing a gaseous medium against the opposite side of the web-like material.

13. Apparatus as set forth in claim 7, in which the distance, measured in the direction of travel of said material, between the medium outlets and the adjacent discharge openings is made at least ten times the distance between said material and the surface of the box.

6

14. Apparatus as set forth in claim 7, in which said outlets are formed as slots.

15. Apparatus as set forth in claim 7, in which said outlets on opposite sides of a center line, running longitudinally of the direction of travel of the web, are inclined outwardly in opposite directions to stretch said material laterally.

16. Apparatus as set forth in claim 15, in which the angle between the outlets and the center line increases progressively outwardly from the center line.

References Cited by the Examiner

UNITED STATES PATENTS

756,600	4/1904	Dodge	302—31
898,775	9/1908	Norton	302—31
2,538,972	1/1951	Magnani	302—29
2,678,237	5/1954	Allander	302—31
2,785,928	3/1957	Hanson	302—17
2,848,820	8/1958	Wallin	302—29

SAMUEL F. COLEMAN, *Primary Examiner.*

ANDRES H. NIELSEN, *Examiner.*