

1 563 368

- (21) Application No. 39277/77 (22) Filed 21 Sept. 1977
- (31) Convention Application No. 2 645 422
- (32) Filed 8 Oct. 1976 in
- (33) Fed. Rep. of Germany (DE)
- (44) Complete Specification published 26 March 1980
- (51) INT CL³ E05B 47/02
- (52) Index at acceptance E2A 106 130 136 140 401 402 428 M



(54) A MOTOR VEHICLE THEFT PROTECTION ARRANGEMENT

(71) We, DR. ING. h.c.F. PORSCHE AKTIENGESELLSCHAFT, of Porsche-strasse 42, Stuttgart-Zuffenhausen, Germany, a German Company, do hereby declare the invention, for which we pray that a patent may be granted to us, and the method by which it is to be performed, to be particularly described in and by the following statement:—

The present invention relates to a motor vehicle theft protection arrangement which includes a locking mechanism comprising a single-acting solenoid operatively connected to a locking or retention member with the solenoid being energized by way of a central actuating switch.

In Offenlegungsschrift 2 116 448, a theft protection system is proposed wherein an ignition lock is arranged at a passenger compartment of a motor vehicle with an ignition switch arranged in an engine compartment. The ignition switch is coupled with an electromagnet which is operable to effect a locking of a lock provided at the engine compartment.

One disadvantage of the proposed theft protection system resides in the fact that a thief may enter the passenger compartment of the motor vehicle relatively quickly and easily by merely opening the mechanical locks on the doors leading to the passenger compartment from which items contained therein could readily be removed.

An object of the present invention is to provide a motor vehicle theft protection arrangement which overcomes the disadvantage referred to above and functions reliably under all operating conditions.

A further object of the present invention is to provide a motor vehicle theft protection arrangement which is simple in construction and, therefore, inexpensive to manufacture.

The present invention consists in a motor vehicle having a theft protection arrangement, comprising at least one single-acting solenoid, at least one retention means for retaining at least one member of the motor vehicle in a closed position, the at least one single-acting

solenoid including an armature, a bolt for locking the at least one retention means in a predetermined position, said closing pin being operatively connected with the armature of said solenoid and the at least one retention means such that, upon an energization of the at least one solenoid, said armature displaces said bolt so as to cause said bolt to lock the at least one retention means in the predetermined position, a blocking means including a guide and a cam co-operable therewith for blocking the bolt so as to maintain the at least one retention means in the predetermined position, and a central actuating switch for controlling energization of the at least one solenoid.

In the accompanying drawings:—

Figure 1 is a schematic view of a motor vehicle having a theft protection arrangement in accordance with the present invention;

Figure 2 is an enlarged view of a portion of a central actuating switch of the theft protection arrangement taken in the direction of the arrow X in Fig. 1;

Figure 3 is an enlarged cross-sectional view taken along the line III—III of Fig. 1; and

Figure 4 is an enlarged detail view of a guide arrangement of the theft protection arrangement taken in the direction of the arrow Y in Fig. 3.

Referring now to Figure 1, a motor vehicle 1 includes a superstructure 2, wheels 3 and doors 4, 5 provided at the superstructure 2 for permitting access to an inside compartment of the motor vehicle 1. Lights 7, 8 are provided at the rear of the motor vehicle 1.

Retention or locking members 9, 10, 11, 12, 13, 14 are provided with the retention members 9, 10 forming parts of locks of the doors 4, 5, the retention members 11, 12 being provided at the bonnet and rear boot locks, and the remaining retention members 13, 14 being associated with a gear shift lever 15 and a clutch pedal 16, respectively. The retention members 13, 14 are disposed at the shift lever 15 and the clutch pedal 16 in a position where they cannot be reached without considerable difficulty from either inside the

5
10
15
20
25
30
35
40
45

50
55
60
65
70
75
80
85
90
95

passenger compartment 6 or from outside of the motor vehicle 1.

Each of the retention members functions so as to lock or secure the motor vehicle against unauthorized operation and/or unauthorized entry of the passenger compartment 6 of the motor vehicle 1. For this purpose, each retention member includes a single-acting solenoid 17 provided with a bolt 18. The solenoids 17 are each connected by electric leads or wires to a contact bridge 19 operatively connected with a central actuating switch 20.

A further contact bridge 21 is connected by a connecting element or part 22 to a rear light 7 or 8. The central actuating switch 20 is preferably mounted at a door 4 on the driver's side of the motor vehicle 1 with an additional door lock (not shown) also being provided at the door 4.

It is also possible according to the present invention to arrange the central actuating switch 20 at other positions on the motor vehicle 1, or to structurally combine the switch 20 with an available lock normally provided at the vehicle door and/or other locking component of the motor vehicle 1.

The central actuating switch 20 is provided with electrical contacts (not shown) and is connected with an ignition lock 23 in which is inserted a key 24. The ignition lock 23 is connected to a source of electrical energy such as, for example, a vehicle battery 25. Upon an insertion of the key 24, the current from the battery 25 to the central actuating switch 20 may be interrupted.

As shown in Fig. 3, each of the single-acting solenoids 17 includes a housing 26 and an axially moveable armature 27. One side of the armature 27 extends beyond the housing 26 with a compression spring 28 normally urging an abutment portion 29 of the armature 27 against a housing cover 30.

Each of the bolts 18 of the respective solenoids 17 is axially moveably guided at an opposite end of the armature 27 by a guide member or part 31 provided at the housing 26. The bolt 18 includes an abutment 32 at a side thereof facing the armature 27. A compression spring 33 is interposed between the abutment 32 and a further abutment 34 provided in the guide member 31. The compression spring 33 normally biases the bolt 18 in a direction toward the armature 27.

A blocking means 35 is arranged between the bolt 18 and a portion of the guide member 31 with the blocking means including a cam 36 and a guide groove or recess 37 provided in a portion of the bolt 18.

As shown most clearly in Figure 4, the guide groove or recess 37 is constructed in such a way that, during an axial movement of the bolt 18 from a position C to a position D, the cam 36 is moved or follows the path indicated by the arrow line 38. With a

further axial movement of the bolt 18, the cam 36 is moved or follows the path indicated by the arrow line 39 and thereby returns to the position C.

The theft protection arrangement of Figure 1 functions in the following manner. If the motor vehicle 1 is to be locked or secured, the key 24 is removed from the ignition lock 23 and all mechanical locks at the doors, bonnet, boot lid or the like are locked in a usual manner. The central actuating switch 20 is then operated or displaced from a position A into the position B (Fig. 2) by a rotation of a key (not shown) whereby all solenoids 17 of the respective retention or locking members are energized so that the respective armatures 27 are brought, for a short time period, from a position C₁ into a position D₁ (Fig. 3). By virtue of the displacement of the armatures 27, the bolts 18 are, at the same time, moved from the position C into a position D₂ and, from the position D₂, to the position D by way of the guide groove or recess 37, cam 36 and the spring force of the compression spring 33. Upon the respective bolts 18 reaching the position D, the armature 27 returns to its starting position C₁ by virtue of the spring force of the compression spring 28 acting on the abutment portion 29. By virtue of the configuration of the guide groove or recess 37 and the force of the compression spring 33, the cam 36 maintains the respective bolts 18 in the position D even though the armature 27 is retracted, whereby all of the retention members 9, 10, 11, 12, 13, 14 are locked and the motor vehicle 1 is secured against unauthorized entry.

To unlock the motor vehicle 1, the key (not shown) is re-inserted into the central actuating switch 20 which is then displaced from the position B to the position A, resulting in an energization of the respective solenoids 17, for a short period of time, whereby the armatures 27 displace the associated bolts 18 from the position D to the position D₂ with the armatures 27 returning to the position C₁ by virtue of the spring force of the compression spring 28. The bolts 18 return along the path indicated by the arrow 39 to the position C by virtue of the spring force of the compression spring 33.

If the battery 25 is flat and the motor vehicle is in a locked or secured condition, the central actuating switch 20 and solenoids 17 of the respective retention members may, as shown in Figure 1, be operated by an external source of current such as, for example, another battery 40 electrically connected to a connecting member or part 22 provided at the rear light 7 or 8. It is also possible to connect an external source of power at another member of the motor vehicle 1 with the only requirement being that such other member of the vehicle is electrically con-

nected to the central actuating switch 20.

To avoid any problems and/or inconvenience which may occur as a result of a flat battery 25 in the motor vehicle 1, it is also possible to make the interlocking of the respective retention members voltage-dependent so that if the voltage of the battery 25 falls below a predetermined level, a relay (not shown), arranged in the electric circuitry of the motor vehicle 1, is energized and operates the solenoid 17 so as to release the respective retention or locking members.

WHAT WE CLAIM IS:—

1. A motor vehicle having a theft protection arrangement, comprising at least one single-acting solenoid, at least one retention means for retaining at least one member of the motor vehicle in a closed position, the at least one single-acting solenoid including an armature, a bolt for locking the at least one retention means in a predetermined position, said closing pin being operatively connected with the armature of said solenoid, and the at least one retention means such that, upon an energization of the at least one solenoid said armature displaces said bolt so as to cause said bolt to lock the at least one retention means in the predetermined position, a blocking means including a guide and a cam co-operable therewith for blocking the bolt so as to maintain the at least one retention means in the predetermined position, and a central actuating switch for controlling energization of the at least one solenoid.

2. A vehicle according to Claim 1, wherein the central actuating switch is mounted at a door provided on a driver's side of the vehicle.

3. A vehicle according to claim 1 or 2, wherein a spring is provided for normally

biasing said bolt in a direction toward said armature, said guide and cam being arranged such that said armature displaces said bolt in an axial direction against a force of said spring so as to forcibly guide said bolt from an initial position to a position in which the retention means are locked by said bolt.

4. A vehicle according to any of claims 1 to 3, wherein the retention means are operatively connected with at least one of the conventional lock assemblies, gearshift lever and clutch pedal of the motor vehicle.

5. A vehicle according to any of claims 1 to 4, wherein means are provided for permitting operation of the central actuating switch by a source of energy external of the vehicle.

6. A vehicle according to claim 5, wherein the motor vehicle includes rear lights, and means are provided for connecting the central actuating switch with the external source of energy through one of the rear lights.

7. A vehicle according to any of claims 1 to 6, wherein the motor vehicle includes an ignition-starting lock, a battery operatively connected to the ignition-starting lock, and the central actuating switch is connected to the ignition-starting lock such that, upon an insertion of an ignition key, the supply of current to the actuating switch is interrupted.

8. A motor vehicle having a theft prevention arrangement substantially as described with reference to, and as illustrated in, the accompanying drawings.

MARKS & CLERK,
Chartered Patent Agents,
57—60 Lincolns Inn Fields,
London, WC2A 3LS,
Agents for the Applicants.

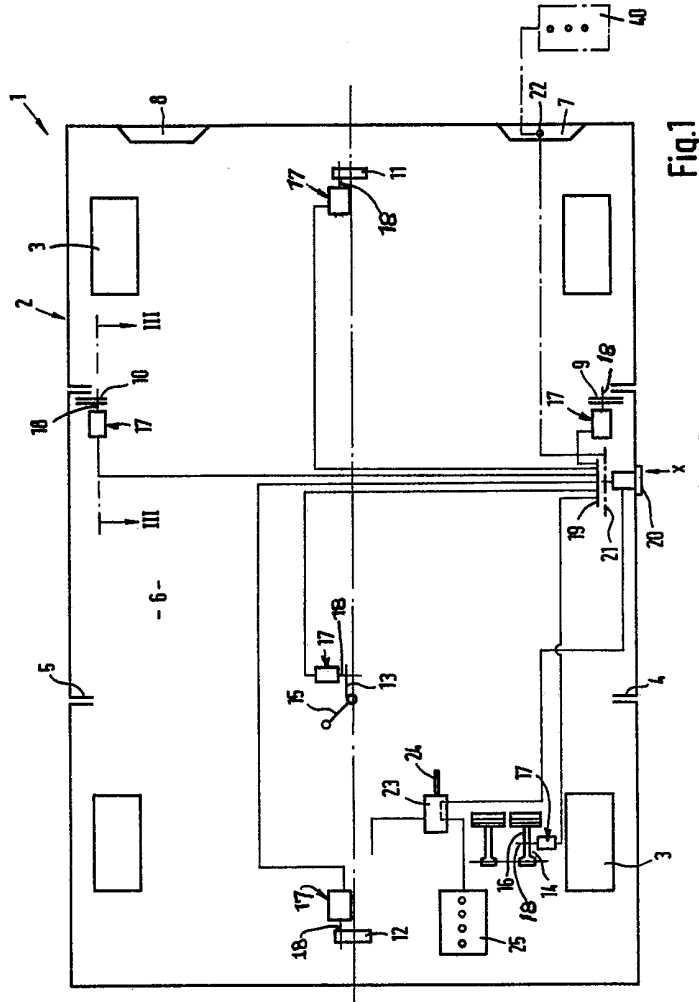

Fig. 1

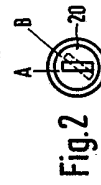

Fig. 2

- 6 -

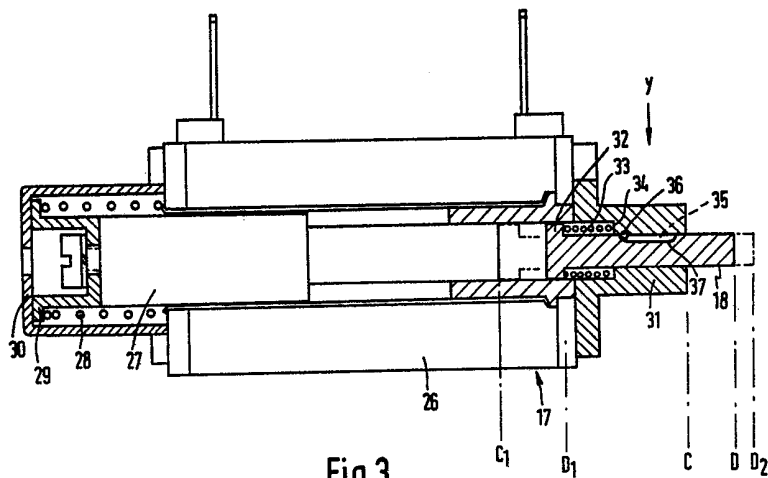

Fig.3

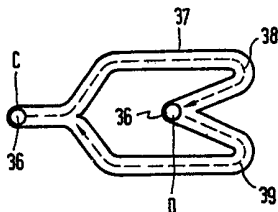

Fig.4