

(No Model.)

2 Sheets—Sheet 1.

R. A. CARTER.
ROLL MOUNTING.

No. 285,567.

Patented Sept. 25, 1883.

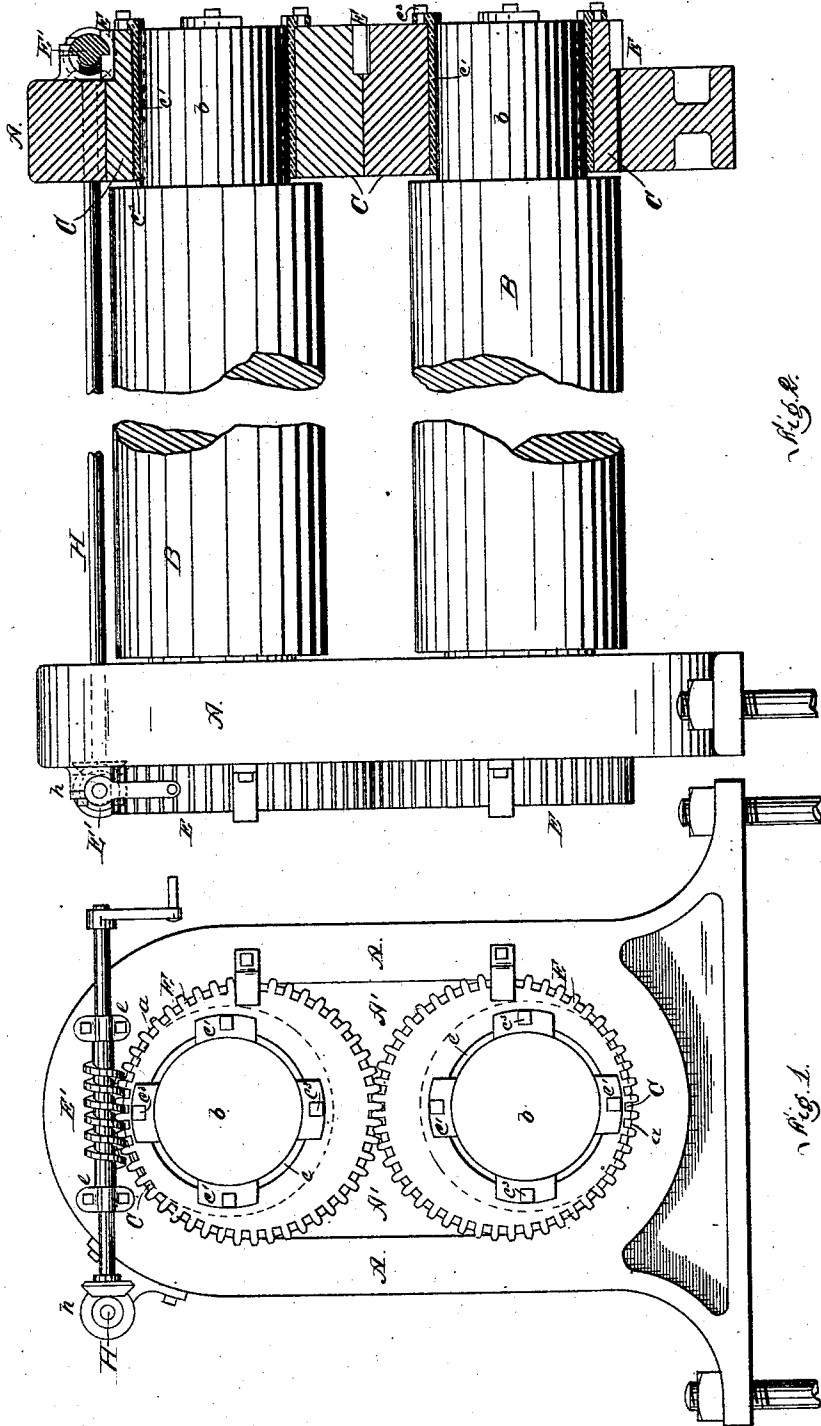

Fig. 2.

Fig. 1.

Witnessed
C. L. Parker
R. H. Whitteley

Inventor *Robert A. Carter*
By *Attorney* *George H. Christy*

R. A. CARTER.
ROLL MOUNTING.

No. 285,567.

Patented Sept. 25, 1883

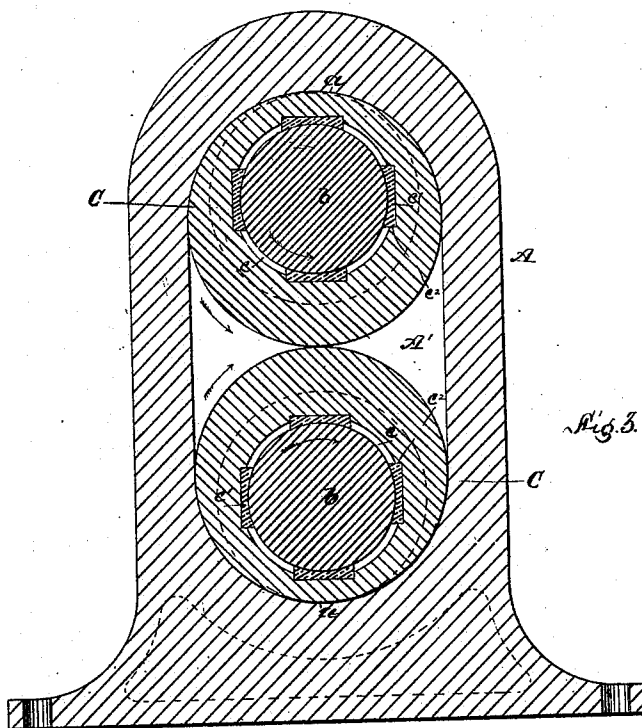

Fig. 3.

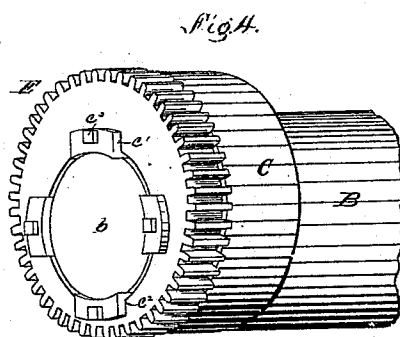

Fig. 4.

Invented Robert A. Carter.
By Attorney George H. C.

UNITED STATES PATENT OFFICE.

ROBERT A. CARTER, OF PITTSBURG, PENNSYLVANIA.

ROLL-MOUNTING.

SPECIFICATION forming part of Letters Patent No. 285,567, dated September 25, 1883.

Application filed April 19, 1883. (No model.)

To all whom it may concern:

Be it known that I, ROBERT A. CARTER, a citizen of the United States, residing at Pittsburg, in the county of Allegheny, State of Pennsylvania, have invented or discovered a new and useful Improvement in Roll-Mountings; and I do hereby declare the following to be a full, clear, concise, and exact description thereof, reference being had to the accompanying drawings, making a part of this specification, in which—like letters indicating like parts—

Figure 1, Sheet 1, is a view in end elevation of my improved roll-mounting. Fig. 2 is a view of the same in side elevation, partly in section. Fig. 3, Sheet 2, is a vertical sectional view taken in the plane of one of the housings; and Fig. 4 is a perspective view of a portion of a roll and its journal-bearing.

My invention relates to certain improvements in mechanism for mounting and adjusting rolls; and in general terms it consists of certain combinations of housings having openings with rounded ends, forming seats for cylindrical journal-boxes, such boxes having journal-openings therein out of their centers, and gear mechanism for moving and holding the journal-boxes, whereby the rolls may be adjusted toward and from each other, and other advantages secured, as hereinafter more fully described and claimed.

In the drawings, A A represent a pair of roll-housings for mounting rolls B B. In the housings are made vertical slot-openings A' A', having half-round ends *a*, (see Fig. 3,) upon which are seated cylindrical journal-boxes C. The length of the slot-openings is equal to the sum of the diameters of the journal-boxes, so that the boxes have bearing both upon the slot ends and also upon each other, giving them firm support and providing for their rotation with uniformity and steadiness of movement.

Openings or bearings *c* for the roll-journals *b* are made in the boxes C, out of or a little to one side of their centers, with the usual or any suitable form of brasses, *c'*, or equivalent bearing-strips secured by grooves *c''* and screws *c'''*. These boxes C are in effect eccentrics having fixed periphery-bearings, whereby rotation of the boxes will give the eccentric jour-

nal-bearings movement in the arc of a circle. If these eccentric bearings or boxes are rotated in opposite directions, the rolls will be made to approach or separate from each other.

As illustrated in the drawings, the rolls are at their limit of separation, so that rotation in either direction will cause them to approach. In order to effect such rotation of the eccentrics and to provide for holding the rolls at any desired position of adjustment secured by such rotation, I make use of gears E E, cast on or secured to the ends of the boxes concentric therewith, which gears intermesh and are driven with slow but powerful movement by means of worm-wheel E', journaled in suitable bearings on the face of the housings, as at *e*. Rotation of the worm-gear by power or by hand will cause rotation of both eccentrics C. On the other hand, resistance to rotary force applied from the eccentrics or gears E will be so great that the worms will form, practically, a lock, holding the rolls in any desired position of adjustment. The principal disturbing force is a tendency to separate the rolls by pressure of the article being rolled. This tendency may be reduced materially by causing the rolls to rotate for work in the same direction as the eccentrics are turned for adjusting the rolls toward each other—say as indicated by the arrows *r s*, Fig. 3—thereby causing the rotary force due to journal-friction to be operative through the eccentrics in holding the rolls against separation by working-pressure. This action is more apparent and effective at intermediate positions of adjustment, in which the roll centers are out of the vertical plane through the centers of the journal-boxes. In these positions the weight of the rolls has also a tendency to move the eccentrics, carrying both rolls downward by turning the eccentrics in the same direction. This tendency is counteracted, however, by the gearing, which will not permit the eccentrics to rotate in the same but, rather, in opposite directions. Consequently, the weight of one roll acting through its eccentrics will be counterbalanced by the other roll acting through its eccentrics. This provision or feature of roll-balance greatly facilitates movement for adjustment, affording substantially the same advantages in this respect as secured heretofore by lever-and-

weight balance for the upper movable roll. So far as I am aware it is new with me to accomplish this desirable feature by balancing the rolls one with the other, supporting them, as it were, upon the opposite ends of a lever-balance, which in the present instance is formed by the eccentrics and gearing.

I have illustrated my invention applied to two rolls; but it may be applied in substantially the same manner to more than two—say to three rolls, constituting a three-high mill—by mounting the upper and lower roll in eccentric boxes, such as described, and connecting them by gearing, whereby rotary movement of the eccentrics will cause the upper and lower rolls to approach or recede both from each other and from the intermediate roll. The rolls are mounted in both housings in similar manner, and in order to move the eccentrics at both ends simultaneously the worms E' (see Figs. 1 and 2) are connected by shaft H and bevel-gears *h h*, so that power applied to one worm-shaft will be communicated to the other.

As rolls are ordinarily mounted, the lower roll is fixed and the upper movable for adjustment; also, in close adjustment, as in sheet or plate rolls, the upper roll rides upon the lower when not separated therefrom by the article being rolled. In such mountings the upper roll falls upon the face of the lower roll upon delivery of the article, and soon produces a kind of granulation or imperfection technically known as "spalling," requiring frequent turning or refitting with considerable expense. With my improved roll-mountings this difficulty is wholly obviated, for, as before stated, the journal-boxes C bear upon each other, (see Fig. 3,) even in the closest positions of adjustment, so that these boxes prevent actual contact of the roll-faces and take all concussion or force of reaction when the rolled article is delivered. This I consider an important feature of improvement and advantage, and will materially reduce the expense of keeping rolls in good repair; also, the unyielding support afforded the journal-boxes is an important feature in securing uniformity of work and

accuracy of adjustment, and much of the time, labor, and skill heretofore required in lining and adjusting the rolls preparatory to use will be saved by this improved mounting.

I claim herein as my invention—

1. The combination of rolls B, housings A, cylindrical journal-boxes C, having journal-bearings eccentrically located therein, and gear mechanism connecting the boxes, substantially as set forth, whereby provision is made for adjusting the rolls toward and from each other, and for counterbalancing the weight of one by the other.

2. The combination of rolls B, housings A, having slots A' therein, and cylindrical journal-boxes C, having journal-bearings eccentrically located therein, such boxes also bearing one against the other within the housing-slots, substantially as set forth, whereby contact of the rolls is prevented on delivery of the rolled article.

3. The combination of two or more metal-reducing rolls B, two housings A, having slot-openings therein, with rounded ends or seats *a*, and cylindrical journal-boxes C, having bearings eccentrically located therein, such boxes being seated upon the rounded ends of the housing-slots, substantially as set forth.

4. The combination of rolls B, housings A, having openings A' therein, cylindrical journal-boxes C, having roll-bearings eccentrically located therein, the length of openings A' being equal to the sum of the diameters of the journal-boxes, and gear mechanism for rotating the journal-boxes simultaneously in opposite directions, substantially as set forth.

5. The combination of rolls B, housings A, cylindrical journal-boxes C, having roll-bearings eccentrically located therein, gears E, connecting the journal-boxes, and worms E', substantially as set forth.

In testimony whereof I have hereunto set my hand.

ROBERT A. CARTER.

Witnesses:

R. H. WHITTLESEY,
C. L. PARKER.