

(19) World Intellectual Property
Organization
International Bureau



(43) International Publication Date
1 July 2004 (01.07.2004)

PCT

(10) International Publication Number
WO 2004/055375 A1

- (51) International Patent Classification⁷: **F04D 19/04**
- (21) International Application Number:
PCT/GB2003/005370
- (22) International Filing Date: 9 December 2003 (09.12.2003)
- (25) Filing Language: English
- (26) Publication Language: English
- (30) Priority Data:
0229355.3 17 December 2002 (17.12.2002) GB
- (71) Applicant (for all designated States except US): **THE BOC GROUP PLC** [GB/GB]; Chertsey Road, Windlesham, Surrey GU20 6HJ (GB).
- (72) Inventor; and
- (75) Inventor/Applicant (for US only): **SCHOFIELD, Nigel, Paul** [GB/GB]; Milton House, 14 Rushams Road, Horsham, West Sussex RH12 2NT (GB).
- (74) Agent: **BOOTH, Andrew, Steven**; The Boc Group Plc, Chertsey Road, Windlesham, Surrey GU20 6HJ (GB).
- (81) Designated States (national): AE, AG, AL, AM, AT, AU, AZ, BA, BB, BG, BR, BW, BY, BZ, CA, CH, CN, CO, CR, CU, CZ, DE, DK, DM, DZ, EC, EE, EG, ES, FI, GB, GD, GE, GH, GM, HR, HU, ID, IL, IN, IS, JP, KE, KG, KP, KR, KZ, LC, LK, LR, LS, LT, LU, LV, MA, MD, MG, MK, MN, MW, MX, MZ, NI, NO, NZ, OM, PG, PH, PL, PT, RO, RU, SC, SD, SE, SG, SK, SL, SY, TJ, TM, TN, TR, TT, TZ, UA, UG, US, UZ, VC, VN, YU, ZA, ZM, ZW.
- (84) Designated States (regional): ARIPO patent (BW, GH, GM, KE, LS, MW, MZ, SD, SL, SZ, TZ, UG, ZM, ZW), Eurasian patent (AM, AZ, BY, KG, KZ, MD, RU, TJ, TM), European patent (AT, BE, BG, CH, CY, CZ, DE, DK, EE, ES, FI, FR, GB, GR, HU, IE, IT, LU, MC, NL, PT, RO, SE, SI, SK, TR), OAPI patent (BF, BJ, CF, CG, CI, CM, GA, GN, GQ, GW, ML, MR, NE, SN, TD, TG).
- Published:**
- with international search report
 - before the expiration of the time limit for amending the claims and to be republished in the event of receipt of amendments
- For two-letter codes and other abbreviations, refer to the "Guidance Notes on Codes and Abbreviations" appearing at the beginning of each regular issue of the PCT Gazette.*

(54) Title: VACUUM PUMPING ARRANGEMENT

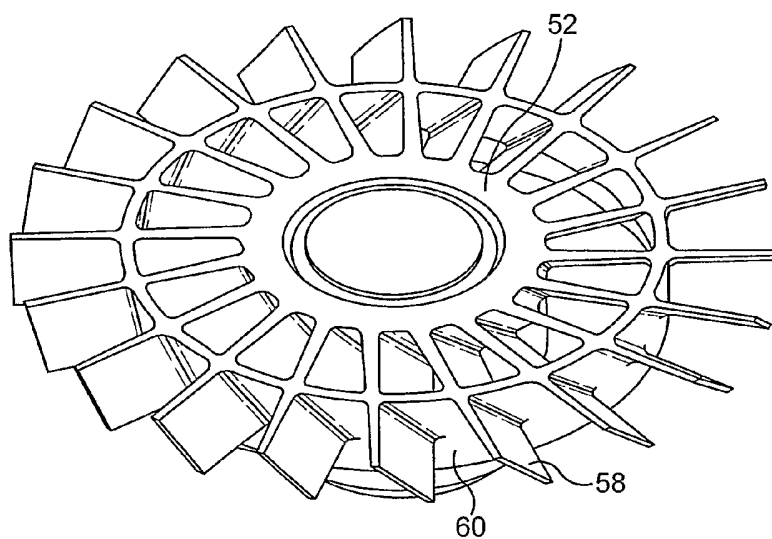

(57) Abstract: A vacuum pumping arrangement comprises a turbomolecular pumping mechanism and a molecular drag pumping mechanism connected in series. A rotor of the molecular drag pumping mechanism is supported by the rotor blades of the turbomolecular pumping mechanism.

WO 2004/055375 A1

VACUUM PUMPING ARRANGEMENT

The present invention relates to a vacuum pumping arrangement comprising a turbomolecular pumping mechanism and a molecular drag pumping mechanism connected in series.

A known vacuum pumping arrangement comprises a turbomolecular pumping mechanism connected in series with a molecular drag pumping mechanism, the latter of which can be of any suitable type such as a Holweck or a Gaede type pumping mechanism. A backing pump is generally provided to reduce pressure at the exhaust of the arrangement and may be of any suitable type such as a regenerative pump or claw pump.

The turbomolecular pumping mechanism comprises one or more circumferential arrays of angled blades supported at a generally cylindrical rotor body. During normal operation, the rotor, which is coupled to a drive shaft, is rotated between 20,000 and 200,000 revolutions per minute, during which time the rotor blades collide with molecules in a gas urging them towards the pump outlet. The molecular drag pumping mechanism comprises a rotor, which may comprise a hollow cylinder in a Holweck type pumping mechanism, coupled to the drive shaft for simultaneous rotation with the turbomolecular pumping mechanism. Rotation of the molecular drag pumping mechanism imparts a velocity to gas molecules entering it from the exhaust of the turbomolecular pumping mechanism tangentially to the

circumference of the cylinder and along spiral channels formed between a stator and the cylinder towards the drag outlet.

The cylinder of a Holweck type pumping mechanism extends generally axially with a circumference about the axis of the drive shaft, and is supported by an apertured plate extending radially from the drive shaft
5 between the turbomolecular pumping mechanism and the cylinder. Therefore, in use, gas passes from the outlet of the turbomolecular pumping mechanism, through the apertured plate and into the molecular drag pumping mechanism.

It is desirable to provide an improved vacuum pumping arrangement.

10 The present invention provides a pumping arrangement comprising a turbomolecular pumping mechanism and a molecular drag pumping mechanism connected in series, a rotor of the molecular drag pumping mechanism being supported by the rotor blades of the turbomolecular
pumping mechanism.

15 Other aspects of the present invention are defined in the accompanying claims.

In order that the present invention may be well understood, two embodiments thereof, which are given by way of example only, will now be described with reference to the accompanying drawings, in which:

20 Figure 1 is a cross-sectional view of a vacuum pumping arrangement shown schematically;

Figure 2 is a perspective view from above and one side of a rotor of a turbomolecular pumping mechanism;

Figure 3 is a perspective view from below and one side of the rotor in Figure 2;

Figure 4 is an elevation of the rotor in Figure 2;

Figure 5 is a plan of the rotor in Figure 2; and

5 Figure 6 is a cross-sectional view of another vacuum pumping arrangement shown schematically.

Referring to Figure 1, vacuum pumping arrangement 10 is shown, which comprises a molecular pumping mechanism 12 and a backing pumping mechanism 14. The molecular pumping mechanism 12 comprises a 10 turbomolecular pumping mechanism 16 and a molecular drag, or friction, pumping mechanism 18 connected in series. The backing pumping mechanism 14 comprises a regenerative pumping mechanism, which as shown is provided and driven on the same drive shaft as the molecular pumping mechanism. Alternatively, a backing pump may be provided as a 15 separate unit from the molecular pumping mechanism. A further molecular drag pumping mechanism 20 may be provided between molecular drag pumping mechanism 18 and regenerative pumping mechanism 14. Molecular drag pumping mechanism 20 comprises three drag pumping stages in series, whereas molecular drag pumping mechanism 18 comprises two drag pumping 20 stages in parallel.

Vacuum pumping arrangement 10 comprises a housing in three separate parts 22, 24, 26. Parts 22 and 24 may form the inner surfaces of the molecular pumping mechanism 12 and the molecular drag pumping

mechanism 20, as shown. Part 26 may form the stator of the regenerative pumping mechanism 14.

Part 26 defines a counter-sunk recess 28 which receives a lubricated bearing 30 for supporting a drive shaft 32. Bearing 30 may be lubricated, for instance with grease, because it is in a part of the pumping arrangement 10 distal from the inlet of the pumping arrangement. The inlet of the pumping arrangement may be in fluid connection with a semiconductor processing chamber in which a clean or oil free environment is required.

Drive shaft 32 is driven by motor 34 which as shown is supported by parts 22 and 24 of the housing. The motor may be supported at any convenient position in the vacuum pumping arrangement. Motor 34 is adapted to be able to power the regenerative pumping mechanism 14, molecular drag pumping mechanism 20 and molecular pumping mechanism 12. Generally, a regenerative pumping mechanism requires more power for operation than a molecular pumping mechanism, the regenerative pumping mechanism operating at pressures close to atmosphere where windage and air resistance is relatively high. A turbomolecular pumping mechanism, or molecular drag pumping mechanism requires relatively less power for operation, and therefore, a motor selected for powering a regenerative pump is also generally suitable for powering a turbomolecular pumping mechanism or molecular drag pumping mechanism.

Regenerative pumping mechanism 14 comprises a rotor fixed relative to drive shaft 32. As shown, the regenerative pumping mechanism 14

comprises three pumping stages, and for each stage, a circumferential array of rotor blades 38 extends substantially orthogonally from one surface of the rotor body 36. The rotor blades 38 of the three arrays extend axially into respective circumferential pumping channels 40 disposed concentrically in part 26 which constitutes the stator of the regenerative pumping mechanism 14. During operation, drive shaft 32 rotates rotor body 36 which causes the rotor blades 38 to travel along the pumping channels, pumping gas from inlet 42 in sequence along the radially outer pumping channel, radially middle pumping channel and radially inner pumping channel where it is exhausted from exhaust 44 at pressures close to or at atmospheric pressure.

Extending orthogonally from the rotor body 36 are two cylindrical drag cylinders 46 which together form the rotors of molecular drag pumping mechanism 20. The drag cylinders 46 are made from carbon fibre composite material which is both strong and light. The reduction in mass when using carbon fibre composite material drag cylinders produces less inertia when the molecular drag pumping mechanism is in operation. Accordingly, the speed of the molecular drag pumping mechanism is easier to control.

The molecular drag pumping mechanism 20 shown schematically is a Holweck type drag pump in which stator portions 48 define a spiral channel between the inner surface of housing part 24 and the drag cylinders 46. Three drag stages are shown, each of which provides a spiral path for gas flow between the rotor and the stator. The gas flow follows a tortuous path flowing consecutively through the drag stages in series.

The molecular pumping mechanism 12 is driven at an end of drive shaft 32 distal from the regenerative pumping mechanism 14. The drive shaft 32 may optionally be supported by back up bearing. A magnetic bearing 54 is provided between rotor body 52 and a cylindrical portion 56 fixed relative to the housing 22. A passive magnetic bearing is shown in which like poles of a magnet repel each other resisting radial movement of rotor body 52 relative to the central axis A. Other types of suitable bearings may be used as required.

A circumferential array of angled rotor blades 58 extend radially outwardly from rotor body 52. At approximately half way along the radial length of the rotor blades, an annular support ring 60 is provided, to which is fixed the drag cylinder, or rotor, 62 of molecular drag pumping mechanism 18, so that the rotor blades of the turbomolecular pumping mechanism support the rotor of the molecular drag pumping mechanism. Molecular drag pumping mechanism 18 comprises two drag stages in parallel with a single drag cylinder 62, one stage being radially inward thereof and one stage being radially outward thereof. Each of the stages comprise stator portions 64 with tapered inner walls 66 of the housing 22 forming a spiral molecular gas flow channel. An outlet 68 is provided to exhaust gas from the molecular drag pumping mechanism 18.

The use of the rotor blades of the turbomolecular pumping mechanism 16 for supporting the rotor of the molecular drag pumping mechanism 18 avoids the need to provide a separate support plate for the rotor of the molecular drag pumping mechanism as used in the prior art described above.

Therefore, the molecular pumping mechanism is less complicated and more compact than in the prior art. Also, it will be appreciated that the support plate, albeit an apertured support plate, will to some extent reduce the flow of gas between the turbomolecular pumping mechanism and the molecular drag pumping mechanism and therefore, act as an impediment to efficiency. There is no such impediment with the arrangement of Figure 1 where gas is allowed to flow freely from the turbomolecular pumping mechanism to the molecular drag pumping mechanism.

Figures 2 to 5 show the rotor of the turbomolecular pumping mechanism 16 in more detail. The rotor comprises the rotor body 52 which forms a hub for coupling to the drive shaft 32 (not shown in these Figures). Extending radially outwardly from the rotor body 52 are the plurality of angled rotor blades 58. Integrally formed with the rotor blades 58 is the annular ring 60 which is provided at a central radial portion of the rotor blades, or about half way along their length. The rotor, or cylinder, of the molecular drag pumping mechanism is fixed to the annular ring by any suitable method so that the rotor blades can support the rotor of the molecular drag pumping mechanism.

During normal operation, inlet 70 of pump arrangement 10 is connected to a chamber, the pressure of which it is desired to be reduced. Motor 34 rotates drive shaft 32 which in turn drives rotor body 36 and rotor body 52. Gas in molecular flow conditions is drawn in through inlet 70 to the turbomolecular pumping mechanism 16 where it is urged by the rotor blades

58 along both parallel drag pumping stages 18 and through outlet 68. Gas is then drawn through the three stages in series of the molecular drag pumping mechanism 20 and into the regenerative pumping mechanism through inlet 42. Gas is exhausted at atmospheric pressure or thereabouts through exhaust port 44.

There now follows a description of a further embodiment of the present invention. For brevity, the further embodiment will be discussed only in relation to the parts thereof which are different to the first embodiment and like reference numerals will be used for like parts.

Figure 6 shows a vacuum pumping arrangement 100 in which the molecular pumping mechanism 12 comprises a turbomolecular pumping mechanism 16 having two pumping stages in series. Two arrays of angled rotor blades 58 extend radially outwardly from the hub of the rotor body 52 with a stator formation 72 between the arrays. The rotor blades of the downstream or last stage of the turbomolecular pumping mechanism support the rotor of the molecular drag pumping mechanism and are provided with the annular ring 60 to which the rotor of the molecular drag pumping mechanism is fixed.

In a modification of the embodiments described above, the molecular drag pumping mechanism 18 comprises more than one drag cylinder, or rotor, 62 supported by the rotor blades 38 of the turbomolecular pumping mechanism 16. The turbo blades may therefore be provided with radially spaced annular rings to which are fixed respective drag pump rotors. With

this arrangement, for example, if there are three drag pump rotors, there can be up to six parallel drag pump stages, with two parallel pumping paths radially inwardly and radially outwardly of each rotor.

Although the present invention has been described with reference to
5 Figures 1 and 6 in which molecular pumping mechanism 12 is driven by a common shaft with regenerative pumping mechanism 14 and which together form one pumping unit, the present invention is not restricted in this way. Alternatively, the molecular pumping mechanism may form a pumping unit separate from the regenerative pumping mechanism, both of which are driven
10 by separate motors and separate drive shafts.

CLAIMS

1. A vacuum pumping arrangement comprising a turbomolecular
5 pumping mechanism and a molecular drag pumping mechanism connected in series, a rotor of the molecular drag pumping mechanism being supported by the rotor blades of the turbomolecular pumping mechanism.
2. A vacuum pumping arrangement as claimed in claim 1, wherein the
10 rotor blades are provided with an annular ring to which said rotor of the molecular drag pumping mechanism is fixed.
3. A vacuum pumping arrangement as claimed in claim 2, wherein the
15 turbomolecular pumping mechanism has a plurality of stages and the rotor blades of at least the last stage are provided with said annular ring.
4. A vacuum pumping arrangement as claimed in any one of the
20 preceding claims, wherein the rotor of the molecular drag pumping mechanism is supported approximately half way along the radial length of the rotor blades of the turbomolecular pumping mechanism.

5. A vacuum pumping arrangement as claimed in claim 1, wherein the molecular drag pumping mechanism has a plurality of rotors supported by said rotor blades of said turbomolecular pumping mechanism.
- 5 6. A vacuum pumping arrangement as claimed in claim 5, wherein the plurality of rotor blades are fixed to respective radially spaced annular rings provided with the rotor blades of the turbomolecular pumping mechanism.
7. A vacuum pumping arrangement as claimed in any one of the
10 preceding claims, wherein the or each rotor of the molecular drag pumping mechanism has associated therewith two parallel pumping paths comprising a pumping path radially inwardly of the or each rotor and a pumping path radially outwardly of the or each rotor.
- 15 8. A vacuum pumping arrangement as claimed in any one of the preceding claims, wherein the molecular drag pumping mechanism is of a holweck type.
9. A vacuum pumping arrangement as claimed in any one of the
20 preceding claims, further comprising a second molecular drag pumping mechanism the rotor of which is supported by the rotor of a regenerative pumping exhausting mechanism.

10. A vacuum pumping arrangement as claimed in any one of the preceding claims, wherein the rotor of the or each molecular drag pumping mechanism is made from carbon fibre composite material.
- 5 11. A vacuum pumping arrangement as claimed in any one of the preceding claims, wherein the rotor blades of the turbomolecular pumping mechanism are made from aluminium.
- 10 12. A vacuum pumping arrangement as claimed in claim 2, wherein the annular ring is made from aluminium.

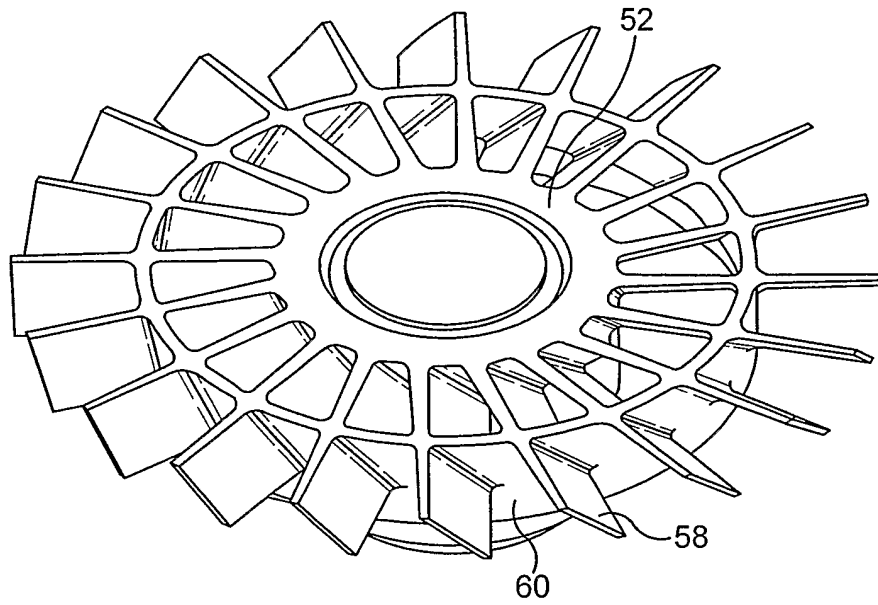

FIG. 2

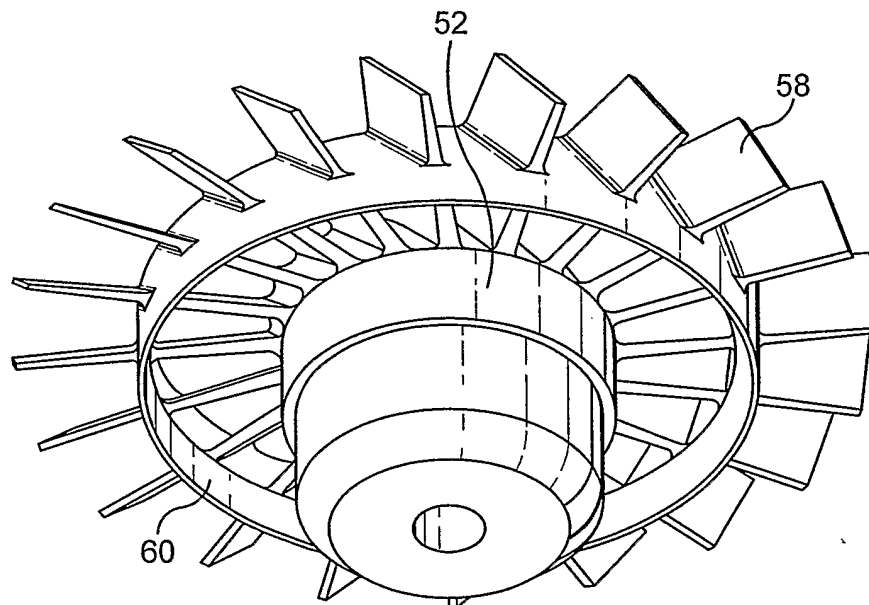

FIG. 3

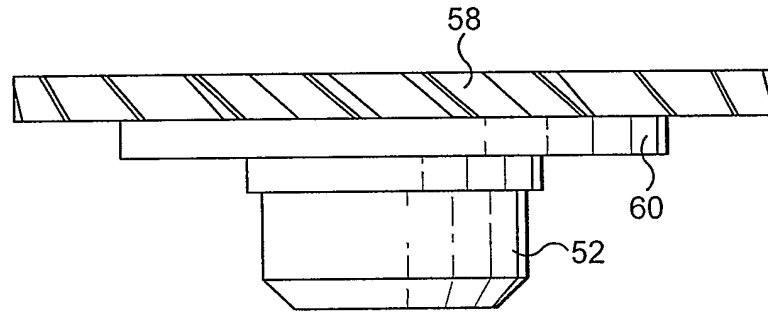

FIG. 4

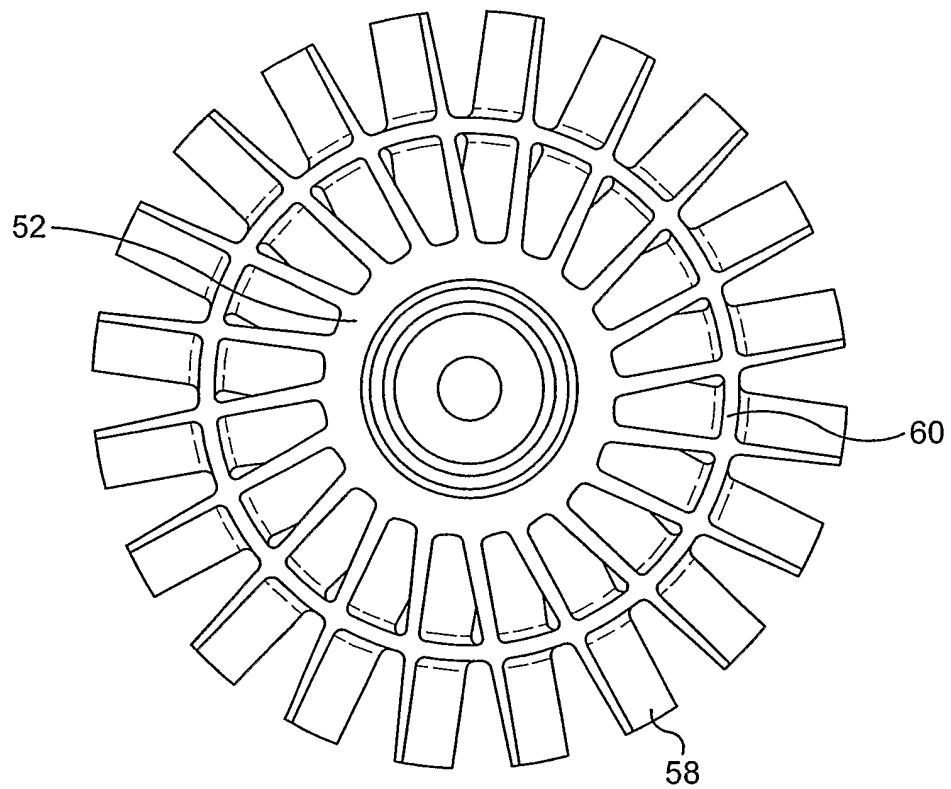

FIG. 5

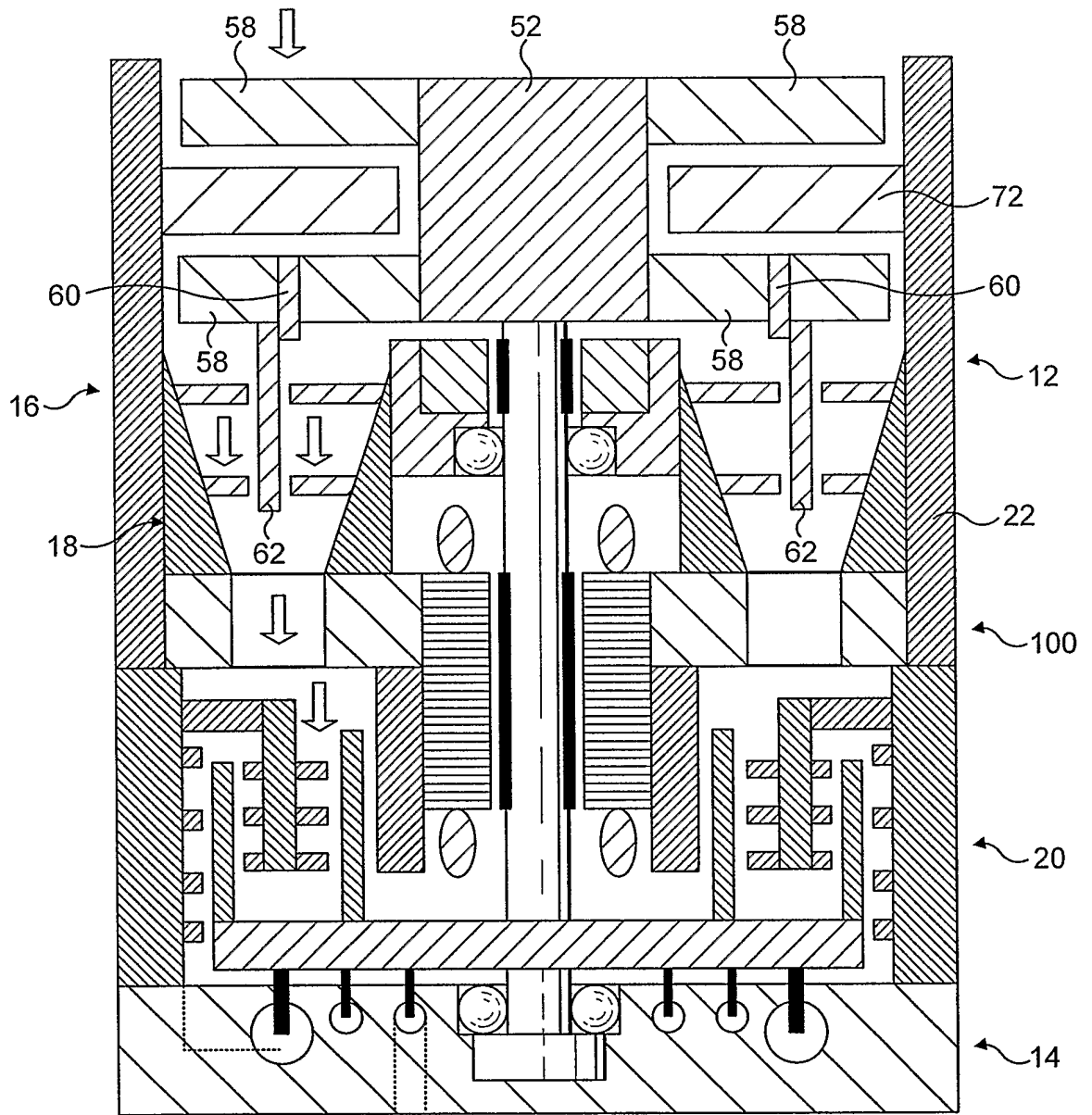

FIG. 6

INTERNATIONAL SEARCH REPORT

International Application No
PCT/GB 03/05370

A. CLASSIFICATION OF SUBJECT MATTER
IPC 7 F04D19/04

According to International Patent Classification (IPC) or to both national classification and IPC

B. FIELDS SEARCHED

Minimum documentation searched (classification system followed by classification symbols)
IPC 7 F04D

Documentation searched other than minimum documentation to the extent that such documents are included in the fields searched

Electronic data base consulted during the international search (name of data base and, where practical, search terms used)

WPI Data, PAJ, EPO-Internal

C. DOCUMENTS CONSIDERED TO BE RELEVANT

Category °	Citation of document, with indication, where appropriate, of the relevant passages	Relevant to claim No.
X	US 6 168 374 B1 (ODENDAHL HEINZ-DIETER ET AL) 2 January 2001 (2001-01-02) column 2, line 31-38 column 2, line 56-62 claim 1 figures 3-5	1-9
X	US 2002/054815 A1 (KAWASAKI HIROYUKI ET AL) 9 May 2002 (2002-05-09) paragraph '0052! figure 11	1
X	US 6 422 829 B1 (SCHUETZ GUENTER) 23 July 2002 (2002-07-23) the whole document	1-9
	-/--	

Further documents are listed in the continuation of box C.

Patent family members are listed in annex.

° Special categories of cited documents :

- *A* document defining the general state of the art which is not considered to be of particular relevance
- *E* earlier document but published on or after the international filing date
- *L* document which may throw doubts on priority claim(s) or which is cited to establish the publication date of another citation or other special reason (as specified)
- *O* document referring to an oral disclosure, use, exhibition or other means
- *P* document published prior to the international filing date but later than the priority date claimed

- *T* later document published after the international filing date or priority date and not in conflict with the application but cited to understand the principle or theory underlying the invention
- *X* document of particular relevance; the claimed invention cannot be considered novel or cannot be considered to involve an inventive step when the document is taken alone
- *Y* document of particular relevance; the claimed invention cannot be considered to involve an inventive step when the document is combined with one or more other such documents, such combination being obvious to a person skilled in the art.
- * & * document member of the same patent family

Date of the actual completion of the international search

21 April 2004

Date of mailing of the international search report

29/04/2004

Name and mailing address of the ISA

European Patent Office, P.B. 5818 Patentlaan 2
NL - 2280 HV Rijswijk
Tel. (+31-70) 340-2040, Tx. 31 651 epo nl,
Fax: (+31-70) 340-3016

Authorized officer

Giorgini, G

INTERNATIONAL SEARCH REPORT

Int'l Application No PCT/GB 03/05370

C.(Continuation) DOCUMENTS CONSIDERED TO BE RELEVANT

Category °	Citation of document, with indication, where appropriate, of the relevant passages	Relevant to claim No.
A	EP 1 101 945 A (BOC GROUP PLC) 23 May 2001 (2001-05-23) the whole document ----	1
A	EP 0 959 253 A (BOC GROUP PLC) 24 November 1999 (1999-11-24) the whole document -----	1

INTERNATIONAL SEARCH REPORT

Information on patent family members

International Application No
PCT/GB 03/05370

Patent document cited in search report	Publication date	Patent family member(s)	Publication date
US 6168374	B1	02-01-2001	DE 19632874 A1 19-02-1998
			DE 59706325 D1 21-03-2002
			WO 9807989 A1 26-02-1998
			EP 0918938 A1 02-06-1999
			JP 2000516321 T 05-12-2000
US 2002054815	A1	09-05-2002	JP 2000274394 A 03-10-2000
			EP 1039137 A2 27-09-2000
			SG 76003 A1 24-10-2000
			TW 533276 B 21-05-2003
			US 6343910 B1 05-02-2002
US 6422829	B1	23-07-2002	DE 29717079 U1 06-11-1997
			DE 59808840 D1 31-07-2003
			WO 9915793 A1 01-04-1999
			EP 1017944 A1 12-07-2000
			JP 2001517757 T 09-10-2001
EP 1101945	A	23-05-2001	EP 1101945 A2 23-05-2001
			JP 2001182685 A 06-07-2001
			US 6375413 B1 23-04-2002
EP 0959253	A	24-11-1999	EP 0959253 A2 24-11-1999
			JP 11351190 A 21-12-1999
			US 6135709 A 24-10-2000