

*J. H. Hathaway,
Rotary Steam Engine.*

N^o 26,148.

Patented Nov. 15, 1859.

Fig. 2

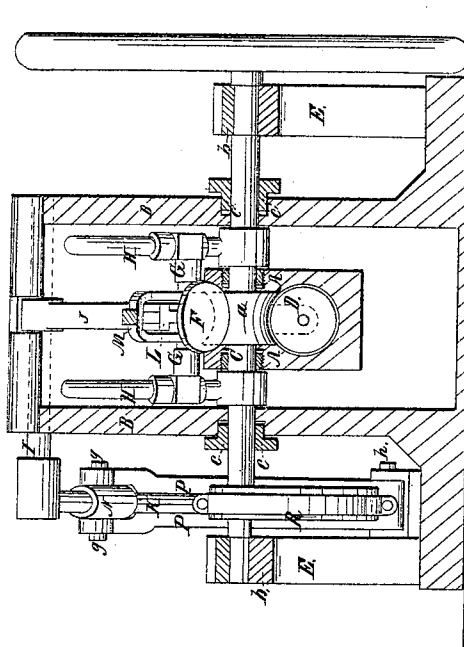
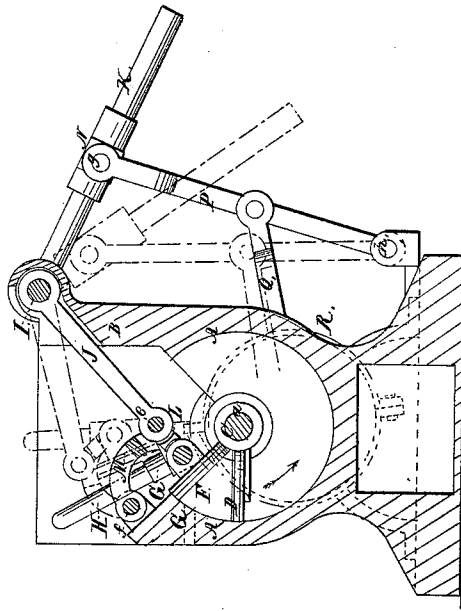

Fig. 1



Witnesses:

William Grunbaf

James H. Walp.

*Inventor
J. H. Hathaway*

UNITED STATES PATENT OFFICE.

HENRY C. RICE, OF WORCESTER, MASSACHUSETTS, ADMINISTRATOR OF JOHN H. HATHAWAY, DECEASED.

ROTARY ENGINE.

Specification of Letters Patent No. 26,148, dated November 15, 1859.

To all whom it may concern:

Be it known that JOHN H. HATHAWAY, deceased, late of Worcester, in the county of Worcester and State of Massachusetts, during his lifetime invented certain new and useful Improvements in Rotary Engines; and I, HENRY CLAY RICE, of Worcester aforesaid, administrator of the estate of said Hathaway, do hereby declare that the following is a full, clear, and exact description of the same, reference being had to the accompanying drawings, forming part of this specification, in which—

Figures 1 and 2 are vertical sections, at right angles to each other, of a rotary engine with my improvements.

Similar letters of reference indicate corresponding parts in both figures.

This invention relates to that class of rotary engine which is the subject matter of Letters Patent of the United States, granted Nov. 13, 1855, to the aforesaid John H. Hathaway. It consists in certain means of operating the movable cylinder head or abutment whereby the use of cams for that purpose is dispensed with, and the operation effected in a more positive and effective manner.

To enable others skilled in the art to make and use the invention I will proceed to describe its construction and operation.

A, is a cylinder arranged within a box B.

C, is the main shaft having firmly secured to it the hub *a*, of the circular piston D, said shaft being supported in bearings *b*, *b*, in two standards E, E, outside of the box B, and working through stuffing boxes *c*, *c*, in the box B, and stuffing boxes *d*, *d*, in the sides of the cylinder.

F, is the movable abutment or cylinder head fitted into one of the mouths of the cylinder with suitable packing to make it steam-tight, and attached rigidly to a cross head G, which is fitted to slide on two parallel arms H, H, which are radial to the shaft C, but are fitted loosely to the said shaft so that they will not interfere with or be interfered with by the rotation of the said shaft.

I, is a rock-shaft arranged parallel with the main shaft C, in bearings in the box B, and having rigidly attached to it two arms J, K. The arm J, is connected at its extremity by a joint pin *e*, with a link L, which is connected by the cross head G, and

the said arm and link combined constitute a toggle. The cross head is also connected with a forked arm M, which is arranged to vibrate on a fixed pin *f*, secured to the cylinder or the box B, said arm being curved to allow it and the abutment F, to work clear of each other. The arm K, of the rock-shaft I, is fitted with a slide N, on the sides of which are journals *g*, *g*, by which it is connected with a double lever P, P, which works on a stationary pin *h*, and which is connected with the connecting rod Q, of an eccentric R, that is fast on the main shaft C.

The steam pipe is to be connected with the cylinder at *i*, Fig. 1, just below where the stationary abutment fits in. The exhaust pipe is to be connected with the box B, which is intended to be covered so as to inclose the greater portion of the shaft I, and all the mechanism by which the abutment or cylinder head F, is connected with the said shaft and with the main shaft C.

The abutment F, has a similar operation to that described in the schedule of the before-mentioned Letters Patent of Nov. 13, 1855, that is to say it remains stationary or at least very nearly so, within the mouth of the cylinder all the time the piston is passing through the cylinder, but as the piston leaves the cylinder it (the abutment) is withdrawn from the mouth of the cylinder and then elevated to allow the piston to pass it, the latter moving in the direction of the arrow shown in Fig. 1. This operation is effected entirely by the oscillating movement of the rockshaft I, produced by the action of the eccentric R, lever P, and slide N, upon the arm K, the movement of the lever derived from the eccentric causing the slide to move back and forth along the said arm. When the abutment is in the mouth of the cylinder the toggle J L, is straight, and the rise of the arm L, produces a flexure of the toggle which first withdraws the piston F, from the cylinder and then raises it out of the path of the piston by causing the cross head G, which carries it, to slide up the arms H, H. At the time of the abutment being brought within the mouth of the cylinder by the straightening of the toggle, the lever P, P, slide N, and arm K, are in the relative positions shown in black outline in Fig. 1, and the part of the arm K, beyond the slide N, is in a position coinciding as

nearly as it can with the arc described by the extremity of the lever, so that the lever in being moved by the eccentric to carry the slide from this position toward the end of the arm K, and back again, scarcely moves the said arm or the rock-shaft I, and consequently leaves the abutment so nearly stationary that its movement is hardly perceptible and does not permit any steam to pass it; but as the slide N, is caused to approach nearer to the rock-shaft it causes a depression of the arm K, and causes the arm J, to be raised, and the toggle J L, to be bent. Now the movement of the toggle is so controlled by the connection of the cross head G, with the arm M, that as the flexure of the toggle commences it draws the abutment out of the cylinder, and then moves the cross head quickly up the arms H, H, and so lifts the abutment out of the path of the piston, the parts being then in the position represented in red outline in Fig. 1. Immediately after the piston has again entered the cylinder the slide commences to return along the arm K, and to depress it and by that means to cause a gradual

straightening of the toggle, and the return of the abutment into the cylinder.

What I claim as the invention of the aforesaid Hathaway, and desire to secure by Letters Patent, is—

1. The combination with the cross-head or its equivalent, which carries the abutment or cylinder head F, of the rock-shaft I, the toggle J L, and the vibrating arm M, the whole applied and operating substantially as herein described, in combination with the guide arms H, for the purpose specified.

2. And in combination with the above-mentioned rock-shaft I claim the arm K, slide N, lever P, and eccentric Q, applied substantially as herein described to produce an intermittent, or remittent motion of the said rock-shaft, as herein set forth.

HENRY CLAY RICE,
Administrator of the estate of J. H. Hathaway, deceased.

Witnesses:

WM. GREENLEAF,
JAMES H. WALL.