

Aug. 22, 1967

C. E. BERNING

3,337,100

MAGNETIC RAZOR KNIFE HOLDER

Filed Aug. 9, 1965

Fig. 1.

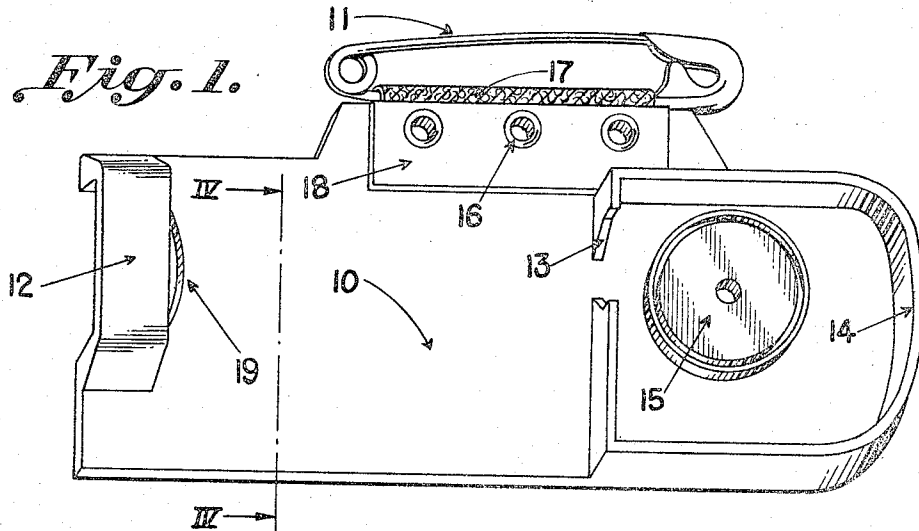

Fig. 2.

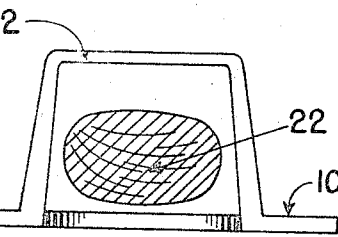
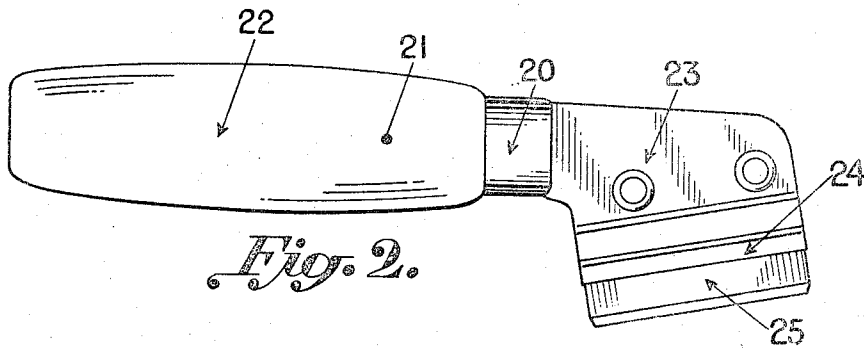

Fig. 3.

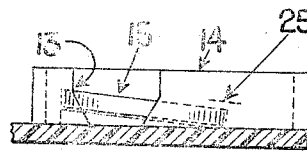

Fig. 4.

Charles E. Berning
INVENTOR.

1

3,337,100

MAGNETIC RAZOR KNIFE HOLDER

Charles E. Berning, 1118 Colton St., Toledo, Ohio 43609

Filed Aug. 9, 1965, Ser. No. 478,106

6 Claims. (Cl. 224—2)

ABSTRACT OF THE DISCLOSURE

This invention relates to an open sided magnetic sheath means for releasably holding a knife or the like instrument having a handle and a blade. The sheath may be attached by a fastener such as a safety pin at a convenient location on the clothing of the user. The holder magnetically holds the blade end of the instrument and loosely retains the free end of the handle in a socket so that the instrument may be quickly and easily removed and replaced as desired. The holder may be made of molded plastic and have a wall member for shielding the cutting edge of the instrument which wall member may also be notched to assist in correctly and easily positioning the instrument in the holder. The magnetic blade holding means may have a planar surface which is inclined so that the cutting edge of the instrument is disposed more deeply in the sheath than the non-cutting edges of the blade.

Background of invention

This present invention relates to a support and open sided protective holder for a knife or the like adapted to be carried upon the clothing of the user. It is primarily for use by tradesmen whose craft requires frequent temporary use of a knife and a readily accessible storage or carrying place for the knife while it is not in use such as may be required of paperhangers in cutting and trimming wallpaper, vinyls, and other wall fabrics. The known prior art protective knife carriers are of the scabbard type and are particularly adapted for long bladed knives which may be inserted deeply and securely into a knife scabbard and thereby retained against accidental displacement. A relatively short-bladed knife such as a paper hanger's knife, a linoleum layer's hook knife or a razor blade holding window scraper may be readily accidentally dislodged from a scabbard-type holder due to the fact that there is so little blade length available for insertion into and holding by the scabbard. Another problem with a scabbard-type knife holder is that a socket cannot be provided for constraining lateral movement of the free end of the handle without impairing the ease of withdrawal of the knife. In the normal use of such a knife, it has been difficult for a man working above floor level to find a convenient and safe surface to rest it on, when necessary to use both hands in the task being performed.

Summary of invention

Generally speaking, the protective open sided holder for a cutting instrument comprises a base or backboard member which may be affixed by a fastening means to the clothing of the user at any convenient location and which has a magnet for holding the blade end of the instrument while the other or handle end is supported against lateral displacement by a socket. The blade is recessed behind a protective wall which may be notched to engage an intermediate section of the instrument to further limit the lateral movement thereof. Accordingly, the cutting instrument may be removed readily from the face or open side of the holder by pulling outwardly on the handle and may be returned readily by inserting the handle end in the socket and placing the blade against the magnet.

2

It is therefore a primary object of the present invention to provide a holder that is capable of holding the knife without fear of snagging, cutting the user, misplacement, or dropping.

5 A further object of this invention is to provide a safety pin that supports the holder and knife in a horizontal position on a workman's garment.

Another object is the holding of the cutting instrument in a stabilized horizontal position through the medium of the magnetic flux of a magnet supported in connection with the holder.

10 Still another object of this invention is to provide a safety enclosure wall on the knife holder to protect the user against accidental cutting or snagging.

15 These and other objects will be apparent to those skilled in the art of applying wall coverings.

Brief description of the drawings

The above mentioned and other features and objects of this invention and the manner of attaining them will become more apparent and the invention itself will be understood best by reference to the following description of an embodiment of this invention taken in conjunction with the accompanying drawings, wherein:

20 FIG. 1 is a perspective view of a magnetic knife holder made in accordance with this invention.

FIG. 2 shows a perspective view of a conventional wood handle razor knife with a downturned blade.

25 FIG. 3 is a left end view of FIG. 1 showing the retaining arch for the handle of the knife of FIG. 2, which handle is shown in section.

30 FIG. 4 is a view of taken along line IV—IV of FIG. 1 showing the magnet tilted and holding the knife blade in a downward safety position for the user when in use.

Description of a preferred embodiment

Now referring to the drawings the open sided knife holder or carrier 10 may be molded of plastic and have a relatively rigid backboard or surface which has a releasable fastener 11, such as a safety pin attached along an upper edge thereof for fastening the knife holder in a horizontal or other position on a workman's garment.

35 The lower part of the pin 11 may be attached to the upper edge of the holder 10 by a folded piece of a flexible material 17 such as leather that encircles the lower part of the pin 11 and may be riveted with three eyelets 16 to the recessed portion 18 as shown on number 10. The recessed portion 18 may be formed on the under side of the holder so that the double fold of flexible material to be flush with the surrounding surface.

40 A protective wall member, or flange 14 may surround the steel blade of the razor knife 22 shown in FIGURE 2 when the knife is properly placed on the holder shown in FIG. 1. The razor knife 22 shown in FIG. 2 comprises a handle 21 which may be made of wood and have a metal collar 20 for receiving a blade assembly 23 which may have two symmetric steel plates fastened together, such as by rivets, so as to provide a retaining slot at one edge for releasably holding a replaceable cutting edge 25, such as a razor blade.

45 Behind the wall 14 a permanent magnet 15 is affixed to the base or backboard of the holder 10. The magnet 15 may be slanted so that the cutting edge 25 of the knife blade 23 may be in a downward position adjacent the backboard and wall 14 as shown in FIG. 4.

50 The surrounding safety wall 14 has a cut out opening 13 that receives the collar 20 of the knife handle and allows the steel portion 23, 24, and 25, of the knife 22, to make contact with magnet 15, FIG. 1. It also acts as a guide for handle 21.

55 An upright arch or socket 12 may be integrally attached to the backboard of the holder 10 (see FIGS. 1 and 3) to

3

guard and protect and hold the extreme end of the handle 21, from snagging on any object and being laterally displaced. It will be noted that there is a half circle cut out 19 at the base of the arch 12 on the basic flat surface 10. This cutout 19 eliminates any bind between the top side of arch 12 and the handle 21 when removing the knife.

The normal operation of the device and invention is as follows:

The razor knife as shown in FIG. 2 is taken with the right hand and the handle end is placed in alignment with the arch 12 and the handle collar 20 is placed adjacent the notch 13 and the handle 22 is then slightly pulled back. This will allow the collar 20, to drop into the opening slot 13 as the magnet 15 pulls the blade 25 into contact with itself and as the extreme end of handle 21 is placed just inside the vertical arch 12.

It is believed that a careful consideration of the description in conjunction with the view of the drawings will enable the reader to obtain a clear and comprehensive understanding of the subject matter of the invention as well as the features and advantages, mode of use, and results attained.

Numerous changes in details of construction, arrangements, and choice of materials may be effected without departing from the spirit of the invention, especially as defined in the appended claims.

What I claim is:

1. A protective open sided holder for an instrument having a handle attached to a blade with a cutting edge, at least a portion of which blade is made of magnetically attractable material, said holder comprising:

(A) a relatively rigid backboard,

(B) a wall member at one end of said backboard extending outwardly from one side of said backboard and having an opening therein for receiving said handle,

4

(C) a permanent magnet on said backboard adjacent said wall member of releasably holding said blade so that at least the cutting edge thereof is protected by said wall member,

(D) a socket at the other end of said backboard for containing the free end of said handle, and

(E) a means for releasably attaching said backboard to a support.

2. A holder according to claim 1 wherein said magnet has a substantially planar surface inclined to said side of said backboard so that the cutting edge is disposed closer to the backboard than the blade section remote from said cutting edge.

3. A holder according to claim 1 wherein said socket comprises a loop having spaced apart ends integrally attached to said backboard, and said backboard has a relief opening between said loop ends.

4. A holder according to claim 1 wherein said wall member substantially surrounds said blade except for said opening for said handle which opening confines said handle.

5. A holder according to claim 1 made out of a molded plastic material.

6. A holder according to claim 1 wherein said releasable attaching means comprises a safety-pin.

References Cited

UNITED STATES PATENTS

1,123,862	1/1915	Ellery	-----	224—2.4
1,754,526	4/1930	Rittler	-----	224—2.4
2,399,522	4/1946	Tyson	-----	224—5
2,457,032	12/1948	Case	-----	211—89
2,910,804	11/1959	White	-----	224—2
3,233,802	2/1966	Ludwick	-----	224—5

CHANCELLOR E. HARRIS, *Primary Examiner.*