



US 20050067316A1

(19) **United States**

(12) **Patent Application Publication**

Tsaur

(10) **Pub. No.: US 2005/0067316 A1**

(43) **Pub. Date: Mar. 31, 2005**

(54) **SEALED CONTAINER WITH ENCLOSED
OPENING MEANS**

Publication Classification

(51) **Int. Cl.⁷ B65D 85/30**

(52) **U.S. Cl. 206/524**

(76) **Inventor: Garry Tsaur, Rowland Heights, CA
(US)**

(57) **ABSTRACT**

Correspondence Address:
**JOE NIEH
18760 E. AMAR ROAD #204
WALNUT, CA 91789 (US)**

An elongated sealed container with a self-contained opening means fully enclosed within the container to release the liquid sealed within the container is disclosed. The enclosed opening means may be operated by either squeezing or bending the elongated sealed container at or near the enclosed opening means to release the liquid sealed within the elongated sealed container for application. There are no loose parts that may be lost and all components are completely sealed within the container.

(21) **Appl. No.: 10/670,961**

(22) **Filed: Sep. 25, 2003**

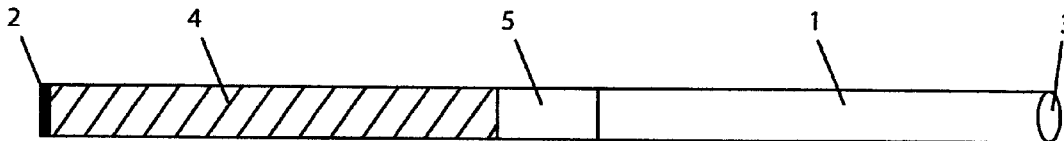

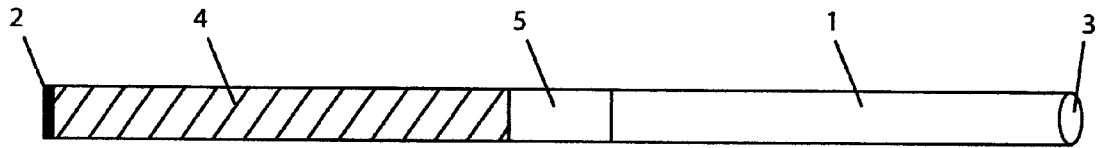

Figure 1

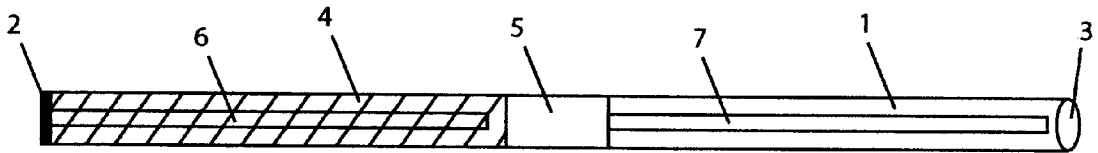

Figure 2

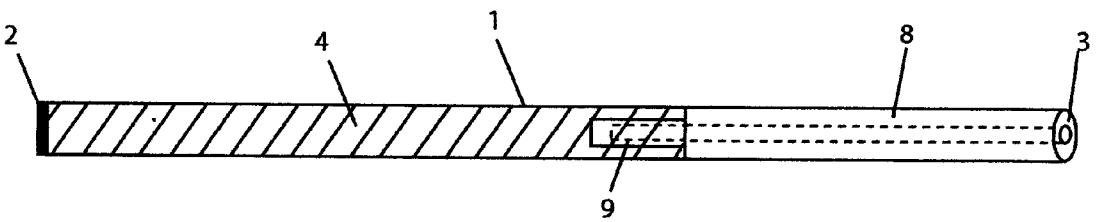

Figure 3

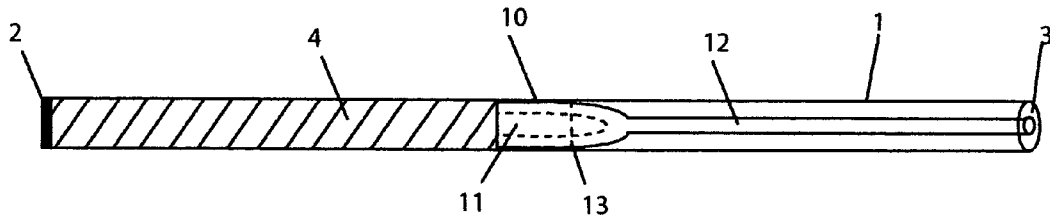

Figure 4

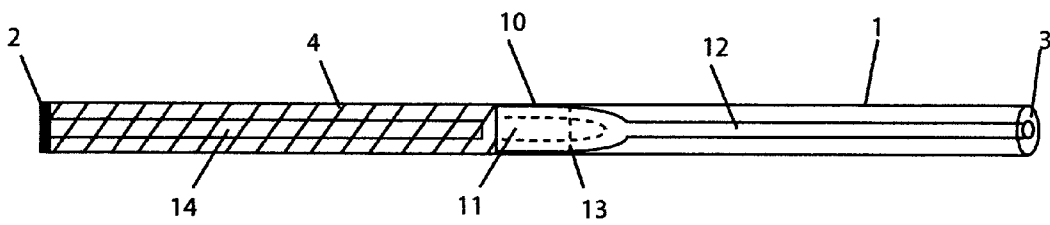

Figure 5

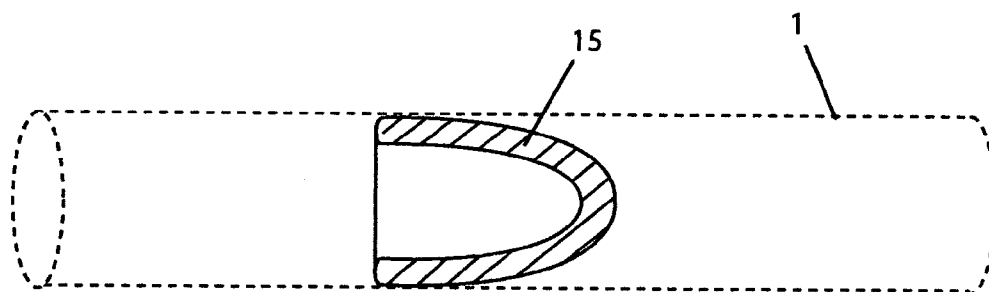

Figure 6

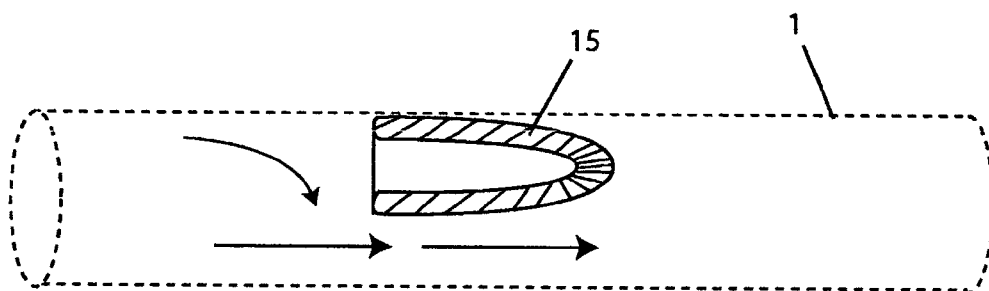

Figure 7

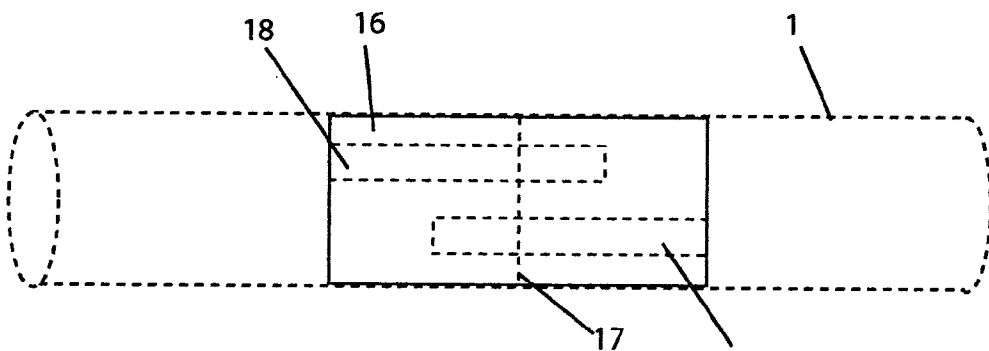

Figure 8

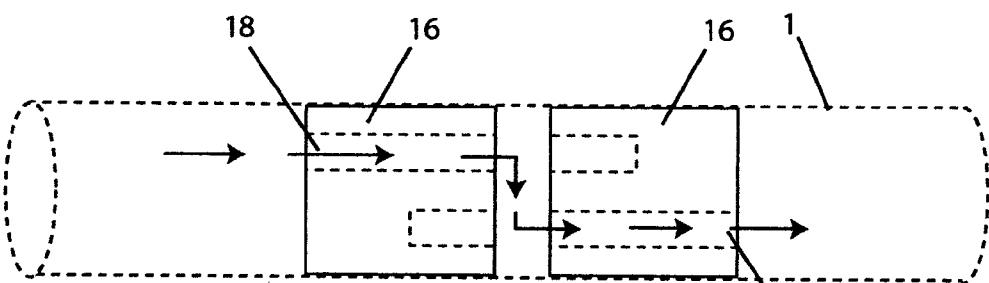

Figure 9

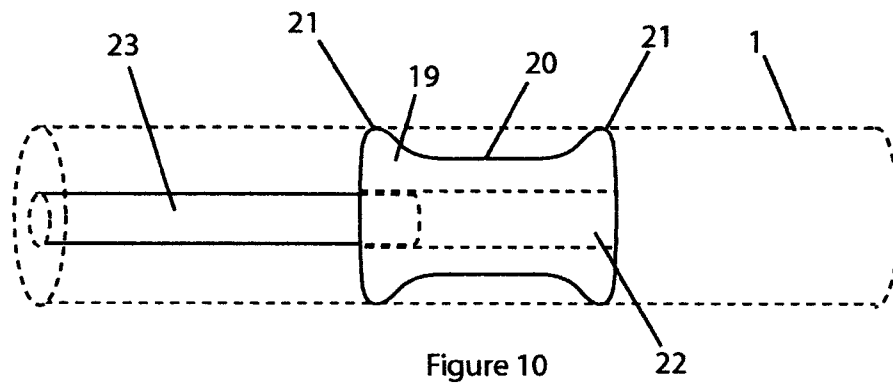

Figure 10

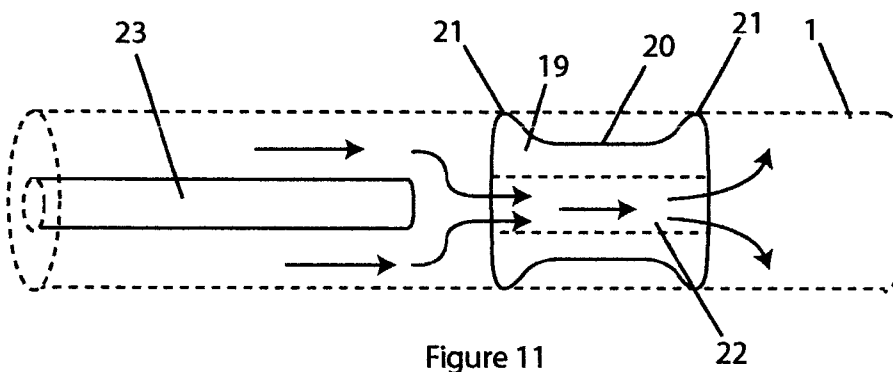

Figure 11

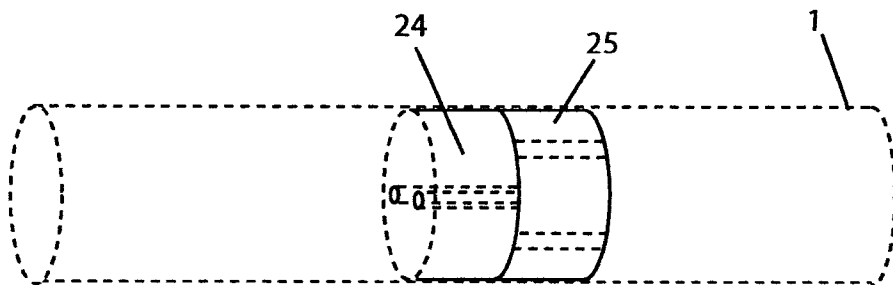

Figure 12

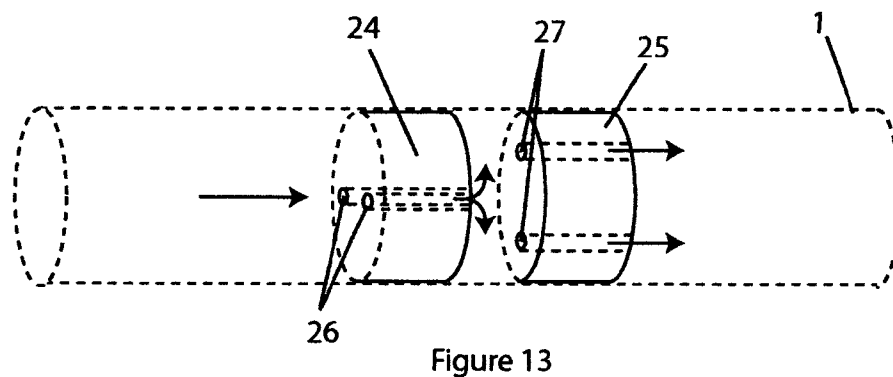

Figure 13

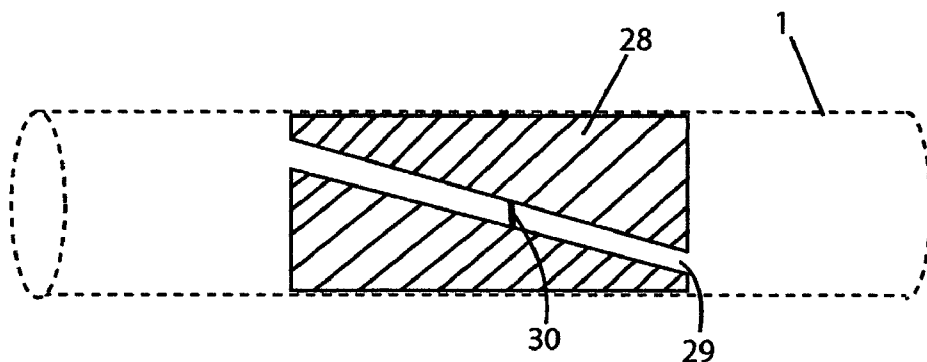

Figure 14

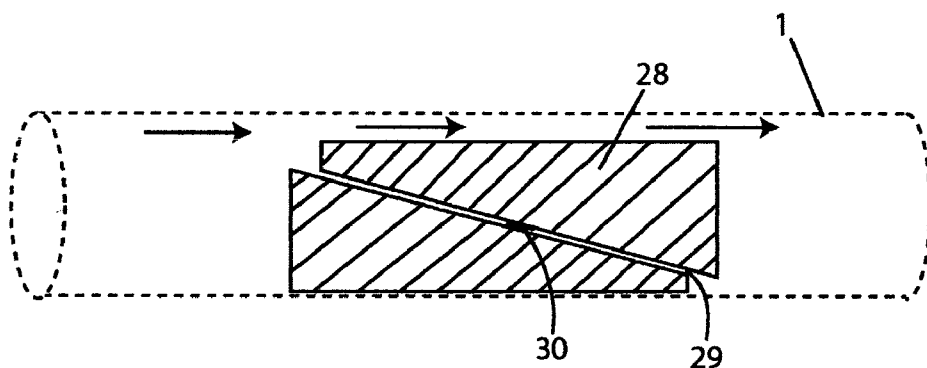

Figure 15

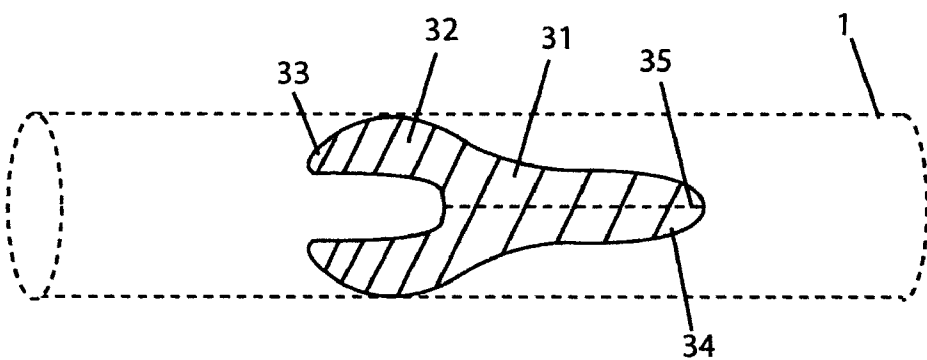

Figure 16

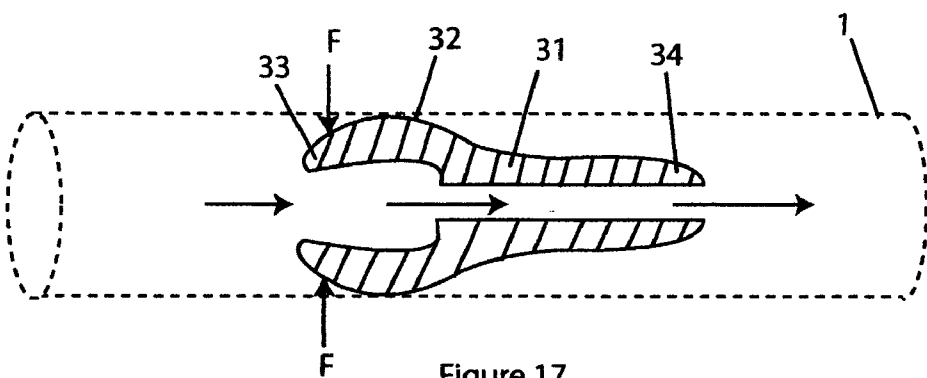

Figure 17

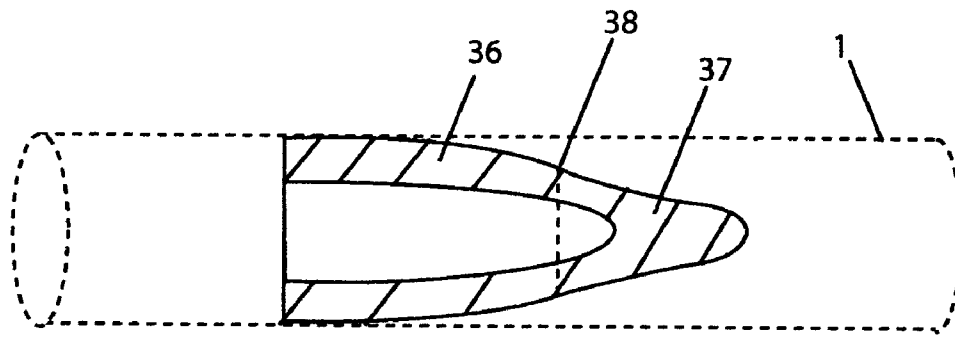

Figure 18

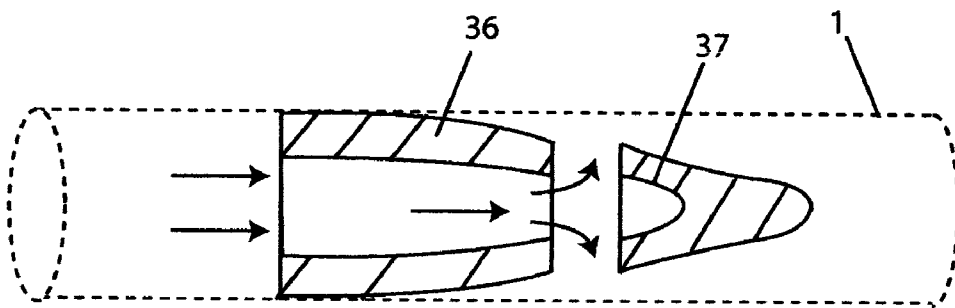

Figure 19

SEALED CONTAINER WITH ENCLOSED OPENING MEANS

BACKGROUND

[0001] 1. Field of Invention

[0002] The present invention relates generally to a sealed container with an opening means enclosed within the container for releasing the liquids enclosed within the container.

[0003] 2. Description of Related Art

[0004] A variety of opening means exists for opening a container. Most opening means are in the form of a screw-on cap or a snap-on cap. Some opening means are in the form of a frangible seal or a score line on the container that will allow the contents of the container to be released upon fracturing of the frangible seal or the container at the score line. All of these opening means are either attached to the container externally, such as the screw-on cap and the snap-on cap, or are formed as part of the container, such as the frangible seal and the score line on the container. None of the opening means are designed to be enclosed within the container to seal a liquid in the container and yet still allow the release of the liquids easily and reliably. The availability of an effective and easy to use opening means is particularly lacking for a small elongated container with a small cross-sectional area.

SUMMARY OF THE INVENTION

[0005] The present invention is an elongated sealed container with a self-contained opening means fully enclosed within the container to release the liquid sealed within the container. The enclosed opening means may be operated by either squeezing or bending the elongated sealed container at or near the enclosed opening means. Once the enclosed opening means is opened, the liquid sealed within the elongated sealed container may be released for application. When the elongated sealed container has a small cross-section such that the liquid within it cannot be released due to its surface tension, a guiding member may be utilized to increase the capillary action and to overcome the surface tension of the liquid to release the liquid from the elongated sealed container. There are no loose parts that may be lost and all components are completely sealed within the container.

BRIEF DESCRIPTION OF THE DRAWINGS

[0006] FIG. 1 shows the preferred embodiment of the sealed container with enclosed opening means.

[0007] FIG. 2 shows another embodiment of the sealed container with enclosed opening means.

[0008] FIG. 3 shows another embodiment of the sealed container with enclosed opening means.

[0009] FIG. 4 shows another embodiment of the sealed container with enclosed opening means.

[0010] FIG. 5 shows another embodiment of the sealed container with enclosed opening means.

[0011] FIG. 6 shows one embodiment of the opening means in the closed condition.

[0012] FIG. 7 shows the opening means of FIG. 6 in the open position to release the liquids in the sealed container to be released.

[0013] FIG. 8 shows one embodiment of the opening means in the closed condition.

[0014] FIG. 9 shows the opening means of FIG. 8 in the open position to release the liquids in the sealed container to be released.

[0015] FIG. 10 shows one embodiment of the opening means in the closed condition.

[0016] FIG. 11 shows the opening means of FIG. 10 in the open position to release the liquids in the sealed container to be released.

[0017] FIG. 12 shows one embodiment of the opening means in the closed condition.

[0018] FIG. 13 shows the opening means of FIG. 12 in the open position to release the liquids in the sealed container to be released.

[0019] FIG. 14 shows one embodiment of the opening means in the closed condition.

[0020] FIG. 15 shows the opening means of FIG. 14 in the open position to release the liquids in the sealed container to be released.

[0021] FIG. 16 shows one embodiment of the opening means in the closed condition.

[0022] FIG. 17 shows the opening means of FIG. 16 in the open position to release the liquids in the sealed container to be released.

[0023] FIG. 18 shows one embodiment of the opening means in the closed condition.

[0024] FIG. 19 shows the opening means of FIG. 18 in the open position to release the liquids in the sealed container to be released.

DETAILED DESCRIPTION OF THE PREFERRED EMBODIMENT

[0025] FIG. 1 shows the preferred embodiment of the sealed container with enclosed opening means. In the preferred embodiment, the sealed container with enclosed opening means comprises of an elongated tubular housing 1 with a sealed end 2 and an open end 3. A liquid 4 is enclosed within the elongated tubular housing 1 near the sealed end 2. An enclosed opening means 5 is disposed inside the elongated tubular housing 1 sealing the liquid 4 within the elongated tubular housing 1. The opening means 5 may be operated either by squeezing or bending the elongated tubular housing 1 at or near the enclosed opening means 5.

[0026] When the elongated tubular housing 1 has a small cross-section such that the liquid 4 within it cannot be released simply by opening the opening means 5 due to its surface tension, a guiding member 6, 7 may be utilized to increase the capillary action and to overcome the surface tension of the liquid 4 to release the liquid 4 from the elongated tubular housing 1 as shown in FIGS. 2, 4, and 5.

[0027] One embodiment of the enclosed opening means 5 is shown in FIG. 3 wherein the enclosed opening means 5 comprises of a cylinder 8 with an outside diameter approxi-

mately that of the inside diameter of the elongated tubular housing 1 defining a small liquid path from the open end 3 of the elongated tubular housing 1 to the liquid 4. The end near the liquid 4 has an elongated protrusion 9 that is smaller in diameter than the cylindrical body of the enclosed opening means 5 and is separable from the cylindrical body of the enclosed opening means 5. The elongated protrusion 9 seals the small liquid path in the cylinder 8 and prevents the liquid 4 in the elongated tubular housing 1 from being released through the enclosed opening means 5. When the elongated tubular housing 1 is bent near the junction between the elongated protrusion 9 and the cylindrical body of the enclosed opening means 5, the elongated protrusion 9 will be separated from the cylindrical body and the small liquid path is exposed for the liquid 4 to be released from the elongated tubular housing 1 through the opening means 5.

[0028] FIG. 4 shows another embodiment of the sealed container with enclosed opening means. In this embodiment, the sealed container with enclosed opening means comprises of an elongated bendable tubular housing 1 with a small cross-section and with a sealed end 2 and an open end 3. A liquid 4 is enclosed within the elongated tubular housing 1 near the sealed end 2. An enclosed opening means 5 is disposed inside the elongated tubular housing 1 sealing the liquid 4 within the elongated tubular housing 1.

[0029] The enclosed opening means 5 comprises of a hollow cylindrical body 10 with an open end 11 toward the liquid 4 and a sealed end with an elongated member 12 extending away from the hollow cylindrical body 10 towards the open end 3 of the elongated bendable tubular housing 1 and terminating near the open end 3 of the elongated bendable tubular housing 1. A frangible section 13, which may be formed by a score line on the outer surface of the hollow cylindrical body 10, is formed on the hollow cylindrical body 10 near the sealed end of the hollow cylindrical body 10.

[0030] When the tubular housing 1 is bent at or near the frangible section 13 of the hollow cylindrical body 10 of the opening means 5, the sealed end of the hollow cylindrical body 10 will separate from the open end 11 of the hollow cylindrical body 10 which results in a through liquid path from the liquid 4 to the open end 3 of the elongated tubular housing 1. Due to the small cross-section of the elongated bendable tubular housing 1, the liquid 4 will not flow freely out of the tubular housing 1 due to surface tension of the liquid 4. The liquid 4 may be selectively released from the tubular housing 1 by squeezing the portion of the tubular housing 1 containing the liquid 4 to force the liquid 4 toward the elongated member 12. Once the liquid 4 reaches the elongated member 12, the elongated member 12 will increase the capillary action of the liquid 4 to overcome the surface tension of the liquid 4 within the tubular housing 1 to allow it to freely flow out of the tubular housing 1.

[0031] If immediate release of the liquid 4 upon opening of the opening means 5 is desired, a second elongated member 14 may be affixed to the sealed end 2 of the tubular housing 1 and extending to near the open end 11 of the cylindrical body 10 as shown in FIG. 5 to increase the capillary action of the liquid 4 to overcome the surface tension of the liquid 4 to allow the liquid 4 to be immediately released from the tubular housing 1 upon opening of the opening means 5 without being squeezed.

[0032] FIG. 6 shows another embodiment of the enclosed opening means 5. In this embodiment, the enclosed opening means 5 comprises of a deformable cup 15 with a diameter approximately that of the inside diameter of the tubular housing 1 and a length that is longer than the diameter. The deformable cup 15 is inserted into the tubular housing 1 to seal the liquid 4 within the tubular housing 1. As shown in FIG. 7, upon bending or squeezing the tubular housing 1 at or near the opening means 5, the deformable cup 15 is deformed and a liquid flow path is exposed to allow the liquid 4 to be released from the tubular housing 1. A deformable sphere such as a plastic hollow ball with approximately that of the inside diameter of the tubular housing 1 may also be used instead of the deformable cup 15. Upon bending or squeezing the tubular housing 1 at the opening means 5, the deformable sphere will be deformed and a liquid flow path is exposed to allow the liquid 4 to be released from the tubular housing 1.

[0033] FIG. 8 shows another embodiment of the enclosed opening means 5. In this embodiment, the enclosed opening means 5 comprises of a plug 16 that is fracturable into two parts at a fracture surface 17 when it is bent. The plug 16 has one or more holes 18 extending from each end of the plug 16 pass the fracture surface 17 without passing through the other end of the plug 16. As shown in FIG. 9, upon bending of the tubular housing 1 at or near the plug 16, the plug 16 will separate into two sections at the fracture surface 17 and one or more liquid flow paths are formed leading from the liquid 4 to the open end 3 of the tubular housing 1. The plug 16 may also be fracturable or separable when it is twisted such that if the tubular housing can be twisted at the opening means 5 to open the liquid flow path. The tubular housing may be formed by two sections that are screwed together at the plug 16 such that twisting the tubular housing will separate the plug 16 into two parts.

[0034] FIG. 10 shows another embodiment of the enclosed opening means 5 wherein the enclosed opening means 5 comprises of a cylindrical section 19 with a reduced outside diameter waist section 20 and two ends 21 with outside diameters approximately that of the inside diameter of the tubular housing 1. The cylindrical section 19 has a through hole 22 in its axial direction forming a liquid flow path from the liquid 4 to the open end 3 of the tubular housing 1. An elongated member 23 is affixed to the sealed end 2 and extending into the hole 22 in the cylindrical section 19, thereby sealing the hole 22 and the liquid flow path. When the tubular housing 1 is bent at or near the cylindrical section 19, the elongated member 23 will be pulled out of the hole 22 in the cylindrical section 19 and the liquid flow path from the liquid 4 to the open end 3 of the tubular housing 1 is exposed as shown in FIG. 11. The liquid 4 may then be released from the tubular housing 1.

[0035] FIG. 12 shows another embodiment of the enclosed opening means 5 wherein the enclosed opening means 5 comprises of two circular discs 24, 25 with approximately the same cross-section as the inside diameter of the tubular housing 1 and with sufficient thickness to prevent them from flipping inside the tubular housing 1. Each circular disc 24, 25 has one or more holes 26, 27 through it positioned such that when the two circular discs 24, 25 are placed next to each other in the tubular housing 1, the holes 26, 27 in each circular disc will be covered by the other disc therefore all the holes 26, 27 in both circular discs 24, 25 are

sealed by the other circular disc. When the tubular housing 1 is bent at or near the two circular discs 24, 25, the deformation of the tubular housing 1 will cause the two circular discs 24, 25 to separate from each other and a liquid flow path will result from the liquid 4 to the open end 3 of the tubular housing 1 as shown in FIG. 13. The separation between the two circular discs 24, 25 may also be formed by twisting the tubular housing if the tubular housing can be twisted at the opening means 5 to open the liquid flow path. The tubular housing may be formed by two sections that are screwed together at the interface between the two circular discs 24, 25 such that twisting the tubular housing will separate the two circular discs 24, 25.

[0036] FIG. 14 shows another embodiment of the enclosed opening means 5 wherein the enclosed opening means 5 comprises of a cylindrical section 28 with sufficient length to prevent it from turning inside the tubular housing 1. The cylindrical section 28 has a diagonal slit 29 formed diagonally from one end to the other with a thin section of material 30 connecting the two halves of the cylindrical section 28 and sealing the liquid 4 in the tubular housing 1 behind the cylindrical section 28. When the cylindrical section 28 is compressed by squeezing the tubular housing 1, the two halves of the cylindrical section 28 will slide against each other and press together thereby reducing the cross-section of the cylindrical section 28. A liquid flow path is therefore formed between the outside of the cylindrical section 28 and the inside wall of the tubular housing 1 to allow the liquid 4 to be released from the tubular housing 1.

[0037] FIG. 16 shows another embodiment of the enclosed opening means 5 wherein the opening means 5 comprises of a section of material 31 with approximately the same diameter near its mid-section 32 as the inside diameter of the tubular housing 1. The first end 33 of the section of material 31 is formed in the form of two prongs that will act as handles wherein opposing forces can be applied by squeezing the two prongs toward each other. The second end 34 of the section of material 31 has a smaller cross-section than the inside diameter of the tubular housing 1 and a fracture surface 35 is formed from the second end 34 to near where the two prongs at the first end 33 are joined. When the two prongs are squeezed toward each other by squeezing the tubular housing 1, the section of material 31 will fracture into two halves along the fracture surface 35 along its longitudinal direction and open a liquid flow path through the section of material 31 to allow the release of the liquid 4 from the tubular housing 1 as shown in FIG. 17.

[0038] FIG. 18 shows another embodiment of the enclosed opening means 5 wherein the enclosed opening means 5 comprises of an elongated cup 36 with a diameter approximately that of the inside diameter of the tubular housing 1 and a length that is longer than the diameter. The closed end 37 of the elongated cup 36 is formed in an elongated protrusion with a fracture line 38 formed around the elongated protrusion positioned along the elongated cup 36 at a point where when the elongated protrusion is fractured, an opening will be formed at the closed end 37 of the elongated cup 36. The elongated cup 36 is inserted into the tubular housing 1 to seal the liquid 4 within the tubular housing 1. As shown in FIG. 19, upon bending the tubular housing 1 near the closed end 37 of the elongated cup 36, the elongated protrusion will fracture from the elongated cup 36

at the fracture line 38 and a liquid flow path is exposed to allow the liquid 4 to be released from the tubular housing 1.

[0039] Although the description above contains many specificities, these should not be construed as limiting the scope of the invention but as merely providing illustrations of some of the presently preferred embodiments of this invention. Thus the scope of the invention should be determined by the appended claims and their legal equivalents, rather than by the examples given.

What is claimed is:

1. A sealed container with enclosed opening means comprising an elongated tubular housing with a sealed end and an open end, a liquid enclosed within the elongated tubular housing near the sealed end, an enclosed opening means disposed inside the elongated tubular housing sealing the liquid within the elongated tubular housing wherein the opening means may be operated to release the liquid from the elongated tubular housing.

2. A sealed container with enclosed opening means as in claim 1, wherein said enclosed opening means comprises of a cylinder with an outside diameter approximately that of the inside diameter of said elongated tubular housing defining a liquid flow path from the liquid to the open end of said elongated tubular housing and an elongated protrusion that is separable from the cylinder extending from an end of the cylinder near the liquid and sealing the liquid flow path.

3. A sealed container with enclosed opening means as in claim 1, wherein said enclosed opening means comprises of a hollow cylindrical body with an open end disposed toward the liquid and a sealed end with an elongated member extending therefrom to the open end of the elongated tubular housing with a frangible section formed on the hollow cylindrical body near the sealed end of the hollow cylindrical body.

4. A sealed container with enclosed opening means as in claim 1, wherein said enclosed opening means comprises of a deformable cup.

5. A sealed container with enclosed opening means as in claim 1, wherein said enclosed opening means comprises of a deformable sphere.

6. A sealed container with enclosed opening means as in claim 1, wherein said enclosed opening means comprises of a plug that is fracturable at a fracture surface wherein said plug has one or more holes extending from each end of the plug that extend past the fracture surface without passing through the other end of the plug wherein upon bending of the tubular housing at or near the plug the plug will fracture at said fracture surface and one or more liquid flow paths are formed leading from the liquid to the open end of the tubular housing.

7. A sealed container with enclosed opening means as in claim 6, wherein said plug may also be fracturable or separable when it is twisted wherein when the tubular housing is twisted at the opening means to open the liquid flow path.

8. A sealed container with enclosed opening means as in claim 1, wherein said enclosed opening means comprises of a cylindrical section with a reduced outside diameter waist section and two ends with outside diameters approximately that of the inside diameter of the tubular housing wherein said cylindrical section defines a through hole in its axial direction forming a liquid flow path from the liquid to the open end of the tubular housing and an elongated member

affixed to the sealed end of said tubular housing and extending into the hole in the cylindrical section thereby sealing the hole and the liquid flow path wherein when the tubular housing is bent or pulled at or near the cylindrical section the elongated member will be pulled out of the hole in the cylindrical section and the liquid flow path from the liquid to the open end of the tubular housing is exposed.

9. A sealed container with enclosed opening means as in claim 1, wherein said enclosed opening means comprises of two circular discs with approximately the same cross-section as the inside diameter of the tubular housing and with sufficient thickness to prevent them from flipping inside the tubular housing wherein each circular disc has one or more holes through it positioned such that when the two circular discs are placed next to each other in the tubular housing the holes in each circular disc will be covered by the other disc thereby all the holes in both circular discs are sealed by the other circular disc and when the tubular housing is bent at or near the two circular discs the deformation of the tubular housing will cause the two circular discs to separate from each other and a liquid flow path will result.

10. A sealed container with enclosed opening means as in claim 9, wherein said separation between the two circular discs is formed by twisting the tubular housing.

11. A sealed container with enclosed opening means as in claim 1, wherein said enclosed opening means comprises of a cylindrical section with sufficient length to prevent it from turning inside the tubular housing and with a diagonal slit formed diagonally from one end to the other with a thin section of material connecting the two halves of the cylindrical section and sealing the liquid in the tubular housing behind the cylindrical section wherein when the cylindrical section is compressed by squeezing the tubular housing the two halves of the cylindrical section will slide against each other and press together thereby reducing the cross-section of the cylindrical section to form a liquid flow path between the outside of the cylindrical section and the inside wall of the tubular housing to allow the liquid to be released from the tubular housing.

12. A sealed container with enclosed opening means as in claim 1, wherein said enclosed opening means comprises of a section of material with approximately the same diameter near its mid-section as the inside diameter of the tubular housing with a first end of the section of material formed in the form of two prongs that will act as handles wherein opposing forces can be applied by squeezing the two prongs toward each other and a second end of the section of material with a smaller cross-section than the inside diameter of the tubular housing and a fracture surface formed from the second end to near where the two prongs at the first end are joined whereby when the two prongs are squeezed toward each other by squeezing the tubular housing, the section of material will fracture into two halves along the fracture surface along its longitudinal direction and open a liquid flow path through the section of material to allow the release of the liquid from the tubular housing.

13. A sealed container with enclosed opening means as in claim 1, wherein said enclosed opening means comprises of an elongated cup with a diameter approximately that of the inside diameter of the tubular housing and a length that is longer than the diameter with a closed end terminate in an elongated protrusion with a fracture line formed around the elongated protrusion positioned along the elongated cup at a point where when the elongated protrusion is fractured an

opening will be formed at the closed end of the elongated cup whereby said elongated cup is inserted into the tubular housing to seal the liquid within the tubular housing wherein upon bending the tubular housing near the closed end of the elongated cup the elongated protrusion will fracture from the elongated cup at the fracture line and a liquid flow path is exposed to allow the liquid to be released from the tubular housing.

14. A sealed container with enclosed opening means comprising an elongated tubular housing with a sealed end and an open end, an elongated member affixed to said sealed end, a liquid enclosed within the elongated tubular housing near the sealed end, an enclosed opening means disposed inside the elongated tubular housing sealing the liquid within the elongated tubular housing wherein the opening means may be operated to release the liquid from the elongated tubular housing.

15. A sealed container with enclosed opening means as in claim 14, wherein said enclosed opening means comprises of a cylinder with an outside diameter approximately that of the inside diameter of said elongated tubular housing defining a liquid flow path from the liquid to the open end of said elongated tubular housing and an elongated protrusion that is separable from the cylinder extending from an end of the cylinder near the liquid and sealing the liquid flow path.

16. A sealed container with enclosed opening means as in claim 14, wherein said enclosed opening means comprises of a hollow cylindrical body with an open end disposed toward the liquid and a sealed end with an elongated member extending therefrom to the open end of the elongated tubular housing with a frangible section formed on the hollow cylindrical body near the sealed end of the hollow cylindrical body.

17. A sealed container with enclosed opening means as in claim 14, wherein said enclosed opening means comprises of a deformable cup.

18. A sealed container with enclosed opening means as in claim 14, wherein said enclosed opening means comprises of a deformable sphere.

19. A sealed container with enclosed opening means as in claim 14, wherein said enclosed opening means comprises of a plug that is fracturable at a fracture surface wherein said plug has one or more holes extending from each end of the plug that extend pass the fracture surface without passing through the other end of the plug wherein upon bending of the tubular housing at or near the plug the plug will fracture at said fracture surface and one or more liquid flow paths are formed leading from the liquid to the open end of the tubular housing.

20. A sealed container with enclosed opening means as in claim 19, wherein said plug may also be fracturable or separable when it is twisted wherein when the tubular housing is twisted at the opening means to open the liquid flow path.

21. A sealed container with enclosed opening means as in claim 14, wherein said enclosed opening means comprises of a cylindrical section with a reduced outside diameter waist section and two ends with outside diameters approximately that of the inside diameter of the tubular housing wherein said cylindrical section defines a through hole in its axial direction forming a liquid flow path from the liquid to the open end of the tubular housing and an elongated member affixed to the sealed end of said tubular housing and extending into the hole in the cylindrical section thereby

sealing the hole and the liquid flow path wherein when the tubular housing is bent or pulled at or near the cylindrical section the elongated member will be pulled out of the hole in the cylindrical section and the liquid flow path from the liquid to the open end of the tubular housing is exposed.

22. A sealed container with enclosed opening means as in claim 14, wherein said enclosed opening means comprises of two circular discs with approximately the same cross-section as the inside diameter of the tubular housing and with sufficient thickness to prevent them from flipping inside the tubular housing wherein each circular disc has one or more holes through it positioned such that when the two circular discs are placed next to each other in the tubular housing the holes in each circular disc will be covered by the other disc thereby all the holes in both circular discs are sealed by the other circular disc and when the tubular housing is bent at or near the two circular discs the deformation of the tubular housing will cause the two circular discs to separate from each other and a liquid flow path will result.

23. A sealed container with enclosed opening means as in claim 22, wherein said separation between the two circular discs is formed by twisting the tubular housing.

24. A sealed container with enclosed opening means as in claim 14, wherein said enclosed opening means comprises of a cylindrical section with sufficient length to prevent it from turning inside the tubular housing and with a diagonal slit formed diagonally from one end to the other with a thin section of material connecting the two halves of the cylindrical section and sealing the liquid in the tubular housing behind the cylindrical section wherein when the cylindrical section is compressed by squeezing the tubular housing the two halves of the cylindrical section will slide against each other and press together thereby reducing the cross-section of the cylindrical section to form a liquid flow path between the outside of the cylindrical section and the inside wall of the tubular housing to allow the liquid to be released from the tubular housing.

25. A sealed container with enclosed opening means as in claim 14, wherein said enclosed opening means comprises of a section of material with approximately the same diameter near its mid-section as the inside diameter of the tubular housing with a first end of the section of material formed in the form of two prongs that will act as handles wherein opposing forces can be applied by squeezing the two prongs toward each other and a second end of the section of material with a smaller cross-section than the inside diameter of the tubular housing and a fracture surface formed from the second end to near where the two prongs at the first end are joined whereby when the two prongs are squeezed toward each other by squeezing the tubular housing, the section of material will fracture into two halves along the fracture surface along its longitudinal direction and open a liquid flow path through the section of material to allow the release of the liquid from the tubular housing.

26. A sealed container with enclosed opening means as in claim 14, wherein said enclosed opening means comprises of an elongated cup with a diameter approximately that of the inside diameter of the tubular housing and a length that is longer than the diameter with a closed end terminate in an elongated protrusion with a fracture line formed around the elongated protrusion positioned along the elongated cup at a point where when the elongated protrusion is fractured an opening will be formed at the closed end of the elongated

cup whereby said elongated cup is inserted into the tubular housing to seal the liquid within the tubular housing wherein upon bending the tubular housing near the closed end of the elongated cup the elongated protrusion will fracture from the elongated cup at the fracture line and a liquid flow path is exposed to allow the liquid to be released from the tubular housing.

27. A sealed container with enclosed opening means comprising an elongated tubular housing with a sealed end and an open end, an elongated member affixed to said sealed end, a liquid enclosed within the elongated tubular housing near the sealed end, an enclosed opening means with an elongated member disposed inside the elongated tubular housing sealing the liquid within the elongated tubular housing with the elongated member extending towards the open end of the elongated tubular housing wherein the opening means may be operated to release the liquid from the elongated tubular housing.

28. A sealed container with enclosed opening means as in claim 27, wherein said enclosed opening means comprises of a cylinder with an outside diameter approximately that of the inside diameter of said elongated tubular housing defining a liquid flow path from the liquid to the open end of said elongated tubular housing and an elongated protrusion that is separable from the cylinder extending from an end of the cylinder near the liquid and sealing the liquid flow path.

29. A sealed container with enclosed opening means as in claim 27, wherein said enclosed opening means comprises of a hollow cylindrical body with an open end disposed toward the liquid and a sealed end with an elongated member extending therefrom to the open end of the elongated tubular housing with a frangible section formed on the hollow cylindrical body near the sealed end of the hollow cylindrical body.

30. A sealed container with enclosed opening means as in claim 27, wherein said enclosed opening means comprises of a deformable cup.

31. A sealed container with enclosed opening means as in claim 27, wherein said enclosed opening means comprises of a deformable sphere.

32. A sealed container with enclosed opening means as in claim 27, wherein said enclosed opening means comprises of a plug that is fracturable at a fracture surface wherein said plug has one or more holes extending from each end of the plug that extend pass the fracture surface without passing through the other end of the plug wherein upon bending of the tubular housing at or near the plug the plug will fracture at said fracture surface and one or more liquid flow paths are formed leading from the liquid to the open end of the tubular housing.

33. A sealed container with enclosed opening means as in claim 32, wherein said plug may also be fracturable or separable when it is twisted wherein when the tubular housing is twisted at the opening means to open the liquid flow path.

34. A sealed container with enclosed opening means as in claim 27, wherein said enclosed opening means comprises of a cylindrical section with a reduced outside diameter waist section and two ends with outside diameters approximately that of the inside diameter of the tubular housing wherein said cylindrical section defines a through hole in its axial direction forming a liquid flow path from the liquid to the open end of the tubular housing and an elongated member affixed to the sealed end of said tubular housing and

extending into the hole in the cylindrical section thereby sealing the hole and the liquid flow path wherein when the tubular housing is bent or pulled at or near the cylindrical section the elongated member will be pulled out of the hole in the cylindrical section and the liquid flow path from the liquid to the open end of the tubular housing is exposed.

35. A sealed container with enclosed opening means as in claim 27, wherein said enclosed opening means comprises of two circular discs with approximately the same cross-section as the inside diameter of the tubular housing and with sufficient thickness to prevent them from flipping inside the tubular housing wherein each circular disc has one or more holes through it positioned such that when the two circular discs are placed next to each other in the tubular housing the holes in each circular disc will be covered by the other disc thereby all the holes in both circular discs are sealed by the other circular disc and when the tubular housing is bent at or near the two circular discs the deformation of the tubular housing will cause the two circular discs to separate from each other and a liquid flow path will result.

36. A sealed container with enclosed opening means as in claim 35, wherein said separation between the two circular discs is formed by twisting the tubular housing.

37. A sealed container with enclosed opening means as in claim 27, wherein said enclosed opening means comprises of a cylindrical section with sufficient length to prevent it from turning inside the tubular housing and with a diagonal slit formed diagonally from one end to the other with a thin section of material connecting the two halves of the cylindrical section and sealing the liquid in the tubular housing behind the cylindrical section wherein when the cylindrical section is compressed by squeezing the tubular housing the two halves of the cylindrical section will slide against each other and press together thereby reducing the cross-section of the cylindrical section to form a liquid flow path between the outside of the cylindrical section and the inside wall of the tubular housing to allow the liquid to be released from the tubular housing.

38. A sealed container with enclosed opening means as in claim 27, wherein said enclosed opening means comprises of a section of material with approximately the same diameter near its mid-section as the inside diameter of the tubular housing with a first end of the section of material formed in the form of two prongs that will act as handles wherein opposing forces can be applied by squeezing the two prongs toward each other and a second end of the section of material with a smaller cross-section than the inside diameter of the tubular housing and a fracture surface formed from the second end to near where the two prongs at the first end are joined whereby when the two prongs are squeezed toward each other by squeezing the tubular housing, the section of material will fracture into two halves along the fracture surface along its longitudinal direction and open a liquid flow path through the section of material to allow the release of the liquid from the tubular housing.

39. A sealed container with enclosed opening means as in claim 27, wherein said enclosed opening means comprises of an elongated cup with a diameter approximately that of the inside diameter of the tubular housing and a length that is longer than the diameter with a closed end terminate in an elongated protrusion with a fracture line formed around the elongated protrusion positioned along the elongated cup at a point where when the elongated protrusion is fractured an opening will be formed at the closed end of the elongated cup whereby said elongated cup is inserted into the tubular housing to seal the liquid within the tubular housing wherein upon bending the tubular housing near the closed end of the elongated cup the elongated protrusion will fracture from the elongated cup at the fracture line and a liquid flow path is exposed to allow the liquid to be released from the tubular housing.

* * * * *