



US 20060021171A1

(19) **United States**

(12) **Patent Application Publication**

Niccolai

(10) **Pub. No.: US 2006/0021171 A1**

(43) **Pub. Date: Feb. 2, 2006**

(54) **DEVICE FOR WRINGING OUT THE MATERIAL OF DOMESTIC CLEANING TOOLS KNOWN AS MOPS**

Publication Classification

(51) **Int. Cl.**
A47L 13/142 (2006.01)
(52) **U.S. Cl.** **15/120.1**

(76) **Inventor: Celestino Niccolai, Pistoia (IT)**

Correspondence Address:
MCGLEW & TUTTLE, PC
P.O. BOX 9227
SCARBOROUGH STATION
SCARBOROUGH, NY 10510-9227 (US)

(57) **ABSTRACT**

The device comprises: a sleeve (5) with slots or holes (5C), capable of accommodating the tool (1, 1A) that is to be wrung; the sleeve is extended in the form of a handgrip (7) which is axially perforated to allow the stick (3) to be accommodated inside it in a sliding manner; and a wringer element (9) in the form of flexible helical turns (9C) is engaged on the terminal edge (5B) of the sleeve (5) and at the other end forms an extension (9F) that can be fitted onto and coupled rotationally to the stick (3) of the tool. The tool is wrung out by torsion.

(21) **Appl. No.: 10/526,447**

(22) **PCT Filed: Aug. 4, 2003**

(86) **PCT No.: PCT/IT03/00498**

(30) **Foreign Application Priority Data**

Sep. 3, 2002 (IT) FI2002A000162

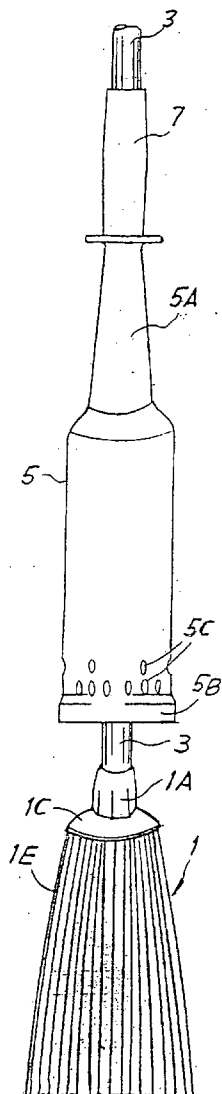

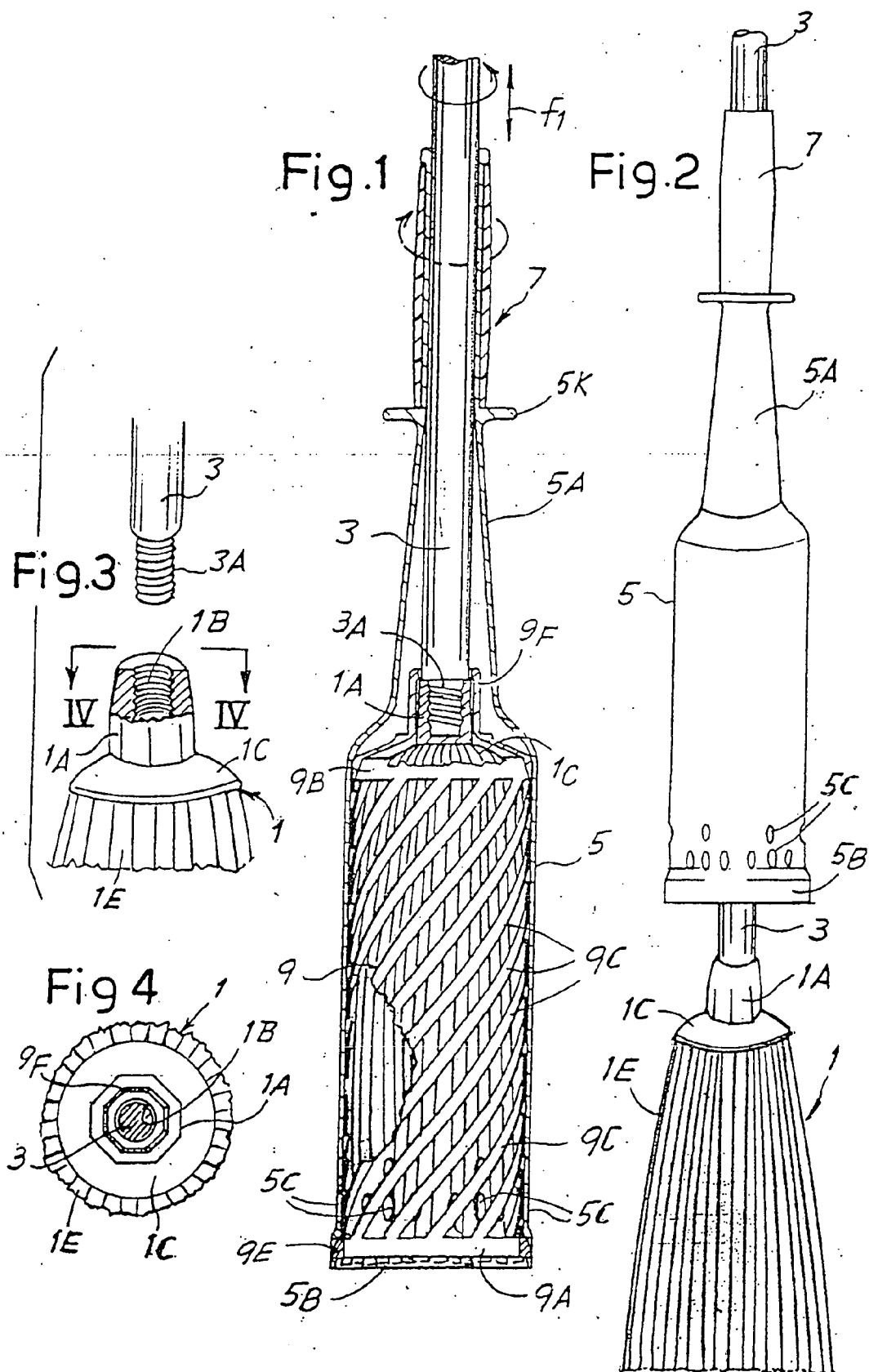

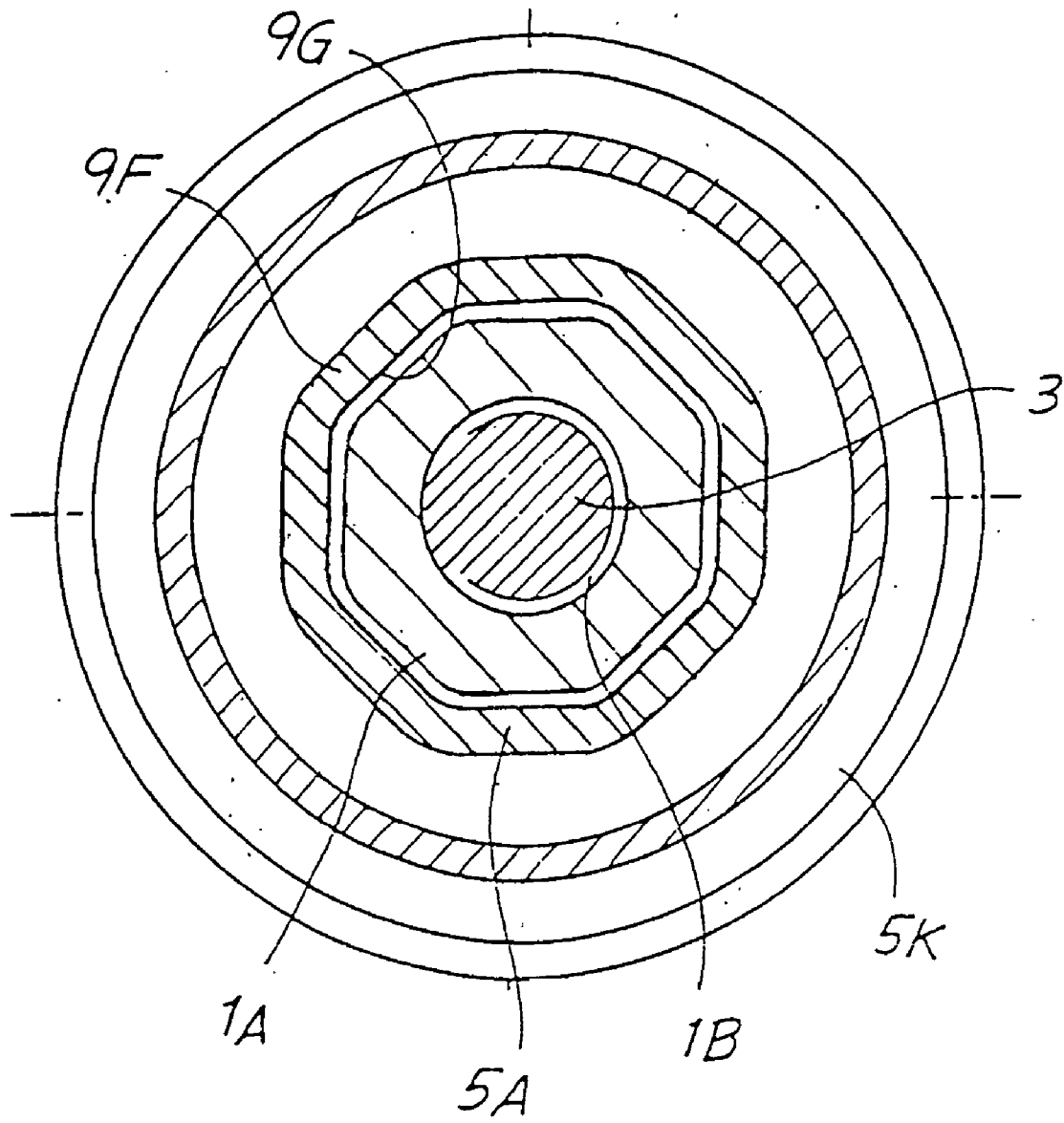

Fig. 5

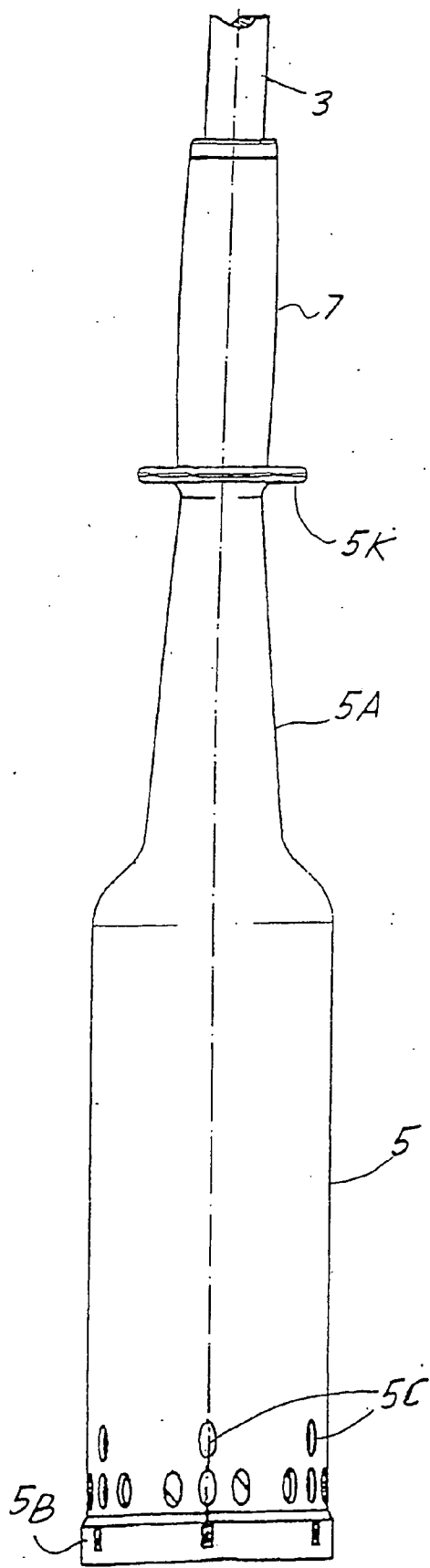

Fig.6

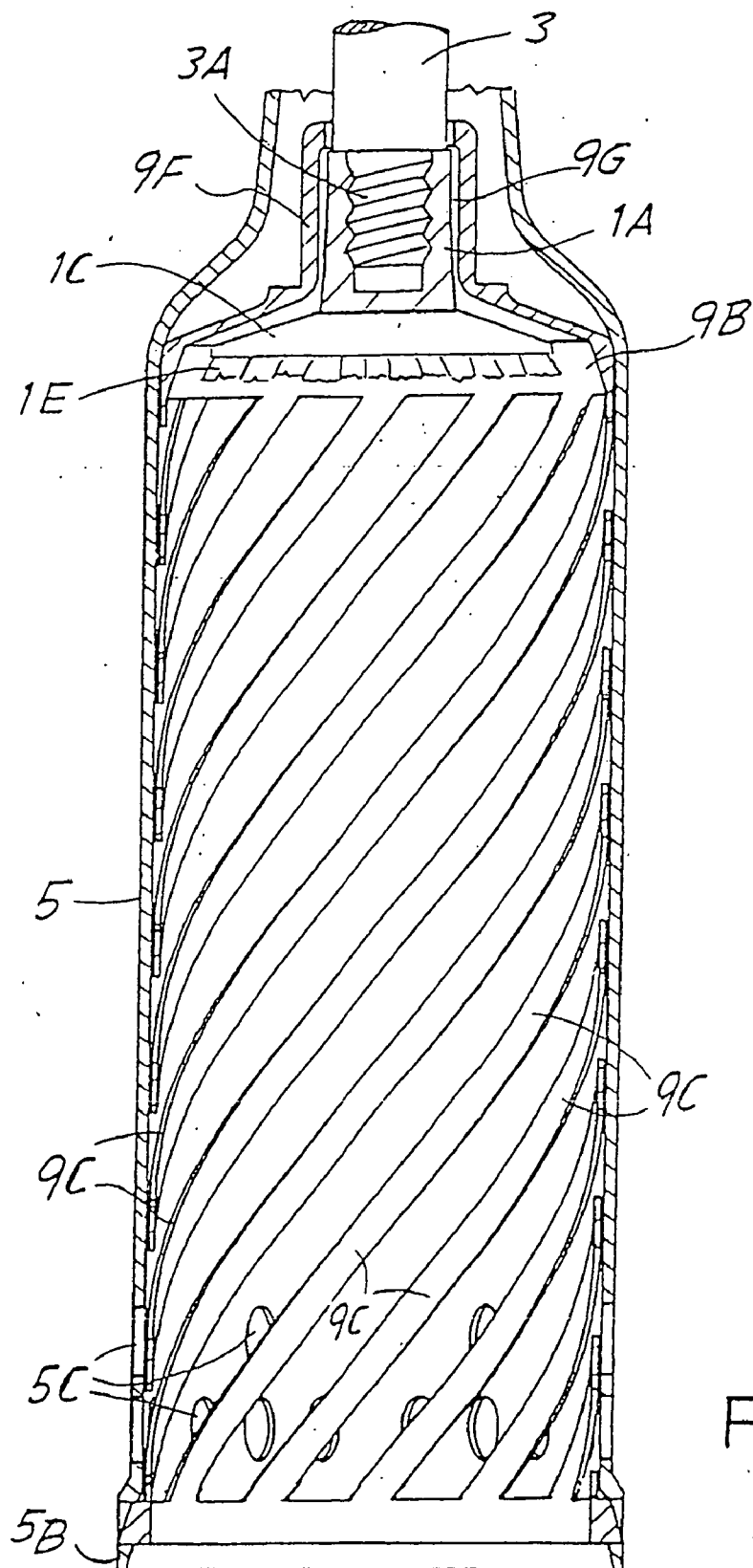

Fig.7

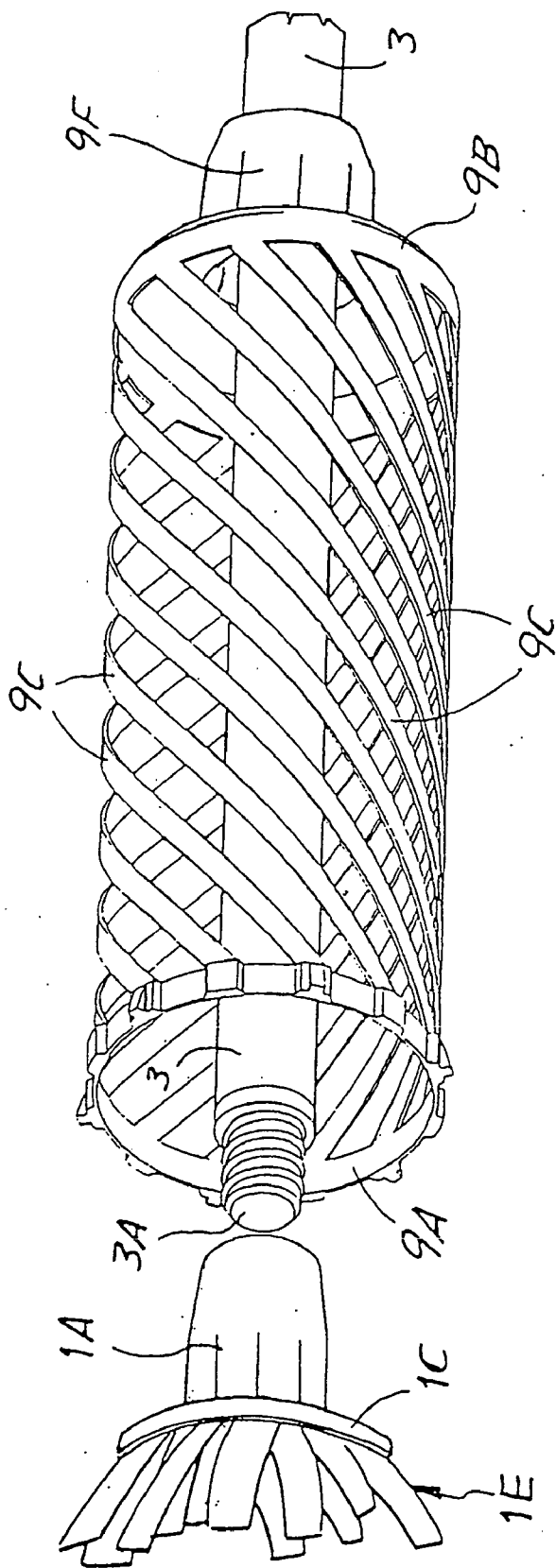

Fig.8

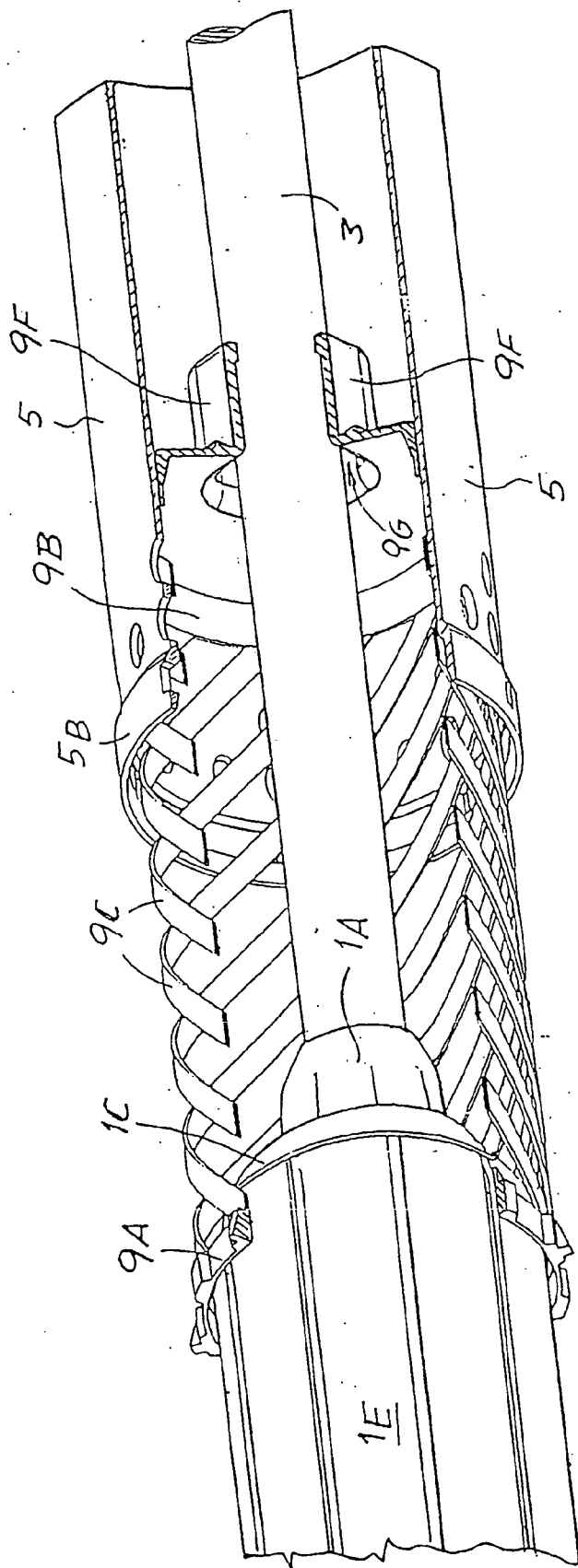

Fig.9

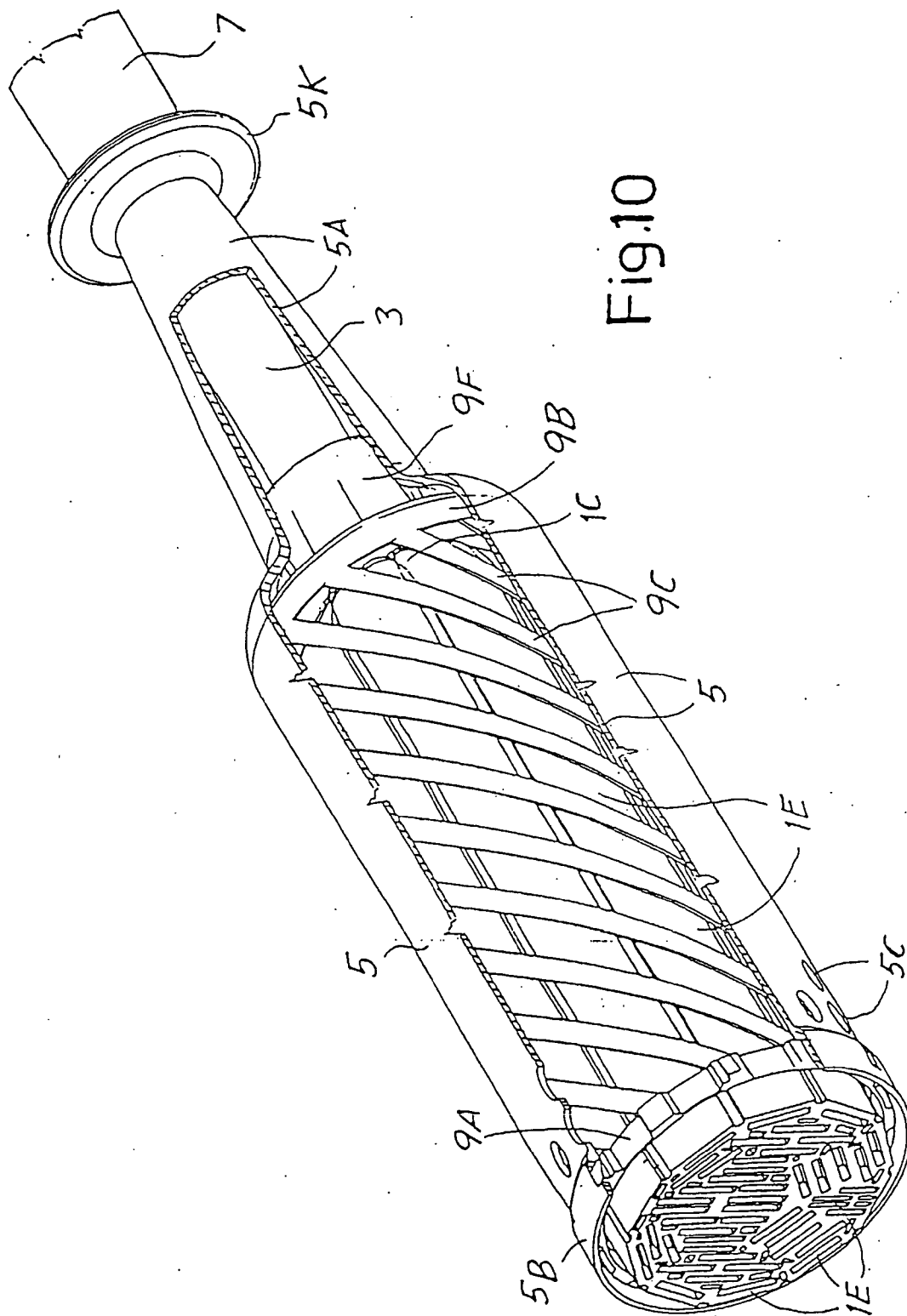

Fig.10

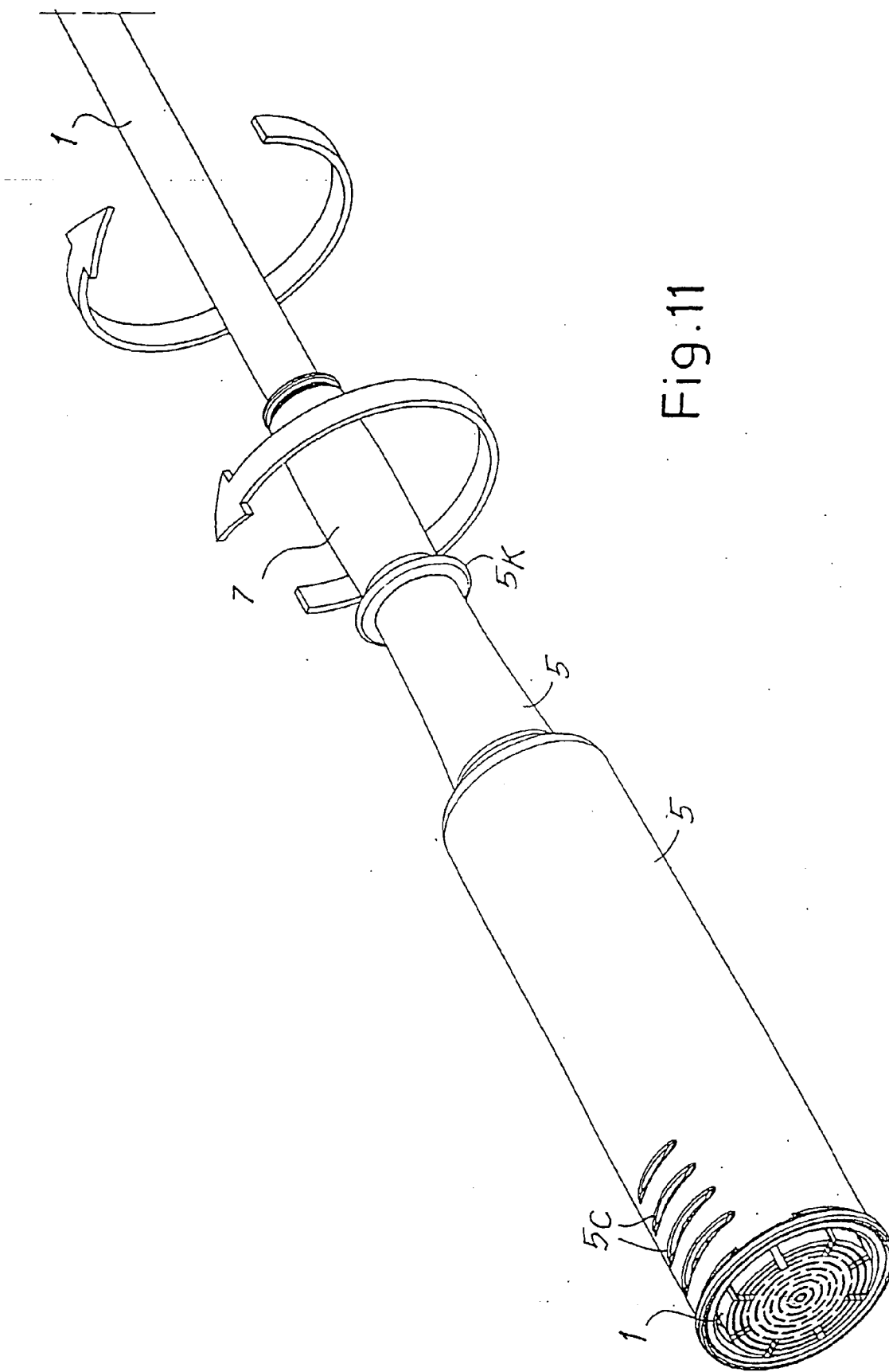

Fig.11

DEVICE FOR WRINGING OUT THE MATERIAL OF DOMESTIC CLEANING TOOLS KNOWN AS MOPS

[0001] The prior art includes devices for wringing out domestic cleaning tools of the mop type (comprising a plurality of flexible absorbent strips or filaments of cotton or the like), which comprise by way of a wringer element a tubular member with multiple helical turns which, when torsion is applied between the two ends of said element, produces a centripetal radial compression of the tool which has been inserted axially inside the turns.

[0002] Wringer devices of this kind are disclosed in U.S. Pat. Nos. 5,060,338 and 5,724,694, in Canadian Patent Appl. No. 2 336 517, in FR Pat. No. 848 688, and in CH Pat. No. 178 794 and No. 287 161.

[0003] The invention relates to an improved and simplified device that is also more practical for the user to use.

[0004] The device in question essentially comprises: a sleeve with holes, capable of accommodating the tool and being extended in the form of a handgrip which is axially perforated to allow the stick to which the tool is attached to be accommodated in it in a sliding manner; and a wringer element in the form of flexible helical turns extending between an inner annular extremity and an outer annular extremity, the outer annular extremity being engaged on the terminal edge of the sleeve and the inner annular extremity forming an extension that can be fitted onto and coupled rotationally to the stick of the tool. Wringing is performed by a longitudinal movement between the stick of the tool and the device, to pass the tool into the wringer element inside the sleeve, a torsional movement between the tool and the device, and the corresponding reverse movements.

[0005] In practice, the extension of the inner annular extremity of the wringer element has a cavity that is at least partly of polygonal and in particular octagonal or optionally square section; the tool in turn has a head shaped correspondingly so as to fit into said cavity of the extension of the wringer element, thus bringing about rotational coupling with the stick.

[0006] The head of the tool is screwed onto the end of the stick so as to be removable from it; easy replacement of the worn tool is thus possible.

[0007] A clearer understanding of the innovation will be gained from the description and the accompanying drawing, the latter showing a practical, non-restrictive example of the innovation. In the drawing:

[0008] FIG. 1 shows a sectional view of the device;

[0009] FIG. 2 shows a view of the device when the tool is outside the sleeve;

[0010] FIG. 3 shows a detail view of the threaded attachment between the stick and the tool;

[0011] FIG. 4 shows a top view of the tool taken on IV-IV as marked in FIG. 3;

[0012] FIG. 5 shows a cross sectional view of the device;

[0013] FIG. 6 shows the device when the tool is retracted into the sleeve;

[0014] FIG. 7 shows a partial sectional view of the device when the tool is retracted into the sleeve;

[0015] FIG. 8 shows a perspective view of the wringer element, the stick and the tool;

[0016] FIG. 9 shows a partial perspective view of the mechanism whereby the stick is slid into the axially perforated handgrip;

[0017] FIG. 10 shows a cut-away view, when the tool is retracted inside the sleeve; and

[0018] FIG. 11 illustrates the wringing operation.

[0019] As illustrated in the accompanying drawing, **1** is a general reference for the mop-type tool which comprises a head **1A**, which is at least partly of octagonal (or more generally polygonal) section and terminates with a lead-in chamfer around a threaded hole **1B** for receiving the threaded end **3A** of the stick **3** with which the tool **1** is worked. The tool **1** is completed by a plurality of strips **1C** of flexible and absorbent material: these do the cleaning and must be wrung out frequently to expel the dirty cleaning liquid and enable the cleaning operation to be continued.

[0020] It is precisely to simplify the wringing out of the strips or cords of cotton **1C** of the tool **1** that the present device is provided, in combination with the stick **3** and with the tool **1** mounted on this stick.

[0021] The device in question comprises a cylindrical sleeve **5** that continues at **5A** to form at its end a handgrip **7**, which may optionally be padded with a thickness of e.g. rubber or other material. Towards the terminal edge **5B** of the sleeve **5** are holes, especially slots, **5C** for the expelled water to drain out, and windows and molded regions to receive a wringer element (described below) which is housed inside the sleeve **5**, and into which the tool **1** is to be inserted. This wringer element, indicated by the general reference **9**, comprises an outer annular extremity **9A** and an inner annular element **9B**, the two annular elements **9A** and **9B** being connected to each other by a plurality of helical turns **9C** of ribbonlike form in order to be contained within an essentially cylindrical virtual geometrical surface on the inside of the sleeve **5**. The outer annular extremity **9A** is provided with protuberances **9E** which engage firmly in the corresponding windows and molded regions created in the terminal edge **5B** of the sleeve **5**. The inner annular extremity **9B** of the wringer element forms an extension **9F** containing a cavity **9G** which in cross section is at least partly polygonal and in particular octagonal in order to be able to accommodate and engage angularly with the head **1B** of the tool **1** by a relative axial movement. In this way, the assembly formed by the tool **1** with its stick **3** engages in rotation with the annular extremity **9B** of the wringer element **9**, when the stick **3** and tool **1** are slid as shown by arrow **f1** relative to the sleeve **5** and to the wringer element. Essentially, the assembly of the stick **3**, which is housed in the extension **5A** and inside the handgrip **7**, can slide relative to the sleeve **5** with its extension **5A**, **7** axially, moving the tool **1** together with its head **1A** engaged on the thread **3A** of the stick **3**. The tool **1** with the stick **3** can thus be slid in the direction of arrow **f1** in order to insert the tool **1** into the wringer element **9** when said element is held within the turns **9C** dilated and in contact with the inner surface of the sleeve **5**, and in order to extend the tool **1** out of the sleeve **5** in the opposite direction to arrow **f1** to enable the tool **1** to be used,

by immersing it in a cleaning liquid and manipulating it to clean a floor or the like. The tool 1 on the end of the stick 3 can easily be replaced by simply unscrewing the head 1A of said tool 1 from the thread 3A and replacing the worn tool with another tool ready for use.

[0022] To use the tool 1 as a mop, it is extended from the sleeve 5 as shown in FIG. 2 and used with the aid of the stick 3, which projects below the edge 5B and above the handgrip 7. The wringer element 9 remains engaged inside the sleeve 5 with its turns dilated. When it is wished to wring out the strips 1C of the tool 1 to expel the dirty liquid, the stick 3 is slid in the direction of arrow f1 to draw the tool 1, 1A with its strips 1C inside the wringer element 9. The octagonal-section head 1A is thus advanced into the cavity 9G, which is of corresponding shape, inside the extension 9F of the inner annular extremity 9B of the wringer element 9. The inner extremity 9B of the wringer element 9 is thus engaged on the stick 3. By rotating the stick 3 relative to the assembly 5, 5A, 7 as indicated by the two opposed arrows shown in FIGS. 2 and 11, a reciprocal torsion is set up between the outer 9A and inner 9B extremities of the wringer element 9. The effect of this rotation is to tighten the helical turns 9C so causing radial compression of the strips 10 by the helical turns 9C and expelling the liquid from the strips 1C. The liquid runs out at the holes 5C and is thus removed. The extreme ends of the strips 1C remain at least partly unwrung, i.e. in the regions in which the helical turns are joined to the outer 9A and inner 9B extremities, where these helical turns cannot be constricted radially; however, the greater part of these helical turns 9C is easily tightened, compacting and squeezing the mass of strips 1C. The tool 1 can then be easily extended again from the sleeve 5 and from the wringer element 9 by simply rotating the assembly 5, 5A, 7 and the stick 3 in the opposite directions to those indicated in FIG. 1, this operation causing the turns 9C to open again until they are back in contact with the inner surface of the sleeve 5; immediately after which the tool 1 can be extended by pushing the stick in the opposite direction to arrow f1 relative to the assembly 5, 5A, 7 until the tool 1 is outside the sleeve 5, that is in the condition shown in FIG. 2.

[0023] The device disclosed herein, comprising the components 5, 7, 9, remains engaged on the stick 3 and the tool 1 can, as already indicated, easily be replaced, when worn, simply by unscrewing the head 1A from the thread 3A of the stick 3 and attaching a new tool 1 to this stick.

[0024] A handgrip similar to the handgrip 7, and adjacent to the latter, can be put on the stick 3 to facilitate wringing operations.

[0025] It will be understood that the drawing shows only an example, purely as a practical demonstration of the innovation, which innovation can be varied in its shapes and arrangements without thereby departing from the scope of the concept on which the innovation is based. The presence of any reference numbers in the appended claims is for the purpose of facilitating the reading of the claims with reference to the description and drawing, and does not limit the scope of protection represented by the claims.

1. A device for wringing out flexible strips (1C) of absorbent material of a domestic cleaning tool (1, 1A) known as a mop, equipped with a stick (3), said device being characterized in that it comprises in combination: a sleeve (5) with holes or slots (5C), capable of accommodating the tool (1, 1A, 1C) and being extended in the form of a handgrip (7) having an axial hole through which said stick (3) can be passed; and a wringer element (9) in the form of flexible helical turns (9C) extending between an inner annular extremity (9B) and an outer annular extremity (9A), the outer annular extremity (9A) being engaged on the terminal edge (5B) of the sleeve (5) and the inner annular extremity (9B) forming an extension (9F) that can be fitted onto and coupled rotationally to the stick (3) of the tool; wringing being performed by a longitudinal movement between the stick (3) of the tool (1) and the device (5), to pass the tool (1) into the wringer element (9) inside the sleeve (5), and a torsional movement between the tool and the device, and by the corresponding reverse movements.

2. Device according to the previous claim, characterized in that said extension (9F) of the inner annular extremity (9B) of the wringer element (9) has a cavity (9G) that is at least partly of polygonal, and in particular octagonal, section, and the tool (1) has a head (1A) shaped correspondingly so as to fit into said cavity (9G) of said extension (9F) of the wringer element (9), so as to be coupled rotationally to the stick (3).

3. Device according to claim 2, characterized in that said head (1A) of the tool (1) is screwed onto the end (3A) of the stick (3) so as to be, removable from it, in such a way as to allow easy replacement of the worn tool (1).

4. Device for wringing out the material of domestic cleaning tools known as mops; the whole as described above and as illustrated by way of example in the accompanying drawing.

* * * * *