

(12) STANDARD PATENT
(19) AUSTRALIAN PATENT OFFICE

(11) Application No. **AU 2008240254 B2**

(54) Title
Flotation separation device and method

(51) International Patent Classification(s)
B03D 1/00 (2006.01) **B03D 1/14** (2006.01)
B03D 1/02 (2006.01)

(21) Application No: **2008240254** (22) Date of Filing: **2008.04.11**

(87) WIPO No: **WO08/128044**

(30) Priority Data

(31) Number	(32) Date	(33) Country
60/911,327	2007.04.12	US

(43) Publication Date: **2008.10.23**

(44) Accepted Journal Date: **2012.11.08**

(71) Applicant(s)
Eriez Manufacturing Co.

(72) Inventor(s)
Yan, Eric S.;Luttrell, Gerald H.;Kohmuench, Jaisen;Mankosa, Michael J.

(74) Agent / Attorney
Fisher Adams Kelly, Level 29 12 Creek Street, Brisbane, QLD, 4000

(56) Related Art
DE 3808154 A1 (J.M. VOITH) 21 September 1989
US 5167798 A (Yoon et al.) 01 December 1992
WO 00/15343 A1 (JAMESON) 23 March 2000

(12) INTERNATIONAL APPLICATION PUBLISHED UNDER THE PATENT COOPERATION TREATY (PCT)

(19) World Intellectual Property Organization
International Bureau



(43) International Publication Date
23 October 2008 (23.10.2008)

PCT

(10) International Publication Number
WO 2008/128044 A1

- (51) **International Patent Classification:**
B03D 1/00 (2006.01) *B03D 1/14* (2006.01)
B03D 1/02 (2006.01)
- (21) **International Application Number:** PCT/US2008/060035
- (22) **International Filing Date:** 11 April 2008 (11.04.2008)
- (25) **Filing Language:** English
- (26) **Publication Language:** English
- (30) **Priority Data:** 60/911,327 12 April 2007 (12.04.2007) US
- (71) **Applicant (for all designated States except US):** **ERIEZ MANUFACTURING CO.** [US/US]; 2200 Ashbury Road, Erie, PA 16506 (US).
- (72) **Inventors; and**
- (75) **Inventors/Applicants (for US only):** **MANKOSA, Michael, J.** [US/US]; 6243 Cobblestone Drive, Erie, PA 16509 (US). **KOHMUENCH, Jaisen** [US/US]; 4051 Roxbury Road, Erie, PA 16506 (US). **YAN, Eric, S.**
- [—/US]; 4173 Stone Creek Drive, Eric, PA 16506 (US). **LUTTRELL, Gerald, H.** [US/US]; 1907 Shadow Lake, Blacksburg, VA 24060 (US).
- (74) **Agents:** **D'SILVA, Jonathan, M.** et al.; MacDonald, Illig, Jones and Britton LLP, 100 State Street - Suite 700, Erie, PA 16507-1459 (US).
- (81) **Designated States (unless otherwise indicated, for every kind of national protection available):** AE, AG, AI, AM, AO, AT, AU, AZ, BA, BB, BG, BH, BR, BW, BY, BZ, CA, CH, CN, CO, CR, CU, CZ, DE, DK, DM, DO, DZ, EC, EE, EG, ES, FI, GB, GD, GE, GH, GM, GT, HN, HR, HU, ID, IL, IN, IS, JP, KE, KG, KM, KN, KP, KR, KZ, LA, LC, LK, LR, LS, LT, LU, LY, MA, MD, ME, MG, MK, MN, MW, MX, MY, MZ, NA, NG, NI, NO, NZ, OM, PG, PH, PL, PT, RO, RS, RU, SC, SD, SE, SG, SK, SL, SM, SV, SY, TJ, TM, TN, TR, TT, TZ, UA, UG, US, UZ, VC, VN, ZA, ZM, ZW.
- (84) **Designated States (unless otherwise indicated, for every kind of regional protection available):** ARIPO (BW, GH, GM, KE, LS, MW, MZ, NA, SD, SI, SZ, TZ, UG, ZM,

[Continued on next page]

(54) **Title:** FLOTATION SEPARATION DEVICE AND METHOD

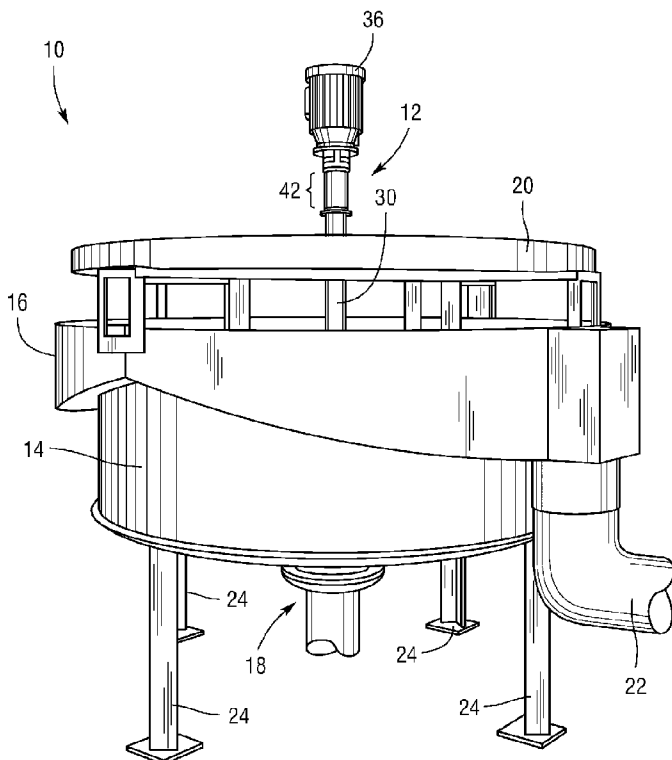

Fig.1

(57) **Abstract:** A flotation separation system for partitioning a slurry that includes a hydrophobic species which can adhere to gas bubbles formed in the slurry. The flotation separation system comprises a flotation separation cell including a sparger unit and separation tank. The sparger unit has inlets for slurry and for a gas with at least enough pressure to allow bubbles to form in the slurry within the sparger unit. The sparger unit includes a sparging mechanism constructed to disperse gas bubbles within the slurry. The sparging mechanism sparges the gas bubbles to form a bubble dispersion to cause adhesion of the hydrophobic species to the gas bubbles substantially within the sparger unit while causing a pressure drop of about 10 psig or less across the sparging mechanism. The sparger unit includes a slurr outlet to discharge the slurry and the bubble dispersion into the separation tank.

WO 2008/128044 A1



ZW), Eurasian (AM, AZ, BY, KG, KZ, MD, RU, TJ, TM),
European (AT, BE, BG, CH, CY, CZ, DE, DK, EE, ES, FI,
FR, GB, GR, HR, HU, IE, IS, IT, LT, LU, LV, MC, MT, NL,
NO, PL, PT, RO, SE, SI, SK, TR), OAPI (BF, BJ, CF, CG,
CI, CM, GA, GN, GQ, GW, ML, MR, NE, SN, TD, TG).

- *as to the applicant's entitlement to claim the priority of the earlier application (Rule 4.17(iii))*
- *of inventorship (Rule 4.17(iv))*

Declarations under Rule 4.17:

- *as to the identity of the inventor (Rule 4.17(i))*
- *as to applicant's entitlement to apply for and be granted a patent (Rule 4.17(ii))*

Published:

- *with international search report*
- *before the expiration of the time limit for amending the claims and to be republished in the event of receipt of amendments*

Flotation Separation Device and Method

Background

Flotation separators are used extensively throughout the minerals industry to partition and recover the constituent species within slurries. A slurry is a mixture of liquids (usually water) with various species having varying degrees of hydrophobicity. The species could be insoluble particulate matter such as coal, metals, clay, sand, etc. or soluble elements or compounds in solution. Flotation separators work on the principle that the various species within the slurry interact differently with bubbles formed in the slurry. Gas bubbles introduced into the slurry attach, either through physical or chemical means, to one or more of the hydrophobic species of the slurry. The bubble-hydrophobic species agglomerates are sufficiently buoyant to lift away from the remaining constituents and are removed for further processing to concentrate and recover the adhered species. Various methods used to achieve this process typically require significant energy to inject gas into the slurry and form a bubble dispersion.

Summary

A flotation separation system is provided for partitioning a slurry that includes a hydrophobic species which can adhere to gas bubbles formed in the slurry. The flotation separation system comprises a flotation separation cell that includes a sparger unit and a separation tank. The sparger unit has a slurry inlet for receiving slurry and a gas inlet to receive gas with at least enough pressure to allow bubbles to form in the slurry within the sparger unit. The sparger unit includes a sparging mechanism constructed to disperse gas bubbles within the slurry. The sparging mechanism sparges the gas bubbles to form a bubble dispersion so as to cause adhesion of the hydrophobic species to the gas bubbles substantially within the sparger unit while causing a pressure drop of about 10 psig or less across the sparging mechanism. The sparger unit includes a slurry outlet to discharge the slurry and the bubble dispersion into the separation tank. The separation tank has

06216.0205.03

sufficient capacity to allow the bubble dispersion to form a froth at the top of the separation tank. Various embodiments of the flotation separation system can include a center well that surrounds the sparging unit.

In one embodiment, the sparging mechanism of the sparger unit includes a high-shear element to help shear the bubbles formed in the slurry into a bubble dispersion. The high-shear element can include rotating high-shear elements or a combination of rotating and static high-shear elements. Rotating high shear elements can comprise a series of rotating elements along the length of the sparging unit. The high-shear element can alternatively comprise a series of grooved discs pressed together to form channels from the gas inlets to the slurry with gas passing through the channels to reach the slurry. Other possible embodiments and variations are discussed in more detail herein.

Those skilled in the art will realize that this invention is capable of embodiments that are different from those shown and that details of the devices and methods can be changed in various manners without departing from the scope of this invention. Accordingly, the drawings and descriptions are to be regarded as including such equivalent embodiments as do not depart from the spirit and scope of this invention.

Brief Description of Drawings

For a more complete understanding and appreciation of this invention, and its many advantages, reference will be made to the following detailed description taken in conjunction with the accompanying drawings.

FIG. 1 is a perspective view of a flotation separation cell with one sparger unit;

FIG. 2 is a perspective view of a flotation separation cell with three sparger units;

FIG. 3 is an embodiment of a sparger unit;

06216.0205.03

FIG. 4 is a view of an embodiment of a sparger unit showing the rotating high-shear element of the sparging mechanism;

FIG. 5 is a view of an embodiment of a sparger unit showing the rotating and static high-shear elements of the sparging mechanism;

FIG. 6A is a view of an embodiment of a sparger unit in which the sparging mechanism has gas inlets along its length;

FIG. 6B is a view of the sparging mechanism of the sparger unit of FIG. 6A;

FIG. 6C is a close up of a check valve of a gas inlet of FIG. 6A;

FIG. 6D is a gas inlet of FIG 6A;

FIG. 6E is a different view of the gas inlet of FIG 6D;

FIG. 7A is an embodiment of a sparger unit that does not use an electric motor;

FIG. 7B is a view of the sparger unit of FIG. 7A showing the sparging mechanism with the high shear element comprising a series of grooved discs;

FIG. 7C is a view of the high shear element of FIG. 7B;

FIG. 7D is a view of the high shear element of FIG. 7B without the grooved discs;

FIG. 7E is a view of a grooved disc of FIG. 7B;

FIG. 8 is a view of an alternative embodiment of the grooved discs of FIG. 7B;

FIG. 9A is an embodiment of a sparger unit with a cleaning system for the sparging unit;

FIG. 9B is a close up of the sparger unit of FIG 9A without the grooved discs;

FIG. 9C is an exploded view of the sparger unit of FIG 9A;

FIG. 10 is a sparger unit in which the sparging mechanism is a high frequency linear displacement device;

FIG. 11 is a view of an embodiment of a sparger unit showing a sparger mechanism having multiple banks of rotating high shear elements;

06216.0205.03

FIG. 12 is a representation of some of the control systems for a flotation separation cell;

FIG. 13 shows a flotation separation system that comprises a series of flotation separation cells in a modular vertical arrangement;

FIG. 14 shows a flotation separation system that comprises a series of flotation separation cells in a staggered horizontal arrangement;

FIG. 15 is a graph plotting the recovery of a target species versus process rate and retention time for various circuit configurations;

FIG. 16A shows a flotation separation system in which a flotation separation cell discharges slurry from the underflow removal port to the inlet of a conventional flotation cell;

FIG. 16B shows a flotation separation system in which a flotation separation cell discharges slurry from the underflow removal port to the inlet of a column flotation cell;

FIG. 17A shows an embodiment of a flotation separation cell that incorporates a center well;

FIG. 17B shows the center well shown in FIG 17A showing the sparger unit within the center well;

FIG. 18A shows a different embodiment of a flotation separation cell in which the center well liquid level is maintained by adjusting the size of the orifices at the end of the center well based on pressure sensor readings;

FIG. 18B shows a different embodiment of a flotation separation cell in which the liquid level in the center well is maintained by adjusting the inflow of slurry to the flotation separation cell;

FIG. 18C shows a different embodiment of a flotation separation system comprising a number of flotation separation cells in series in which the liquid level in the center well for each flotation separation cell is maintained by adjusting the inflow of slurry to each flotation separation cell;

06216.0205.03

FIG. 19 is a perspective view of a flotation separation cell with four sparger units that feed slurry from the bottom of the separation tank;

FIG. 20 is a perspective view of a flotation separation cell with four sparger units that feed slurry through the sidewalls of the separation tank; and

FIG. 21 is a perspective view of a flotation separation cell in which the underflow removal port leaves through the side of the separation tank.

Detailed Description

Referring to the drawings, some of the reference numerals are used to designate the same or corresponding parts through several of the embodiments and figures shown and described. Corresponding parts are denoted in different embodiments with the addition of lowercase letters. Variations of corresponding parts in form or function that are depicted in the figures are described. It will be understood that variations in the embodiments can generally be interchanged without deviating from the invention.

Flotation separation is commonly used in the minerals industry to separate mineral species in suspension in liquid slurries. Such mineral species are often suspended with a mixture of unwanted constituent species. Flotation separators currently in common use require an extensive application of large amounts of energy for pressurizing gas, pressuring the slurry, increasing the flow velocity of the slurry, and/or maintaining the slurry in suspension.

However, effective flotation separation is possible with the embodiments depicted herein without the need for high energy consumption. In one embodiment, shown in FIG. 1, a flotation separation system comprises at least one flotation separation cell **10** in a hydraulic system for the partitioning and recovery of the constituents of a slurry. The flotation separation cell **10** comprises at least one sparger unit **12** in which gas is introduced into the slurry. The sparger unit **12** includes a sparging mechanism **42** for sparging gas into a bubble dispersion within the slurry. The sparging

06216.0205.03

mechanism 42 is configured such that slurry flow through it is substantially unrestricted. The effective open area in the sparging mechanism 42 is substantially the same as the effective open area in the sparger unit 12 upstream and downstream of the sparging mechanism 42. This ensures a low pressure drop across the sparging mechanism 42 that allows for a lower pressure and flow rate of slurry through the sparger unit 12 and represents a significant energy savings for the flotation separation system. The pressure drop across the sparging mechanism 42 is about 10 psig or less. The operation of various embodiments of sparger units 12 is described in further detail below.

The sparger unit 12 feeds the slurry and bubble dispersion mixture to a separation tank 14. The separation tank 14 comprises an overflow launder 16, an underflow removal port 18, and a froth washing system 20. The overflow launder connects to an overflow drain 22. The flotation separation cell 10 may be supported by legs 24 or by any other means required by the particular application. The flotation separation cell 10 may even be placed directly on the floor if warranted by the design of the facility to which the flotation separation cell 10 is installed. The separation tank 14 requires no additional equipment within the tank to assist in froth formation (as discussed in more detail below) or to maintain the slurry in suspension. This represents a further energy savings in the overall operation as compared to conventional flotation separation systems, column flotation separation systems, and packed column flotation separation systems. The operation of the flotation separation system is presented in more detail below.

The flotation slurries typically include hydrophobic and hydrophilic species. Flotation separation takes advantage of the differing hydrophobicity of these species. When bubbles of gas are introduced into the slurry, the hydrophobic species within the slurry tend to selectively adhere to the bubbles while hydrophilic species tend to remain in suspension. Sparging, or breaking up, the bubbles into a bubble dispersion of many smaller bubbles increases the available bubble surface area for hydrophobic species adhesion. The bubbles, with the adhered hydrophobic species, tend to rise

06216.0205.03

above the slurry and form a froth in the separation tank **14** that is easily separated from the remainder of the slurry for further processing to recover the adhered hydrophobic species. In the embodiment shown in FIG. 1 removal of the froth is accomplished by overflowing the froth from the separation tank **14** into the overflow launder **16** and draining the collected froth through the overflow drain **22** to downstream processes. The species not adhered to the froth remain in the slurry and are discharged through the underflow removal port **18** for further processing. Further processing can include a subsequent stage of froth formation to catch hydrophobic species that for whatever reason were not captured in the preceding step.

Flotation separation systems are typically part of larger hydraulic systems that process slurry over a number of steps. The liquid portion of the slurry is typically water. The chemistry of the slurry is often adjusted with additives to assist in recovering a target component depending on the constituent species of the slurry. Surface tension modifying reagents, also known as frothers, are often added to slurries to assist in bubble formation. There are many types of frothers, including alcohols, glycols, Methylisobutyl Carbinol (MIBC), and various blends.

Sometimes the target species for recovery from the slurry are naturally hydrophobic, for example coal. But in slurries in which the target species are not hydrophobic, chemicals additives, also known as collectors, are introduced to chemically activate them. Collectors include fuel oil, fatty acids, xanthates, various amines, etc.

Some target species are quasi-hydrophobic. For example, oxidized coal tends to be less hydrophobic and is more difficult to recover from a slurry than unoxidized coal. Chemical additives, called extenders, are used to increase their hydrophobicity. Examples of extenders are diesel fuels and other fuel oils.

Chemical additives called depressants are used to reduce the hydrophobicity of a species. For example, in the recovery of iron ore, various types of starches are used to depress the bubble

06216.0205.03

adhesion response of iron ore so that only silica can be floated in the froth from the slurry. If the depressants are not added, a portion of the iron ore will also adhere to bubbles and float within the froth.

Because the pH of the slurry can affect froth formation, other chemical additives are introduced to modify the pH of the slurry. Acids or bases are added as needed to adjust the pH depending on the composition of the slurry.

In mineral flotation, the recovery of a particular species is predominantly controlled and proportional to two parameters: reaction rate and retention time. Recovery can be generally represented by the following equation:

$$R = k T \quad [1]$$

Where R is the recovery of a particular species, k is the reaction rate of adhesion of a species to a bubble, and T is the retention time of the slurry in the flotation separation system. An increase in either parameter provides a corresponding increase in recovery, R. The reaction rate, k, for a process is indicative of the speed at which the flotation separation will proceed and can be a function of several parameters including, but not limited to, gas introduction rate, bubble size, species size, and chemistry. The reaction rate, k, is increased when these parameters are adjusted to maximize the probability that a hydrophobic species will collide with and adhere to a bubble and to reduce the probability that a hydrophobic species will detach from a bubble. The probability of attachment is controlled by the surface chemistry of both the species and the bubbles in the process stream and is increased when the probability of a collision between a hydrophobic species and a bubble increases. The probability of collision is directly proportional to the concentration of hydrophobic species within the sparging region. The probability of detachment is controlled by the hydrodynamics of the flotation separation cell. As such, aeration of the slurry prior to its introduction to a separation tank is the preferred method of sparging as this ensures that the maximum amount of floatable species is

06216.0205.03

concentrated within the sparging unit to obtain a high recovery of the hydrophobic species. The embodiments described herein aim to increase the reaction rate, k , which means that a lower retention time, T , and thereby a smaller separation tank, can be used to obtain a suitable recovery, R .

In the embodiments disclosed herein, the reaction rate, k , of Equation [1] is increased by forcing the bubble-particle contact with high particle and air bubble concentrations and imparting significant energy within the bubble/particle contacting zone. Recovery, R , can also be represented in turbulent systems described herein as a function of the bubble concentration, C_b , particle concentration, C_p , and specific energy input, E , as follows:

$$R \propto C_b C_p E \quad [2]$$

The embodiments disclosed herein efficiently pre-aerate slurry in the sparger units **12** of the flotation separation cell **10** prior to injection of the slurry and gas mixture into the separation tank **14**. Slurry introduced into the sparger unit **12** passes through a sparging mechanism **42**, described in more detail below. The sparging mechanism **42** sparges the gas in the slurry into a bubble dispersion creating a relatively large surface area for hydrophobic species attachment within the sparger unit **12** such that hydrophobic species adhesion to bubbles occurs substantially in the sparger unit **12** before the slurry and the bubble dispersion is discharged into the separation tank **14**. This approach ensures that bubbles are generated in the presence of the slurry prior to any dilution with wash water (if used), thus maintaining the maximum particle concentration (C_p). Additionally, the sparger assembly **30** is operated at a very high air fraction (>40%), insuring that the bubble concentration (C_b) is maximized. Finally, the design of the sparging mechanism **42** in the sparger unit **12** is such that maximum energy is imparted to the slurry for the sole purpose of bubble-particle contacting. As a result, the contact time is reduced by several orders of magnitude over prior art column and conventional flotation separators. After contacting, the slurry is discharged to the separation tank **14**

06216.0205.03

for phase separation (slurry and froth) and froth washing (if used). Since phase separation is a relatively quick process, the overall separation tank **14** size is significantly reduced.

The sparging mechanism **42** is configured such that slurry flow through it is substantially unrestricted. The effective open area in the sparging mechanism **42** is substantially the same as the effective open area in the sparger unit **12** upstream and downstream of the sparging mechanism **42**. This ensures a low pressure drop across the sparging mechanism **42** that allows for a lower pressure and flow rate of slurry through the sparger unit **12** and represents a significant energy savings for the flotation separation system. The pressure drop across the sparging mechanism **42** is about 10 psig or less. Nevertheless, the embodiments depicted herein are able to operate with pressure drops of about 1 psig or less.

As the bulk of the hydrophobic species adhesion to a bubble occurs in the sparging unit **12**, the flotation separation cell **10** does not require the slurry to be introduced at a high velocity and/or a high pressure. The slurry may be pumped under pressure into the sparger unit **12** if the hydraulics of the flotation separation system require, but this need only be sufficient to provide enough hydraulic pressure for the slurry to flow through the flotation separation system. Slurry can be introduced into the flotation separation cell **10** at the slurry inlet of the sparger unit **12** at a hydraulic pressure of about 25 psig or less. The embodiments depicted herein are able to operate at slurry introduction hydraulic pressures of 2 psig or less.

The relatively low hydraulic pressure gradient that the slurry must overcome represents an energy savings during the operation of the flotation separation cell **10**. The hydraulics of a flotation separation cell **10** can be adjusted in various embodiments by, for example, adjusting the height of the sparger units **12** in relation to the height of the slurry in the separation tank **14** or by adjusting the entry point of slurry to the flotation separation cell **10**.

06216.0205.03

Similarly, the sparging mechanisms **42**, described in more detail below, do not require gas to be introduced at a high pressure. The gas introduction pressure need only be high enough to form bubbles in the slurry and the sparging mechanisms **42** described herein will sparge the bubbles into effective bubble dispersions. The low pressure and flow requirements for both slurry and gas introduction represent significant energy savings when compared to conventional flotation separation systems, column flotation separation systems, and packed column flotation separation systems.

As has been already discussed, with an increase in the rate of reaction provided by the method of pre-aeration, there is a corresponding decrease in the required retention time for a given application. Therefore the same flotation recovery can be obtained in a smaller volume than with prior art systems. As the bubble and species attachment substantially occurs in close proximity to the sparging mechanism **42** in the sparger units **12**, described in more detail below, and not within the separation tank **14** itself, the separation tank **14** is only required to provide time for the slurry and bubble phases to separate. A smaller separation tank **14** can be utilized without additional equipment in the separation tank when compared to conventional flotation separation systems, column flotation separation systems, and packed column flotation separation systems. The smaller and simpler flotation separation cell **10** allows for greater flexibility in designing flotation separation systems for particular applications. Energy is also not consumed to maintain the slurry in suspension in the separation tank **14**.

Because the separation tank **14** is used solely for froth separation, and does not require any additional equipment to maintain the slurry in suspension, the embodiments described herein are able to maintain a relatively deep froth in the separation tank **14** with no additional turbulence imparted to the separation tank **14**. Therefore, unlike with conventional flotation separation systems, the addition of wash water from the froth washing system **20** (described in more detail below) to

06216.0205.03

clean the froth does not affect the retention time of the froth in the separation tank **14**. It is therefore possible to have effective froth washing in the flotation separation systems described herein.

As the energy input to the system is focused specifically on creating fine bubbles and not in maintaining the particles in suspension, the overall energy input is reduced. While a compressor may be used to introduce gas into the flotation separation system, because the sparging mechanism **42** operates at atmospheric pressure a compressor is not required to overcome the hydrostatic system head. Instead, a simple blower can be used, providing energy and maintenance savings. The energy reduction, of course, implies reduced operating costs. Finally, the smaller separation tank **14** requirements reduce equipment and installation costs. Structural steel requirements are significantly less due to the reduction in tank weight and live load. The space requirement is less than that required for equivalent conventional column flotation separation. Shipping and installation is also simplified since the units can be shipped fully assembled and installed without field welding.

Depending on the operational requirements of the system to which the flotation separation system is installed, FIG. 2 shows how the flotation separation cell **10a** can be designed with multiple sparger units **12a**, in this case three, with an appropriately sized separation tank **14a**. A feed manifold distributor **26a** having distributor pipes **28a** may be used to evenly distribute slurry to each sparger unit **12a**.

In one embodiment of the sparger unit best understood by comparing FIGS. 3 and 4, each sparger unit **12b** comprises a sparger assembly **30b** that allows for the passage of feed slurry to a separation tank (**14** and **14a** in FIGS. 1 and 2). The size of the sparger assembly **30b** is dictated by the size of the flotation separation system in which the sparger unit **12b** is installed and is primarily intended to direct the slurry discharge to an appropriate location within the separation tank **14**. The slurry should be discharged low enough in the separation tank **14** so as to not interfere with froth formation at the top of the separation tank **14**.

06216.0205.03

Slurry is introduced into the sparger unit **12b** through the slurry inlet **38b** and passes through a sparging mechanism **42b**. As has been already discussed, the sparging mechanism **42b** is configured such that slurry flow through it is substantially unrestricted. The effective open area in the sparging mechanism **42b** is substantially the same as the effective open area in the sparger unit **12b** upstream and downstream of the sparging mechanism **42b**. The pressure drop across the sparging mechanism **42b** is about 10 psig or less.

In the embodiments depicted in FIG. 3 and 4, the sparging mechanism **42b** comprises a rotating high-shear element **32b** attached to a rotating shaft **34b** that is powered by an electric motor **36b**. The slurry may be gravity fed if there is enough hydraulic pressure to ensure that the slurry will flow through the flotation separation system. If the hydraulics of the system requires the slurry to be pumped, the slurry need only be pumped with sufficient pressure to ensure passage of the slurry through the flotation separation system. Nevertheless, the sparger unit **12b** will function well over a broad range of slurry flow rates and pressures. Slurry can be introduced into the slurry inlet **38b** of the sparger unit **12b** at a hydraulic pressure of about 25 psig or less. The sparger unit **12b** can operate at a slurry hydraulic pressure of about 2 psig or less.

Gas (typically air) is introduced to the sparger unit **12b** through gas inlets **40b** that are supplied from a gas injection system (discussed in more detail below). The passing slurry flow immediately shears the gas to form bubbles as the gas enters the sparger unit **12b** through the gas inlets **40b**. The gas need not be at a high pressure for effective bubble formation in the slurry. Even at high slurry feed rates, the gas flow and pressure needs only be high enough to allow bubble formation in the slurry.

The bubbles are sheared into smaller bubbles as the slurry passes through the sparging mechanism **42b** and forms a fine bubble dispersion within the slurry. The formation of the bubble dispersion within the sparger unit **12b** exposes a larger volume of slurry to the surface of the

06216.0205.03

bubbles. This increases the incidences of hydrophobic species collision with the bubbles and increases the probability of adhesion of a hydrophobic species to a bubble. In the embodiment depicted in FIGS. 3 and 4, this gas shearing is aided with the rotating high-shear element **32b**. The rotating high-shear element **32b** is intended to shear gas bubbles only and is not intended to agitate or mix the entire slurry volume, therefore, the electric motor **36b** need only be large enough to drive the rotating high-shear element **32b**. This represents a significant energy savings over flotation separation systems that require agitation of the slurry for bubble shearing.

The creation of the bubble dispersion with the sparger unit **12b** exposes the entire volume of slurry to the surface of a bubble. Therefore the bulk of the adhesion of a hydrophobic species to a bubble is likely to occur within the sparger assembly **30b**, in and downstream of the sparging mechanism **42b**.

Once the slurry has passed through sparging mechanism **42b**, the slurry and the bubble dispersion is discharged into a separation tank (**14** and **14a** in FIGS. 1 and 2) through a slurry outlet **51b**. The velocity of slurry discharge is adjusted by changing the location of the distributor plate **44b** using adjustment bolts **46b**.

As shown in the embodiment depicted in FIG. 5, the sparger assembly **30c** can contain opposing static vanes **48c** to increase the shearing of gas bubbles in the sparging mechanism **42c**. It will be appreciated that the rotating high-shear elements **32b** and **32c**, as shown in FIGS. 4 and 5, and the static vanes **48c** shown only in FIG. 5 are for example purposes only and that other configurations of rotating high-shear elements and static vanes are possible and intended to be covered herein.

In the embodiments shown in FIGS. 4 and 5, the gas inlets **40b** and **40c** are situated upstream of the sparging mechanisms **42b** and **42c**. However, the embodiment of sparging mechanism **42d** depicted in FIGS. 6A and 6B has gas inlets **40d** over the length of the sparging mechanism **42d**. The

06216.0205.03

gas inlets **40d** are supplied by gas from an outer sleeve **45d** that connects to the gas injection system (discussed in more detail below) through a hose connection **47d**. The gas inlets **40d** are shown in more detail in FIGS. 6C through 6E and comprise an elastomeric check valve **49d** that prevents the backflow of slurry into the outer sleeve **45d**.

The rotating high shear elements **32b** and **32c** and the static vanes **48c** in the sparging mechanisms **42b** and **42c** serve to break up the bubbles formed at the gas inlets **40b** and **40c** into smaller bubbles to increase the cumulative surface area. Variations of air sparging units are possible in which the gas is introduced to the slurry through the sparging mechanisms such that the bubbles formed are of an appropriate size to form a bubble dispersion.

As can best be understood by comparing the alternate arrangement in FIGS. 7A through 7E, the top of the sparger unit **12e** comprises a gas supply coupling **50e** to the gas injection system (discussed in more detail below). Gas is supplied through a gas supply tube **52e** to the sparging mechanism **42e**. The bottom of the supply tube **52e** ends in a series of slots **56e** that define the length of the sparging mechanism **42e**. In this embodiment, the sparging mechanism **42e** comprises a series of discs **58e** that are stacked up to at least the length of the slots **56e** in the gas supply tube **52e**. Each disc **58e** has a series of grooves **60e** that run from the slots **56e** in the gas supply tube **52e** to the outer edge of the disc **58e**. When the discs **58e** are stacked on top of each other, the grooves **60e** define channels for the gas to mix with the passing slurry. In this embodiment each groove **60e** acts as a gas inlet for the sparger unit **12e**. The number and size of the grooves **60e** and the thickness and the number of the discs **58e** are determined by the particular application. The smaller the grooves **60e**, the smaller the bubbles formed when the passing flow of slurry sparges the gas. The smaller gas bubbles created by the sparging mechanism **42e** in this embodiment are of an appropriate size to form a bubble dispersion. Therefore the grooves **60e** also serve as the high shear

06216.0205.03

element of this embodiment of sparger unit **12e**. This sparger unit **12e** requires even less energy to operate than the embodiments presented earlier.

Nevertheless, the sparging mechanism **42e** is configured such that slurry flow through it is substantially unrestricted. The effective open area in the sparging mechanism **42e** is substantially the same as the effective open area in the sparger unit **12e** upstream and downstream of the sparging mechanism **42e**. The pressure drop across the sparging mechanism **42e** is about 10 psig or less.

The sparger units **12e** can be easily disconnected from the gas injection system (discussed in more detail below) and water, gas, or another cleaning agent can be forced through the grooves **60e** to facilitate cleaning of the sparging mechanism **42e**. The discs **58e** may be made from metal, plastic, polyurethane, ceramics, or any other material that would be appropriate for the particular application. While the discs **58e** depicted in FIGS. 7A through 7E have grooves **60e** on only one side, FIG. 8 shows a disc **58f** having grooves **60f** on both sides.

The sparger units **12g** shown in FIGS. 9A through 9C are a variation of the sparger unit **12e** of FIG. 7A. This embodiment incorporates a cleaning mechanism for the sparging mechanisms **42g**. As can be best understood by comparing FIGS. 9A through 9C, the sparger unit **12g** includes an inner gas supply tube **52g** connected by a gas supply coupling **50g** to the gas injection system (discussed in more detail below). A cleaning fluid coupling **53g** allows for the introduction of a cleaning fluid into the sparger unit **12g**. The fluid could be water, compressed gas, or other fluid that could be fed at high pressure to clear debris or clean out the grooves on the discs **58g** during routine maintenance or as needed.

The embodiment of sparger unit **12h** shown in FIG. 10 shows the sparging mechanism **42h** comprising a high frequency displacement device **54h**. In this embodiment gas is introduced to the sparger unit **12h** similar to the embodiment shown earlier, but other gas injection mechanisms are possible. The high frequency displacement device **54h** generates a high frequency vibration at the

06216.0205.03

high shear element **32h** that sparges bubbles formed by the gas inlets (not shown) as the bubbles pass the sparging mechanism **42h**. This vibration shears the bubbles to create the fine bubble dispersion in the slurry. Nevertheless, the sparging mechanism **42h** is configured such that slurry flow through it is substantially unrestricted. The effective open area in the sparging mechanism **42h** is substantially the same as the effective open area in the sparger unit **12h** upstream and downstream of the sparging mechanism **42h**. The pressure drop across the sparging mechanism **42h** is about 10 psig or less.

As shown in FIG. 11, other embodiments of sparger units **12i** are possible in which the sparging mechanism **42i** extends across the length of the sparger assembly **30i**. These embodiments function similarly to the sparger unit **12b** shown and described in FIG. 4 above, however any of the other embodiments described above would work equally well. The sparging mechanism **42i** shown in FIG. 11 comprises a series of rotating high shear elements **32i** that serve to further break up and shear introduced gas into fine bubbles. In this embodiment, the blades of the high shear elements **32i** have openings cut into them to further shear the bubbles. The stacked rotating high shear elements **32i** increase the amount of sparging each unit volume of slurry is exposed to as it moves through the sparger unit **12i**. As with the embodiments discussed above, the energy input into the sparger unit **12i** is for shearing introduced gas into a fine bubble dispersion and not for agitating the slurry. The sparger unit **12i** could also incorporate static vanes as shown for example in FIG. 5 to increase the shearing of gas bubbles in the sparging mechanism. The embodiment shown in FIG. 11 shows the outlets **51i** from the sparger unit **12i** as holes cut into the side of the sparger assembly **30i**.

Regardless of the embodiment of sparger unit **12j** used, the operation of the flotation separation system is demonstrated in the flotation separation cell **10j** depicted in FIG. 12. The flotation separation cell **10j** shows three sparger units **12j**, but the operation described is applicable

06216.0205.03

to any number of sparger units **12j**. A flotation separation cell having only one sparger unit (for example as shown in FIG. 1) would not require a feed manifold distributor as shown in FIG. 12.

Slurry is fed to the feed manifold distributor **26j** from upstream operations in which the flotation separation cell **10j** is installed. As has already been discussed, the slurry may be pumped under pressure into the sparger unit if the system hydraulics require, but this need only be sufficient to provide enough hydraulic pressure for the slurry to flow through the flotation separation cell **10j**. Slurry can be introduced into the flotation separation cell **10j** at the slurry inlet **38j** of the sparger unit **12j** at a hydraulic pressure of about 25 psig or less. The feed manifold distributor **26j** evenly distributes slurry to the slurry inlets **38j** of the sparger units **12j** through distributor pipes **28j**. The pressure drop across the sparging mechanisms of the sparger units **12j** is about 10 psig or less.

Gas, typically air, is supplied to the sparger units **12j** from the gas injection system **62j**. As discussed earlier, gas introduction pressure need only be high enough to allow bubbles to form in the slurry. The gas injection system **62j** consists of a pressure regulator **64j**, a gas flow meter **66j**, a flow regulating valve **70j**, and a gas manifold distributor **72j**. The gas manifold distributor **72j** connects the gas injection system to the sparger units **12j**. A low-pressure gas blower (not shown) would preferably supply gas to the gas injection system **62j**. Alternatively, compressed gas tanks (not shown) or gas compressors (not shown) can be employed.

The operation of sparger units **12j** is as previously described. The slurry and the bubble dispersion are discharged into the separation tank **14j**, which allows for the separation of the floatable and non-floatable hydrophobic species. A froth of bubbles with adhered floatable hydrophobic species forms above the slurry at the top the separation tank **14j**. The froth can be removed from the top of the separation tank for further processing. In one embodiment, the froth overflows the separation tank into a product launder **16j**. The froth overflow is discharged from the product launder **16j** through the overflow drain **22j** for further processing.

06216.0205.03

Non-floatable hydrophobic species, heavier particles that do not adhere to the froth, and any hydrophobic species that for whatever reason do not adhere to the froth fall to the bottom of the separation tank **14j** and are drained through the underflow removal port **18j** for further processing. The rate of underflow discharge is controlled through a control valve **74j** that is actuated based on a signal provided by a process controller **76j**. The output of the process controller **76j** is proportional to an input signal derived from a pressure sensor **78j** located on the side of the separation tank **14j**. Alternatively, various other level control systems can be employed such as pumps, sand gates, and overflow weir systems.

The froth at the top of the separation tank is washed with the froth washing system **20j**. Water or any other cleaning liquid used for froth washing is controlled by the froth washing control system **80j**. In the froth washing system **20j**, clean water is evenly distributed across the top of the froth using a perforated wash pan. Alternatively, the froth washing system **20j** can comprise rings of perforated pipe (not shown). The flow of wash water is controlled using a flow meter **82j** and a flow control valve **84j**.

A pilot scale flotation separation system similar to the flotation separation cell depicted in FIG. 1 is currently in operation. The pilot flotation separation cell comprises a separation tank that is 48 inches in diameter and about 60 inches deep and has a single sparger unit that is about 4 inches in diameter. The sparger unit processes coal slurry at the rate of about 600 gpm. The sparging mechanism is similar to the embodiment depicted in FIG. 4. The high shear element of the sparger unit rotates at about 1,200 rpm. Gas is introduced at the gas inlets at about 60 scfm. Slurry enters the sparging mechanism by gravity and has been measured at the sparging mechanism to have a hydraulic pressure of less than 1 psig. During normal operating conditions, slurry fills the separation tank up to 3 feet from the bottom with froth filling an additional 2 feet above the slurry. The froth is

06216.0205.03

washed with clean water using clean water sprayed over the top of the froth through an arrangement of perforated pipes at a rate of up to 60 gpm.

The flotation response of several coal types were investigated including the Amburgy, Hazard No. 4, Red Ash, Gilbert and Pocahontas No. 3 seams. For the Amburgy and Hazard No. 4 seams (Figure 5), the ash content of the flotation feed averaged 52%, by weight. Combustible recovery ranged from 30% to 78% depending on operating parameters. The average combustible recovery for a single-stage of treatment was approximately 60% with a product ash content of 6%. Similarly, an average combustible recovery of between 40% and 50% was achievable while treating Red Ash, Gilbert, or Pocahontas No. 3 coal seams. For these coals, the product ash averaged less than 4% by weight. The lower feed ash (i.e., 18%) for these seams resulted in a slightly lower range of combustible recovery. This finding is not unexpected given that as the feed ash decreases, the amount of floatable coal increases for a given volume flow and retention time.

While hydrophobic species adhesion to the bubble dispersion in the sparger units **12j** allows for a high recovery of hydrophobic species in the slurry, not all of the hydrophobic species in the slurry will adhere to a bubble. Furthermore, there is a reduction in bubble surface area at the interface of the froth and the slurry in the separation tank **14j** that leads some adhered hydrophobic species to fall off and be lost to the underflow nozzle **18j**. As has been already discussed, the flotation separation system described herein requires a smaller separation tank size than conventional flotation separation systems. As shown in FIGS. 13 and 14, this allows for several flotation separation cells **10j** to be easily combined in-series to negate the effects of mixing and hydrophobic species bypass of the bubble dispersion.

The fundamental principle favoring a tank-in-series approach is simple and well known: for an equivalent retention time, a series of perfectly mixed tanks will provide a higher recovery than a single cell. This point is illustrated by the following equation:

06216.0205.03

$$R = 1 - \left(\frac{N}{N + k\tau} \right)^N \quad [3]$$

where the change in recovery, R , is a function of the number of perfect mixers (N) for a system with a constant process rate (k) and retention time (τ). As shown in FIG. 15, increasing the number of mixers in series, at a constant value of $k\tau$, results in an increase in recovery. For example, for a $k\tau$ value of 4, changing from one perfectly mixed tank to four cells in series results in an increased recovery of nearly 15%.

This concept can be understood by examining the basic operation of a conventional flotation cell. Each cell contains a mixing element that is used to disperse air and maintain the solids in suspension. As a result, each cell behaves “almost” as a single perfectly mixed tank. By definition, a perfectly mixed tank has an equal concentration of material at any location in the system. Therefore, a portion of the feed material has an opportunity to immediately short circuit to the tailings discharge point. In a system using a single large cell, this would imply a loss in recovery. However, by discharging to a second tank, another opportunity exists to collect the floatable material. Likewise, this is also true with the third and fourth cell in the series. Of course, at some point, the law of diminishing returns applies. In conventional flotation systems, this is typically after four or five cells in series. However, the recovery gain with each cell requires additional energy.

Based on the same principle, the in-series arrangements shown for example in FIGS. 13 and 14 reduce the inadvertent bypass of feed slurry from individual flotation separation cells **10j**. In such modular in-series arrangements, the slurry that leaves through the underflow nozzle **18j** of one separation tank **14j** is redirected to the sparger units **12j** of the next flotation separation cell **10j**. This arrangement increases the particulate recovery from a slurry stream. The flotation separation cells **10j** can be placed in a modular vertical arrangement (as in FIG 13), a staggered horizontal arrangement (as in FIG 14), or any arrangement that allows for a sufficient hydraulic pressure to

06216.0205.03

convey the slurry from cell to cell. If such a configuration is not possible in the particular application, the slurry could be pumped to each subsequent cell in the series. The number of required flotation separation cells **10j** will be dependent on the specific application.

In any of the embodiments herein, it is also possible to divert a portion of the slurry discharge from the underflow removal port **18** or the overflow drain **22** back to the initial sparger unit **12** (or the feed manifold distributor **26a** in flotation separation systems with more than one sparger unit **12a**). This would serve to recycle any chemical additives used to promote frothing and would reduce the materials cost of operation. Similarly, in the embodiments shown in FIGS. 13 and 14, a portion of the discharge from the underflow removal port **18j** or the overflow drain (not shown) from the last flotation separation cell **10j** can be diverted back to the feed manifold distributor **26j** of the first flotation separation cell **10j**.

The energy requirements of the flotation separation systems described herein are orders of magnitude lower than conventional flotation separation systems, column flotation separation systems, and packed column flotation separation systems for processing a similar amount of slurry with comparable recovery results. A conventional flotation separation system that processes 3,000 gpm of coal slurry may typically comprise 6-8 separation tanks in series, with each separation tank containing a 20-30 HP motor to turn impellers to mix the slurry in the tanks, for a total of about 200 HP for mechanical agitation. Such a conventional system would require an additional 150 HP to power the air blower system for sparging gas. A typical column flotation separation system that processes 3,000 gpm of coal slurry requires slurry recirculation pumps that could require around 200 HP to operate. An additional 200 HP would be required to operate the air compressors for sparging bubbles. A packed column flotation separation systems of similar 3,000 gpm capacity typically would have similar requirements to a typical column flotation system with about 200 HP for recirculation pumps and about 200 HP for air compressors.

06216.0205.03

In contrast, a flotation separation system as described herein for processing 3,000 gpm of coal slurry, comprising three flotation separation cells in series, each cell having a single sparger unit with sparging mechanisms that comprise a series of rotating high shear elements (similar to those shown in FIG. 11) would require significantly less energy. The energy required to power each sparger unit in such a system would be around 20 HP for a total of 60 HP for all three sparger units. The energy required by the gas supply system would be about 70 HP for all three sparger units. Each separation tank in such a configuration would be about 11 feet in diameter and about 6 feet deep. This represents a significant savings in energy consumption and material requirements.

The small footprint required for the flotation separation cell **10j** suggests that it can be used to relieve the loading on existing conventional flotation cells **85j** as shown for example in FIG. 16A. In such an arrangement, slurry that has been processed in the flotation separation cell **10j** and discharged through the underflow removal port **18j** is fed to the inlet **86j** of a conventional flotation cell **85j**. Collected froth from the flotation separation cell's **10j** overflow launder **16j** and overflow drain **22j** is combined with product collected from the conventional flotation cell's **85j** discharge **87j**. As a significant portion of the hydrophobic species in the slurry has been removed by the flotation separation cell **10j**, the reduced loading to the conventional flotation cell **85j** leads to an overall increase in its performance and an improved overall recovery percentage of the hydrophobic species from flotation separation.

Similarly, as shown in FIG. 16B, a flotation separation cell **10j** can be located upstream of an existing column flotation cell **88j**. In such an arrangement, slurry that has been processed in the flotation separation cell **10j** and discharged through the underflow removal port **18j** is fed to the inlet **89j** of a conventional column flotation cell **88j**. Collected froth from the flotation separation cell's **10j** overflow launder **16j** and overflow drain **22j** is combined with product collected from the column flotation cell's **88j** discharge **91j**. As a significant portion of the hydrophobic species in the

06216.0205.03

slurry has been removed by the flotation separation cell **10j**, the reduced loading to the column flotation cell **88j** leads to an overall increase in its performance and an improved overall recovery percentage of the hydrophobic species from flotation separation.

The pilot scale test indicated that there would be additional benefit to the flotation separation systems disclosed herein if a center well **90k** were to be incorporated in the separation tank **14k**, as shown in FIG. 17A. As can be best understood by comparing FIGS. 17A and 17B, the center well **90k** fits around the outside of the sparger unit **12k** and comprises a tube that runs the height of the separation tank **14k**. Outlets **92k** near the bottom of the center well **90k** allow for the slurry discharged from the sparger unit **12k** to enter the separation tank **14k**.

The purpose of the center well **90k** is to ensure that the sparger assembly within the center well **90k** remains submerged below the liquid level and to aid in efficient bubble formation and promote efficient bubble/particle interaction. At low flows, the center well **90k** liquid level will be at the same level as that of the surrounding separation tank **14k**. However, at higher flows, the level within the center well **90k** will be higher than that of the surrounding separation tank **14k**. The higher level ensures that there is no chance for air to coalesce within the sparger unit **12k** and ultimately reduces burping and inefficient contacting within the sparger unit **12k**. The liquid level in the center well **90k** can be determined by reading a low-pressure pressure gauge (not shown) that is installed on the slurry inlet **38k**. In order to ensure that the center well **90k** stays full, the center well **90k** must be engineered such that it flushes just slightly slower than it fills. Only a positive pressure is required to indicate that the center well **90k** is full.

Level control in the center well can be maintained in several ways as shown in FIGS. 18A through 18C. As shown in FIG 18A, the center well **90l** is constructed such that the size of the outlets **92l** can be continuously adjusted. A low-pressure gauge **94l** installed at the slurry inlet **38l** monitors the pressure in sparger unit **12l**. A PID control loop **96l** adjusts the outlet **92l** size in

06216.0205.03

response to changes in the pressure readings - an increase in pressure above a preset limit will trigger the PID control loop **96l** to increase the outlet **92l** size to allow more slurry to leave the sparger unit **12l** and the center well **90l**; a decrease in pressure below a preset limit will trigger the PID control loop **96l** to decrease the outlet **92l** size which will retain more slurry in the center well **90l** and keep the sparger unit **12l** submerged. It was contemplated that direct level control of the level of the separation tank **14l** could be performed by using a PID process controller to throttle the outflow from the underflow nozzle **18l** based on pressure readings in the separation tank **14l**. While this method will ensure a consistent level in the separation tank **14l**, it would not ensure that there is sufficient pressure within the center well **90l**.

A simpler control scheme is shown in FIG. 18B that negates the need for a control mechanism to be placed within the separation tank **14m**. In essence, the center well **90m** level is maintained by controlling the flow from the inflow to the flotation separation system by automating a make-up valve **98m** through a PID control loop **96m** such that a low pressure reading from the low-pressure pressure gauge **94m** triggers additional liquid, and hence flow, to be routed to the separation cell **10m**.

This method can be easily applied to a series of separation tanks **10n**, as shown in FIG 18C. For the next cell in series for flotation separation systems that comprise a series of flotation separation cells **10n**, a second PID control loop **100n** controls the underflow nozzle **18n** of the previous separation cell **10n** in the series. These embodiments require only automation of the underflow nozzle **18n** as per accepted industrial practice.

Other designs of flotation separation cells are also possible. FIG. 19 shows a flotation separation cell **10o** in which the slurry enters the sparger units **12o** from underneath the separation tank **14o**. A feed manifold distributor **26o** distributes slurry to each sparger unit **12o** through distributor pipes **28o** to the sparging mechanisms **42o**. Gas is supplied to the sparger units as

06216.0205.03

described above. The electric motors **36o** that power the rotating high-shear element (not shown) via rotating shafts **34o** are located above the separation tank **14o**. The electric motors **36o** are supported in place with a support ring **90o**. Slurry passes up through the sparging mechanism **42o** and into the separation tank **14o**.

FIG. 20 shows an embodiment of a flotation separation cell **10p** in which the sparger units **12p** are located on the side of the separation tank **14p**. In this embodiment the feed manifold distributor **26p** is shown feeding the sparger units **12p** from underneath the separation tank **14p**. The feed manifold distributor **26p** can also be located above the separation tank **14p** as shown in earlier embodiments.

The underflow removal port **18q** does not need to be located at the bottom of the flotation separation cell **10q**. The embodiment shown in FIG 21 shows how the underflow removal port **18q** can remove slurry from the side of the separation tank **14q**. The underflow removal port **18q** has a right angle bend directed towards the bottom of the separation tank **14q** to allow for a uniform withdrawal of slurry from the bottom of the separation tank **14q**. The slurry can be withdrawn from the underflow removal port **18q** by gravity as a drain or with a pump, sand gates, an overflow weir system, or any other appropriate mechanism.

This invention has been described with reference to several preferred embodiments. Many modifications and alterations will occur to others upon reading and understanding the preceding specification. It is intended that the invention be construed as including all such alterations and modifications in so far as they come within the scope of the appended claims or the equivalents of these claims.

Claims:

1. A sparger unit for forming bubbles in a slurry in a flotation separation system, the sparger unit connected to a flotation separation cell, the slurry including a hydrophobic species which can adhere to gas bubbles formed in the slurry, said sparger unit comprising:

a slurry inlet for receiving slurry and a gas inlet to receive gas with at least enough pressure to allow bubbles to form in the slurry within said sparger unit;

a sparging mechanism constructed to disperse gas bubbles within the slurry and having a high shear element to sparge the gas bubbles to form a bubble dispersion so as to cause adhesion of the hydrophobic species to the gas bubbles substantially within said sparger unit while causing a pressure drop of about 10 psig or less across said sparging mechanism; and

a slurry outlet to discharge the slurry and the bubble dispersion from the sparger unit.

2. The sparger unit of claim 1 in which the pressure drop across said sparging mechanism is about 1 psig or less.

3. The sparger unit of claim 1 in which the slurry is introduced to the sparger unit at a hydraulic pressure of about 25 psig or less.

4. The sparger unit of claim 1 in which the slurry is introduced to the sparger unit at a hydraulic pressure of about 2 psig or less.

5. The sparger unit of claim 1 in which the slurry is introduced to the sparger unit at a hydraulic pressure determined by gravity flow.

6. The sparger unit of claim 1 in which said high-shear element comprises a rotating high-shear element.

7. The sparger unit of claim 1 in which said high-shear element comprises a series of rotating high-shear elements.

8. The sparger unit of claim 1 in which said high-shear element comprises rotating and static high-shear elements.

9. The sparger unit of claim 1, wherein:
said gas inlet discharges gas into the slurry through said sparging mechanism;

and

said high-shear element comprises a series of grooved discs pressed together to form channels, and gas passes through said channels to reach the slurry.

10. The sparger unit of claim 1, wherein:
said gas inlet discharges gas into the slurry through said sparging mechanism;

and

said high-shear element comprises a series of grooved discs pressed together to form channels, said grooved discs having grooves on both sides, and gas passes through said channels to reach the slurry.

11. The sparger unit of claim 1, wherein:
said gas inlet discharges gas into the slurry through said sparging mechanism;

and

said high-shear element comprises a series of grooved discs pressed together to form channels, said grooved discs having grooves on one side, and gas passes through said channels to reach the slurry.

12. The sparger unit of claim 1 in which said high-shear element comprises a high frequency displacement device.

13. The sparger unit of claim 1 further comprising adjustable distributor plates at about said slurry outlet for adjusting the velocity of slurry and bubble dispersion discharge from said slurry outlet.

14. The sparger unit of claim 1 in which said gas inlet receives air from one of the group consisting of a gas compressor, a compressed gas tank, and a gas blower.

15. The sparger unit of claim 1 in which said sparger unit is surrounded by a center well.

16. The sparger unit of claim 1, wherein:
a center well surrounds said sparger unit; and
a level control mechanism maintains the liquid level in said center well.

17. The sparger unit of claim 1, wherein:
a center well surrounds said sparger unit;
a level control mechanism maintains the liquid level in said center well; and
said level control mechanism includes adjustable outlets in said center well.

18. The sparger unit of claim 1, wherein:
a center well surrounds said sparger unit;
a level control mechanism maintains the liquid level in said center well; and
said level control mechanism includes a control loop for regulating additional flow to and from the flotation separation system.

19. The sparger unit of any of claims 1 through 18 installed in a flotation separation system which comprises:

a flotation separation cell, said flotation separation cell including the sparger unit and a separation tank.

20. The sparger unit of claim 19 further comprising more than one said flotation separation cell in series.

21. The sparger unit of claim 19 further comprising:
more than one said flotation separation cell in series;
the slurry separated from the froth in each said separation tank in each said flotation separation cell directed to the slurry inlet of each subsequent said flotation separation cell; and

the slurry separated from the froth in said separation tank of the last said flotation separation cell in series directed outside of the flotation separation system.

22. The sparger unit of claim 19 further comprising:
more than one said flotation separation cell in series;
the slurry separated from the froth in each said separation tank in each said flotation separation cell directed to the slurry inlet of each subsequent said flotation separation cell; and

a portion of the slurry separated from the froth in said separation tank in the last said flotation separation cell in series directed to the first said flotation separation cell in said series and the remainder of the slurry separated from the froth in said separation tank in the last said flotation separation cell in series directed outside of the flotation separation system.

23. The sparger unit of claim 19 in which said flotation separation cell further comprises an overflow launder to capture froth overflow from said separation tank.

24. The sparger unit of claim 19 in which said flotation separation cell further comprises an underflow removal port.

25. The sparger unit of claim 19 in which said flotation separation cell further comprises an underflow removal port, said underflow removal port further is a drain, a pump, sand gates, or an overflow weir system.

26. The sparger unit of claim 19 in which said gas inlet receives air from one of the group consisting of a gas compressor, a compressed gas tank, and a gas blower.

27. The sparger unit of claim 19 in which said flotation separation cell comprises more than one sparger unit for introducing slurry at more than one location within said separation tank.

28. The sparger unit of claim 19 in which said flotation separation cell further comprises:

more than one sparger unit for introducing slurry at more than one location within said separation tank; and

a feed manifold distributor for distributing slurry to each said sparger unit.

29. A method of flotation separation for partitioning a slurry in a flotation separation system, the flotation separation system including a flotation separation cell, the flotation separation cell including a sparger unit and a separation tank, the sparger unit including a sparging mechanism, the slurry including a hydrophobic species which

can adhere to gas bubbles formed in the slurry, said flotation separation method comprising:

introducing a slurry into a sparging unit;

introducing gas into the slurry in the sparging unit with at least enough pressure to form bubbles in the slurry;

sparging the gas in the slurry into a bubble dispersion with the sparging mechanism at a pressure drop across the sparging mechanism of about 10 psig or less;

and

discharging the slurry and the bubble dispersion from the sparger unit to the separation tank to allow the bubble dispersion to form a froth at the top of the separation tank.

30. The method of claim 29 further comprising passing the slurry through more than one flotation separation cell in series.

31. The method of claim 29 further comprising:

passing the slurry through more than one flotation separation cell in series; and

separating the slurry from the froth in the separation tank of the last flotation separation cell in series and directing the slurry outside of the flotation separation system.

32. The method of claim 29 further comprising:

passing the slurry through more than one flotation separation cell in series;

separating a portion of the slurry from the froth in the separation tank of the last flotation separation cell in series and directing the portion of the slurry to the first separation tank in series; and

directing the remaining slurry outside of the flotation separation system.

33. The method of claim 29 further comprising introducing slurry and bubble dispersion into the separation tank at several locations within the separation tank.

34. The method of claim 29 in which the pressure drop across the sparging mechanism is about 1 psig or less.

35. The method of claim 29 in which the slurry is introduced to the sparger unit at a hydraulic pressure of about 25 psig or less.

36. The method of claim 29 in which the slurry is introduced to the sparger unit at a hydraulic pressure of about 2 psig or less.

37. A sparger unit for forming bubbles in a slurry in a flotation separation system, the sparger unit connected to a flotation separation cell, the slurry including a hydrophobic species which can adhere to gas bubbles formed in the slurry, said sparger unit comprising:

a slurry inlet for receiving slurry and a gas inlet to receive gas with at least enough pressure to allow bubbles to form in the slurry within said sparger unit;

a sparging means for dispersing and sparging gas bubbles within the slurry to form a bubble dispersion so as to cause adhesion of the hydrophobic species to the gas bubbles substantially within said sparger unit while causing a pressure drop of about 10 psig or less across said sparging means; and

a slurry outlet to discharge the slurry and the bubble dispersion from the sparger unit.

38. The sparger unit of claim 37 in which the pressure drop across said sparging means is about 1 psig or less.

39. The sparger unit of claim 37 in which the slurry is introduced to the sparger unit at a hydraulic pressure of about 25 psig or less.

40. The sparger unit of claim 37 in which the slurry is introduced to the sparger unit at a hydraulic pressure of about 2 psig or less.

41. The sparger unit of claim 37 in which the slurry is introduced to the sparger unit at a hydraulic pressure determined by gravity flow.

42. The sparger unit of claim 37 further comprising adjustable distributor plates at about said slurry outlet for adjusting the velocity of slurry and bubble dispersion discharge from said slurry outlet.

43. The sparger unit of claim 37 in which said sparger unit is surrounded by a center well.

44. The sparger unit of claim 37, wherein:
said sparger unit is surrounded by a center well; and
a level control means maintains the liquid level in said center well.

1/24

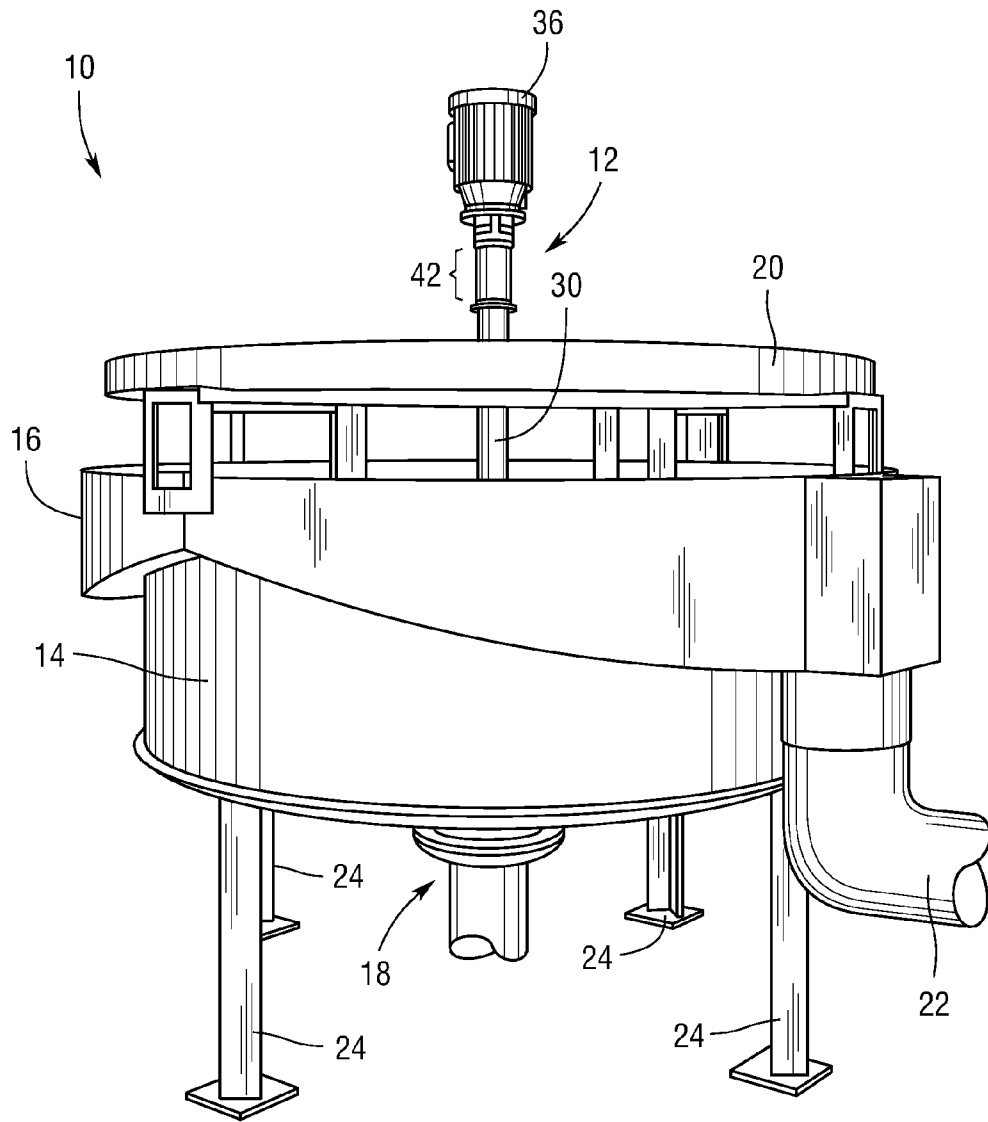

Fig.1

2/24

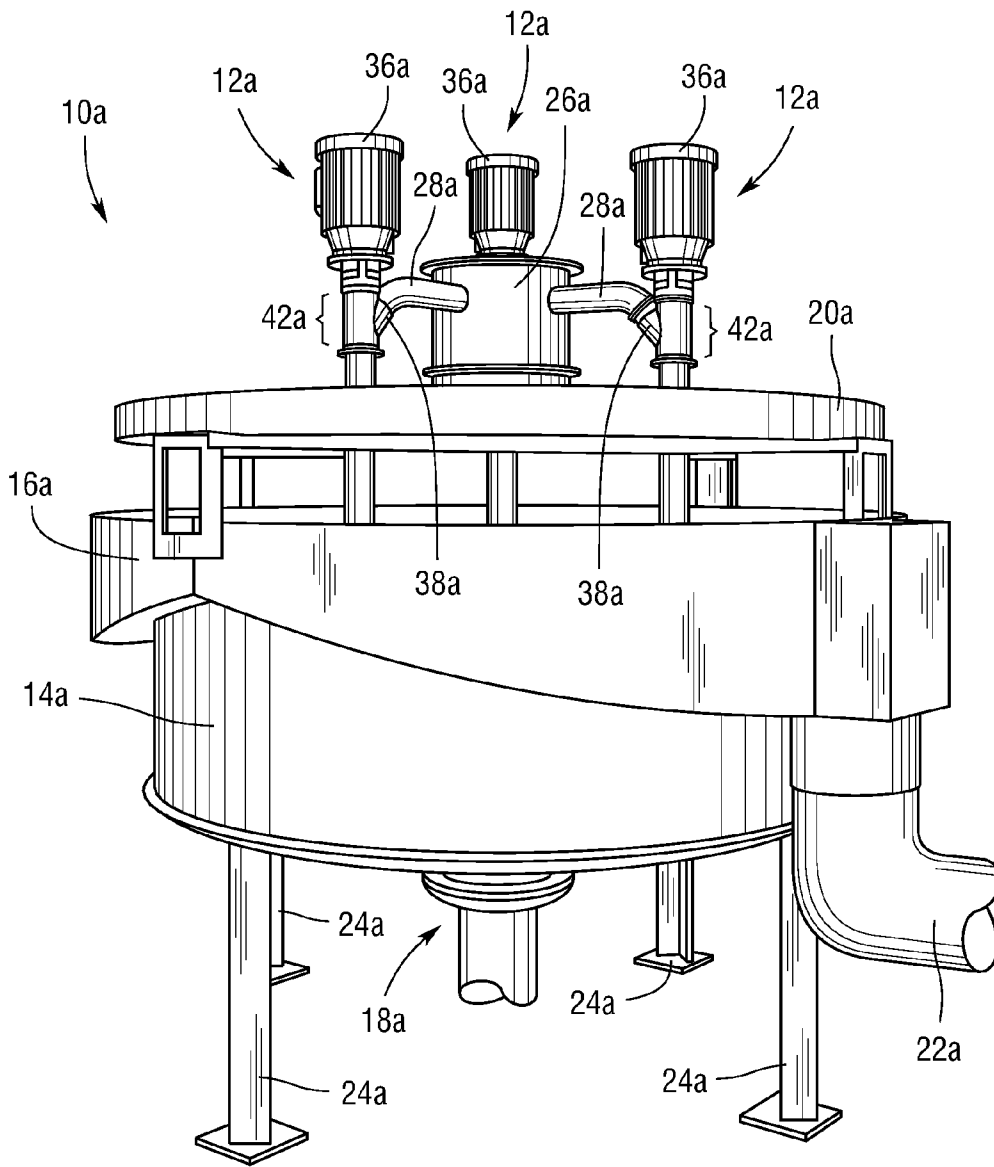

Fig.2

3/24

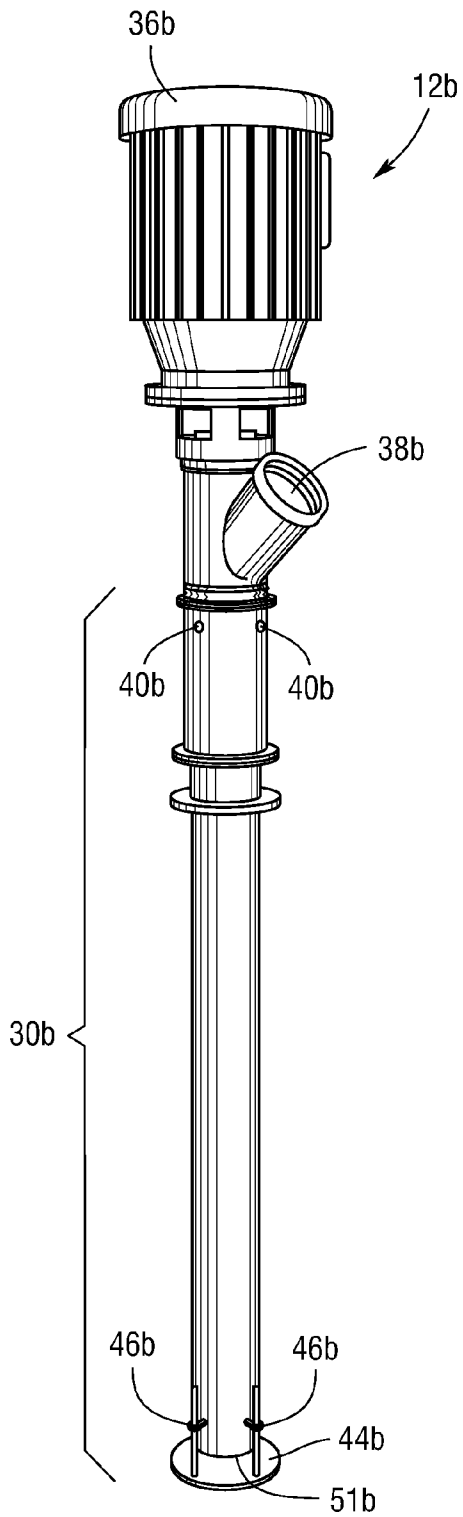

Fig. 3

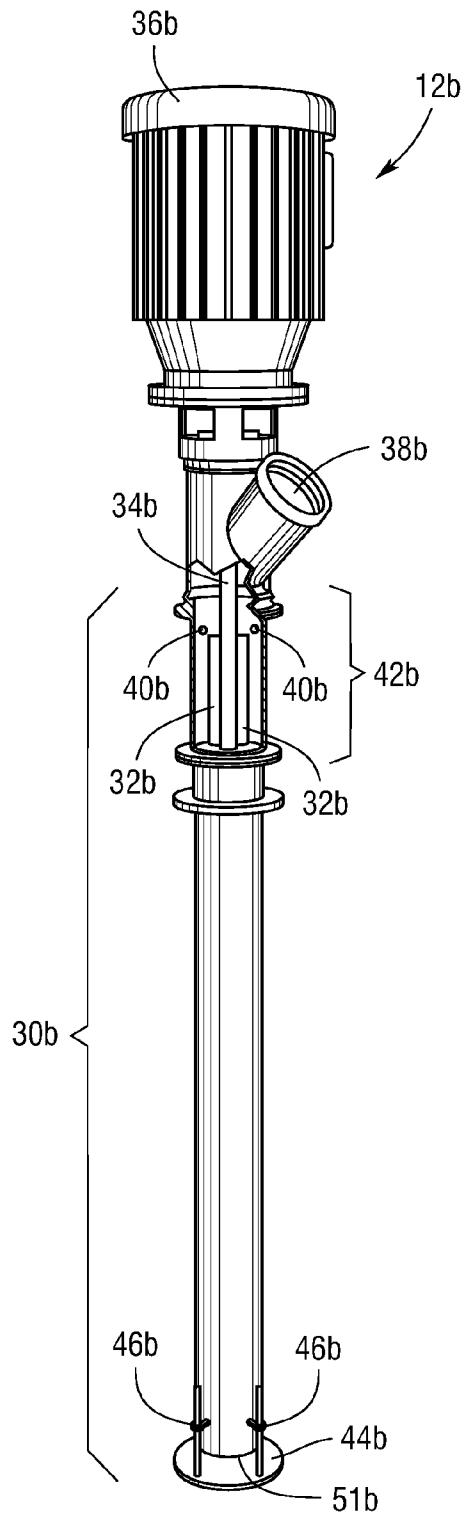

Fig. 4

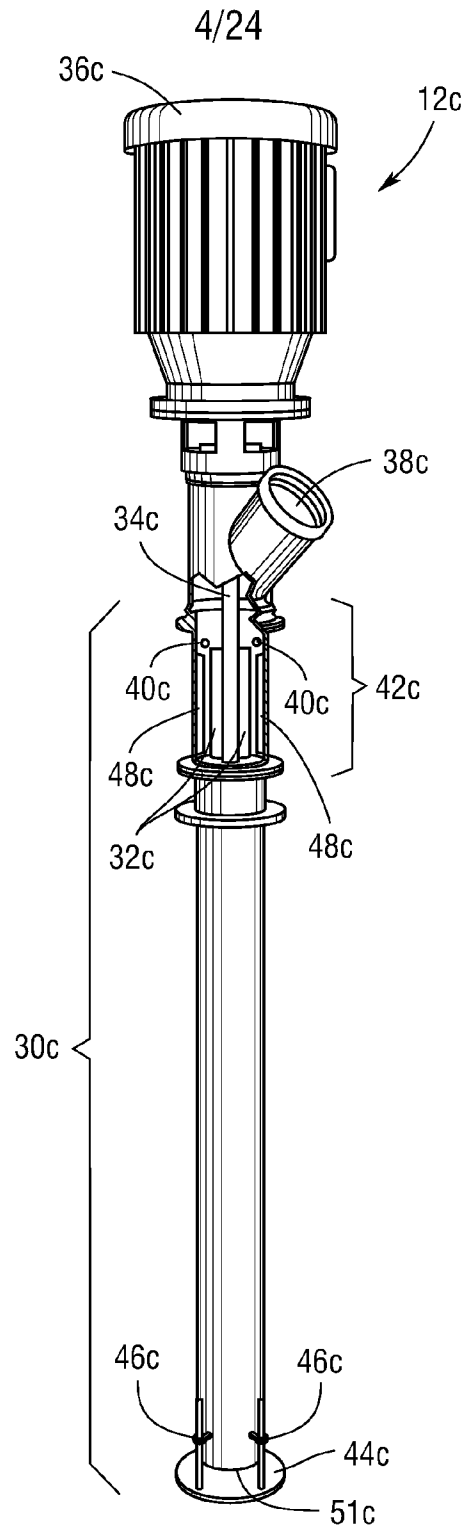

Fig.5

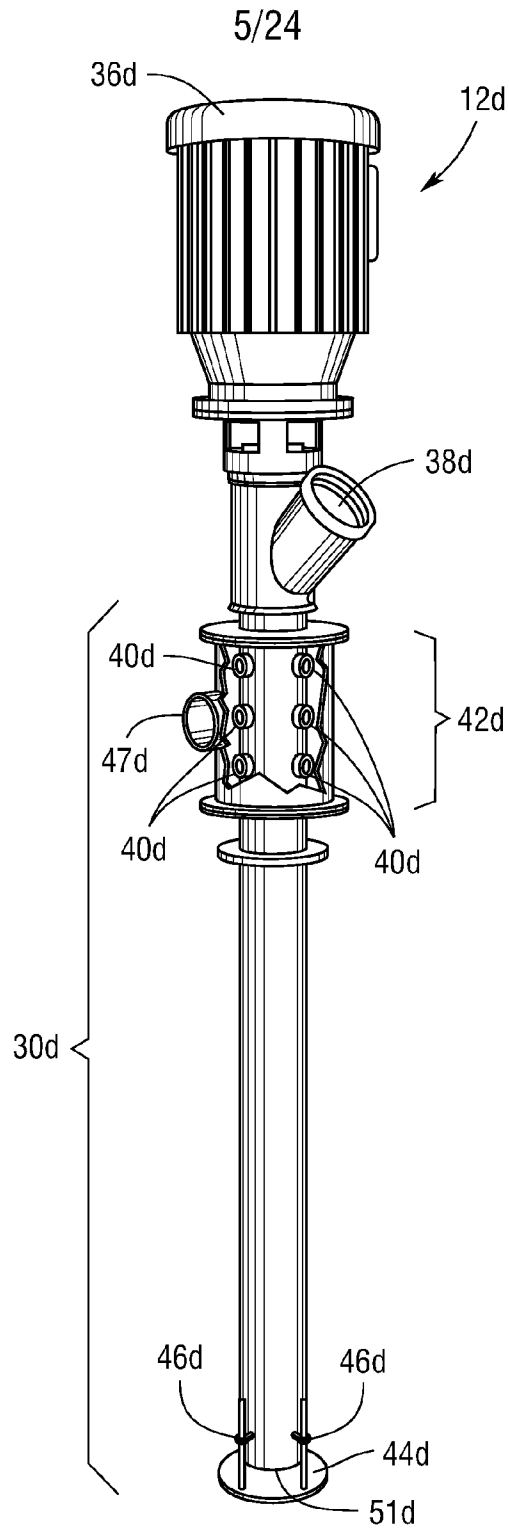

Fig.6A

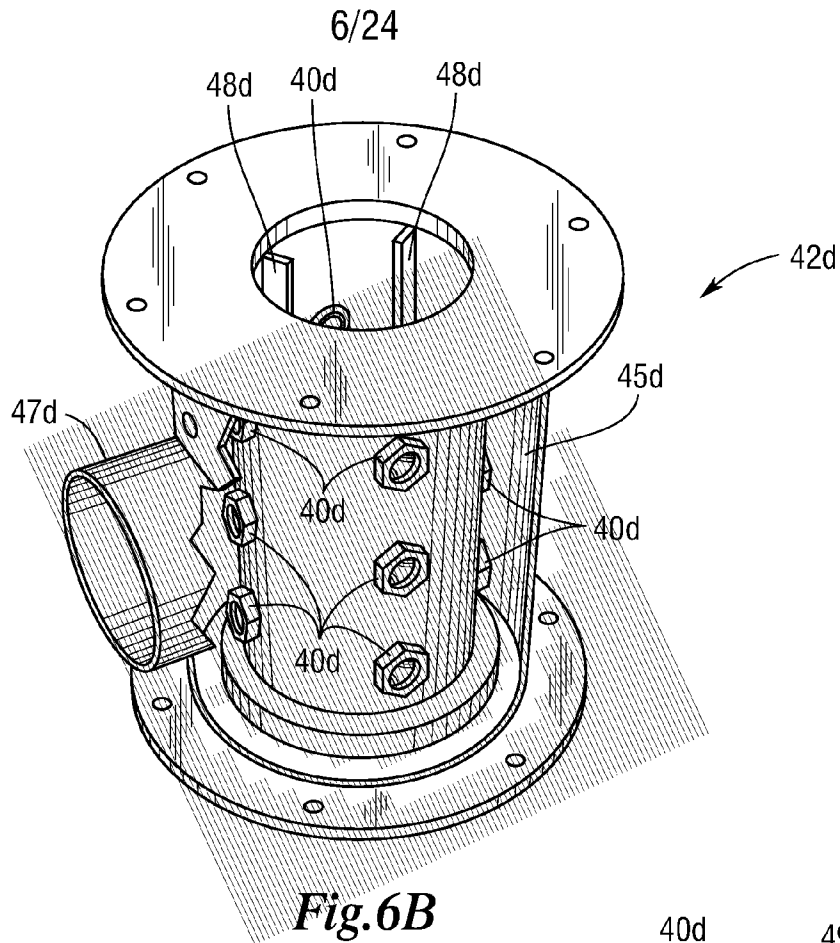

Fig. 6B

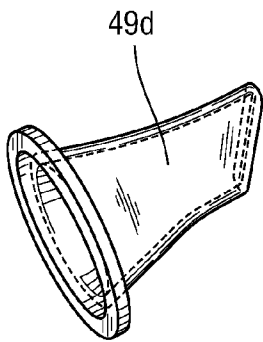

Fig. 6C

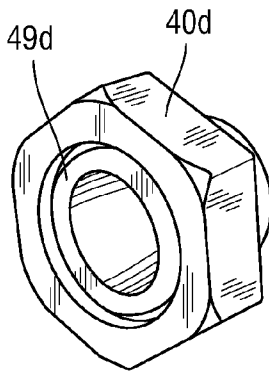

Fig. 6D

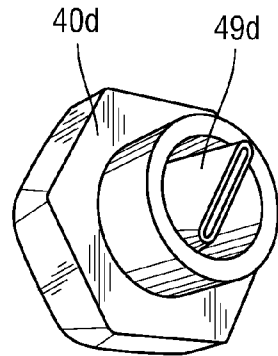

Fig. 6E

7/24

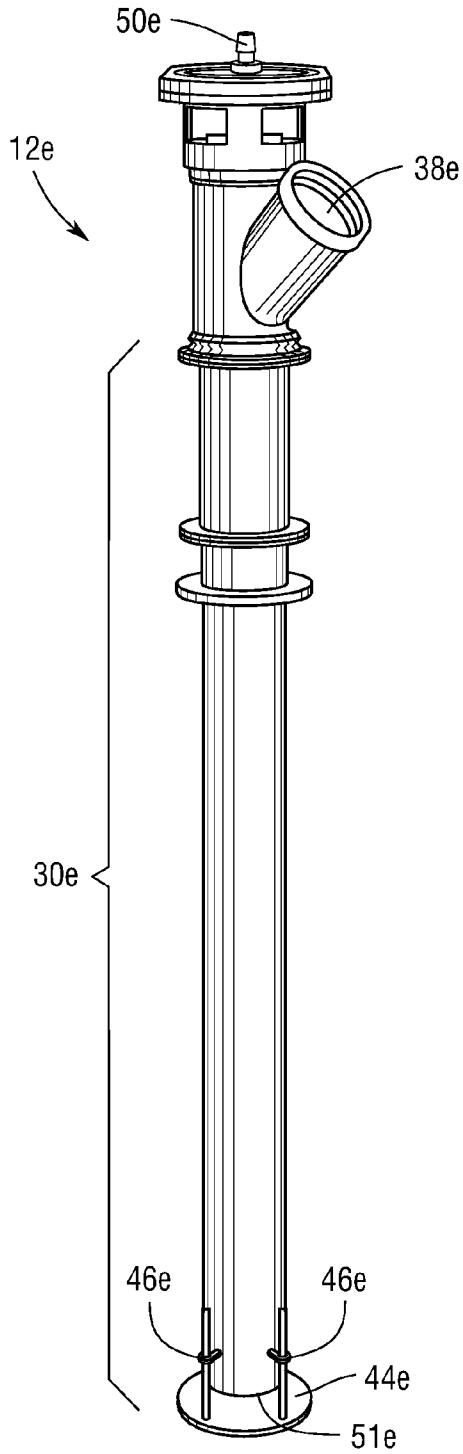

Fig. 7A

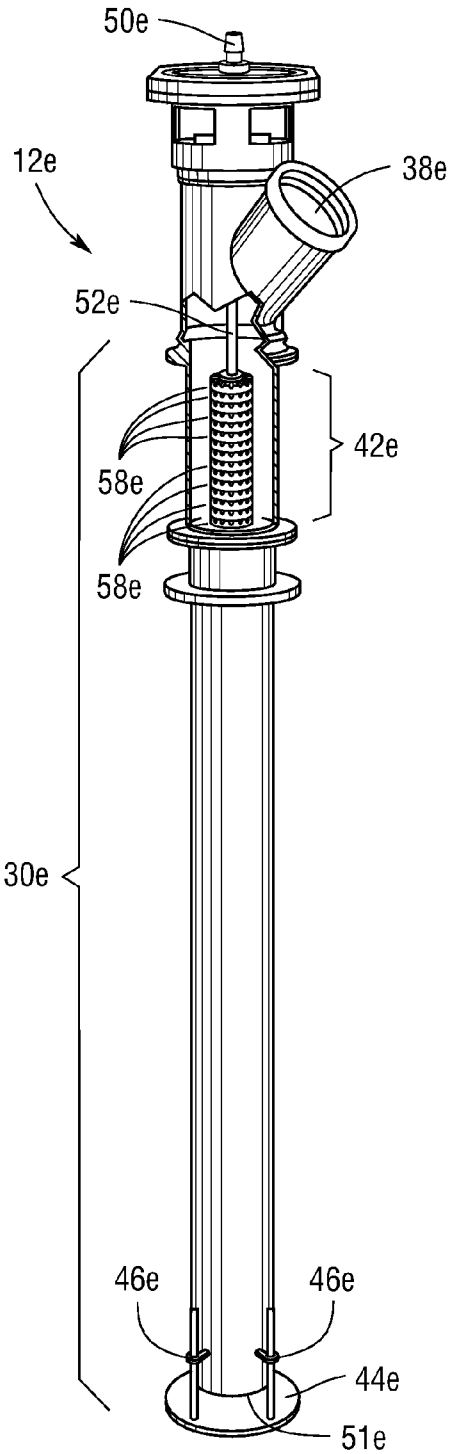

Fig. 7B

8/24

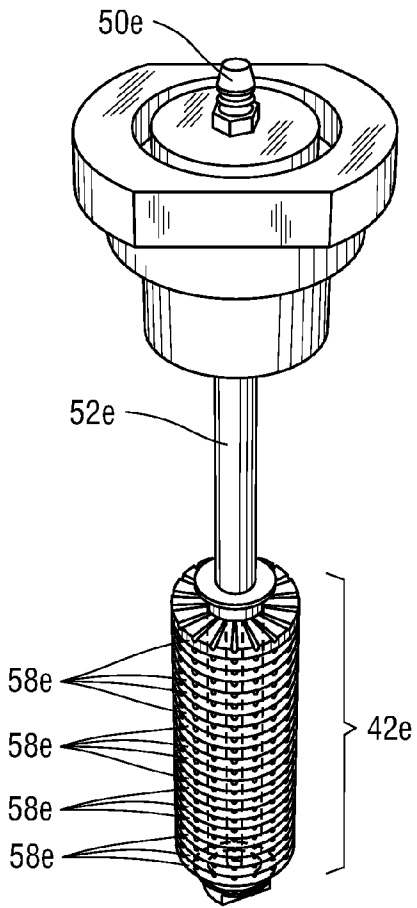

Fig. 7C

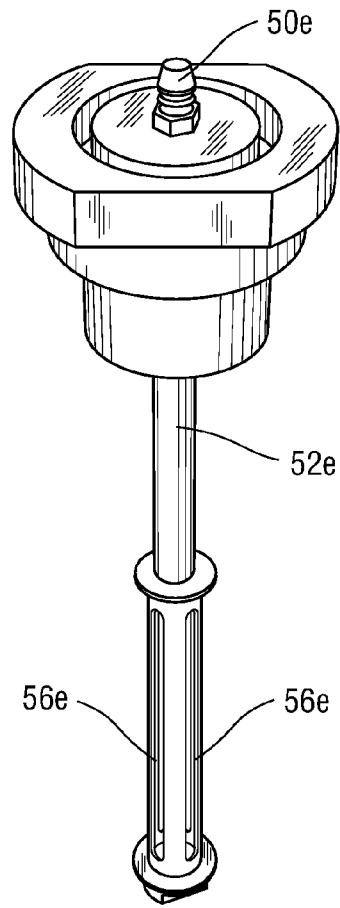

Fig. 7D

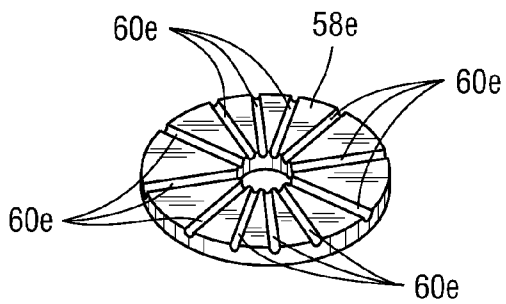

Fig. 7E

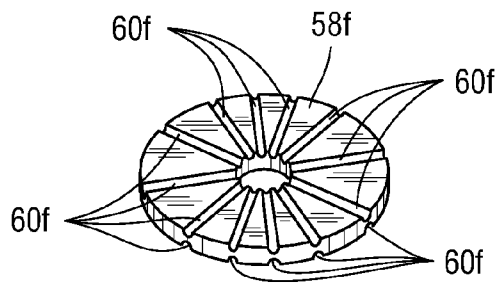

Fig. 8

9/24

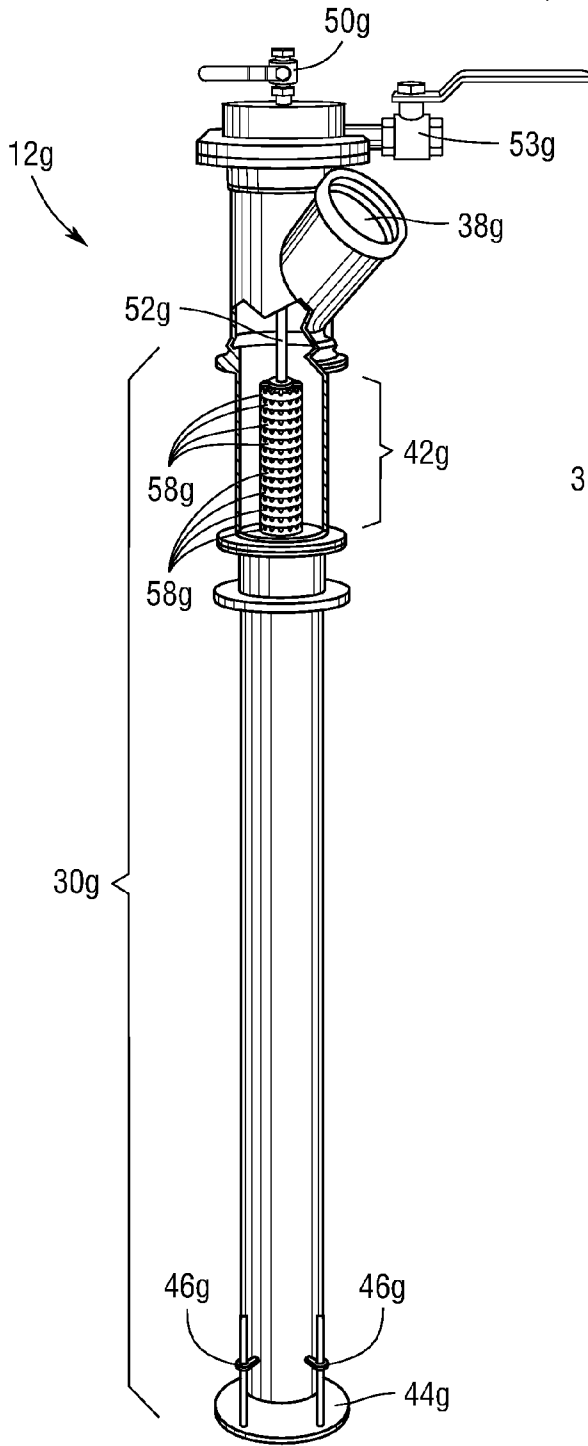

Fig. 9A

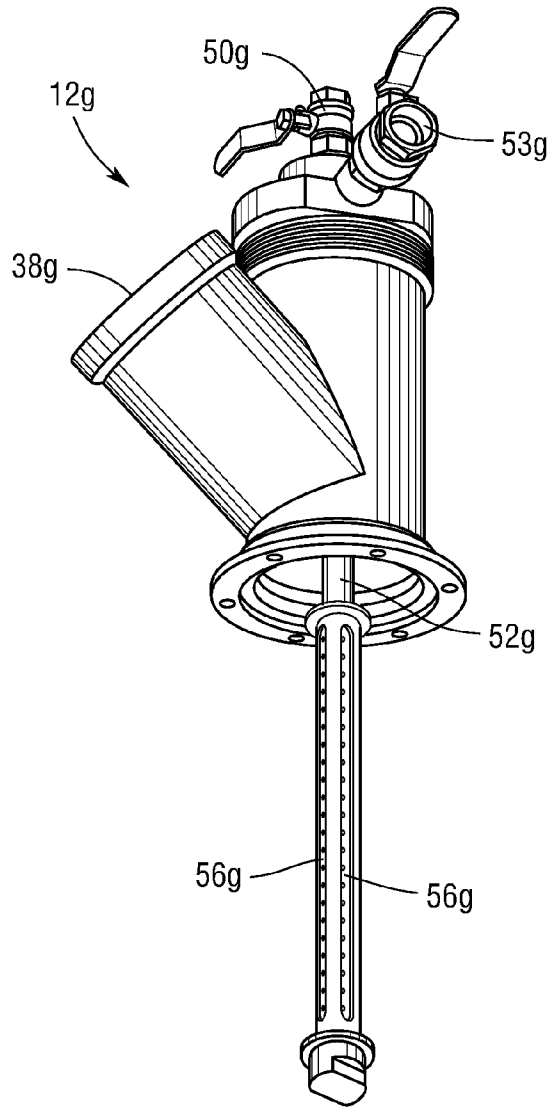

Fig. 9B

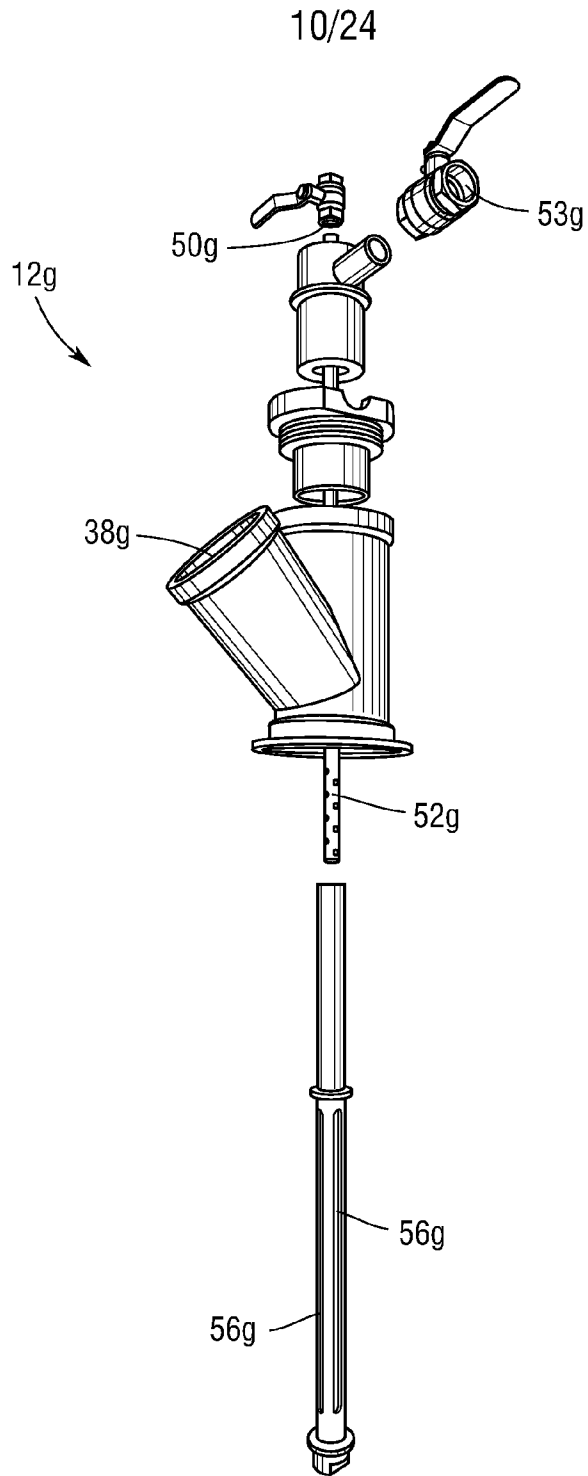

Fig. 9C

11/24

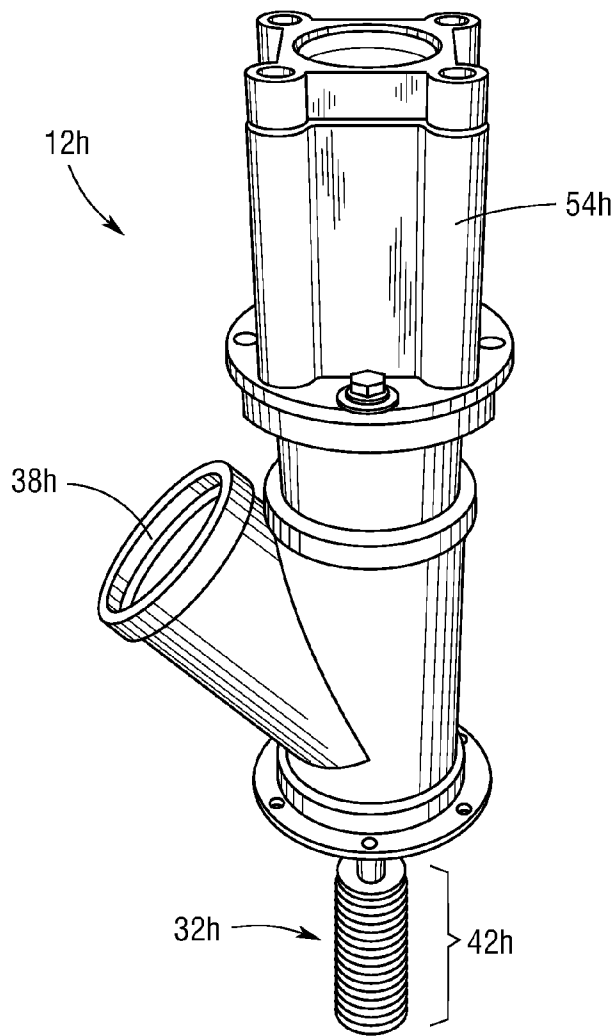

Fig.10

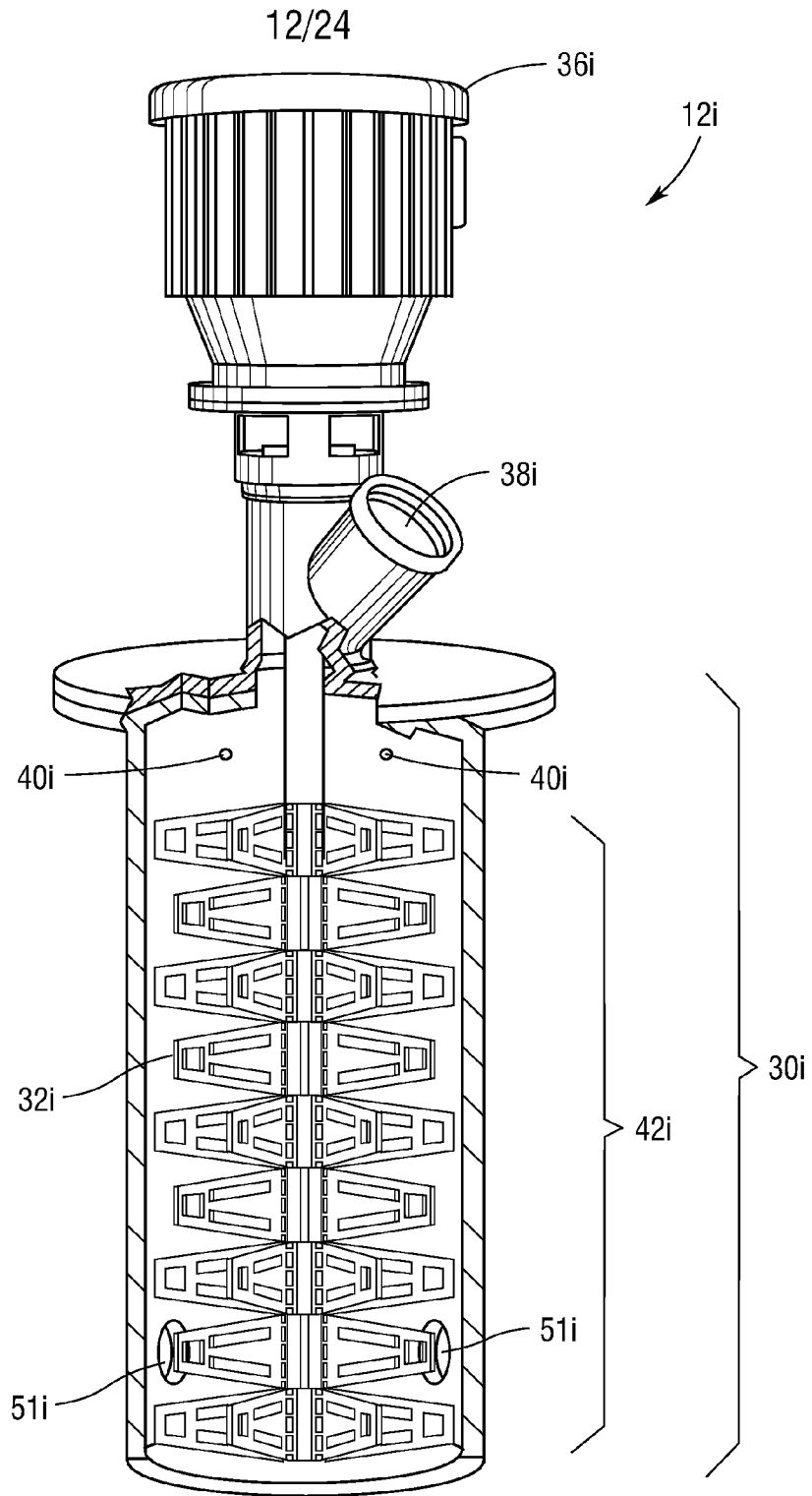

Fig.11

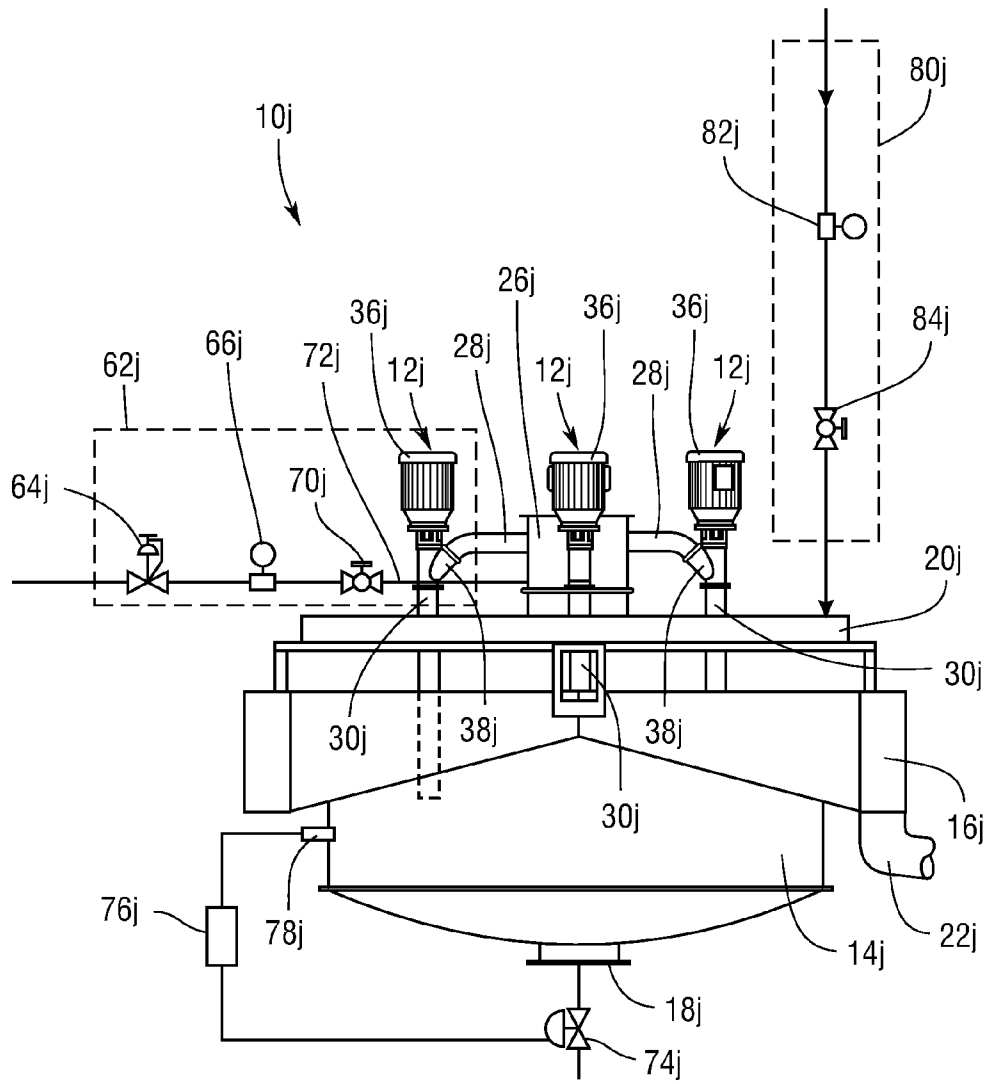

Fig.12

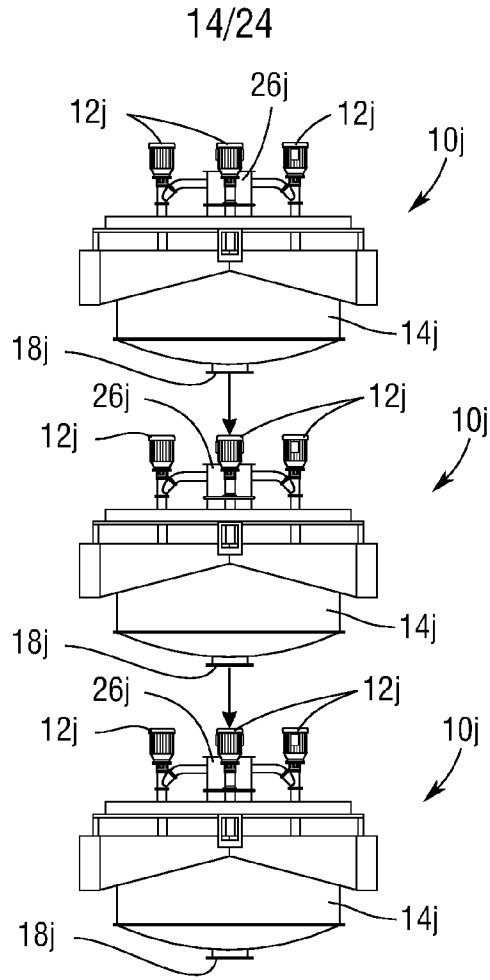

Fig. 13

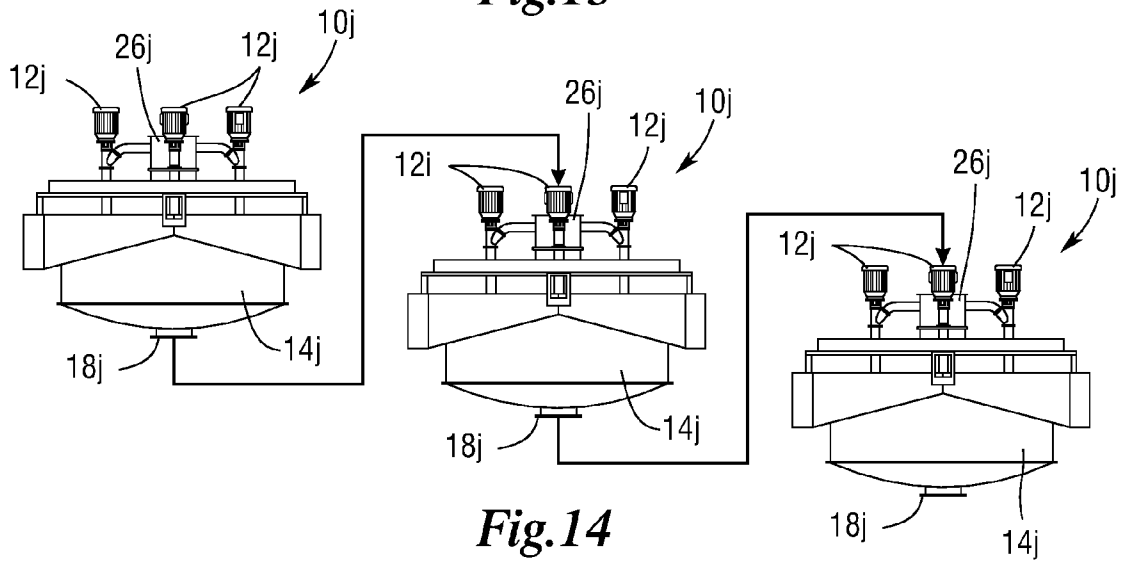

Fig. 14

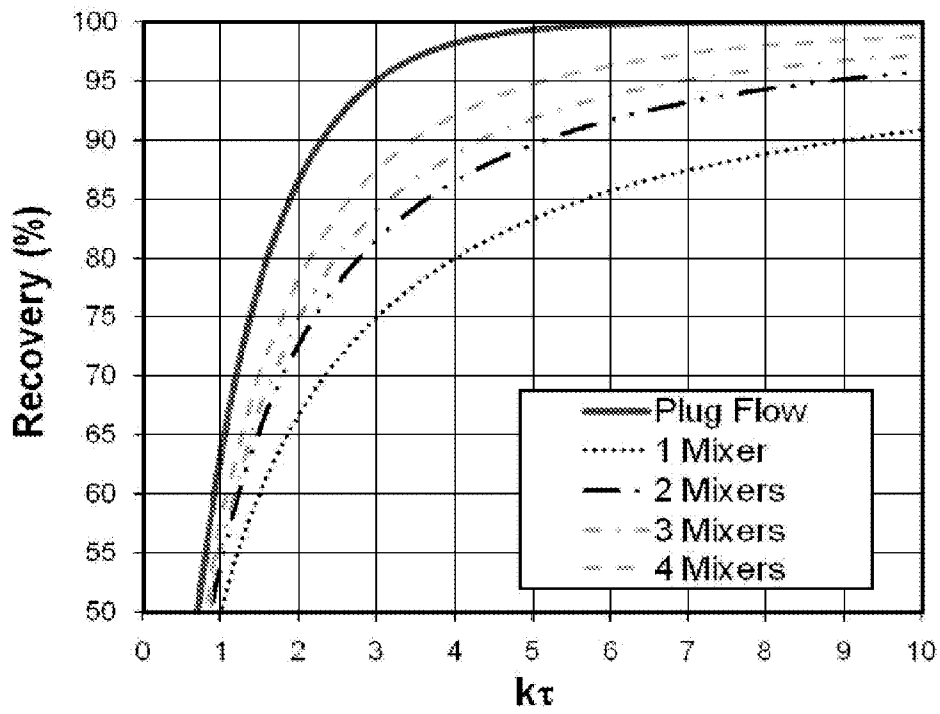

Fig.15

16/24

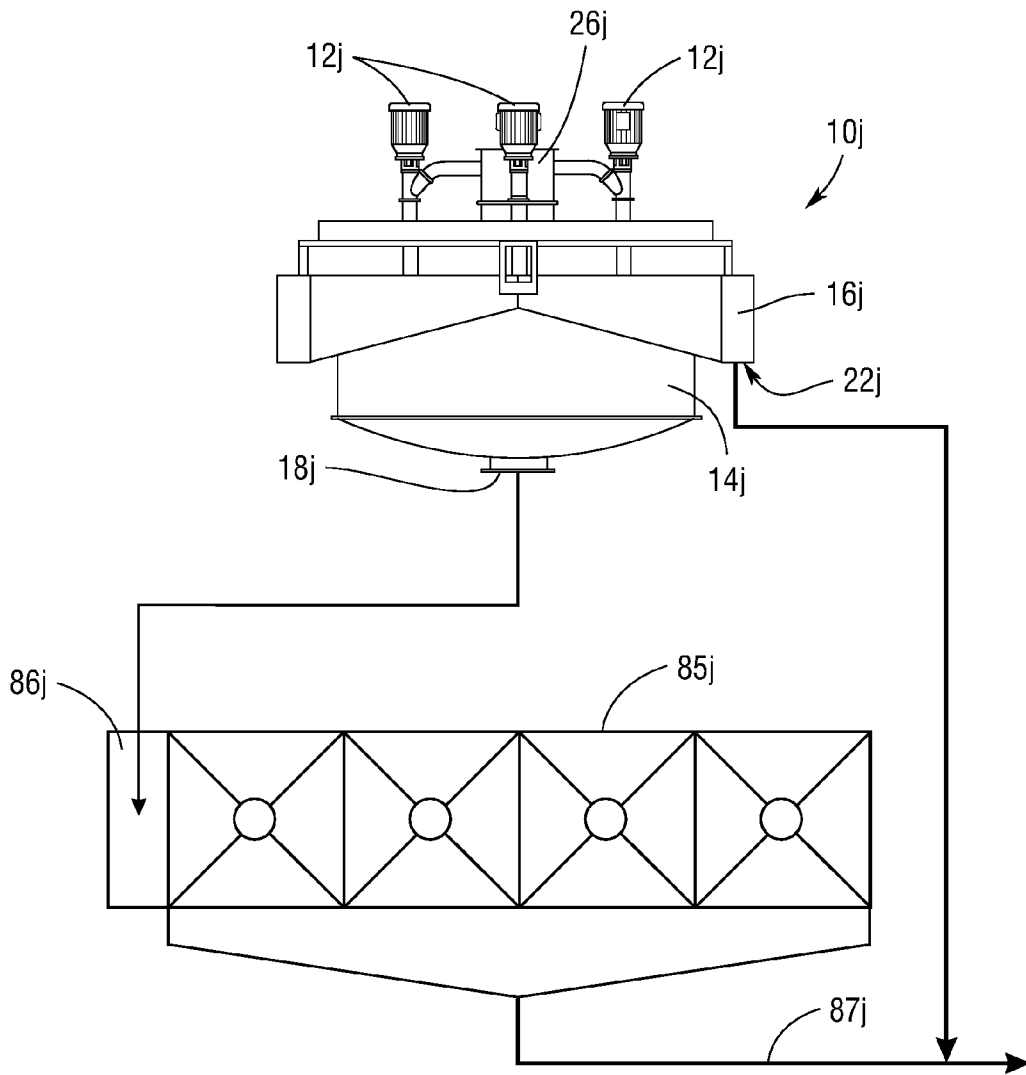

Fig.16A

17/24

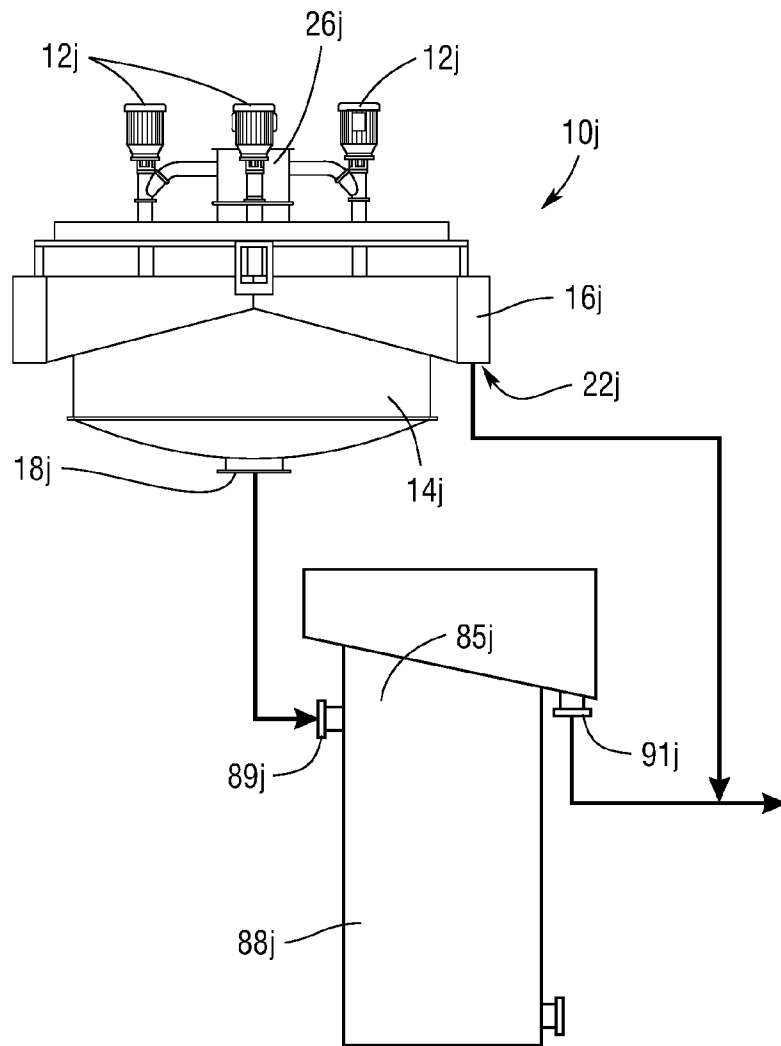

Fig.16B

19/24

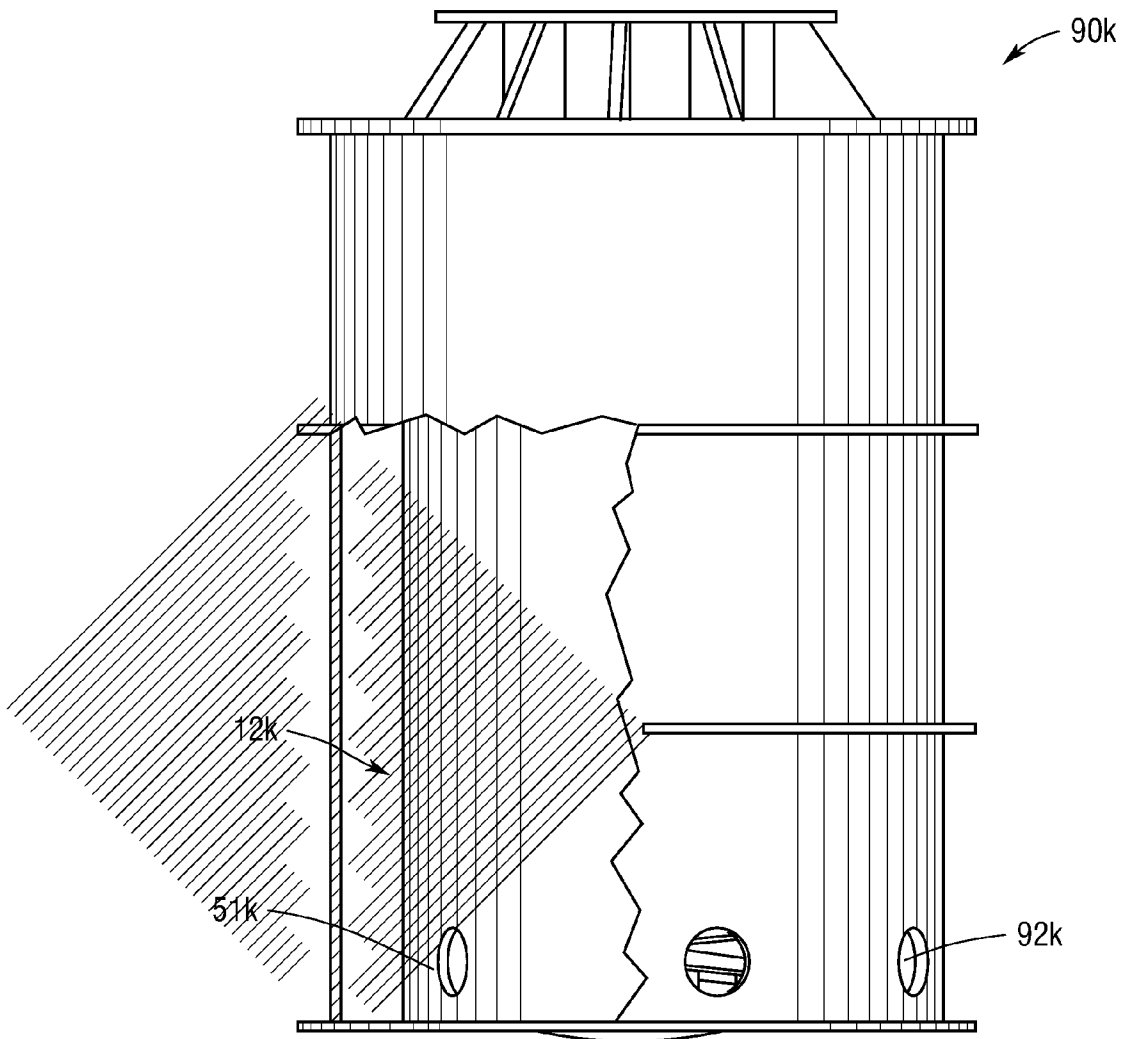

Fig.17B

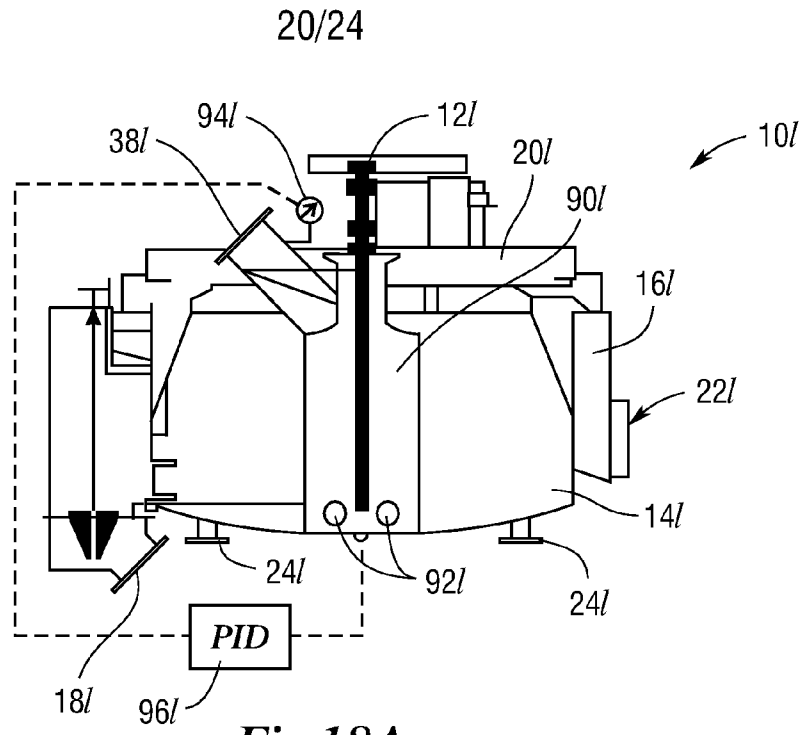

Fig.18A

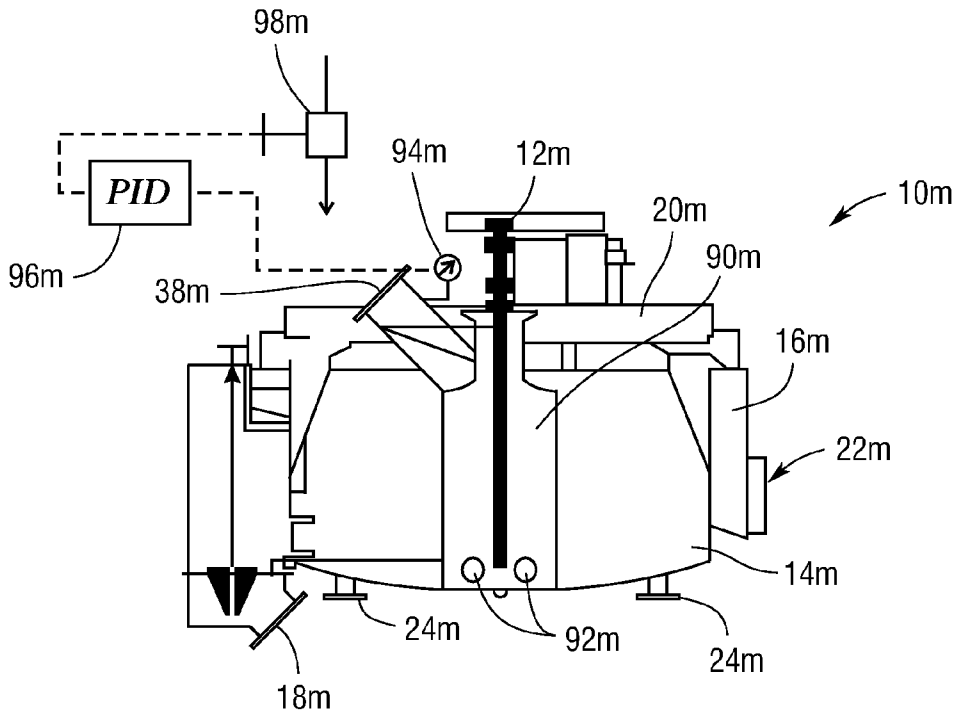

Fig.18B

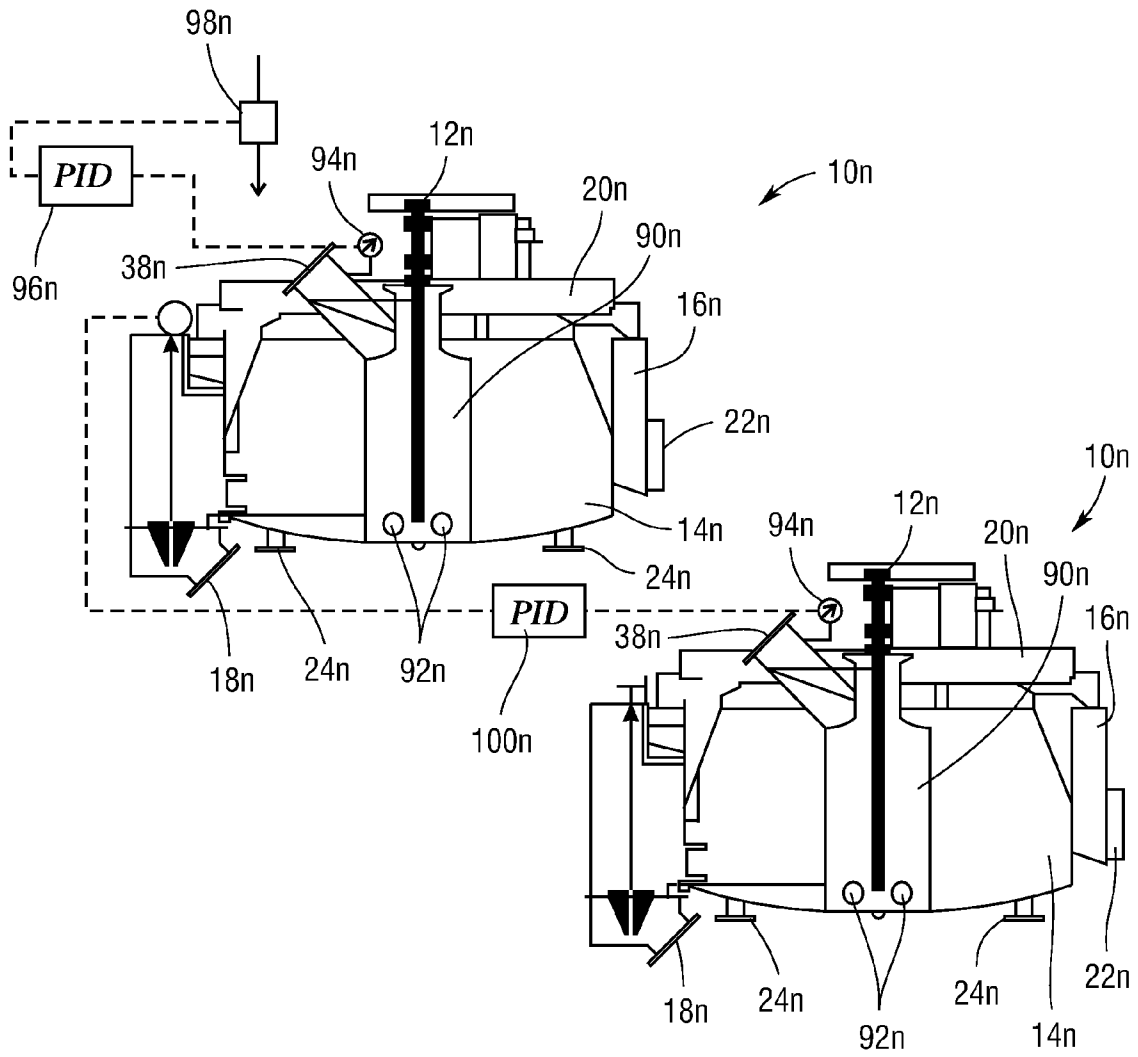

Fig.18C

22/24

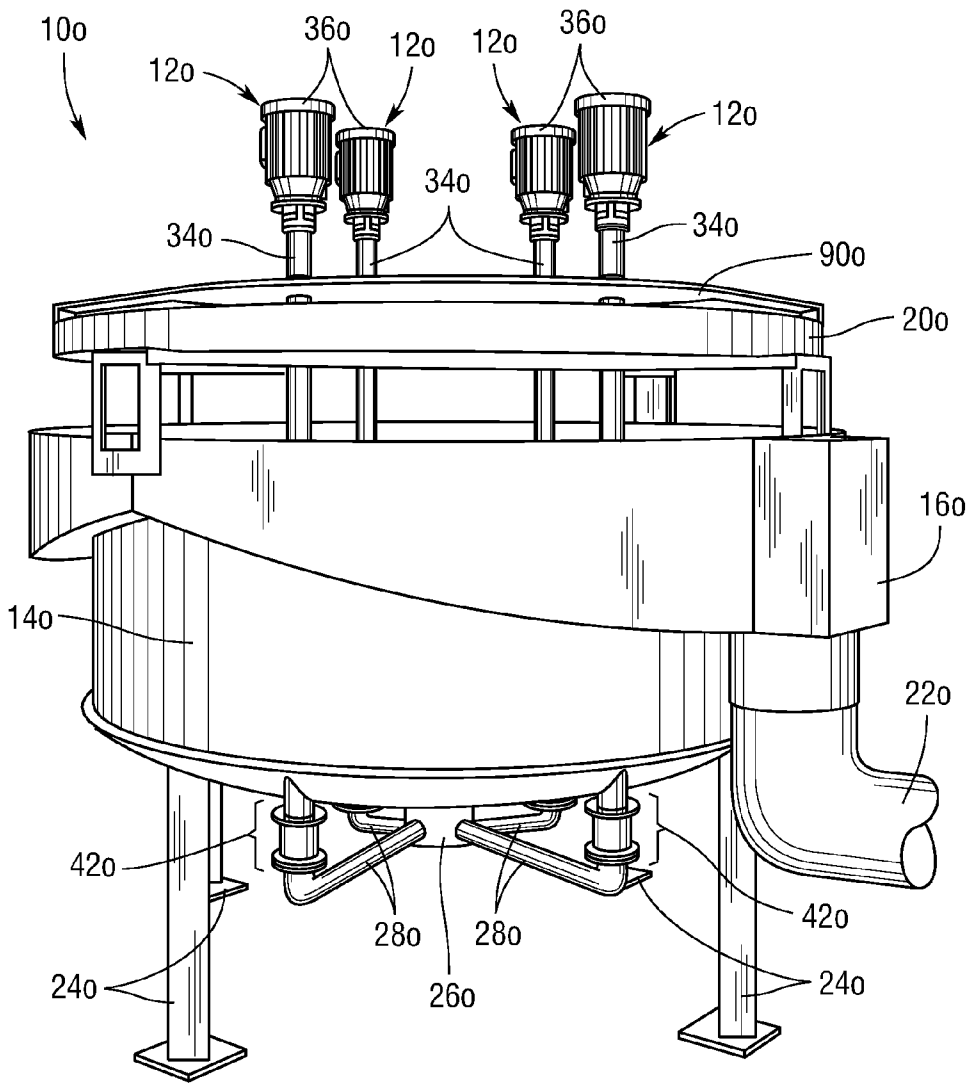

Fig.19

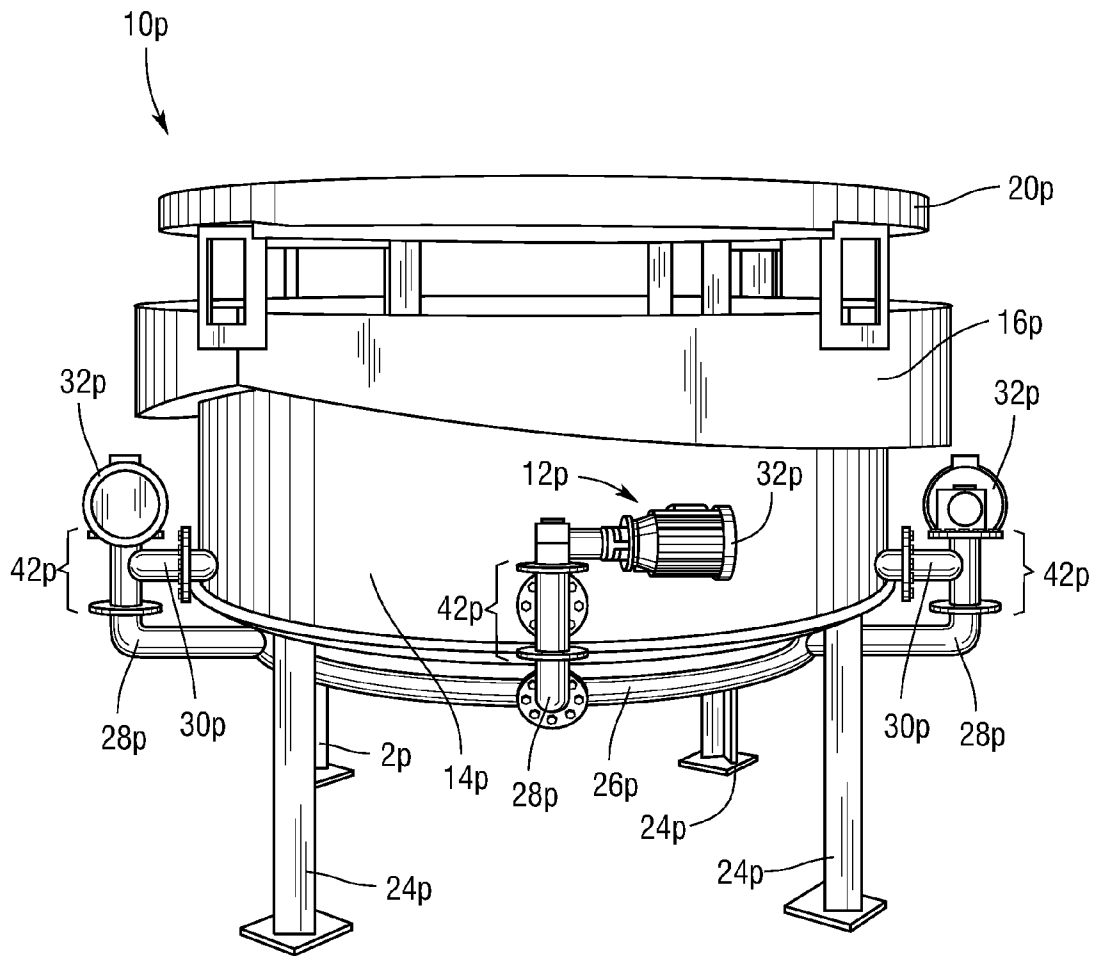

Fig. 20

24/24

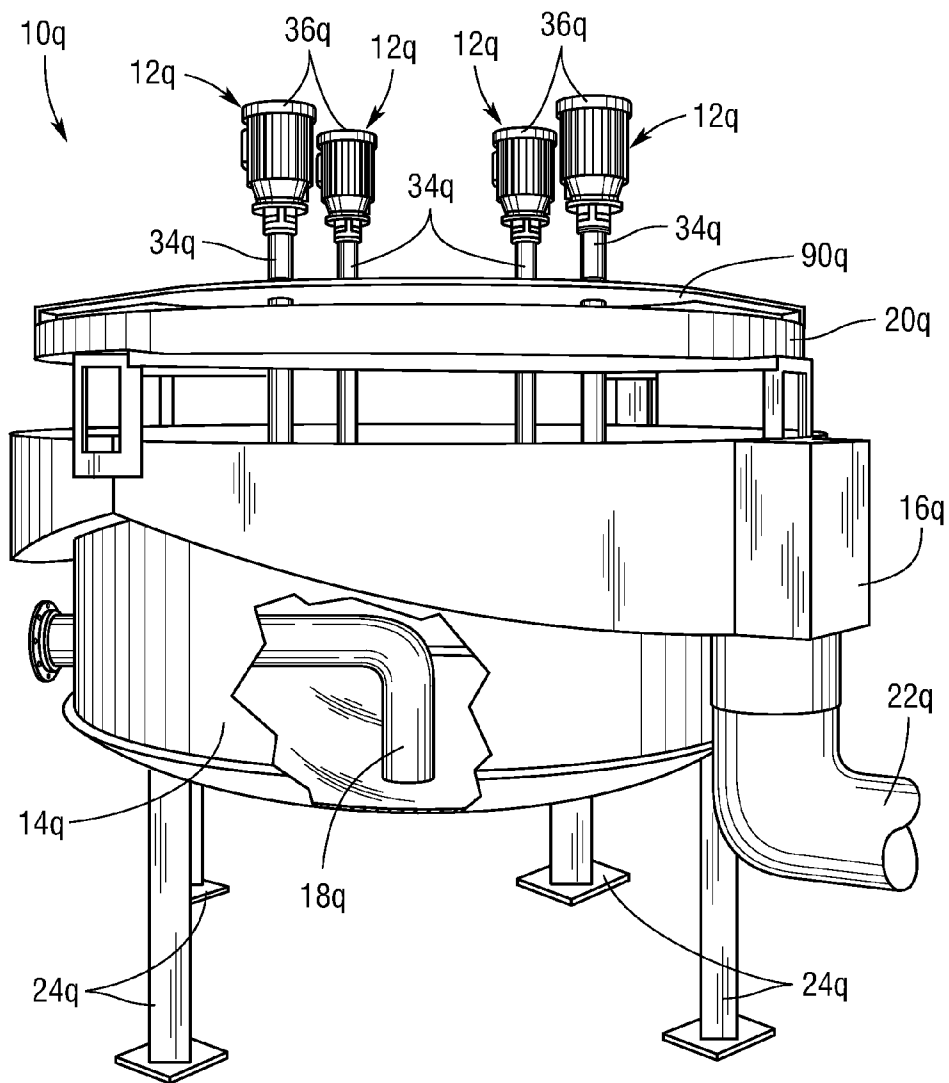

Fig.21