

Nov. 13, 1962

G. D. BLACK
SELF-EXPANDABLE BAG

3,063,620

Filed Jan. 6, 1960

2 Sheets-Sheet 1

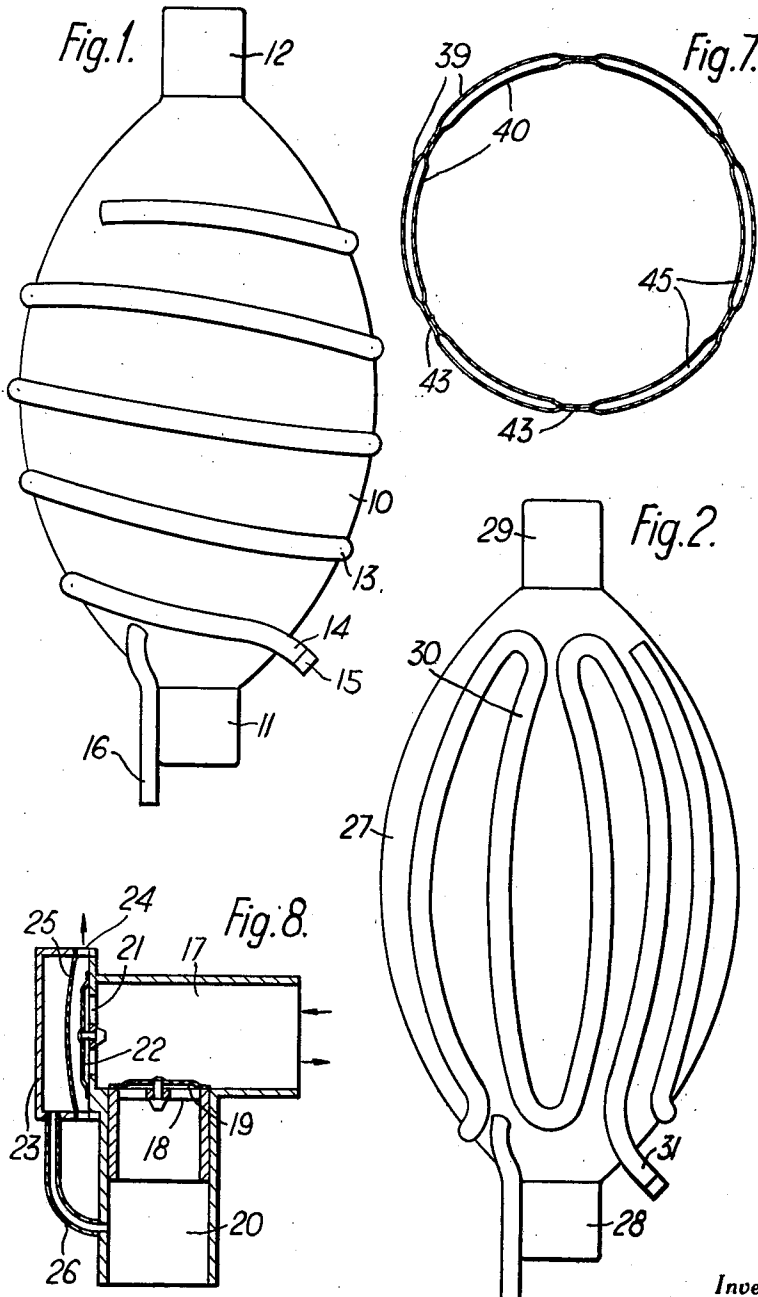

Inventor
Geoffrey D. Black
By
Caron R. Tournas Attorney

Nov. 13, 1962

G. D. BLACK

3,063,620

SELF-EXPANDABLE BAG

Filed Jan. 6, 1960

2 Sheets-Sheet 2

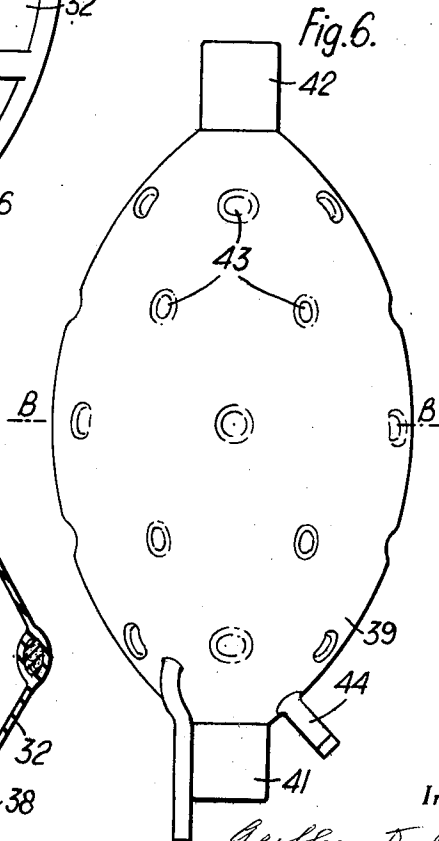
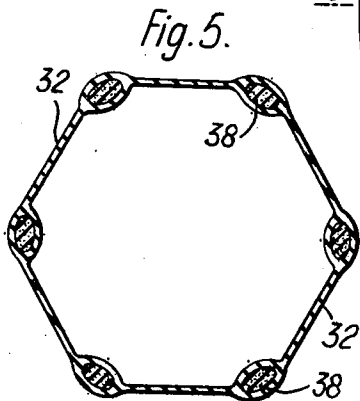
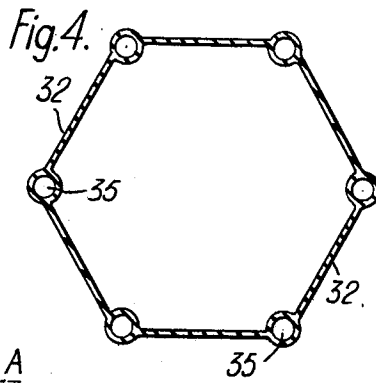
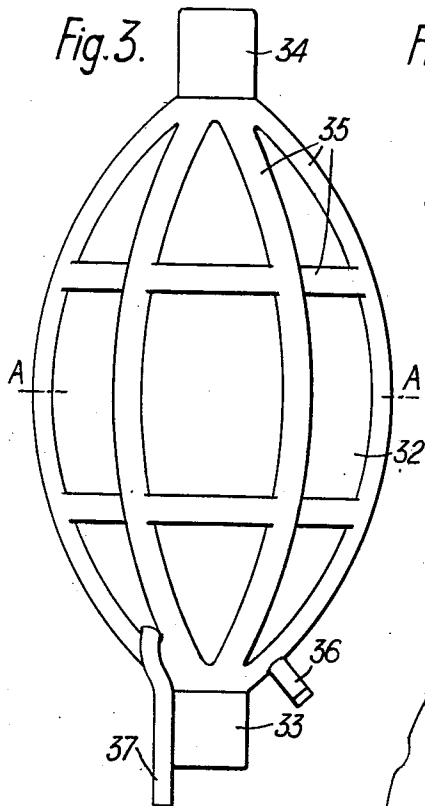

Inventor

Geoffrey D. Black

By

Aaron R. Townsend
Attorney

1

3,063,620

SELF-EXPANDABLE BAG

Geoffrey Donald Black, Sawbridgeworth, England, assignor to The British Oxygen Company Limited, a company of Great Britain

Filed Jan. 6, 1960, Ser. No. 747

Claims priority, application Great Britain Jan. 6, 1959

1 Claim. (Cl. 230-43)

This invention relates to self-expandable bags for use in administering inhalant gas. Such bags are intended primarily for use in the application of intermittent positive pressure resuscitation.

Self-expandable bags are known having a valved inlet through which air or other gas may enter the bag, and a valved outlet for connection to a face mask or the like, so that when the bag is compressed by the operator, the contents are forced into the lungs of the patient and when the pressure is released the bag expands to draw in a fresh supply of gas whilst the patient exhales to atmosphere. The valve in the outlet functions both as a non-return valve and an exhalation valve, being arranged to permit gas to flow only from the bag to the lungs during inhalation and from the lungs to atmosphere during exhalation.

The advantage of the self-expandable bag is that it enables the "bag and mask" method of artificial respiration commonly practised in the operating theatre to be used under emergency conditions away from the theatre, for example at the scene of an accident, or during transport of a patient.

Self-expanding bags as proposed heretofore, even when in the collapsed condition, are relatively bulky due to the space occupied by the means provided for expanding the bag. Such means may, for example, comprise springs or foam rubber or plastic.

It is an object of the present invention to provide a self-expandable bag for use in administering inhalant gas, which may readily be collapsed when not in use so as to occupy a minimum of space during storage.

According to the present invention there is provided a self-expandable bag for use in administering inhalant gas comprising a substantially gas impervious envelope with at least one opening and at least one tubular inflatable element associated with the envelope to form an integral part of the bag, the element when inflated causing the bag, after compression, to assume the expanded state.

According to a feature of the invention a single inflatable element in the form of a tubular channel extends around the circumference of the bag along a substantially helical or zig-zag path, the channel having a connection for fluid under pressure.

According to another feature of the invention the inflatable elements comprise a system of intercommunicating tubular channels extending around the circumference of the bag, said channels having a connection for fluid under pressure.

The channels may be either secured to or formed integrally with the wall of the envelope. They may be unobstructed tubes or they may be filled with interconnected cell sponge rubber or plastic. The latter form may have the advantage that the walls of the channels cannot seal themselves together during prolonged storage.

According to a further feature of the invention the envelope is a double-walled structure, the walls being united at a plurality of points in spaced relationship, and a connection for fluid under pressure leading to the interspace.

Fluid, for example air, may be introduced into the connection by blowing with the mouth or by means of a syringe or pump. The connection may be provided

2

with a displaceable non-return valve to enable pressurising fluid to be released at will from the channels or the interspace.

For use in administering gas the bag has an inlet provided with a non-return valve through which gas may enter the envelope and an outlet provided with a non-return valve through which gas may be expelled from the envelope. The non-return valve in the outlet preferably functions also as an expiratory valve.

The inlet and outlet may have a common connection to the mouth of the bag but are more conveniently located at opposite ends of the bag. The envelope may be made, for example, from rubber or rubberized fabric.

If desired a second inlet to the bag may be provided for connection to a supply of oxygen or other gas.

The invention will now be described by way of example with reference to the drawings in which

FIGS. 1, 2, 3 and 6 are side elevations of alternative forms of bags constructed in accordance with the invention,

FIG. 4 is a section taken along the line A—A of FIG. 3,

FIG. 5 is a section taken along the line A—A of FIG. 3 showing an alternative form of internal construction, FIG. 7 is a section taken along the line B—B of FIG. 6, and

FIG. 8 illustrates diagrammatically an inspiratory/expiratory valve suitable for location in the outlet of any of the bags shown in FIGS. 1, 2, 3 and 6.

The embodiment illustrated in FIG. 1 shows an ovoid rubber bag comprising an envelope 10 having an inlet 11 at one end and an outlet 12 at the other end. An inflatable element consisting of a rubber tube 13 is bonded to the wall of the envelope and extends in a helical path over its circumference. The tube 13 is adapted to be inflated either ovaly or from a suitable source of fluid under pressure through a connection 14 provided with a plug 15. Instead of the plug 15 a displaceable non-return valve may be located in the connection 14.

A second gas inlet 16 to the interior of the bag is adapted for connection to a supply of oxygen or other gas. The bag may be made by a conventional rubber dipping process. For example, the envelope 10 may be produced by dipping a former in rubber latex solution. The tube 13 is wound around the envelope and the whole assembly is then cured whereby the tube becomes bonded to the wall of the envelope.

When the bag is to be used for administering gas, the inlet 11 is fitted with a non-return valve through which air may be drawn into the envelope, and the outlet 12 is fitted with a non-return valve which functions also as an expiratory valve. A suitable valve, which is illustrated in FIG. 8, consists of a tubular member 17, intended for connection to a face piece for the patient, having a port 18 closed by a flap valve member 19 through which gas is admitted from a passage 20 communicating with the interior of the envelope 10, and another port 21 closed by a flap valve member 22 through which exhaled gases are permitted to escape into a chamber 23 provided with vents 24 to atmosphere. The chamber 23 is divided by a diaphragm 25, one side of the diaphragm being subjected to atmospheric pressure through the vents 24, and the other side to a pressure equal to the pressure in passage 20 acting through a duct 26 which connects the passage 20 to the chamber 23.

In use, the tubular member 13 is inflated, thus causing the bag to expand and draw in air through the valved inlet 11. Oxygen-enrichment of the air is provided by connecting the second gas inlet 16 to a supply of oxygen. When the bag is squeezed, air is forced through the passage 20 and past the valve member 19 into the patient's

3

lungs. At the same time the diaphragm 25 is deflected inwards to bear against the valve member 22 and maintain it in sealing engagement with the port 21. When pressure on the bag is released, it expands under the influence of the inflated tube 13 to draw in a fresh supply of air. The pressure acting on the diaphragm 25 is simultaneously relieved, the diaphragm moves outwards, and the valve 22 opens to permit the exhaled gases to escape via the port 21 and vents 24 to atmosphere.

The bag illustrated in FIG. 2, which shows a different arrangement of the inflatable element, consists of a flexible rubber envelope 27 having an inlet 28 and an outlet 29, a tube 30 extending in a zig-zag path over its circumference and adapted to be inflated through a connection 31.

Another alternative form of bag is illustrated in FIG. 3 and consists of a flexible rubber envelope 32 having an inlet 33 at one end and an outlet 34 at the other end and a system of interconnected tubular channels 35 adapted to be inflated through a connection 36. A second gas inlet 37 is provided for admission of oxygen or other gas. The channels are so arranged that when they are inflated, the medial portion of the bag exerts the least resistance to compression. When the bag is squeezed the tendency to bulge at each end is thus reduced and the maximum volume of gas can be expelled. The tubular channels 35 may be unobstructed tubes as shown in FIG. 4, or they may be filled with interconnected cell sponge rubber or plastic 38 as shown in FIG. 5. This form of bag may be manufactured by dipping a former in rubber latex solution, applying a skeleton of metal former tubes to the envelope so produced, and redipping. The whole assembly is then partially cured before the metal tubes are withdrawn. If the tubular channels are to be filled with sponge rubber, a skeleton of sponge rubber tubes replaces the metal former tubes during manufacture.

Referring to FIGS. 6 and 7, another form of bag is illustrated which is constructed from two sheets 39 and 40 of substantially gas impervious material sealed to-

4

gether at each end around an inlet 41 and outlet 42 and also sealed together at a plurality of points 43 in spaced relationship. An inflating connection 44 leads into the interspace 45 between the two sheets.

After use, pressure in the inflatable elements, constituted by the channels 13, 30, 35 and the interspace 40 respectively, is released to collapse the bag for packing.

In the collapsed state any of the bags illustrated may be utilized for oxygen therapy, the patient on spontaneous breathing drawing in air enriched with oxygen, or if the oxygen flow is increased to keep the bag inflated, pure oxygen.

I claim:

A self-expandable bag for use in administering inhalant gas comprising a substantially gas impervious envelope including an inlet and an outlet, at least one tubular inflatable element extending around the external circumference of the envelope to form a unitary integral part of the bag, said element being filled with interconnected cell cellular material, said element when inflated causing the bag to assume an expanded state, said inlet in said bag adapted to admit inhalant gas thereto and said outlet adapted to discharge said inhalant gas therefrom, said inlet and said outlet each provided with a non-return valve and said self-expandable bag having a second inlet for connection to a source of another inhalant gas.

References Cited in the file of this patent

UNITED STATES PATENTS

2,280,050	Alexander	Apr. 21, 1942
2,834,339	Bennett	May 13, 1958
3,009,459	Ruben	Nov. 21, 1961

FOREIGN PATENTS

923,570	Germany	Feb. 17, 1955
---------	---------	---------------

OTHER REFERENCES

German application Ser. No. P 13321, printed April 26, 1956 (KI. 27a).