



(51) International Patent Classification:

A61B 5/0488 (2006.01) A63F 13/28 (2014.01)
A61B 5/11 (2006.01)

(21) International Application Number:

PCT/US2018/027825

(22) International Filing Date:

16 April 2018 (16.04.2018)

(25) Filing Language:

English

(26) Publication Language:

English

(30) Priority Data:

62/485,885 14 April 2017 (14.04.2017) US

(71) Applicant: **REHABILITATION INSTITUTE OF CHICAGO D/B/A SHIRLEY RYAN ABILITYLAB** [US/US]; 355 East Erie Street, Chicago, Illinois 60611 (US).

(72) Inventors: **HARGROVE, Levi, J.**; 355 E. Erie St., Chicago, Illinois 60611 (US). **WOODWARD, Richard, B.**; 355 E. Erie St., Chicago, Illinois 60611 (US).

(74) Agent: **PAHNKE, Chad, A.**; McAndrews, Held & Malloy, LTD., 500 W. Madison, 35th Floor, Chicago, Illinois 60661 (US).

(81) Designated States (unless otherwise indicated, for every kind of national protection available): AE, AG, AL, AM, AO, AT, AU, AZ, BA, BB, BG, BH, BN, BR, BW, BY, BZ, CA, CH, CL, CN, CO, CR, CU, CZ, DE, DJ, DK, DM, DO,

DZ, EC, EE, EG, ES, FI, GB, GD, GE, GH, GM, GT, HN, HR, HU, ID, IL, IN, IR, IS, JO, JP, KE, KG, KH, KN, KP, KR, KW, KZ, LA, LC, LK, LR, LS, LU, LY, MA, MD, ME, MG, MK, MN, MW, MX, MY, MZ, NA, NG, NI, NO, NZ, OM, PA, PE, PG, PH, PL, PT, QA, RO, RS, RU, RW, SA, SC, SD, SE, SG, SK, SL, SM, ST, SV, SY, TH, TJ, TM, TN, TR, TT, TZ, UA, UG, US, UZ, VC, VN, ZA, ZM, ZW.

(84) Designated States (unless otherwise indicated, for every kind of regional protection available): ARIPO (BW, GH, GM, KE, LR, LS, MW, MZ, NA, RW, SD, SL, ST, SZ, TZ, UG, ZM, ZW), Eurasian (AM, AZ, BY, KG, KZ, RU, TJ, TM), European (AL, AT, BE, BG, CH, CY, CZ, DE, DK, EE, ES, FI, FR, GB, GR, HR, HU, IE, IS, IT, LT, LU, LV, MC, MK, MT, NL, NO, PL, PT, RO, RS, SE, SI, SK, SM, TR), OAPI (BF, BJ, CF, CG, CI, CM, GA, GN, GQ, GW, KM, ML, MR, NE, SN, TD, TG).

Published:

— with international search report (Art. 21(3))

(54) Title: PROSTHETIC VIRTUAL REALITY TRAINING INTERFACE AND RELATED METHODS

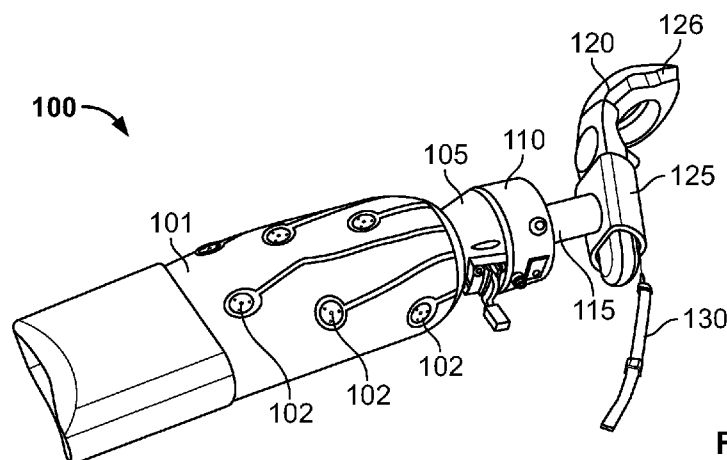

FIG. 1A

(57) Abstract: An apparatus comprising an electromyographic (EMG) control module may be configured to receive EMG information generated by an individual in response to a virtual reality display indicating a gesture class; train using the received EMG information and the gesture class; and after training, operate an assistive device.



Prosthetic Virtual Reality Training Interface and Related Methods

STATEMENT OF GOVERNMENT SUPPORT

[0001]. This invention was made with government support under W81XWH-15-2-0035 awarded by the United States Department of Defense. The government has certain rights in the invention.

RELATED APPLICATIONS

[0002]. This application claims benefit to U.S. Provisional Patent Application No. 62/485,885 filed on April 14, 2017, which is incorporated by reference.

FIELD

[0003]. This disclosure generally relates to the fields of virtual reality (VR) and rehabilitation devices, in particular a rehabilitation VR system for therapeutic, training, and diagnostic purposes.

BACKGROUND

[0004]. Limb loss and neurological disorders such as stroke, spinal cord injury, and cerebral palsy are significant medical conditions that can severely impact a person's quality of life and the life of their caregivers. Returning to a high level of ability post-injury requires specialized rehabilitation therapies and technologies. If prosthetics are needed, in order for those with these conditions to use the latest technology like myoelectric prostheses, extensive training is required. This training can be frustrating for a prosthesis user because the prosthesis does not work well at the start of training.

[0005]. Electromyographic (EMG) signals are electrophysiological signals generated by a muscular contraction which propagates spatially through the body. The origin of the signal is the depolarization and repolarization of the muscle fiber cell membrane during a contraction which

causes ionic currents to circulate creating measurable action potentials in the body. Individual muscle fibers are innervated in groups by a single nerve axon. This functional unit, consisting of the group of muscle fibers, nerve axon, and cell body of the nerve in the spinal cord is called a motor unit (MU). An MU generates a force twitch each time it is activated and an associated motor unit action potential (MUAP) is generated. The total force produced by the muscle is a superposition of all MU force twitches while the detected EMG is a superposition of all MUAPs and it can be detected at the skin's surface using surface electrodes or underneath the skin using invasive techniques. The nervous system has two general means to modulate the force of a muscle contraction: 1) by varying the number of recruited MUs, or 2) by modulating the firing rate of the recruited MUs. For either of these two conditions, the peak-to-peak amplitude and variance of the detected EMG increases in a roughly linear manner as force production increases. Thus, control signal(s) can be generated through a conscious voluntary effort by varying the intensity of a muscular contraction(s). This is true of healthy muscles, muscles atrophied through disuse, partially innervated muscles, and of normally innervated muscle remnants resulting from amputation.

SUMMARY

[0006]. An apparatus comprising an electromyographic (EMG) control module may be configured to receive EMG information generated by an individual in response to a virtual reality display indicating a gesture class; train using the received EMG information and the gesture class; and after training, operate an assistive device.

[0007]. The EMG control module may be configured to determine an intended gesture based on the EMG information; and output a gesture instruction associated with the intended gesture. The gesture instruction may be defined as a scalar value. The apparatus may further

comprise a sensor system, the sensor system comprising a kinematic actuator for providing kinematic information about the individual to a virtual reality control module.

[0008].In response to the gesture instruction, the virtual reality display may display a virtual limb in a position reflecting the intended gesture. In response to the gesture instruction, the virtual reality display may show a trace line originating at a limb avatar and terminating at a virtual target. An image representing the intended gesture may be displayed on the virtual target.

[0009].The EMG control module may be defined as a pattern recognition classifier. The EMG control module may comprise a plurality of gesture classes. The gesture classes may comprise a hand open class, a hand close class, a no motion class, a wrist rotation class, and a wrist extension/flexion class. The EMG signals generated by the individual may be generated by the individual's limb moving in more than one physical dimension. The EMG signals generated by the individual may be generated by the individual's limb moving in three physical dimensions.

[0010].The virtual limb may be displayed as a shooting device. The virtual reality display may be configured to display a virtual target. The virtual reality display may be configured to display a virtual target and the virtual target disappears if the virtual limb is not pointed at the virtual target after a predetermined period of time.

[0011].In an embodiment, an apparatus comprising an electromyographic (EMG) control module may be defined as a pattern recognition classifier, the EMG control module configured to receive EMG information generated by movement of an individual's limb in more than one physical dimension in response to a virtual reality display indicating a gesture class; and train using the received EMG information and the gesture class. Each class in the classifier may be

trained using EMG information received from user movement in more than one physical dimension.

[0012]. This Summary is provided to introduce a selection of concepts in a simplified form that are further described below in the Detailed Description. This Summary is not intended to identify key or essential features of the claimed subject matter, nor is it intended to be used as an aid in determining the scope of the claimed subject matter.

BRIEF DESCRIPTION OF THE DRAWINGS

[0013]. The Detailed Description is described with reference to the accompanying figures. The same reference numbers in different figures indicate similar or identical items. References made to individual items of a plurality of items can use the same reference number.

[0014]. **FIG. 1A** is a perspective view of an exemplary virtual reality training device.

[0015]. **FIG. 1B** is a block diagram of an exemplary controller and sensors of the exemplary virtual reality training device shown in **FIG. 1A**.

[0016]. **FIG. 2** is an exploded side view of portions of the exemplary virtual reality training device shown in **FIG. 1A**.

[0017]. **FIG. 3** is a representation of a person using the exemplary virtual reality training device shown in **FIG. 1A** in coordination with an exemplary VR interface.

[0018]. **FIG. 4** shows an exemplary myoelectric arm band.

[0019]. **FIG. 5** shows the exemplary myoelectric arm band of **FIG. 4** attached to the residual limb of a user.

[0020]. **FIG. 6** is a block diagram of the exemplary arm band shown in **FIG. 4**.

[0021]. **FIG. 7** is a block diagram of an exemplary interface.

[0022].**FIG. 8** is a view of an exemplary virtual reality display corresponding to static training.

[0023].**FIG. 9** is another view of the exemplary virtual reality display in **FIG. 8**.

[0024].**FIG. 10** is a view of an exemplary virtual reality display corresponding to dynamic training.

[0025].**FIG. 11A** is a virtual reality representation of an exemplary limb avatar.

[0026].**FIG. 11B** is a virtual reality representation of the exemplary limb avatar shown in **FIG. 11A**, partially superimposed over an exemplary target position.

[0027].**FIG. 11C** is a virtual reality representation of the exemplary limb avatar shown in **FIG. 11A** fully superimposed over the exemplary target position of **FIG. 11B**.

[0028].**FIG. 12** is a block diagram of an exemplary EMG controller.

[0029].**FIG. 13** is a representation of exemplary positions of targets in a virtual environment.

[0030].Corresponding reference characters indicate corresponding elements among the view of the drawings. The headings used in the figures should not be interpreted to limit the scope of the claims.

DETAILED DESCRIPTION

[0031].A virtual reality (VR) interface for individuals is disclosed. The VR interface may provide individuals with physical disabilities self-administered and targeted rehabilitation within a home or clinical setting. In an embodiment, the VR interface may comprise an apparatus for control of the virtual reality device. The VR interface may further comprise independent virtual reality software for training, monitoring, or diagnostic purposes. The data from the VR interface may be analyzed and used to train a prosthesis to understand an individual's specific

muscle movements. In other embodiments, the VR interface may be used in connection with VR systems for persons with neurological disorders such as amputations, stroke, spinal cord injury, or cerebral palsy. The foregoing and other aspects will become more apparent from the following detailed description when considered in conjunction with the accompanying drawings.

[0032]. In one embodiment, a virtual reality (VR) training system is disclosed that provides enjoyable, self-administered, and targeted rehabilitation to upper-limb amputees within a home or clinical setting in order to increase the functional utilization and efficient training in the use of myoelectric prostheses in daily living activities. **FIG. 1** displays an exemplary VR assistive device **100** comprising an instrumented liner **101**, a magnetic electrical interface (MEI) **105**, muscle computer interface (MCI) **110**, stem **115**, controller **120**, controller support **125**, and wrist strap **130**. The controller **120** may be a controller used to operate a commercially available video game. Stem **115** and controller support **125** may be 3D printed or made of any other suitable material. The length of stem **115** may be adjusted to match the amputee's residual limb length. The liner **101** may be of the kind disclosed in U.S. Patent No. US 9,155,634 B2, titled Systems and methods of myoelectric control, incorporated by reference. MEI **105** may be of the kind disclosed in U.S. Patent Publication No. US-2016-0038314-A1, Magnetic Electrical Connector for Assistive Devices, incorporated by reference.

[0033]. Controller **120** may allow both mechanical and electrical actuation. Controller support **125** may hold the controller **120** in place. The MCI **110** may comprise a power source such as a battery, an embedded control system, and an interface to the controller **120**. The liner **101** comprises one or more sensors **102**. The liner **101** is placed over a user's residual limb and the sensors **102** can receive electromyographic (EMG) information from the user's residual limb. The MCI **110** can process the EMG information from the sensors **102**, interpret the information

to determine user intention, and relay that information to the controller **120**. The stem **115** may be made of ABS plastic or other suitable material. The stem **115** can serve as the interface between the MEI **105** and controller support **125**. The length of stem **115** can be customized based on the residual limb length to mimic the length of the user's non-amputated limb. This mechanism also has the ability to withstand and hold incremental weight, which can be used for training purposes in order to prepare the user for her prosthesis or other assistive device. In an embodiment, a controller **120** may be, for instance, a standard virtual reality controller, such as HTC Vive by HTC Corporation (New Taipei City, Taiwan, <http://www.vive.com>). FIG. 1B shows a representation of an exemplary controller **120**. The controller **120** may be modified with an embedded circuit board **121**. Input signals from the sensors **102** may be relayed through the embedded circuit board **121** and passed to the controller buttons **122** via wires **123** which may be soldered. The controller buttons **122** may comprise one or more physical buttons. A 3.3-volt signal (or signal of other appropriate voltage) can simulate the physical pressing of a controller button **122**. This modification allows an electrical signal produced by contracting muscle (EMG) to engage or disengage a controller button **122** on the controller electronically. The EMG signal is received by at least one sensor **102**, processed by the embedded circuit board **121**, and used to simulate actuation of a controller button **122**. Therefore, a controller button **122** may be triggered either mechanically (through typical interaction with the hand/fingers) or electronically (controlled via EMG and relayed through the embedded circuit board **121**). In other embodiments, the controller buttons may be replaced with other types of actuators, such as physical switches. In other embodiments, the embedded circuit board may be located elsewhere than the controller.

[0034].The controller support **125** may be made of ABS plastic or any other suitable material. In an embodiment, the controller support **125** may be defined by a tube shape. The controller support **125** may hold a controller **120** at an angle, in order to mimic the correct orientation that a non-amputated hand would hold the controller. The wrist strap **130** is a vestige of the controller **120** and may not be needed by the user.

[0035].**FIG. 2** shows an embodiment of the MEI **105** and the MCI module **110**, comprising a control unit **111**, battery **112**, and housing **113**. **FIG. 3** displays a person using an exemplary VR interface **200**. The VR interface **200** may comprise an assistive device, such as VR assistive device **100**. The VR interface may further comprise a VR display **210** that can be viewed by the user while she operates the VR assistive device **100**. In the embodiment shown in **FIG. 3**, the VR display **210** is attached to the user's head. Other virtual reality displays may alternately be used. A display **220** also may be provided, to display the image being shown on the VR display **210** and viewed by the user of the system. The VR interface **200** allows a user with an amputation or other condition requiring a prosthesis, orthosis, or other assistive device to view a series of images that change depending at least in part on the action the user takes to move or otherwise operate the VR assistive device **100**. For instance, the series of images may comprise a video game that is used to train the user in the operation of the VR assistive device **100**. As shown in **FIG. 3**, the display **220** displays the same image that is displayed to the user on the VR display **210**.

[0036].In an embodiment, an arm band **300** may be used in lieu of the VR assistive device **100**. The arm band **300** may comprise one or more sensors **302** provided in a housing **301**. The housing **301** may comprise more than one housing element **304** which may be connected by flexible connectors **303**. The arm band **300** may be wrapped around a residual

limb as shown in **FIG. 5**. The housing elements **304** may be modified to weigh more or less in order to simulate the feeling of the assistive device that has been prescribed for the user. The armband **300** may have a wireless transmitter **306** that allows EMG information received by the sensors **302** to be transmitted wirelessly. The transmitter **306** may also transmit a gesture instruction produced by the myoelectric control interface **308**. **FIG. 6** shows a representation of the arm band **300** comprising sensors **302**, a battery **305**, a transmitter **306**, and a myoelectric control interface **308**. The myoelectric control interface **308** receives the EMG information from the sensors **302** and determines the likely gesture the user was attempting to make, based on user's muscle movement which generates EMG information received by the sensors **302**.

[0037].The arm band **300** may comprise amplification and processing electronics. The electronics may be contained within the housing elements **304**. For instance, a first housing element may contain an amplifier board and a second housing element may contain a processing board. Separate housing elements **304** may contain a battery. One housing element **304** may comprise a ground electrode. The electronics may be used to process EMG signals as is known in the art. The myoelectric control interface **308** is a type of EMG control module **420** (described below). The myoelectric control interface **308** may be defined as a pattern recognition classifier as described in further detail below.

[0038].More generally, **FIG. 7** displays a representation of an interface **400**. The interface **400** may comprise a sensor system **410** that comprises at least one EMG sensor **405**. The sensor system **410** may comprise a physical actuator **406**, such as a button, switch, touch-activated display, or the like. The sensor system **410** may also comprise one or more kinematic sensors **407** for determining the position, velocity, acceleration, or other kinematic characteristic of a portion of a user of the interface **400**, such as the user's limb. Such characteristics may

include, for example, gravitational position, inertial measurement, yaw, pitch, roll, or other kinematic characteristics. The sensor system **410** receives EMG information from a user and transmits it to an EMG control module **420**. The sensor system **410** may additionally comprise amplifiers, filters, and other electronics systems known in the art for processing EMG signals and providing EMG information to a control module. The EMG control module **420** analyzes the EMG information from the sensor system **410** and determines the intended gesture based on the received EMG information. The EMG control module **420** produces gesture instructions to the VR control module **430**. The VR control module **430** receives the gesture instructions and causes the VR display **440** to display a virtual representation of the intended gesture. The actuator **406** may be used to provide information to the VR control module **430**, such as on/off information or general actuation information.

[0039]. The VR control module **430** and the VR display **440** may be part of a VR system **450**. One such system is the VR system described in U.S. Patent App. No. 2016/0162012 A1 to Chang et al, titled *Virtual Reality System and Method for Controlling Operation Modes of Virtual Reality System*, published June 9, 2016 (hereinafter, “Chang”), which is incorporated by reference. The sensor system **410**, EMG control module **420**, and VR control module **430** may each be integrated into its own separate hardware, or one or more of them may be integrated into the same hardware. The VR system **450** may comprise a detector **435** which, in coordination with the kinematic sensor **407**, allows the VR system **450** to detect the kinematics of a portion of the user – for instance, detecting the position of the user’s residual limb. The detector **435** may be, in one embodiment, a base station of the kind described in Chang. In related or alternative embodiments, other forms of virtual reality tracking may be employed, such as inside-out

tracking, markerless inside-out tracking, positional tracking, outside-in tracking, or other virtual reality tracking methodologies known in the art.

[0040]. Using the interface **400**, a user may flex her muscles in a manner that indicates she wishes to perform a gesture, such as wrist rotation. The sensor system **410** receives EMG information from the user and transmits it to the EMG control module **420**. The EMG control module **420** determines that the user intends to perform the wrist rotation gesture. The EMG control module **420** then sends a gesture instruction to the VR control module **430** that instructs the VR control module **430** to generate instructions to rotate a virtual reality wrist displayed on the VR display **440**. The VR display **440** then displays the rotation of the virtual reality wrist, which the user can view. It should be understood that the user may be an amputee, and so even though she is capable of flexing her muscles in a manner indicating a wrist rotation gesture, she does not have a physical wrist. Using the VR display **440** to watch the rotation of the virtual reality wrist can give the user a sensation of having an artificial wrist, even though no artificial wrist is connected to her residual limb. The same is true for other limb gestures, such as wrist flexion, wrist pronation, hand open, no motion, hand closed, wrist supination, wrist extension, wrist abduction, and wrist adduction.

[0041]. “Myoelectric control” refers to the control of an actual device or a virtual reality device (such as the virtual reality wrist described above) using EMG information. Various algorithms may be used to perform myoelectric control. A myoelectric control module may be programmed into an EMG control module **420**. One form of myoelectric control can be termed “*direct control*”. Direct control measures the EMG information over a control site and uses basic signal processing to extract an amplitude feature from the signal, for instance, the mean absolute

value (MAV) or root mean square (RMS) value of the signal. The value of the amplitude feature may then be compared to a preset threshold to determine if the user intends to make a motion.

[0042]. An extension of this type of control, termed ‘direct proportional control’, uses the value of the amplitude feature to control the speed of actuation of the prosthesis, as it is well known that the amplitude features are proportional to intensity of a muscular contraction. Both direct control and direct proportional control strategies are intuitive provided that physiologically appropriate control sites are available from which to measure the EMG.

[0043]. The intuitiveness and number of motion classes of the system is limited by the number of physiologically appropriate control sites available. “*Amplitude multi-state*” myoelectric control is closely related to direct control described above; however, in this case the dynamic range of the amplitude feature is divided into discrete threshold levels. Each of the threshold levels is mapped to an appropriate motion class of the prosthesis. In real-time operation, the extracted amplitude feature is compared to the threshold levels, and the appropriate motion class is actuated.

[0044]. A three-state controller is another amplitude multistate controller. Although it is possible to partition the amplitude range to more than three states, it becomes difficult for the user to control due to the increased cognitive load and the randomness associated with the EMG. The benefits of using multi-state controllers are that more motion classes can be controlled given a limited number of control sites; however, the motion classes may no longer be mapped to physiologically appropriate control sites.

[0045]. Instead of comparing the amplitude feature to a predetermined threshold, the rate of change of the amplitude could also be used for myoelectric control. In this type of control, slowly changing amplitudes corresponding to one motion class while quickly changing

amplitudes corresponds to another. This is sometimes called fast-slow or slow-fast control. After the motion is activated, proportional control is achieved through mapping the actual value of the amplitude feature to the speed of the device. Thus, three-state proportional control can be achieved using this type of rate-sensitive controller. The limitations of this device are similar to the previously mentioned multi-state controllers; the motion classes may not be mapped to physiologically appropriate control sites.

[0046]. Mode switching is another aspect of conventional control. Conventional control systems have historically been limited to a single Degree of Freedom (“DOF”); however, a mode switch may be used to add an additional DOF. An example of conventional control with a mode switch would be a dual site direct control system for a transhumeral amputee. The biceps and triceps muscles may be used to activate elbow flexion and elbow extension respectively. A co-contraction may be used to switch to a hand DOF, after which biceps and triceps muscles would be used to activate hand close and open. The number of co-contractions and the length of time the person must co-contrast can be varied to form a Morse-code like pulsing system. Each pulse sequence then corresponds to a different gesture to control, or hand-grasp pattern to activate. Mechanical switches may be used instead of motion co-contractions to switch between DOFs, and gestures measured through an inertial measurement unit can also be used as a mode-switch.

[0047]. Information extracted from patterns contained in the myoelectric signal can also be used for control purposes. In an embodiment, the EMG control module **420** may be defined as a pattern recognition classifier. Pattern recognition classifiers include but are not limited to modules which use for control one or more of the following algorithms: classification algorithms, clustering algorithms, ensemble learning algorithms, general algorithms for

predicting arbitrarily-structured sets of labels, multilinear subspace learning algorithms, real-valued sequence labeling algorithms, regression algorithms, and sequence labeling algorithms.

[0048]. Classification algorithms or supervised algorithms predicting categorical labels include both parametric and nonparametric algorithms among others. Parametric classification algorithms include but are not limited to linear discriminant analysis, quadratic discriminant analysis, and a maximum entropy classifier, also known as logistic regression or multinomial logistic regression. Nonparametric classification algorithms include but are not limited to decision trees and/or lists, kernel estimation, K-nearest-neighbor algorithms, Naïve Bayes classifier, neural networks (multi-layer perceptrons), perceptrons, support vector machines, and gene expression programming. Clustering algorithms or unsupervised algorithms predicting categorical labels include but are not limited to categorical mixture models, deep learning models, hierarchical clustering (agglomerative and/or divisive), K-means clustering, correlation clustering, and Kernel principal component analysis (“Kernel PCA”). Ensemble learning algorithms or supervised meta-algorithms for combining multiple learning algorithms together include but are not limited to boosting (meta-algorithm), bootstrap aggregating (bagging), ensemble averaging, mixture of experts/hierarchical mixture of experts, and random forest. General algorithms for predicting arbitrarily-structured sets of labels include but are not limited to Bayesian networks and Markov random fields. Multilinear subspace learning algorithms -- one of the uses of which is to predict labels of multidimensional data using tensor representations -- can be categorized in one way as unsupervised and include among others, multilinear principal component analysis (MPCA). Real-valued sequence labeling algorithms -- one use of which predicts sequences of real-valued labels -- can be categorized in one way as supervised and include, among others, Kalman filters and particle filters. Regression algorithms, which can be

used to predict real-valued labels, can be categorized as either supervised or unsupervised. Supervised regression algorithms include but are not limited to Gaussian process regression (kriging), linear regression and extensions, and neural networks and deep learning methods. Unsupervised regression algorithms include, but are not limited to, independent component analysis (ICA) and principal components analysis (PCA). Sequence labeling algorithms which can be used to predict sequences of categorical labels, also include supervised and unsupervised categories. Supervised sequence labeling algorithms include, among others, conditional random fields (CRFs), hidden Markov models (HMMs), maximum entropy Markov models (MEMMs), and recurrent neural networks. Unsupervised sequence labeling algorithms include, but are not limited to, hidden Markov models (HMMs).

[0049]. Pattern recognition control operates on the assumption that at a given electrode location, the set of features describing the myoelectric signal will be repeatable for a given state of muscle activation and will be different from one state of activation to another. In pattern recognition control, the EMG signals may be represented using features, which are statistical descriptions of the signal. Non-inclusive but commonly used examples of features include the amplitude of the signal, the variance of the signal, the number of time the signal crosses zero, the short-time Fourier transform coefficients, wavelet coefficients, auto-regressive coefficients, and the Willison amplitude. These features across all movements may then be learned using machine learning techniques. Examples of commonly used learning algorithms include expectation maximum, gradient descent with back-propagation, or linear/non-linear regression. After the model has been learned, EMG signals are classified in real-time using the mathematical model. Examples of commonly used models include artificial neural networks, linear discriminant

analysis, support-vector machines, quadratic discriminant analysis and Gaussian-Mixture models.

[0050]. Regardless of what type of myoelectric control is used, the objective is to determine what gesture the user is intending to perform. In an embodiment, the EMG control module **420** can perform one or more of the previously listed algorithms, and alternatively can be programmed with new algorithms as they become available.

[0051]. In an embodiment, ten features of time domain and auto-regression are extracted from the EMG information received by sensors **405**. The time domain features include mean relative value; waveform vertical length; zero crossing; and slope change. The remaining features are auto-regression features. In an embodiment using a six-channel EMG sensor system and 200ms windows of EMG data, the raw EMG data per window will be contained in a matrix of six columns by 200 rows, or 1200 elements in size. Each feature will be calculated for each EMG channel (ten features * six channels = 60), so the 6x200 matrix is reduced to a 60x1 vector. This vector is then provided as an input to the EMG control module **420** when defined as a pattern recognition classifier.

[0052]. Still with respect to **FIG. 7**, when the EMG control module **420** is defined as a pattern recognition classifier, the EMG control module **420** may require pattern recognition training in order to accurately determine the user's intended gesture.

[0053]. As shown in **FIG. 12**, the EMG control module **420** may be provided on computer-readable media **504**, such as memory. The computer-readable media **504** may also comprise an operating system **505** for operation of an EMG controller **500**. The EMG controller **500** may comprise one or more processing units **501** for processing the EMG control module

420, as well as an amplifier **502** and a filter **503** for amplifying and filtering EMG signals from sensors **405**.

[0054]. In an embodiment, the EMG control module **420** may be trained using aspects of the VR system **450**. **FIGS. 8-9** show images that may be displayed on the VR display **440** during training of the EMG control module **420**. **FIG. 8** shows a three-dimensional VR space **800** comprising a back wall **805**, a side wall **810**, and a ceiling **815**. Positioned on the back wall **805** are shown a series of interactive columns, with each column representing information about a particular gesture to be trained. The top of each column at **816** identifies the name of the gesture to be trained (wrist flexion, wrist pronation, hand open, no motion, hand closed, wrist supination, and wrist extension). Below each name at **817** is a number that identifies the number of times the respective gesture has been trained. Next is a number and an image at **818** that indicates the portion of the most recent training session that has been completed. The image may have a color, such as green, when the EMG control module **420** is being trained with the respective gesture. Next at **819** is an image of the gesture the user is intended to perform, which may be superimposed by a check mark if the training has been complete. For instance, the image to the farthest left in **819** shows the “wrist flexion” gesture, displaying a hand in a no motion position and a hand in a wrist flexion position. This helps the user visualize the intended gesture to make. At **821** an start/stop button is displayed which allows the user to activate a training session for a respective gesture. For instance, the button to the farthest left in **821** may be selected in order to start a training session for the wrist flexion gesture and to stop an ongoing training session for the wrist flexion gesture.

[0055]. **FIG. 9** shows a representation of the VR space **800** which further includes a virtual limb **850** comprising a forearm **830** and a hand **840**. In order to select a button in **821**, the

user moves her real-life limb. The sensor system **410** detects the movement of the user's real-life limb and sends corresponding information to the VR system **450** to cause a corresponding gesture of the virtual limb **850**. In this way, the motion of the virtual limb **850** can be positioned to point to one of the start/stop buttons in **821**. A trace line, such as a dashed line, may extend from the tips of the fingers of the hand **840** towards the back wall **805**. When the virtual limb **850** is positioned so that the tips of the fingers of hand **840** are pointed at a start/stop button in **821**, the trace line may change color (such as from red to green) and the start/stop button in **821** may also change color (such as from red to green). At that time, the user or clinician may initiate a training phase for the respective gesture, such as by actuating the actuator **406**.

[0056].The EMG control module **420** begins to train based on the EMG information provided by the sensor system **410**. In an embodiment, the EMG control module **420** is defined as a linear discriminant analysis (LDA) pattern recognition classifier. In this embodiment, the control module **420** is arranged with gesture classes **421**. Each class in gesture class **421** may be correlated with exactly one degree of freedom movement. In an embodiment, the gesture classes **421** comprise one class for each of wrist flexion, wrist pronation, hand open, no motion, hand closed, wrist supination, wrist extension, wrist abduction, and wrist adduction.

[0057].For example, when the start/stop button in **821** associated with the no motion gesture is actuated, the user is instructed to hold her residual limb in a fixed position without exerting any muscles that would indicate one of the other gestures. The sensor system **410** detects the EMG signals from the user's forearm and sends EMG information to the EMG control module **420**, which now is in a training state. The EMG control module **420** associates the incoming EMG information with a "no motion" class for the duration of the "no motion" training. The "no motion" training period may be for a specified duration, such as 2-3 seconds

or another appropriate time. During the “no motion” training period, the position of the forearm will move if the user moves her residual limb. Likewise, during a training period, the position and orientation of the hand **840** will move as the user actuates her muscles in a manner intended to move the hand **840** to match the respective gesture **816**.

[0058]. At the completion of the “no motion” training, the EMG control module **420** completes the training state. The user is then able to select another gesture category to train on, or to re-train the “no motion” category again. In each training session, the EMG control module **420** enters a training state in which the EMG control module **420** is trained to the gesture category selected by the user. In this way, the user may train each class in gesture classes **421** with EMG information that corresponds to the user’s movements conducted during a training session. Feature extraction and classification may be performed in real-time, which can allow the user to test the classifier’s performance following each collected set of training data.

[0059]. Still with respect to **FIG. 8**, buttons reset **825** and DNT **826** are shown positioned on the back wall **805**. Reset **825** resets the training data stored in the EMG control module **420** and the gesture classes **421**, so that the EMG control module reverts to an untrained state. DNT **826** allows the interface **400** to collect EMG information collected by the sensor system **410** but not include that information in training data. One purpose of the DNT feature (which stands for “do not train”) is so that the collected data can be used in offline analysis to determine overall algorithm efficiency and to determine classifier effectiveness.

[0060]. In an embodiment, the hand **840** may start a training session in a semi-closed position, so it has room to open or close. The speed of the movement of hand **840** may depend on information provided by kinematic sensors **407**. For instance, the kinematic sensors **407** may provide a proportional control value to regulate the speed of movement of the hand **840**. In an

embodiment, the kinematic sensors **407** provide a value between 0 and 1 to the VR control module **430** which reflects the speed of intended hand movement. If the value is closer to 0, the hand movement is correspondingly slow. If the value is closer to 1, the hand movement is correspondingly fast. In another embodiment, the speed of the movement of the hand **840** may depend on a measurement of the EMG signal provided by the user. For instance, a strong EMG signal may result in a proportional control value that makes the hand move quickly and a weak EMG signal may result in a proportional control value that makes the hand move slowly. Hand and wrist gestures may be independent. For instance, if the hand is set in a “hand closed” position, and wrist flexion is then trained, the VR display **440** will display the wrist flexing while the hand remains in a hand closed position.

[0061]. The EMG control module **420** may provide a vector of size n to the VR control module **430**, where n is equal to the number of classes in gesture classes **421**. Each value in the vector may be +1, 0, or -1. +1 in position i reflects a movement in one direction for class i . For instance, if the vector has a value of +1 at position 5, which may be the hand open/close gesture position, this can instruct the VR control module to close the hand **840**. If the vector has a value of -1 at position 5, which may be the hand open/close gesture position, this can instruct the VR control module to open the hand **840**. As another example, if the vector has a value of -1 at position 6, which may be the wrist flexion / extension gesture position, this can instruct the VR control module to flex the wrist **830**. If the vector has a value of +1 at position 6, which may be the wrist flexion / extension gesture position, this can instruct the VR control module to extend the wrist **830**.

[0062]. There are various ways to instruct a user to position her residual limb during training. In an embodiment, the type of training described above with reference to **FIGS. 8-9** is

conducted while the user keeps her residual limb in a fixed position, while during the different training phases actuates different muscles intended to reflect desired hand or wrist gestures. For instance, the user may keep her arm in a single orientation, with the residual limb parallel to the floor and the elbow at a 90° angle, while collecting training data on each of the movements. The user's upper-arm may remain parallel and against her body and remain still during the training period. This type of training may be referred to as "static training."

[0063]. Static training may be supplemented by, or in some embodiments replaced with, training in which the user moves her residual limb in real-life in three dimensions – in front of / behind her; to her left / right; and above / below her. In this type of training exercise, referred to as "dynamic training," a user may move her residual limb, unconstrained, around her body while performing each gesture in the gesture class **421**. A user can be encouraged to extend/flex her elbow or move her residual limb into a variety of orientations, such as pointing the residual limb upwards towards the real-life ceiling or downwards towards the real-life floor.

[0064]. One exemplary method for conducting dynamic training is referred to herein as "target achievement control," in which the user moves her residual limb to cause a virtual limb to point to a virtual target in a virtual three-dimensional space. **FIG. 10** shows an image of a virtual target **610** in a virtual three-dimensional space **600** displayed on a VR display **440**. The virtual limb **850** shown in **FIGS. 8-9** may be replaced with a "limb avatar," which is a virtual representation of the user's real-life limb. As shown in **FIG. 10**, the limb avatar takes the form of a crossbow **620**. As the user moves her muscles, the interface **400** detects the movement as described above and causes the crossbow **620** to make a corresponding movement within the space **600**. The user may stand facing a single direction, or stand but move her head to look around the space **600**, in order to look for a virtual target **610**. The virtual target **610** may

pseudo-randomly appear in one of a plurality of discrete positions at a time. As shown in **FIG. 13**, from the user's perspective, a virtual target **610** could appear, for example, in one of four horizontal positions (two on either side), and four vertical positions, with some appearing above the user and some appearing below. In target achievement control training, once the user has pointed the crossbow **620** to a virtual target, such as target **610**, the user contracts her muscles in a manner to reflect an intended gesture.

[0065]. To give a non-limiting example, the user may contract her muscles in a manner to reflect an intended gesture shown on the virtual target **610**, such as a "hand close" gesture. The sensor system **410** detects the EMG signals from the user's forearm and sends EMG information to the EMG control module **420**, which again is in a training state. The EMG control module **420** associates the incoming EMG information with a "hand close" class for as long as the user is shooting the virtual target **610**. Once the user has stopped shooting the virtual target **610**, the EMG control module **420** completes the training state. The user is then able to select another target to shoot, which is associated with the same or a different gesture. The process is repeated as needed to train EMG control module **420**. In each shooting session, the EMG control module **420** enters a training state in which the EMG control module **420** is trained to the gesture category associated with the virtual target. In this way, the user may train each class in gesture classes **421** with EMG information that corresponds to the user's movements conducted during a training session specific to the associated gesture category. One feature of this type of dynamic training is that each gesture class in the gesture classes **421** may be trained with EMG information generated while the user's residual limb is at different orientations. With reference again to **FIG. 13**, the user must reach her residual limb upward to target a virtual target above her head, and must lower her residual limb downward to target a virtual target below her head.

Raising and lowering the residual limb activates different muscles at different intensities, which changes the nature of the EMG signals produced by the user's muscles. However, training data remains categorized within each gesture class. As a result, training data from the user making a "hand close" gesture at a low target, training data from the user making a "hand close" gesture at a mid-level target, and training data from the user making a "hand close" gesture at a high target are all used to train the same "hand close" class in the gesture classes **421**. Although the prior description is with reference to the "hand close" gesture, the description above equally applies to the other gesture classes available in the system.

[0066]. The virtual target **610** may take many visual forms. For instance, restricting the user from seeing the associated gesture of the virtual target **610** until the crossbow **620** points at the virtual target **610** may help the user from pre-emptively shooting before the crossbow **620** is in the proper position. Furthermore, the user can be encouraged to avoid firing arrows from the crossbow **620** when moving between cubes, to assist in improving control. Fired arrows may be colored with a color that represents the gesture being performed (such as blue for "hand closed", orange for "hand open", and the like). When the user was not pointing the crossbow **620** at a virtual target **610**, a non-gesture image (like the image of a stop sign) may be shown. Once the user pointed the crossbow **620** at the virtual target **610**, the gesture associated with the virtual target may be shown on an outer surface of the virtual target **610** or in proximity to the virtual target **610**, or otherwise displayed on the VR display **440**. Alternately the associated gesture may be announced audibly to the user. Once the crossbow **620** is pointed at the virtual target **610**, the user may perform the associated gesture. The EMG control module **430** may determine whether the user has successfully performed the associated gesture, and send a gesture instruction to the VR control module **430** indicating whether or not the user has

successfully performed the associated gesture. If the user has successfully performed the associated gesture, this may cause the virtual target **610** to transform. In an embodiment, the virtual target **610** may grow in size until it “breaks” visually. In an embodiment, each arrow fired represents one window of EMG data, therefore, arrows are fired every 25 ms, for example, and the threshold to break a virtual target **610** may be set to 100 arrows for example. A virtual target **610** may be designed so that it increases in size only if the correct arrow color (which reflects the correct estimated gesture from the user’s EMG information) matches the gesture associated with the virtual target **610**. However, incorrect estimated gesture information may still be used in adaptation. This can be used as feedback to the user, so she is aware of her progress over time.

[0067]. In another embodiment, the virtual target **610** may disappear at a set time, starting from the first time the crossbow **620** is pointed to it. For instance, the virtual target **610** may disappear after three seconds after the crossbow is pointed to it. If the user “fires” all the correct arrows from the moment she points at the virtual target **610**, it would take 2.5 seconds (25 ms windows * 100 arrows) to break the virtual target **610**, indicating a success. A success sound may be presented to the user once the virtual target **610** breaks. If the user is unable to destroy the virtual target **610** within the time limit, the virtual target **610** may disappear, and the next virtual target can appear at another location. A different sound may be presented to the user to indicate a failed attempt at breaking the virtual target **610**. This again may be used as feedback for the user.

[0068]. The EMG control module **420** can be programmed to send gesture instructions to the VR control module **430**. Each output movement can be mapped to a button on a commercially available VR controller, such as controller **120**. The outputs can be sent over a

wired connection to the controller **120**. For example, rather than pressing a button on a controller in order to accelerate a vehicle in a video game as an able-bodied individual would do while playing a game, an amputee can contract a muscle which mimics that button press to perform the same action. The EMG control module **420** can also communicate directly to the control module **430** using a wireless link. For example, a TCP/IP connection can be established to the VR system **450**. In this situation, the VR system **450** may comprise wireless means known in the art. Gesture instructions from the EMG control module **420** can be programmed to emulate controls from a directional pad (DPAD) game controller and button clicks from controller buttons. Thus any virtual reality game that uses a controller with an actuator can be emulated.

[0069]. As described earlier, EMG signals can be detected from an amputee's residual limb and are converted into video game control signals by the EMG control module **420**. The EMG control module **420** can perform various clinically available EMG control paradigms. The VR system **450** can utilize therapist-defined rehabilitation protocols to customize the game controls and environment. The VR system **450** can collect and report patient performance metrics back to the clinician, which can help the clinician progress and optimize protocols to achieve the patient's functional rehabilitative goals. For example, a clinician may create an initial gameplay profile that may rely on mastery of a limited or specified set of contractions made by the user. Once a certain level of mastery of these clinician-defined metrics is achieved, the gameplay may progress to require the user to make additional contractions, until the required level of neuromuscular control is achieved. Monitoring of a user's performance as well as the adjustment of rehabilitation protocols used for gameplay may be done in real time either on site, or remotely via an internet connection. Such a design lends itself to ongoing telemedical

interactions to allow protocol progression and allows for adaptation of the system as the patient's abilities change or she upgrades her assistive device or associated components.

[0070]. In another embodiment, a user must target and shoot falling balloons of different colors. The user moves the orientation and position of her residual limb to change where the limb avatar is pointed. When she has positioned the limb avatar appropriately, she can make a muscle contraction to shoot a bullet or laser-beam to burst the balloon. The different colors of the balloons correspond to different muscle contractions that would be used as part of the myoelectric control interface, and changes in size are based on performing the correct action. Colors and the corresponding actions are shown at the bottom of the screen so the user can learn which color corresponds with which action. As a balloon falls, the user must recognize the color of the balloon and match a specific movement to shoot the balloon and gain points (if the balloon hits the ground no points are awarded). When a contraction is made, the color of the bullets will also correspond to the muscle contraction. For example, when a user sees a green balloon, green bullets will appear if the person performs the correct gesture with her residual limb. The user may shoot a target balloon multiple times to make it expand, until it bursts, if she has performed the correct action. A user's score can increase in inverse proportion to the time taken to explode the balloon. The user's score may increase or decrease depending on the size and position of the balloon. If a user performs the incorrect movement and a different color bullet (representing a different gesture) hits the balloon, their score may decrease. The score may be saved locally or uploaded to a central server.

[0071]. A user can progress to a different level by changing the speed or size at which targets appear in the game play environment. When using a VR control system **450**, the virtual targets can be placed in different areas of the game space so that the user has to move to a

different position and place their limb in a different orientation and position to successfully burst the target. Weights can also be added to the sensor system **410** or to the user's arm, to simulate the weight of a prosthetic device. Weights may be added incrementally as the individual progresses through her rehabilitation protocol. The application of weights may be used with any game played in the VR system **450**. In another embodiment, to promote bimanual activities, a cross-hair target can be controlled using the user's sound limb. When a user has placed the target properly, they can use their affected limb to shoot at the target.

[**0072**]. In another game, a user holds a simulated pump-action shotgun using the VR controller. The user's relative orientation between the two controllers, which are either being held or attached to the user, may be used to aim the shotgun, and the relative motion between the two controllers may be used to initiate the pump-action gun to reload. The user then can make an muscle contraction to pull the trigger to shoot the gun. Targets can appear anywhere in the game to encourage the user to move positions and limb orientations.

[**0073**]. After the EMG control module **420** has been trained, the VR system **450** can create a virtual environment in which the user attempts to make specified gestures of a virtual limb. **FIGS. 11A-C** show an example of such a virtual environment. **FIG. 11A** displays a limb avatar **710** in a virtual space **705**. The limb avatar **710** moves its forearm, wrist, and fingers in response to EMG information and optionally in response to kinematic information. **FIG. 11B** additionally displays a target position **720**. The goal of the game displayed in **FIGS. 11A-C** is for the user to move her muscles in such a way as to cause the limb avatar **710** to match the same position as the target position **720**. If the user successfully matches the limb avatar **710** to the position of the target position, shown in **FIG. 11C**, the VR system **750** may provide positive

feedback to the user. For instance, the color of the outer surface of the limb avatar **710** may change; a positive feedback sound may be played; or other positive feedback may be provided.

[0074]. In an embodiment, the virtual environment shown on VR display **440** may comprise an instruction mechanism, such as a virtual coach, that instructs the user in making appropriate movements of her residual limb. For instance, the instructions can guide the user to slow down if she is moving her residual arm too quickly during dynamic training. Likewise, when a user performs dynamic training, a user tends to rotate their limb while making a hand open or hand close movement. The instructions would detect that the user is rotating her limb and provide an instruction to the user to stop rotation. In another example, a user may make muscle contractions that are too strong or too loose. The instructions can instruct the user in the proper contraction strength, and have the user perform a range of contraction strengths. The instructions could be given in words or pictures displayed on the VR display **440**, could be provided audibly or with haptic feedback to the user, or could be given by an avatar “virtual coach” displayed on the VR display **440**.

[0075]. In other embodiments, the interface **400** could be revised so that the VR system **450** is replaced with a two-dimensional visual display, such as a computer display. Examples of computers could include desktop computers, laptop computers, smartphones, tablets, and the like. The VR control module **430** could be replaced with a two-dimensional control module programmed to convert gesture instructions from the EMG control module **420** into control commands for programs operating on a computer display, such as Tetris or Pac-Man.

[0076]. Once the EMG control module **420** has been trained, it may be arranged for use with a real-life assistive device **460**. The assistive device **460** may be a myoelectric device, such as a myoelectric prosthetic arm. One aspect of using a trained EMG control module **420** to

operate the assistive device **460** is that the EMG control module **420** is trained to identify the gestures the user wishes to make. The EMG control module **420** can provide a gesture instruction to the assistive device **460**, and the assistive device **460** will make the intended gesture. Examples of myoelectric assistive devices may include, but are not limited to the U3+ Arm from Motion Control, Inc. (Salt Lake City, UT), the bebionic hand from Otto Bock (Austin, TX), or the assistive device described in U.S. Patent Publication No. 2015/0216681 A1, Modular and Lightweight Myoelectric Prosthesis Components and Related Methods (published August 6, 2015), which is incorporated herein by reference.

[0077]. The virtual reality environment displayed by VR display **440** may be generated using the Unity virtual reality platform by Unity Technologies (San Francisco, CA). The virtual reality limbs may be generated by software for modelling 3-dimensional humanoid characters, such as MakeHuman by the MakeHuman Team (www.makehuman.org). The limb model may be comprised as a plurality of joint representations. The wrist representation may have three degrees of freedom (for wrist rotation, wrist flexion/extension, and wrist adduction/abduction) and each finger joint representation may have a single degree of freedom (for opening or closing the hand).

[0078]. The embodiments described herein provide several advantages for individuals who use myoelectric arm prostheses or other assistive devices. Such advantages, in addition to those already described, include: work toward more accurate programming of the assistive device specified for particular users to encourage more efficient and effective transition to an assistive device; facilitating motor practice and improvements in assistive device control independently of the user's assistive device brand or type; having monitoring and diagnostic capabilities to optimize treatment strategies and sequence of progression throughout the

rehabilitation process; simulating the weight and inertia of an assistive device; promoting training during bimanual activities; promoting work within the myoelectric workspace; able to be used by the user at her home following an initial tuning session at a clinic.

[0079]. Although the techniques have been described in language specific to structural features and/or methodological acts, it is to be understood that the appended claims are not necessarily limited to the features or acts described. Rather, the features and acts are described as example implementations of such techniques. Female pronoun references to users of the system should be understood to apply to both male and female users of the system.

[0080]. The operations of the example processes are illustrated in individual blocks and summarized with reference to those blocks. The processes are illustrated as logical flows of blocks, each block of which can represent one or more operations that can be implemented in hardware, software, or a combination thereof. In the context of software, the operations represent computer-executable instructions stored on one or more computer-readable media that, when executed by one or more processors, enable the one or more processors to perform the recited operations. Generally, computer-executable instructions include routines, programs, objects, modules, components, data structures, and the like that perform particular functions or implement particular abstract data types. The order in which the operations are described is not intended to be construed as a limitation, and any number of the described operations can be executed in any order, combined in any order, subdivided into multiple sub-operations, and/or executed in parallel to implement the described processes. The described processes can be performed by resources associated with one or more device(s) such as one or more internal or external CPUs or GPUs, and/or one or more pieces of hardware logic such as FPGAs, DSPs, or other types of accelerators.

[0081]. All of the methods and processes described above may be embodied in, and fully automated via, software code modules executed by one or more general purpose computers or processors. The code modules may be stored in any type of computer-readable storage medium or other computer storage device. Some or all of the methods may alternatively be embodied in specialized computer hardware.

[0082]. Conditional language such as, among others, “can,” “could,” “might” or “may,” unless specifically stated otherwise, are understood within the context to present that certain examples include, while other examples do not include, certain features, elements and/or steps. Thus, such conditional language is not generally intended to imply that certain features, elements and/or steps are in any way required for one or more examples or that one or more examples necessarily include logic for deciding, with or without user input or prompting, whether certain features, elements and/or steps are included or are to be performed in any particular example. Conjunctive language such as the phrase “at least one of X, Y or Z,” unless specifically stated otherwise, is to be understood to present that an item, term, etc. may be either X, Y, or Z, or a combination thereof.

[0083]. Any routine descriptions, elements or blocks in the flow diagrams described herein and/or depicted in the attached figures should be understood as potentially representing modules, segments, or streams of code that include one or more executable instructions for implementing specific logical functions or elements in the routine. Alternate implementations are included within the scope of the examples described herein in which elements or functions may be deleted, or executed out of order from that shown or discussed, including substantially synchronously or in reverse order, depending on the functionality involved as would be understood by those skilled in the art. It should be emphasized that many variations and

modifications may be made to the above-described examples, the elements of which are to be understood as being among other acceptable examples. All such modifications and variations are intended to be included herein within the scope of this disclosure and protected by the following claims.

CLAIMS

What is claimed is:

1. An apparatus comprising an electromyographic (EMG) control module configured to:
 - receive EMG information generated by an individual in response to a virtual reality display indicating a gesture class;
 - train using the received EMG information and the gesture class; and
 - after training, operate an assistive device.
2. The apparatus of claim 1, wherein the EMG control module is further configured to:
 - determine an intended gesture based on the EMG information; and
 - output a gesture instruction associated with the intended gesture.
3. The apparatus of claim 1, further comprising a sensor system, the sensor system comprising:
 - a kinematic actuator for providing kinematic information about the individual to a virtual reality control module.
4. The apparatus of claim 2, wherein the gesture instruction is defined as a scalar value.
5. The apparatus of claim 2 wherein, in response to the gesture instruction, the virtual reality display displays a virtual limb in a position reflecting the intended gesture.
6. The apparatus of claim 3, wherein, in response to the gesture instruction, the virtual reality display shows a trace line originating at a limb avatar and terminating at a virtual target.
7. The apparatus of claim 5, wherein an image representing the intended gesture is displayed on the virtual target.
8. The apparatus of claim 1, wherein the EMG control module is defined as a pattern recognition classifier.

9. The apparatus of claim 8, wherein the EMG control module comprises a plurality of gesture classes.
10. The apparatus of claim 8, wherein the gesture classes comprise a hand open class, a hand close class, a no motion class, a wrist rotation class, and a wrist extension/flexion class.
11. The apparatus of claim 1, wherein the EMG signals generated by the individual are generated by the individual's limb moving in more than one physical dimension.
12. The apparatus of claim 11, wherein the EMG signals generated by the individual are generated by the individual's limb moving in three physical dimensions.
13. The apparatus of claim 2, wherein the virtual limb is displayed as a shooting device.
14. The apparatus of claim 1, wherein the virtual reality display is configured to display a virtual target.
15. The apparatus of claim 5, wherein the virtual reality display is configured to display a virtual target and the virtual target disappears if the virtual limb is not pointed at the virtual target after a predetermined period of time.
16. An apparatus comprising an electromyographic (EMG) control module defined as a pattern recognition classifier, the EMG control module configured to:
 - receive EMG information generated by movement of an individual's limb in more than one physical dimension in response to a virtual reality display indicating a gesture class; and
 - train using the received EMG information and the gesture class.wherein each class in the classifier is trained using EMG information received from user movement in more than one physical dimension.

1/11

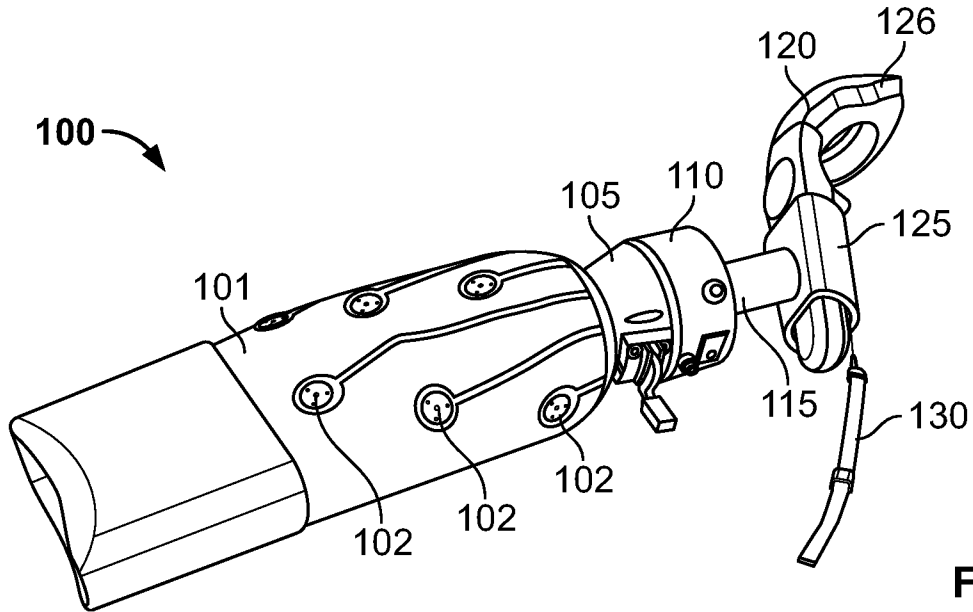

FIG. 1A

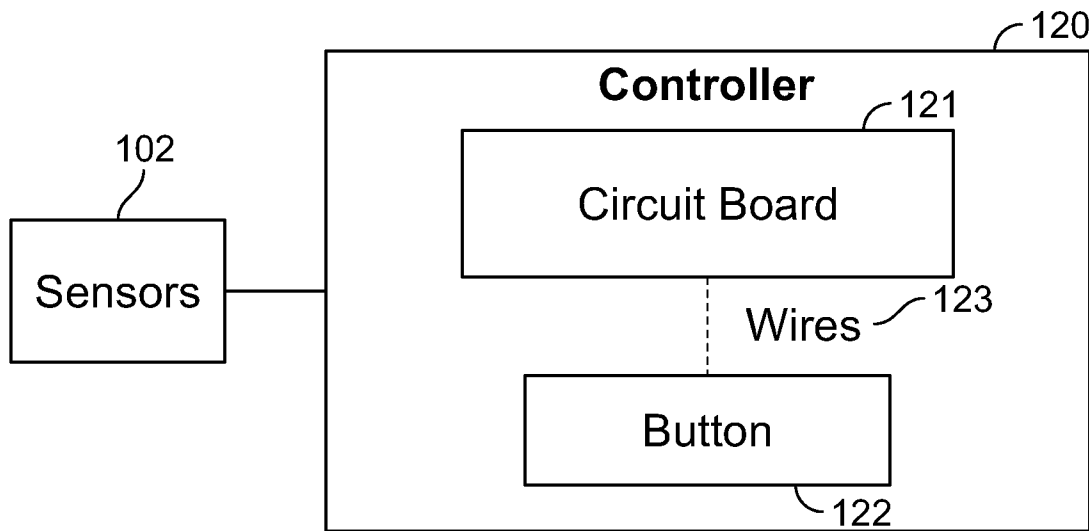

FIG. 1B

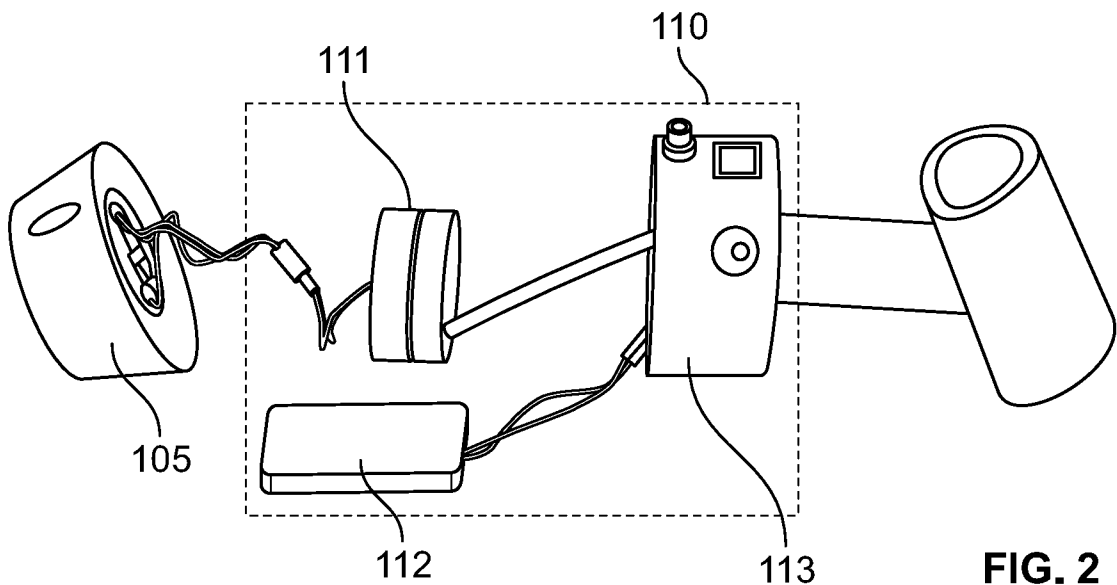

FIG. 2

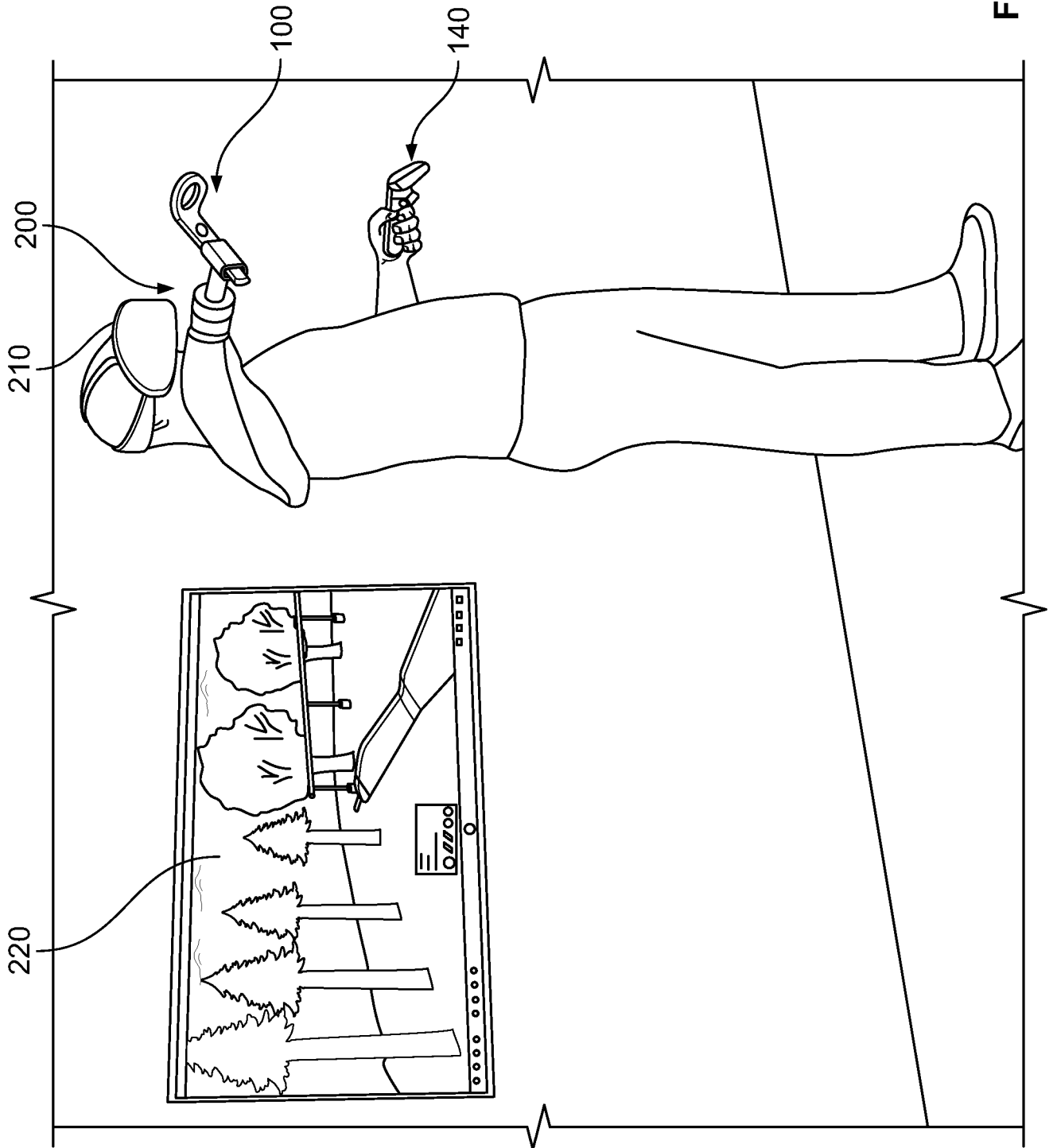

FIG. 3

3/11

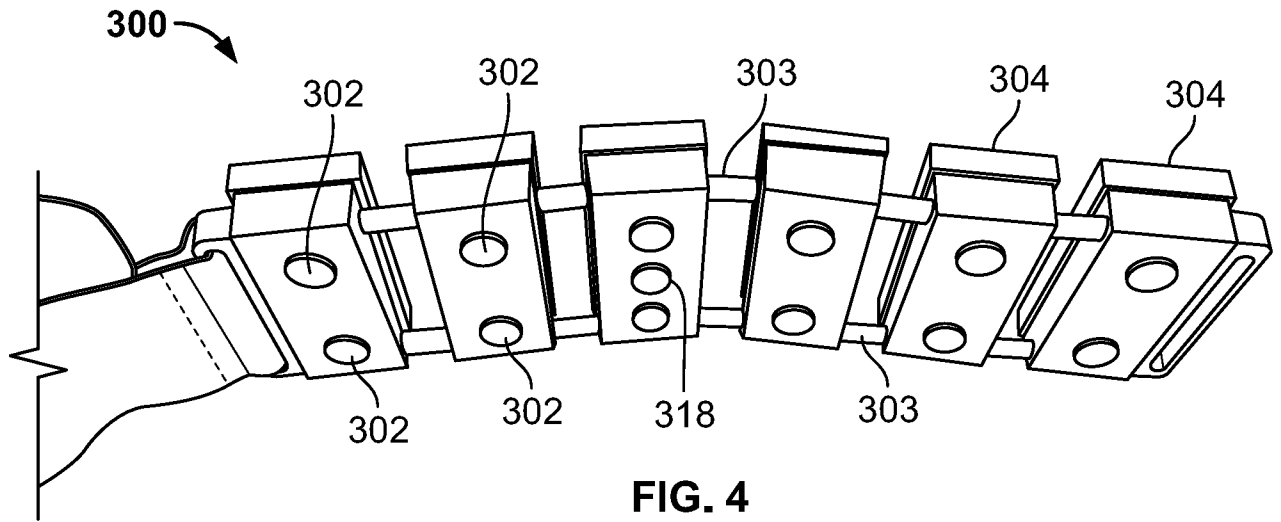

FIG. 4

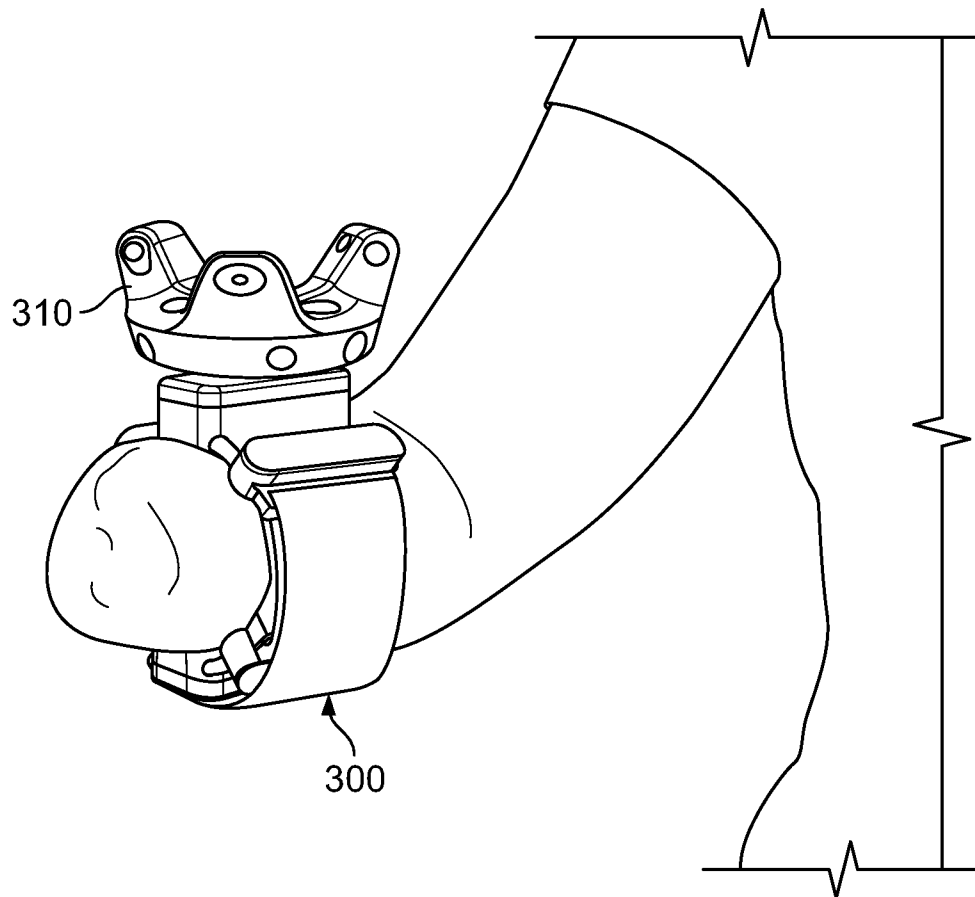

FIG. 5

4/11

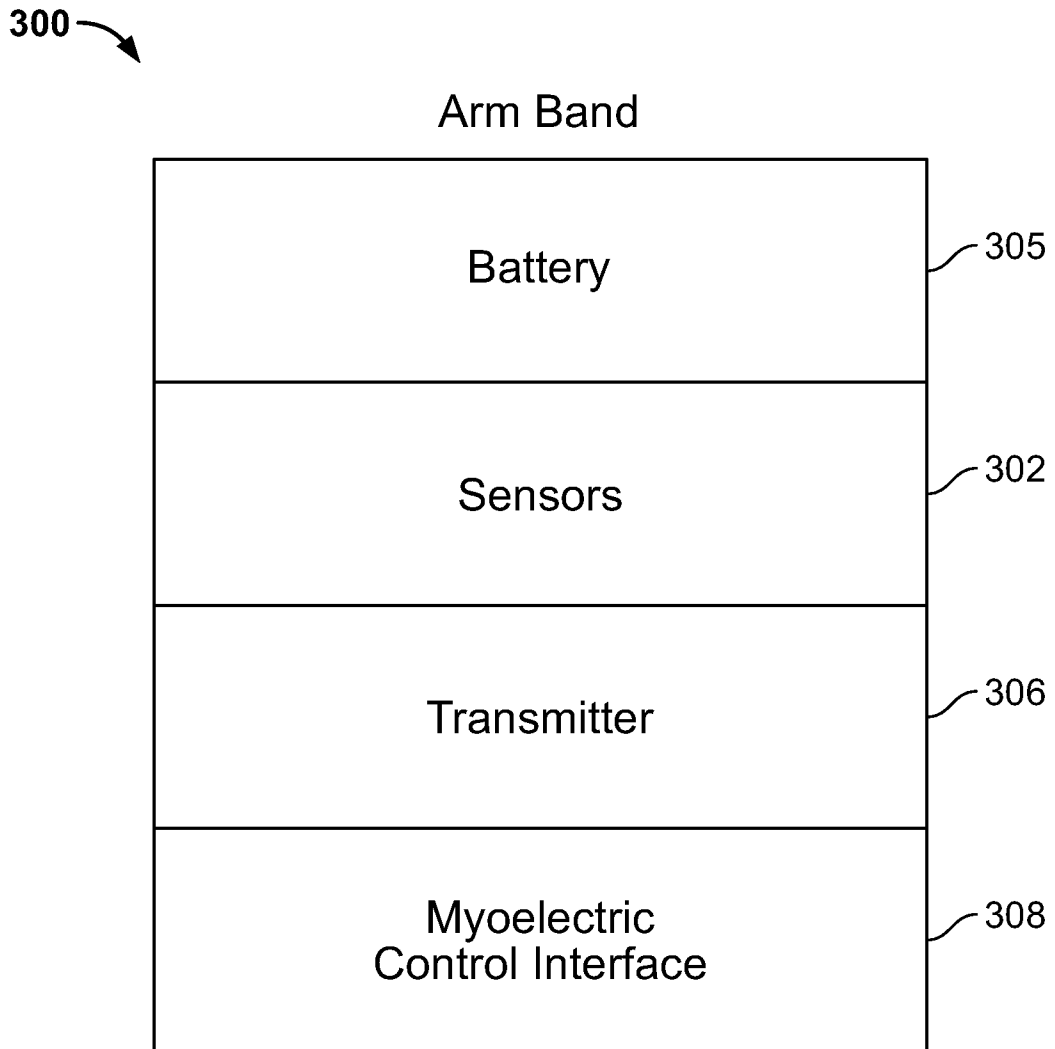

FIG. 6

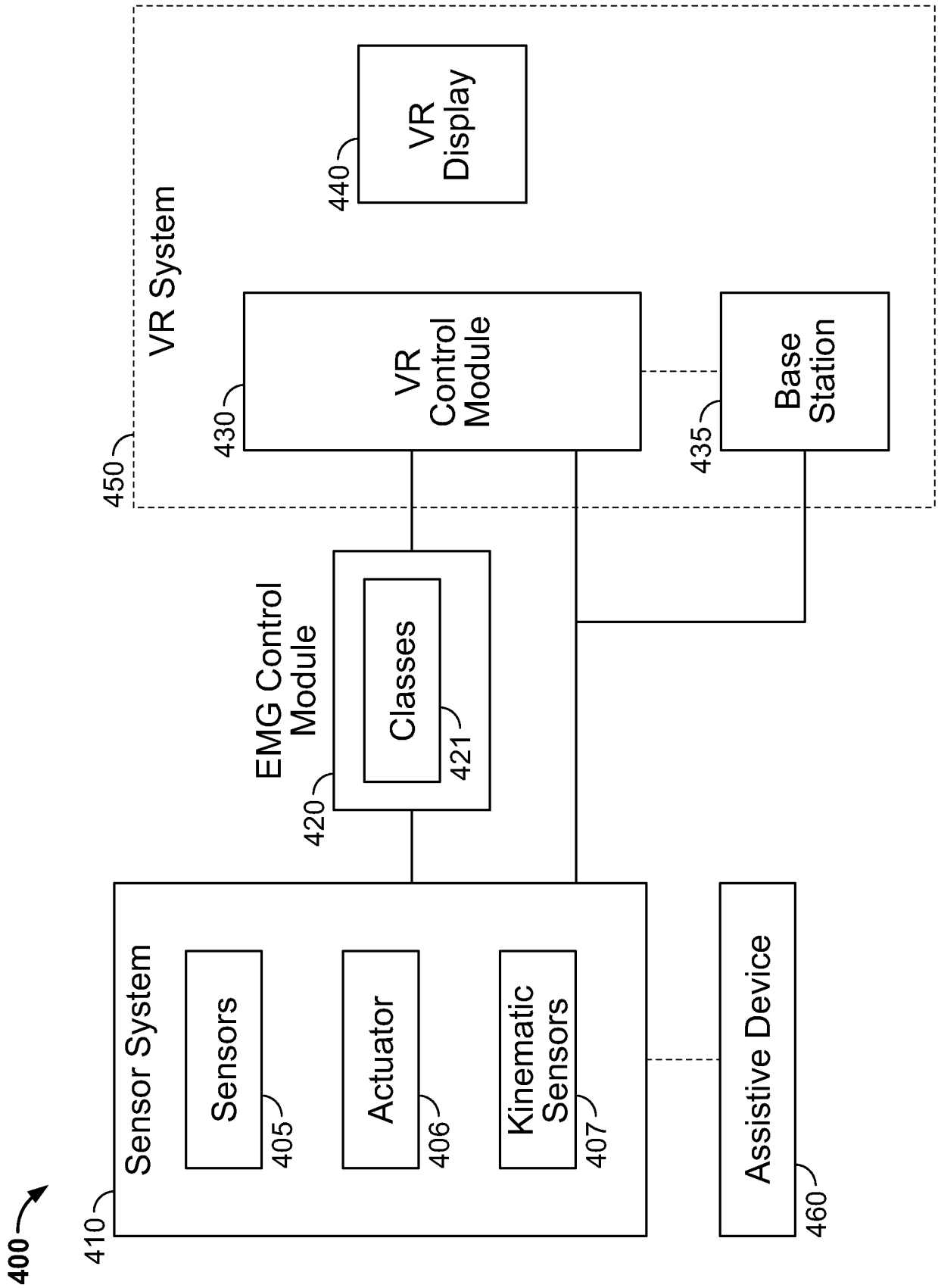

FIG. 7

6/11

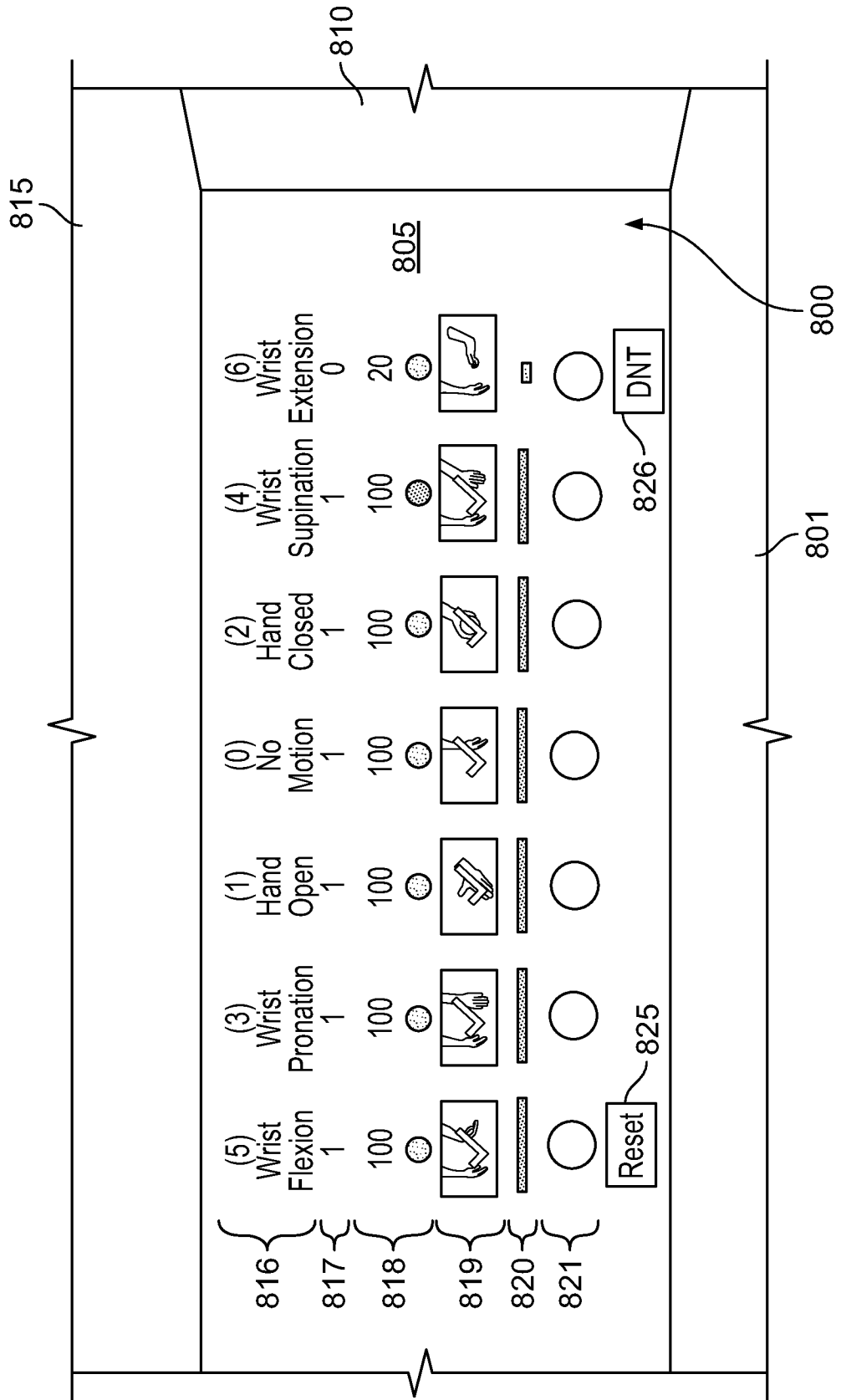

FIG. 8

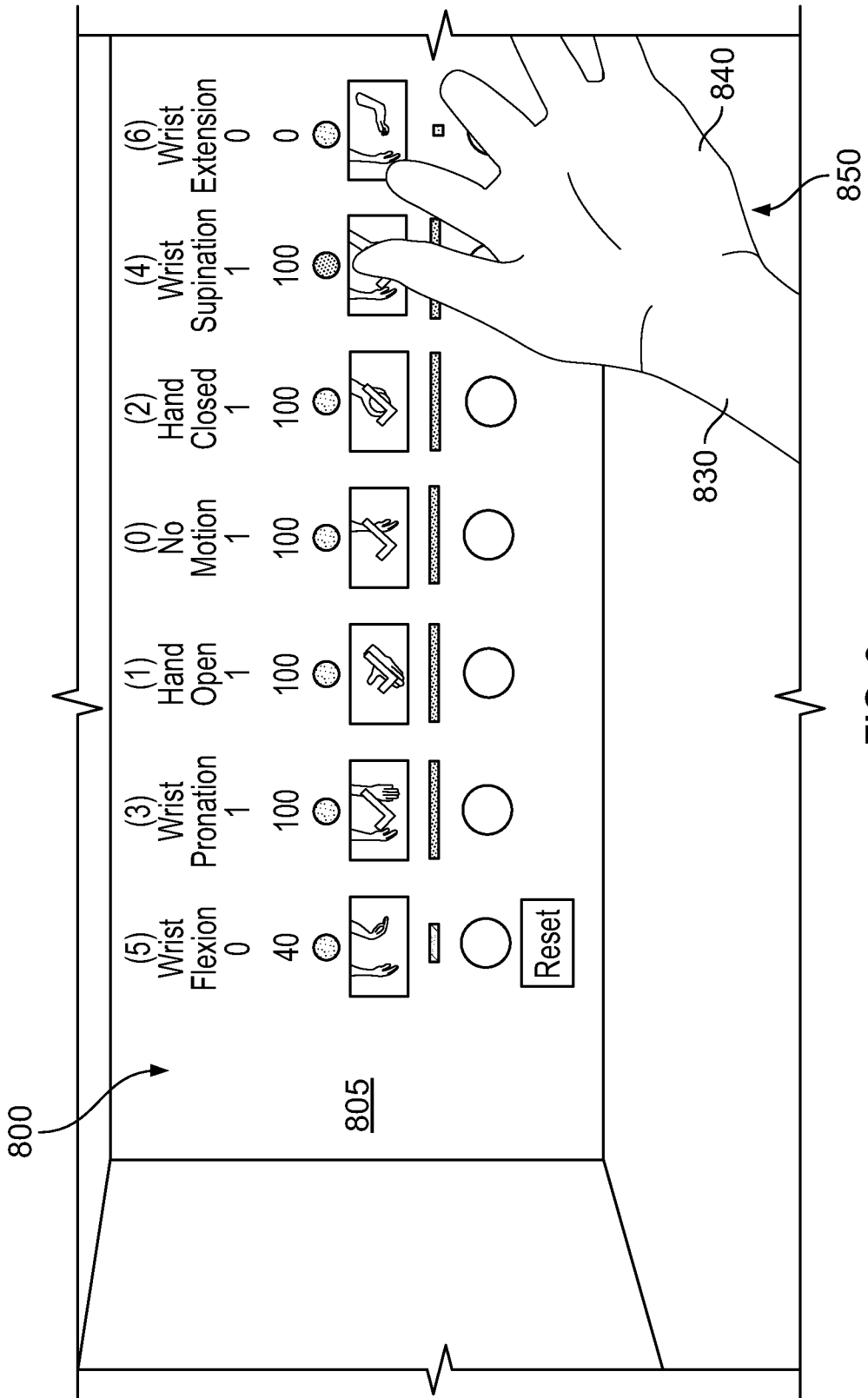
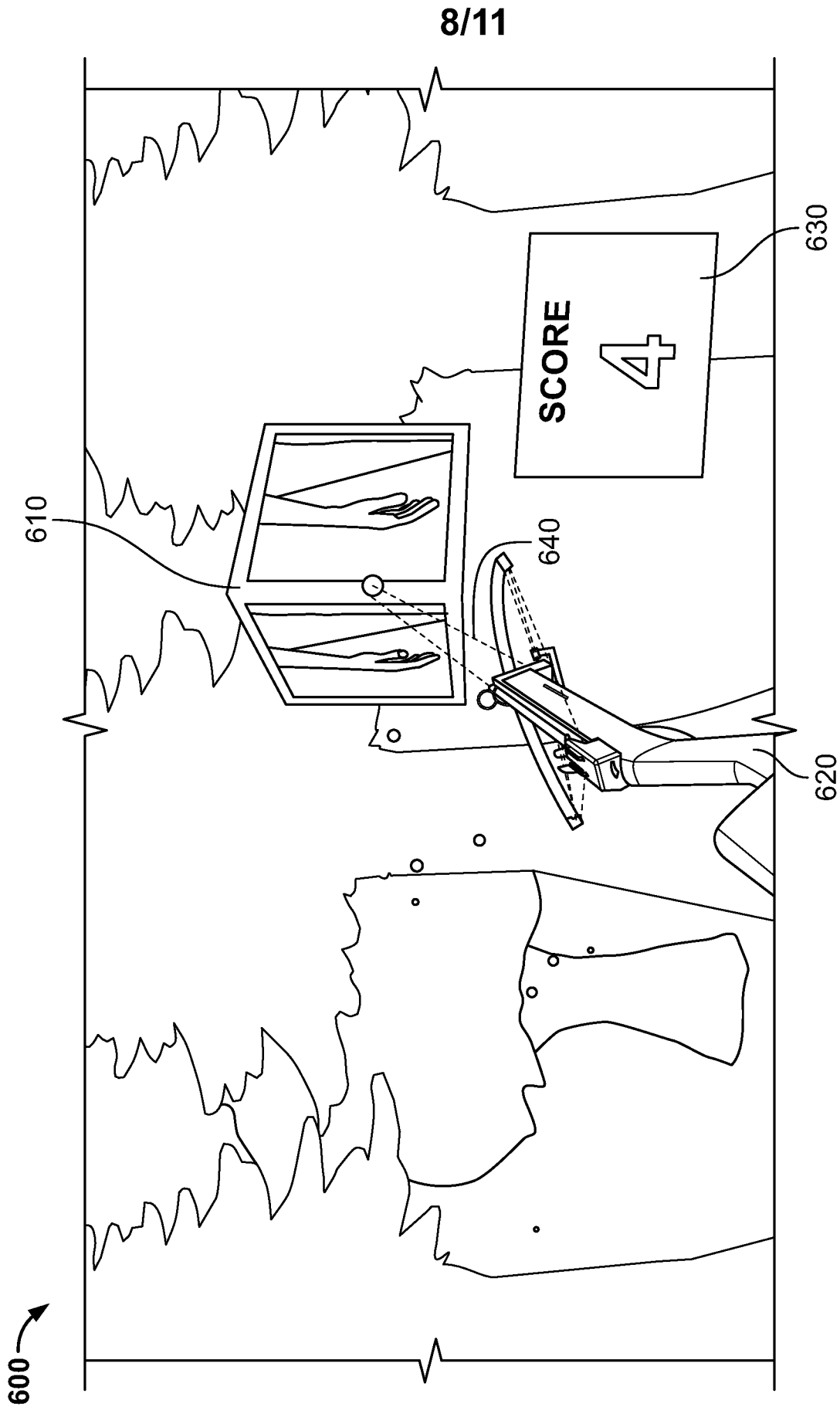

FIG. 9



9/11

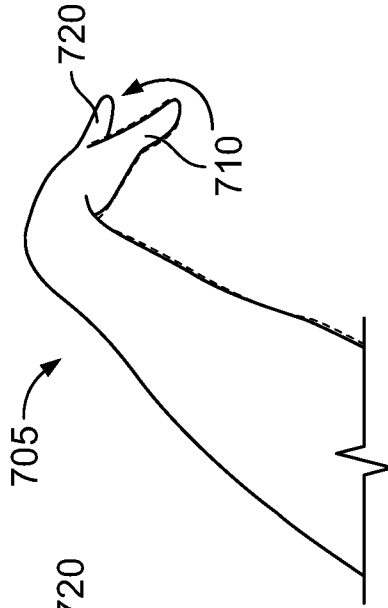

FIG. 11A

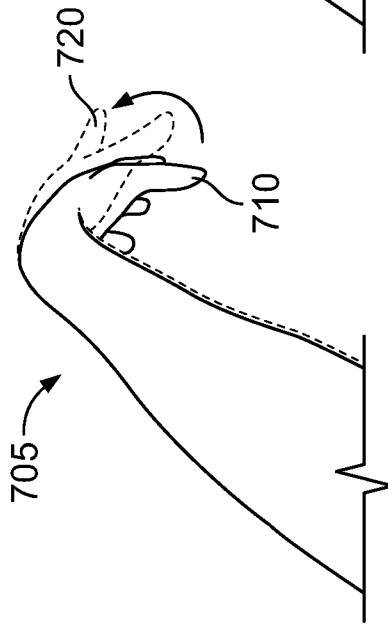

FIG. 11B

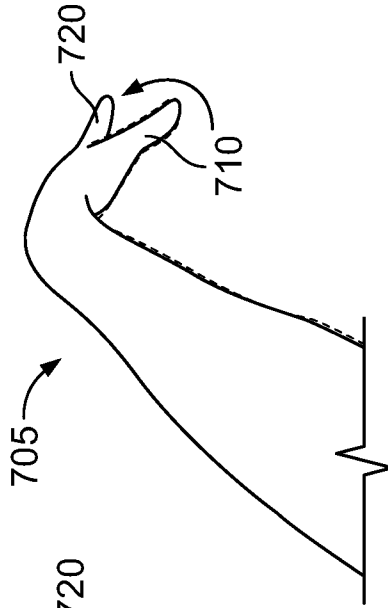

FIG. 11C

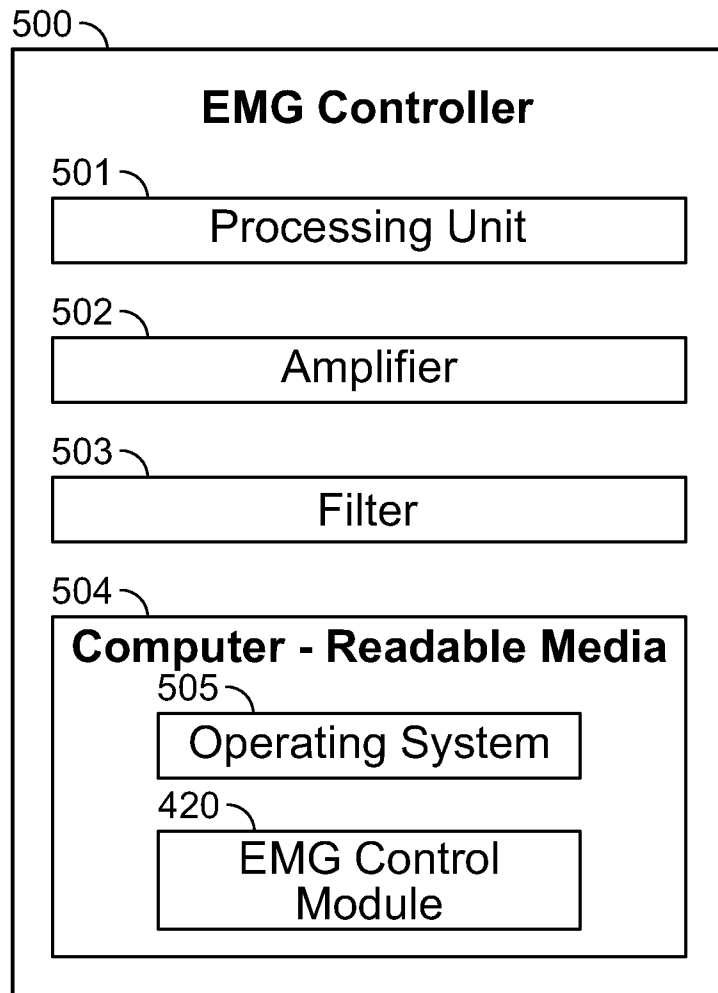

FIG. 12

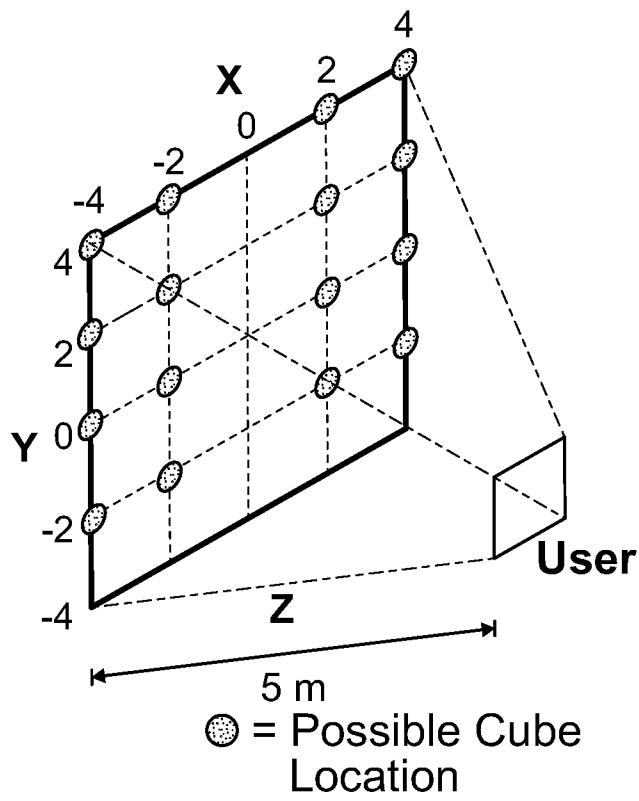

FIG. 13

INTERNATIONAL SEARCH REPORT

International application No.

PCT/US18/27825

A. CLASSIFICATION OF SUBJECT MATTER
 IPC - A61B 5/0488, 5/11; A63F 13/28 (2018.01)
 CPC - A61B 5/0488, 5/1114, 5/7264

According to International Patent Classification (IPC) or to both national classification and IPC

B. FIELDS SEARCHED

Minimum documentation searched (classification system followed by classification symbols)

See Search History document

Documentation searched other than minimum documentation to the extent that such documents are included in the fields searched

See Search History document

Electronic data base consulted during the international search (name of data base and, where practicable, search terms used)

See Search History document

C. DOCUMENTS CONSIDERED TO BE RELEVANT

Category*	Citation of document, with indication, where appropriate, of the relevant passages	Relevant to claim No.
Y --- A	US 2009/0327171 A1 (TAN, D et al.) 31 December 2009; figure 2; paragraphs [0006], [0026], [0028], [0039]	1-4, 8-12, 14, 16 --- 5-7, 13, 15
Y --- A	US 2007/0016265 A1 (DAVOODI, R et al.) 18 January 2007; figure 3; paragraphs [0015], [0016]	1-4, 8-12, 14, 16 --- 5-7, 13, 15
A	US 2014/0198035 A1 (THALMIC LABS INC.) 17 July 2014; entire document	1-16

Further documents are listed in the continuation of Box C.

See patent family annex.

* Special categories of cited documents:

"A" document defining the general state of the art which is not considered to be of particular relevance

"E" earlier application or patent but published on or after the international filing date

"L" document which may throw doubts on priority claim(s) or which is cited to establish the publication date of another citation or other special reason (as specified)

"O" document referring to an oral disclosure, use, exhibition or other means

"P" document published prior to the international filing date but later than the priority date claimed

"T" later document published after the international filing date or priority date and not in conflict with the application but cited to understand the principle or theory underlying the invention

"X" document of particular relevance; the claimed invention cannot be considered novel or cannot be considered to involve an inventive step when the document is taken alone

"Y" document of particular relevance; the claimed invention cannot be considered to involve an inventive step when the document is combined with one or more other such documents, such combination being obvious to a person skilled in the art

"&" document member of the same patent family

Date of the actual completion of the international search

19 June 2018 (19.06.2018)

Date of mailing of the international search report

05 JUL 2018

Name and mailing address of the ISA/

Mail Stop PCT, Attn: ISA/US, Commissioner for Patents
 P.O. Box 1450, Alexandria, Virginia 22313-1450
 Facsimile No. 571-273-8300

Authorized officer

Shane Thomas

PCT Helpdesk: 571-272-4300
 PCT OSP: 571-272-7774