



US 20130065490A1

(19) **United States**

(12) **Patent Application Publication**
Landin et al.

(10) **Pub. No.: US 2013/0065490 A1**

(43) **Pub. Date: Mar. 14, 2013**

(54) **METHOD OF REFURBISHING VINYL COMPOSITION TILE**

(52) **U.S. Cl.**
USPC 451/28

(75) Inventors: **Donald T. Landin**, Eagan, MN (US);
James L. McArdie, Wilson, WI (US)

(57) **ABSTRACT**

(73) Assignee: **3M INNOVATIVE PROPERTIES COMPANY**

(21) Appl. No.: **13/230,287**

(22) Filed: **Sep. 12, 2011**

Publication Classification

(51) **Int. Cl.**
B24B 1/00 (2006.01)

A method of refurbishing vinyl composition tile flooring includes sequentially wet abrading an exposed surface of a vinyl composition tile floor with a series of structured abrasive members affixed to a machine driver pad, wherein the series of structured abrasive members have decreasing abrasive particle size. The method may include a prior abrading step using an aggressive nonwoven abrasive article. The method may include application of polymeric finish after abrading.

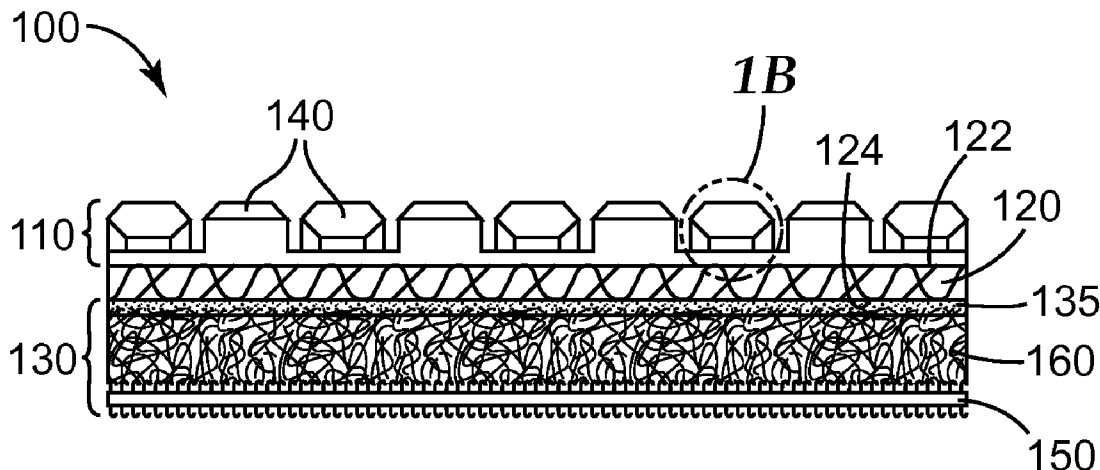

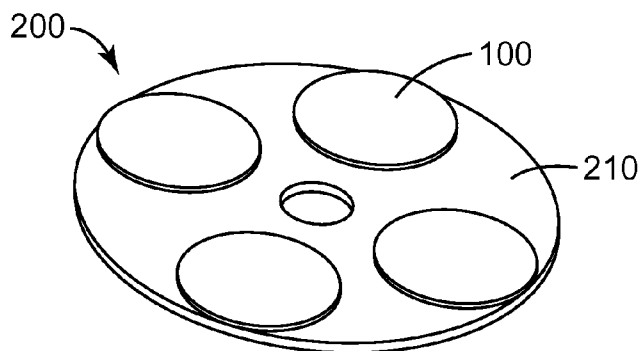
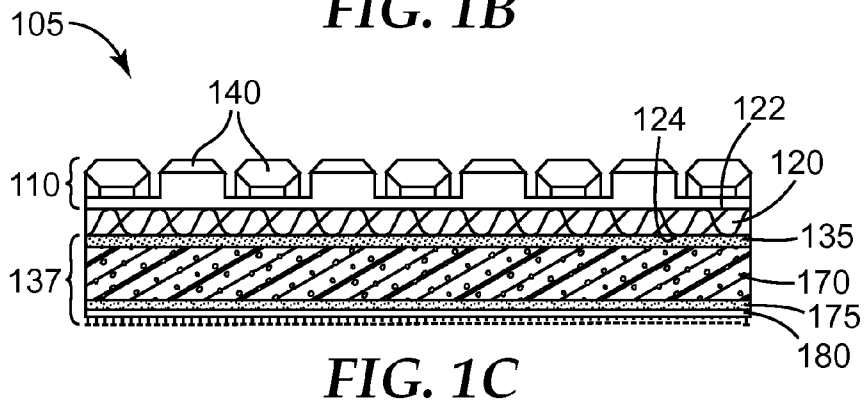
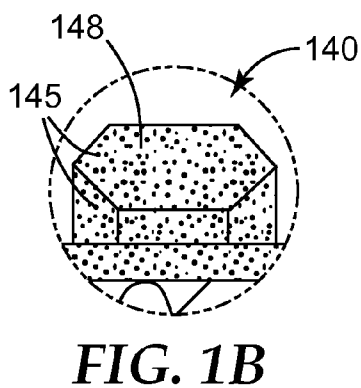
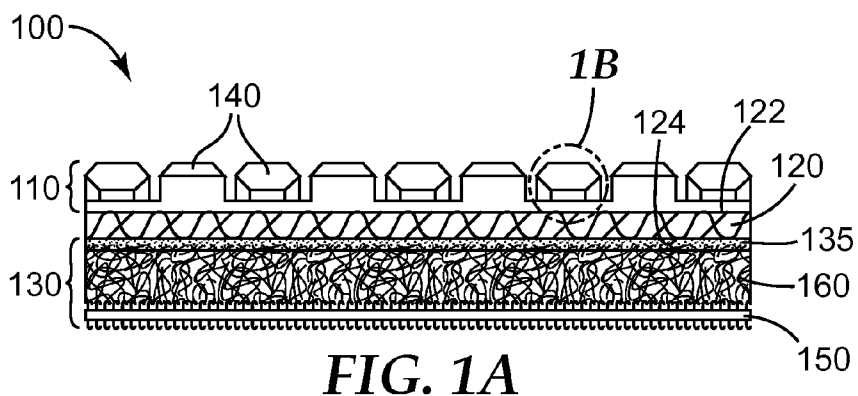

METHOD OF REFURBISHING VINYL COMPOSITION TILE

FIELD

[0001] The present disclosure broadly relates to methods for vinyl composition tile maintenance and repair.

BACKGROUND

[0002] Vinyl composition tile is widely used as flooring in commercial and institutional settings such as, for example, grocery and other retail stores, schools, hospitals, light industrial applications (e.g., laboratories), and restaurants.

[0003] There are two types of vinyl tile. The first, vinyl asbestos tile is comparable to asphalt tile, except that vinyl type resins are the binder instead of asphalt or other resins. As with asphalt tile flooring, asbestos, pigments and inert fillers are used.

[0004] Since about 1982, there have been no vinyl asbestos tiles manufactured. The asbestos was removed and replaced with other fillers. This type of floor tile is generally referred to as Vinyl Composition tile (VC tile). It is more porous than vinyl asbestos tile, and therefore more difficult to build initial gloss. Because of the relatively high filler content, these floors are only available in tile form. The recommended maintenance of VC tile floors generally involves aqueous polymer emulsion coatings and aqueous cleaners and strippers.

[0005] VC tile is generally composed of binder, fillers and pigments compounded with additives such as, for example, stabilizers and processing aides. The binder consists of polymers and/or copolymers of vinyl chloride, other modifying resins, and plasticizers. Vinyl resins are tough, chemically inert, thermoplastic, and resistant to many solvents. Vinyl composition tiles are formed into solid sheets of varying thicknesses (1/8-inch (0.32-cm) is most common) by applying heat and pressure to colored vinyl chips, and are typically cut into squares (e.g., 12-inch (30-cm) squares). VC tile may be supplied with a surface finish layer, but is otherwise generally substantially uniform in appearance throughout its thickness.

[0006] Maintenance of installed VC tile flooring typically involves coating with several coats of a clear polymeric floor finish to achieve satisfactory gloss, followed by frequent (e.g., daily) dusting and burnishing, less frequent scrubbing, and occasional stripping and recoating with floor finish to maintain its appearance.

SUMMARY

[0007] Despite regular maintenance, over the course of time VC tile flooring (e.g., VC tile having one or more layers of floor finish thereon) generally loses its appearance due to physical damage such as gouging and chemical damage that may occur due to floor stripping compositions. Further, stains due to spills (e.g., of iodine antiseptic) may also contribute to deterioration of the appearance of VC tile. In such cases, replacement of the floor tile is the typical remedy; however, this process is time consuming and expensive.

[0008] Advantageously, methods according to the present disclosure can postpone the need for replacement of VC tile (e.g., for years), thereby saving time, cost, and reducing environmental waste.

[0009] Further, in some embodiments, methods according to the present disclosure can be used instead of strip and recoat operations, whereby they can significantly reduce the mess and time required to refurbish the floor appearance.

[0010] In one aspect, the present disclosure provides a method of refurbishing vinyl composition tile flooring, the method comprising sequential steps:

[0011] a) wet abrading at least a portion of an exposed surface of a floor comprising vinyl composition tiles with first structured abrasive members affixed to a first machine driver pad, the first structured abrasive members comprising first shaped abrasive composites affixed to a first compliant backing, wherein the first shaped abrasive composites comprise first abrasive particles dispersed in a first polymeric binder, wherein the first abrasive particles have a first average particle size; and

[0012] b) wet abrading said at least a portion of the exposed surface of the floor with second structured abrasive members affixed to a second machine driver pad, the second structured abrasive members comprising second shaped abrasive composites affixed to a second compliant backing, wherein the second shaped abrasive composites comprise second abrasive particles dispersed in a second polymeric binder, wherein the second abrasive particles have a second average particle size, and wherein the second average particle size is less than the first average particle size; and

[0013] wherein average surface roughness R_a of said at least a portion of the exposed surface of the floor decreases during each of steps a) and b).

[0014] In some embodiments, the method further comprises, after step b):

[0015] c) wet abrading said at least a portion of the exposed surface of the floor with third structured abrasive members affixed to a third compressible resilient machine driver pad, the third structured abrasive members comprising third shaped abrasive composites affixed to a third compliant backing, wherein the third shaped abrasive composites comprise third abrasive particles dispersed in a third polymeric binder, wherein the third abrasive particles have a third average particle size, and wherein the third average particle size is less than the second average particle size; and

[0016] wherein the average surface roughness R_a of said at least a portion of exposed surface of the floor decreases during step c).

[0017] In some embodiments, the method further comprises, subsequent to step b) or step c) (if included), applying a clear polymeric finish to said at least a portion of the exposed surface of the floor.

[0018] In another aspect, the present disclosure provides a method of refurbishing vinyl flooring, the method comprising sequential steps:

[0019] a) wet abrading at least a portion of an exposed surface of floor comprising vinyl composition tiles with a nonwoven abrasive member, wherein the nonwoven abrasive member comprises a nonwoven fiber web having first abrasive particles adhered thereto by a first polymeric binder, wherein the first abrasive particles have a first average particle size;

[0020] b) wet abrading said at least a portion of the exposed surface of the floor with first structured abrasive members affixed to a first machine driver pad, the first structured abrasive members comprising first shaped abrasive composites affixed to a first compliant backing, wherein the first shaped abrasive composites comprise second abrasive particles dispersed in a second polymeric binder, wherein the second abrasive particles have a second average particle size that is smaller than the first average particle size; and

[0021] c) wet abrading said at least a portion of the exposed surface of the floor with second structured abrasive members affixed to a second machine driver pad, the second structured abrasive members comprising second shaped abrasive composites affixed to a second compliant backing, wherein the second shaped abrasive composites comprise third abrasive particles dispersed in a third polymeric binder, wherein the third abrasive particles have a third average particle size, and wherein the third average particle size is less than the second average particle size; and

[0022] wherein average surface roughness R_a of the abraded exposed surface of the floor decreases during each of steps b) and c).

[0023] In some embodiments, the method further comprises, after step c):

[0024] d) wet abrading said at least a portion of the exposed surface of the floor with third structured abrasive members affixed to a third compressible resilient machine driver pad, the third structured abrasive members comprising third shaped abrasive composites affixed to a third compliant backing, wherein the third shaped abrasive composites comprise fourth abrasive particles dispersed in a fourth polymeric binder, wherein the fourth abrasive particles have a fourth average particle size; and wherein the fourth average particle size is less than the third average particle size; and

[0025] wherein the average surface roughness R_a of said at least a portion of the exposed surface of the floor decreases during step d).

[0026] In some embodiments, the method further comprises, subsequent to step c) or step d) (if included), applying a clear polymeric finish to the abraded exposed surface of the floor.

[0027] Conventional nonwoven diamond abrasive floor pads conform to height irregularities in the floor and are not very effective for planarizing the floor surface. In contrast; the structured abrasive members used in methods according to the present disclosure have sufficient stiffness that they are capable of effectively abrading off high spots on the floor and generating like new, or even better than new, appearance.

[0028] As used herein,

[0029] the term “compliant” means yielding and/or conforming in response to applied pressure;

[0030] the term “(meth)acryl” refers to acryl and/or methacryl;

[0031] the terms “polymer” and “polymeric” refer to an organic polymer;

[0032] the term “subsequent” means at a later time, which may be immediate or at a later time (e.g., after one or more intervening abrading steps or other processes or events); and

[0033] the term “wet abrading” refers to abrading in the presence of water, the water optionally containing one or more additional components such as, for example, organic solvents, pH modifiers, colorants, dyes, fragrances, disinfectants, and surfactants.

[0034] As used herein, surface roughness R_a and R_z are as defined in the Examples section hereinbelow.

[0035] The features and advantages of the present disclosure will be further understood upon consideration of the detailed description as well as the appended claims.

BRIEF DESCRIPTION OF THE DRAWING

[0036] FIG. 1A is a schematic side view of an exemplary structured abrasive member 100 useful in practice of the present disclosure.

[0037] FIG. 1B is an enlarged view of region 1B in FIG. 1A.

[0038] FIG. 1C is a schematic side view of an exemplary structured abrasive member 105 useful in practice of the present disclosure.

[0039] FIG. 2 is a schematic perspective bottom view of an exemplary arrangement of structured abrasive members affixed to a compressible resilient machine driver pad useful in practice of methods according to the present disclosure.

[0040] While the above-identified drawing figures set forth several embodiments of the present disclosure, other embodiments are also contemplated, for example, as noted in the discussion. In all cases, the disclosure is presented by way of representation and not limitation. It should be understood that numerous other modifications and embodiments can be devised by those skilled in the art, which fall within the scope and spirit of the principles of the disclosure. The figures may not be drawn to scale. Like reference numbers may have been used throughout the figures to denote like parts.

DETAILED DESCRIPTION

[0041] Methods according to the present disclosure are suitable for refurbishing vinyl composition tile flooring. Preferably, prior to practicing methods according to the present disclosure, the flooring to be refurbished should be inspected and cracked, raised and/or blistered, or broken tiles replaced. In some embodiments, preexisting floor finish may be removed using conventional wet stripping techniques. In some embodiments, preexisting floor finish is removed using an aggressive nonwoven abrasive member; for example, a floor finish stripping pad used in conventional wet stripping processes. Preferably, the area of the floor involved is cordoned off from public access during the refurbishing process.

[0042] In one embodiment, a method of refurbishing vinyl flooring according to the present disclosure comprises wet abrading an exposed surface of a floor comprising vinyl composition tiles with first structured abrasive members affixed to a first compressible resilient machine driver pad, and then wet abrading the exposed surface of the floor with second structured abrasive members affixed to a second compressible resilient machine driver pad. In some embodiments, the method then further comprises wet abrading the exposed surface of the floor with third structured abrasive members affixed to a third compressible resilient machine driver pad.

[0043] After wet abrading with one of the structured abrasive members, the abraded portion of a typical VC tile floor is smoother (has less roughness) than before the abrading step. Of course, the degree of roughness will depend on the initial roughness before abrading, the duration and applied force while abrading, the nature of the abrasive member, and the abrasive particle size. For example, in some embodiments, after wet abrading with structured abrasive members (e.g., steps a), b), and c); or steps b), c), and d); depending on the embodiment) the average surface roughness R_a may be less than or equal to 120 microinches (3.05 microns) (e.g., after wet abrading with a 300- μ m diamond structured abrasive disc), 95 microinches (2.41 microns) (e.g., after wet abrading with a 45- μ m diamond structured abrasive disc), 80 microinches (2.03 microns) (e.g., after wet abrading with a 0- μ m diamond structured abrasive disc) down to 70 microinches (1.78 microns), 60 microinches (1.52 microns), 50 microinches (1.27 microns), 40 microinches (1.02 microns), 30 microinches (0.76 microns) (e.g., after wet abrading with a 6- μ m diamond structured abrasive disc), or 20 microinches

(0.51 microns), or even less than 10 microinches (0.25 microns) (e.g., after wet abrading with a 3- μ m diamond structured abrasive disc).

[0044] Similarly, the surface roughness R_z of the abraded portion of the VC the floor, after wet abrading with structured abrasive members (e.g., steps a), b), and c); or steps b), c), and d); depending on the embodiment) may be less than or equal to 700 microinches (17.8 microns) (e.g., after wet abrading with a 300- μ m diamond structured abrasive disc), 600 microinches (15.2 microns) (e.g., after wet abrading with a 45- μ m diamond structured abrasive disc), 525 microinches (13.3 microns) (e.g., after wet abrading with a 10- μ m diamond structured abrasive disc) down to 500 microinches (12.7 microns), 430 microinches (10.9 microns), 360 microinches (9.14 microns), 280 microinches (7.11 microns), 180 microinches (4.57 microns) (e.g., after wet abrading with a 6- μ m diamond structured abrasive disc), or 150 microinches (3.81 microns), or even less than 100 microinches (2.54 microns) (e.g., after wet abrading with a 3- μ m diamond structured abrasive disc).

[0045] Referring now to FIG. 1A, exemplary structured abrasive member 100 comprises structured abrasive layer 110 disposed on first surface 122 of compliant backing 120. Optional attachment interface system 130 is secured to second surface 124 of compliant backing 120 by adhesive layer 135. Optional attachment interface system 130 further includes looped portion 160 of a hook and loop fastener, and hooked interface pad 150 having hooked portions of a hook and loop fastening system on opposing sides thereof.

[0046] Structured abrasive layer 110 comprises a plurality of shaped abrasive composites 140, which are composites of abrasive particles 145 distributed in a binder 148 (e.g., see FIG. 1B). Generally, the shaped abrasive composites are rigid. Shaped abrasive composites 140 are separated by a boundary or boundaries associated with the shape of the shaped abrasive composite, resulting in one shaped abrasive composite being separated to some degree from adjacent abrasive composites. One of the earliest references to abrasive articles with shaped abrasive composites (e.g., precisely-shaped abrasive composites) is U.S. Pat. No. 5,162,917 (Pieper et al.). Many others have followed. The term "precisely-shaped abrasive composite", as used herein, refers to abrasive composites having a shape that has been formed by curing a curable flowable mixture of abrasive particles and curable binder precursor while the mixture is both being borne on a backing and filling a cavity on the surface of a production tool. Such a precisely-shaped abrasive composites have precisely the same shape as that of the cavity. A plurality of such composites provide three-dimensional shapes that project outward from the surface of the backing in a non-random pattern, namely the inverse of the pattern of the production tool. Each composite is defined by a boundary, the base portion of the boundary being the interface with the backing to which the precisely shaped composite is adhered. The remaining portion of the boundary is defined by the cavity on the surface of the production tool in which the composite was cured. The entire outer surface of the composite is confined, either by the backing or by the cavity, during its formation.

[0047] Useful compliant backings 120 may include those known useful in abrasive articles such as, for example, metal, thick polymeric sheets and/or films (e.g., polycarbonate), saturant-treated cloths (e.g., glass and/or polyester cloth) and nonwoven fabrics, treated or primed versions thereof, and

combinations thereof. Examples include polyester sheets, polyolefin sheets (e.g., polyethylene and propylene sheet), polyamide sheets, polyimide sheets, and polycarbonate sheets.

[0048] Abrasive particles 145 may comprise, for example, fused aluminum oxide (including white fused alumina, heat-treated aluminum oxide, and brown aluminum oxide), ceramic aluminum oxide (including shaped ceramic alumina particles), heated treated aluminum oxide, silicon carbide, diamond (natural and synthetic), cubic boron nitride, boron carbide, titanium carbide, cubic boron nitride, garnet, fused alumina-zirconia, diamond, zirconia, and combinations thereof. Of these, diamonds are preferred. Useful diamonds may be either natural diamonds or man-made diamonds. The diamonds may include a surface coating (e.g., nickel or other metal) to improve the retention of the diamonds in the resin matrix.

[0049] Abrasive particles 145 may also be present in abrasive aggregates. Such aggregates comprise a plurality of the abrasive particles, a matrix material, and optional additives. The matrix material may be organic and/or inorganic. The matrix material can be, for example, polymer resin, glass (e.g., vitreous-bond diamond aggregates), metal, glass-ceramic, ceramic (e.g., ceramic-bond agglomerates as described in U.S. Pat. No. 6,790,126 (Wood et al.)), or a combination thereof. For example, glass, such as silica glass, glass-ceramics, borosilicate glass, phenolic, epoxy, acrylic, and the other resins described in the context of the composite binder can be used as the matrix material. Abrasive aggregates may be randomly shaped or have a predetermined shape associated with them. Additional details regarding various abrasive aggregates and methods of making them may be found, for example, in U.S. Pat. No. 4,311,489 (Kressner); U.S. Pat. No. 4,652,275 (Bloecher et al.); U.S. Pat. No. 4,799,939 (Bloecher et al.); U.S. Pat. No. 5,549,962 (Holmes et al.); U.S. Pat. No. 5,975,988 (Christianson); U.S. Pat. No. 6,620,214 (McArdle), U.S. Pat. No. 6,521,004 (Culler et al.); U.S. Pat. No. 6,551,366 (D'Souza et al.); U.S. Pat. No. 6,645,624 (Adefitis et al.); and U.S. Pat. No. 7,169,031 (Fletcher et al.); and in U.S. Publ. Patent Appl. 2007/0026770 (Fletcher et al.).

[0050] Vitreous-bond abrasive aggregates can be made, for example, by providing a plurality of glass bodies made from the glass binder, each glass body having a defined shape, and glass bodies having a softening temperature, providing a plurality of abrasive particles, mixing the plurality of glass bodies and the plurality of abrasive particles together to form a mixture, heating the mixture to the softening temperature of glass bodies so that glass bodies soften while substantially retaining the defined shape, adhering abrasive particles to the softened glass bodies to form a plurality of abrasive aggregates, and cooling abrasive aggregates so that the glass binder of glass bodies hardens. Further details are described in U.S. Pat. No. 7,887,608 (Schwabel et al.).

[0051] The abrasive particles may further comprise a surface treatment or coating such as, for example, a coupling agent or metal or ceramic coating. Preferably, the abrasive particles have a Mohs hardness of at least 7, preferably at least 8, and more preferably at least 9.

[0052] The abrasive particles preferably have an average particle size in a range of from about 0.01 micrometer (small particles) to 500 micrometers (large particles), more preferably about 0.25 micrometers to about 500 micrometers, even more preferably about 3 micrometers to about 400 micrometers, and most preferably about 5 micrometers to about 50

micrometers. Occasionally, abrasive particle sizes are reported as “mesh” or “grade”, both of which are commonly known abrasive particle sizing methods.

[0053] The choice of abrasive particle size will typically depend on the point in the refurbishing process of the present disclosure at which it is to be used, with the average size of the abrasive particles decreasing with each successive structured abrasive member (e.g., first, then second, and optionally then third).

[0054] Shaped abrasive composites **140** may optionally include diluent particles, which are not sufficiently hard to serve effectively as abrasive particles. The particle size of these diluent particles may be on the same order of magnitude as the abrasive particles. Examples of such diluent particles include gypsum, marble, limestone, flint, silica, glass bubbles, glass beads, and aluminum silicate.

[0055] Abrasive particles **145** are adhered one to another with binder **148** to form shaped abrasive composites **140** (e.g., see FIG. 1B). Binder **148** is an organic and/or polymeric binder, and is derived from a binder precursor. In preferred embodiments, abrasive particles **145** are present in vitreous-bond abrasive aggregates (not shown).

[0056] During the manufacture of structured abrasive layer **110**, the binder precursor is exposed to an energy source which aids in the initiation of polymerization or curing of the binder precursor.

[0057] Examples of energy sources include thermal energy and radiation energy, the latter including electron beam, ultraviolet light, and visible light. During this polymerization process, the binder precursor is polymerized or cured and is converted into a solidified binder. Upon solidification of the binder precursor, the adhesive matrix is formed.

[0058] Binder **148** can be formed, for example, of a curable (via energy such as UV light or heat) organic binder precursor material. Examples include alkylated urea-formaldehyde resins, melamine-formaldehyde resins, and alkylated benzoguanamine-formaldehyde resin, acrylate resins (including acrylates and methacrylates) such as vinyl acrylates, acrylated epoxies, acrylated urethanes, acrylated polyesters, acrylated acrylics, acrylated polyethers, vinyl ethers, acrylated oils, and acrylated silicones, alkyl resins such as urethane alkyl resins, polyester resins, reactive urethane resins, phenolic resins such as resole and novolac resins, phenolic latex resins, epoxy resins such as bisphenol epoxy resins, isocyanates, isocyanurates, polysiloxane resins (including alkylalkoxysilane resins), reactive vinyl resins, phenolic resins (resole and novolac), and the like. The resins may be provided as monomers, oligomers, polymers, or combinations thereof. To facilitate curing, the binder precursor may include one or more of photoinitiators, crosslinkers, thermal initiators, catalysts, and combinations thereof. Such materials are well known in the art.

[0059] Another useful method of making structured abrasive members having shaped abrasive composites where the composites comprise abrasive aggregates fixed in a make coat, with optional size coatings, is described in U.S. Pat. No. 6,217,413 (Christianson). Embossing and/or screen printing may also be used to form shaped abrasive composites as described in, for example, U.S. Pat. No. 5,014,468 (Ravipati et al.).

[0060] The structured abrasive members may have any shape such as, for example, discs, squares, daisies, rectangular strips, rings, crescents, spirals, wavy lines, or any 2-dimensional geometric shape.

[0061] Examples of commercially available structured abrasive members suitable for use in the present disclosure include, for example, those available as 3M TRIZACT DIAMOND HX Gold, Red, and Blue discs from 3M Company, St. Paul, Minn.

[0062] Further details concerning methods and materials for making structured abrasive members can be found, for example, in U.S. Pat. No. 5,152,917 (Pieper et al.) and U.S. Pat. No. 5,435,816 (Spurgeon et al.), U.S. Pat. No. 5,437,754 (Calhoun), U.S. Pat. No. 5,454,844 (Hibbard et al.), U.S. Pat. No. 5,304,223 (Pieper et al.), and U.S. Pat. No. 7,300,479 (McArdle et al.).

[0063] Optional attachment interface system **130** may comprise, for example, the hooked portion of a hook and loop fastening system, or capped stems of a self-mating mechanical fastener (e.g., as described in U.S. Pat. No. 5,672,186 (Chesley et al.) or U.S. Pat. No. 5,201,101 (Rouser et al.)). Optional attachment interface system may comprise multiple elements such as, for example, a looped portion of a hook and loop fastener in combination with an interface pad having hooked portions of a hook and loop fastener on opposite sides thereof, thereby providing a hooked outer surface for mounting to the machine driver pad.

[0064] In another embodiment, shown in FIG. 1C, exemplary structured abrasive member **105** comprises structured abrasive layer **110** disposed on first surface **122** of compliant backing **120**. Attachment interface system **137** is secured to second surface **124** of compliant backing **120** by adhesive layer **135**. As shown, attachment interface system **137** comprises one half of a capped-stem self-mating fastener comprising foam layer **170**, auxiliary adhesive layer **175**, and capped stem backing **180**. However, other attachment interface systems having hook-type projections may also be used (e.g., i-hook fasteners and T-hook fasteners).

[0065] Suitable optional interface layers are typically compressible and conformable. Preferably the optional attachment layer has sufficient overall thickness that it raises the structured abrasive members beyond the surface of machine driver pad to which it is attached, so that the machine driver pad does not substantially reduce the contact pressure between the structured abrasive members and the floor surface. Accordingly, in some embodiments, the optional interface layer may have a thickness in a range of from 2 millimeters to 13 millimeters, preferably from 2 millimeters to 5 millimeters.

[0066] if the optional attachment interface system is not present, then sonic other method for mounting the pads (e.g., such as adhesive) may be used. In such cases, and indeed in most instances, it may be desirable multiple to securely mount structured abrasive members to the compressible resilient nonwoven machine driver pad to form an assembly for each type of structured abrasive member used. Accordingly, to change from one structured abrasive member type to another it is only necessary to change structured abrasive member/compressible resilient machine driver pad assemblies, instead of remounting individual structured abrasive members.

[0067] The first, second, and optional third structured abrasive members independently comprise shaped abrasive composites affixed to a compliant backing (i.e., the backing is prone to irreversible mechanical damage if subjected to more than incidental flexing). Each of the shaped abrasive composites comprises abrasive particles dispersed in a first polymeric binder. The average particle size of abrasive particles in each

successive structured abrasive member is smaller than the previous one, thereby resulting in ever increasing levels of surface roughness, while achieving reasonable overall abrading rates.

[0068] While the shaped abrasive composites of the structured abrasive members contained ever decreasing particle sizes, the other components such as for example, binder abrasive particle composition, compliant backing, and size, shape, and/or arrangement of the abrasive composites may change. In some circumstances, this may lead to increase in surface roughness of the VC tile floor, and such combination of structured abrasive members should generally be avoided, or followed by additional abrading steps to smooth the floor surface. To avoid this problem, it is desirable that the structured abrasive members be substantially the same (e.g., in terms of the shape, size, composition, and arrangement of the shaped abrasive composites, composition of abrasive particles, and for the compliant backing), except for the average size of the abrasive particles.

[0069] The machine driver pads may be made of any material capable of supporting the structured abrasive members (e.g., metal plates, nonwoven pads, foams, rubber discs). In some embodiments, machine driver pads are capable of compressing and recovering without substantial permanent deformation (i.e., they are compressible and resilient). Compressibility and resiliency allow the machine driver pad to float over gradual irregularities in height of the floor (which may be cause, for example, by an underlying concrete surface), whereas a rigid machine driver pad may be prone to gouging the floor in such circumstances (e.g., depending on the floor maintenance machine design). Preferably, the machine driver pads comprise nonwoven material having a disc-shape (although other shapes may also be used) and having a thickness and compressibility typically of a conventional buffing pad for a swing arm buffing machine. For example, the machine driver pads may comprise a nonwoven fiber disc having a thickness in a range of from 1 to 5 centimeters (cm) and a diameter in a range of from 0.3 to 1 meter. Useful nonwoven materials may comprise, for example, synthetic fibers (e.g., polyester, polyamide, polyolefin, and bicomponent core-shell synthetic fibers), natural fibers (e.g., banana, flax, cotton, jute, agave, sisal, coconut, soybean, and hemp), and combinations of the foregoing. The machine driver pad may have abrasive particles bonded to nonwoven fibers.

[0070] Lofty nonwoven machine driver pads may be prepared according to conventional methods such as, for example, by forming a low density air-laid fiber web using a Rando Webber web-forming machine commercially available from Rando Machine Corporation, Macedon, N.Y. In some embodiments a blend of fibers may be used. One exemplary such blend includes polyester (polyethylene terephthalate) staple fibers and crimped sheath-core melt-bondable polyester staple fibers. The fiber web is then optionally heated in a hot convection oven to activate any melt-bondable fibers in the fiber web and pre-bond the web.

[0071] Examples of suitable melt-bondable fibers are described in U.S. Pat. No. 5,082,720 (Hayes). The fibers are preferably tensilized and crimped, but may also be continuous filaments such as those formed by an extrusion process, e.g., as described in U.S. Pat. No. 4,227,350 (Fitzer).

[0072] The optionally pre-bonded fiber web is then coated with a liquid binder precursor composition by passing it between the coating rolls of a two roll coater, wherein the bottom coating roll is partially immersed in the liquid binder

resin composition. Exemplary liquid binder precursor compositions include aminoplasts, urea-formaldehyde resins, phenolics, epoxies, and urethanes, although other binder precursors may also be used. The coated nonwoven web is then placed in an oven heated to cure the liquid binder precursor resin, and produce a bonded nonwoven web.

[0073] In some embodiments, the machine driver pad comprises an open nonwoven fiber substrate (e.g., a nonwoven fiber disc) that has no external backing layer. Suitable nonwoven compressible resilient backings are also available from commercial sources such as, for example, 3M WHITE SUPER POLISH PAD 4100, 3M RED BUFFER PAD 5100, and 3M NATURAL BLEND WHITE PAD 3300 floor pads all from 3M Company, St. Paul., Minn. In some embodiments, the compressible resilient backing may comprise a foam (e.g., a foam disc). Laminate constructions such as, for example, foam and nonwoven fiber web laminate may also be used.

[0074] VC tile is generally substantially uniform in appearance throughout its thickness. VC tile is widely available from commercial suppliers such as, for example, Armstrong World Industries, Inc., Lancaster, Pa.; Mannington Mills, Salem, N.J.; and Congoleum Corp., Mercerville, N.J.

[0075] The structured abrasive members are secured to the compressible resilient backing the first structured abrasive members, the second structured abrasive members, or optionally the third structured abrasive members), which in turn is typically mounted to a low speed (i.e., from about 175 to about 350 revolutions per minute) mechanical device of the type used to maintain VC tile flooring. Examples include manually operated rotary floor machines and walk-behind or riding autoscrubbers. FIG. 2 shows an exemplary assembly **200** of structured abrasive members **100** affixed to a machine driver pad **210** that is useful in practice of the present disclosure. Any appropriate number of structured abrasive members may be used (e.g., the number of structured abrasive members may be 1, 2, 3, 4, 5, 6, 7, 8, 9, 10, or more), in any arrangement. Typically, the structured abrasive members are symmetrically arranged on the surface of the compressible resilient machine driver pad, although other arrangements may also be used. Also, the structured abrasive members are typically positioned so that they are adjacent the peripheral edge of the compressible resilient machine driver pad, although other arrangements may also be used.

[0076] In some embodiments, a non-woven pad having diamonds bonded thereto may be useful for final burnishing of the VC tile flooring after the wet abrading steps (e.g., a), b), and optionally c)) with structured abrasive members. Examples include those available as 3M SCOTCH-BRITE PURPLE DIAMOND FLOOR PAD PLUS and 3M SCOTCH-BRITE SIENNA DIAMOND FLOOR PAD PLUS from 3M Company. Such pads may also be used in one or more additional slow speed wet abrading steps that can optionally be used to augment processes according to the present disclosure. High-speed burnishing (e.g., at speeds in excess of 1000 revolutions per minute) to improve the aesthetic quality of the surface of the floor is preferably used as a final step in processes according to the present disclosure, however this is not a requirement. High speed burnishing can be carried out using methods well known in the art, for example, using an electric, battery, or propane burnishing machine.

[0077] VC tile flooring may be pre-conditioned so that it is more suited to abrading according to the present disclosure.

For example, existing floor finish may be removed using a chemical stripper and a nonwoven stripping pad. Desirably, chemical stripping is omitted as it is messy, time consuming, and aesthetically unpleasant. Accordingly, in some embodiments, no pre-conditioning step is used, while in others, an aggressive abrasive floor pad is used to remove the finish without aid of stripper (although water may be useful for dust control). Examples of such aggressive abrasive floor pads are available as 3M BLACK STRIPPER PAD 7200, 3M BROWN STRIPPER PAD 7100, 3M HIGH PRODUCTIVITY PAD 7300, and 3M CLEAN AND STRIP XT floor pads, all from 3M Company.

[0078] Whether the floor is pre-conditioned or not, a portion of the exposed surface of VC tile floor is abraded with first structured abrasive members affixed to the first compressible resilient machine driver pad, the first structured abrasive members comprising first shaped abrasive composites affixed to a first compliant backing, wherein the first shaped abrasive composites comprise first abrasive particles dispersed in a first polymeric binder, wherein the first abrasive particles have a first average particle size. In some embodiments, the first average particle size is in a range of from 200 to 400 microns, preferably from 250 to 350 microns.

[0079] After the first wet abrading step is complete, the process is repeated again using the second structured abrasive members with second abrasive particles having a second average particle size that is smaller than the first average particle size. In some embodiments, the second average particle size is in a range of from 25 to 75 microns, preferably from 35 to 65 microns.

[0080] After the wet abrading steps using the first and second structured abrasive members are complete, the floor may be sufficiently restored for use. However, in some instances it may be desirable to carry out additional (for example, a third and optionally a fourth) wet abrading processes as above, but using successively smaller average abrasive particle sizes.

[0081] Once the VC tile floor has been abraded (i.e., resurfaced and/or restored) as described above, a clear polymeric finish may be applied to enhance appearance and protect the floor from wear. The clear polymeric finish may include water-soluble or water-dispersible film formers such as metal-free acrylic finishes, acid-containing polymers crosslinked using transition metals, and water-soluble or water-dispersible multicomponent (e.g., two-component) polyurethanes. The clear polymeric finish may contain mixtures of film formers.

[0082] Examples of suitable commercially available clear polymeric finishes include acrylic floor finishes 3M SCOTCHGARD VINYL FLOOR PROTECTOR, 3M CORNERSTONE, 3M SCOTCHGARD UHS 25 FLOOR FINISH, and 3M SCOTCHGARD LM 25 FLOOR FINISH, and polyurethane finishes such as 3M SCOTCHGARD ULTRA DURABLE FLOOR FINISH from 3M Company, Saint Paul, Minn.

SELECTED EMBODIMENTS OF THE PRESENT DISCLOSURE

[0083] In a first embodiment, the present disclosure provides a method of refurbishing vinyl composition tile flooring, the method comprising sequential steps:

[0084] a) wet abrading at least a portion of an exposed surface of a floor comprising vinyl composition tiles with first structured abrasive members affixed to a first machine driver pad, the first structured abrasive members comprising first

shaped abrasive composites affixed to a first compliant backing, wherein the first shaped abrasive composites comprise first abrasive particles dispersed in a first polymeric binder, wherein the first abrasive particles have a first average particle size; and

[0085] b) wet abrading said at least a portion of the exposed surface of the floor with second structured abrasive members affixed to a second machine driver pad, the second structured abrasive members comprising second shaped abrasive composites affixed to a second compliant backing, wherein the second shaped abrasive composites comprise second abrasive particles dispersed in a second polymeric binder, wherein the second abrasive particles have a second average particle size, and wherein the second average particle size is less than the first average particle size; and

[0086] wherein average surface roughness R_a of said at least a portion of the exposed surface of the floor decreases during each of steps a) and b).

[0087] In a second embodiment, the present disclosure provides a method according to the first embodiment, wherein average surface roughness R_z of said at least a portion of the exposed surface of the floor decreases during each of steps a) and b).

[0088] In a third embodiment, the present disclosure provides a method according to the first or second embodiment, wherein each of the first structured abrasive members further comprise a first attachment interface system secured to the first compliant backing, the first attachment interface system having a plurality of loops opposite the first compliant backing, wherein the first structured abrasive members are affixed to the first machine driver pad by a first attachment interface member having two opposed major faces having hooks extending therefrom.

[0089] In a fourth embodiment, the present disclosure provides a method according to any of the first to third embodiments, wherein each of the first structured abrasive members further comprise a first compliant foam layer secured to the first compliant backing, and an attachment interface system having a plurality of hooks opposite the first compliant foam layer.

[0090] In a fifth embodiment, the present disclosure provides a method according to any of the first to fourth embodiments, wherein each of the second structured abrasive members further comprise a second compliant foam layer secured to the second compliant backing, and an attachment interface system having a plurality of hooks opposite the second compliant foam layer.

[0091] In a sixth embodiment, the present disclosure provides a method according to any of the first to fifth embodiments, wherein each of the second structured abrasive members further comprises a second attachment interface system secured to the second compliant backing, the second attachment interface system having a plurality of loops opposite the second compliant backing, wherein the second structured abrasive members are affixed to the second machine driver pad by an attachment interface member having two opposed major faces having hooks extending therefrom.

[0092] In a seventh embodiment, the present disclosure provides a method according to any of the first to sixth embodiments, wherein the first and second machine driver pads are compressible and resilient.

[0093] In an eighth embodiment, the present disclosure provides a method according to any of the first to seventh

embodiments, wherein the first shaped abrasive composites, the second shaped abrasive composites, or both, are precisely-shaped.

[0094] In a ninth embodiment, the present disclosure provides a method according to any of the first to eighth embodiments, wherein the first average particle size is in a range of from 400 microns to 600 microns.

[0095] In a tenth embodiment, the present disclosure provides a method according to any of the first to ninth embodiments, wherein the second average particle size is in a range of from 25 microns to 75 microns.

[0096] In an eleventh embodiment, the present disclosure provides a method according to any of the first to tenth embodiments, wherein at least one of the first or second shaped abrasive composites comprises superabrasive particles retained in a vitreous binder.

[0097] In a twelfth embodiment, the present disclosure provides a method according to any of the first to eleventh embodiments, wherein after step b) the average surface roughness R_a of said at least a portion of the exposed surface of the floor is less than or equal to 95 microinches.

[0098] In a thirteenth embodiment, the present disclosure provides a method according to any of the first to twelfth embodiments, further comprising, after step b):

[0099] c) wet abrading said at least a portion of the exposed surface of the floor with third structured abrasive members affixed to a third compressible resilient machine driver pad, the third structured abrasive members comprising third shaped abrasive composites affixed to a third compliant backing, wherein the third shaped abrasive composites comprise third abrasive particles dispersed in a third polymeric binder, wherein the third abrasive particles have a third average particle size, and wherein the third average particle size is less than the second average particle size; and

[0100] wherein the average surface roughness R_a of said at least a portion of the exposed surface of the floor decreases during step c).

[0101] In a fourteenth embodiment, the present disclosure provides a method according to any of the first to thirteenth embodiments, wherein after step c), the abraded exposed surface of the floor has an average surface roughness of less than 80 microinches.

[0102] In a fifteenth embodiment, the present disclosure provides a method according to any of the first to fourteenth embodiments, further comprising, subsequent to step b), applying a clear polymeric finish to said at least a portion of the exposed surface of the floor.

[0103] In a sixteenth embodiment, the present disclosure provides a method of refurbishing vinyl flooring, the method comprising sequential steps:

[0104] a) wet abrading at least a portion of an exposed surface of a floor comprising vinyl composition tiles with a nonwoven abrasive member. Wherein the nonwoven abrasive member comprises a nonwoven fiber web having first abrasive particles adhered thereto by a first polymeric binder, wherein the first abrasive particles have a first average particle size;

[0105] b) wet abrading said at least a portion of the exposed surface of the floor with first structured abrasive members affixed to a first machine driver pad, the first structured abrasive members comprising first shaped abrasive composites affixed to a first compliant backing. Wherein the first shaped abrasive composites comprise second abrasive particles dispersed in a second polymeric binder, wherein the second

abrasive particles have a second average particle size that is smaller than the first average particle size; and

[0106] c) wet abrading said at least a portion of the exposed surface of the floor with second structured abrasive members affixed to a second machine driver pad, the second structured abrasive members comprising second shaped abrasive composites affixed to a second compliant backing, wherein the second shaped abrasive composites comprise third abrasive particles dispersed in a third polymeric binder, wherein the third abrasive particles have a third average particle size, and Wherein the third average particle size is less than the second average particle size; and

[0107] wherein average surface roughness R_a of the abraded exposed surface of the floor decreases during each of steps b) and e).

[0108] In a seventeenth embodiment, the present disclosure provides a method according to the sixteenth embodiment, wherein the nonwoven abrasive member comprises a floor finish stripping pad.

[0109] In an eighteenth embodiment, the present disclosure provides a method according to the sixteenth or seventeenth embodiment, wherein average surface roughness R_z of said at least a portion of the exposed surface of the floor decreases during each of steps a) and b).

[0110] In a nineteenth embodiment, the present disclosure provides a method according to any of the sixteenth to eighteenth embodiments, wherein each of the first structured abrasive members further comprise a first compliant foam layer secured to the first compliant backing, and an attachment interface system having a plurality of hooks opposite the first compliant foam layer.

[0111] In a twentieth embodiment, the present disclosure provides a method according to any of the sixteenth to nineteenth embodiments, wherein each of the second structured abrasive members further comprise a second compliant foam layer secured to the second compliant backing, and an attachment interface system having a plurality of hooks opposite the second compliant foam layer.

[0112] In a twenty-first embodiment, the present disclosure provides a method according to any of the sixteenth to twentieth embodiments, wherein each of the first structured abrasive members further comprise a first attachment interface system secured to the first compliant backing, the first attachment interface system having a plurality of loops opposite the first compliant backing, wherein the first structured abrasive members are affixed to the first machine driver pad by a first attachment interface member having two opposed major faces having hooks extending therefrom.

[0113] In a twenty-second embodiment, the present disclosure provides a method according to any of the sixteenth to twenty-first embodiments, wherein each of the second structured abrasive members further comprises a second attachment interface system secured to the second compliant backing, the second attachment interface system having a plurality of loops opposite the second compliant backing, wherein the second structured abrasive members are affixed to the second machine driver pad by an attachment interface member having two opposed major faces having hooks extending therefrom.

[0114] In a twenty-third embodiment, the present disclosure provides a method according to any of the sixteenth to twenty-second embodiments, wherein the first and second machine driver pads are compressible and resilient.

[0115] In a twenty-fourth embodiment, the present disclosure provides a method according to any of the sixteenth to twenty-third embodiments, wherein the first shaped abrasive composites, the second shaped abrasive composites, or both, are precisely-shaped.

[0116] In a twenty-fifth embodiment, the present disclosure provides a method according to any of the sixteenth to twenty-fourth embodiments, wherein the second average particle size is in a range of from 400 microns to 600 microns.

[0117] In a twenty-sixth embodiment, the present disclosure provides a method according to any of the sixteenth to twenty-fifth embodiments, wherein the third average particle size is in a range of from 25 microns to 75 microns.

[0118] In a twenty-seventh embodiment, the present disclosure provides a method according to any of the sixteenth to twenty-sixth embodiments, wherein at least one of the first or second shaped abrasive composites comprises superabrasive particles retained in a vitreous binder.

[0119] In a twenty-eighth embodiment, the present disclosure provides a method according to any of the sixteenth to twenty-seventh embodiments, wherein after step c) the average surface roughness R_a of the abraded exposed surface of the floor is less than or equal to 2.4 microns.

[0120] In a twenty-ninth embodiment, the present disclosure provides a method according to any of the sixteenth to twenty-eighth embodiments, further comprising, after step c):

[0121] d) wet abrading said at least a portion of the exposed surface of the floor with third structured abrasive members affixed to a third compressible resilient machine driver pad, the third structured abrasive members comprising third shaped abrasive composites affixed to a third compliant backing, wherein the third shaped abrasive composites comprise fourth abrasive particles dispersed in a fourth polymeric binder, wherein the fourth abrasive particles have a fourth average particle size, and wherein the fourth average particle size is less than the third average particle size; and

[0122] where the average surface roughness R_a of said at least a portion of the exposed surface of the floor decreases during step d).

[0123] In a thirtieth embodiment, the present disclosure provides a method according to any of the sixteenth to twenty-ninth embodiments, wherein after step d), the average surface roughness R_a of said at least a portion of the exposed surface of the floor is less than or equal to 80 microinches.

[0124] In a thirty-first embodiment, the present disclosure provides a method according to any of the sixteenth to thirtieth embodiments, further comprising, subsequent to step c), applying a clear polymeric finish to said at least a portion of the exposed surface of the floor.

[0125] Objects and advantages of this disclosure are further illustrated by the following non-limiting examples, but the particular materials and amounts thereof recited in these examples, as well as other conditions and details, should not be construed to unduly limit this disclosure.

EXAMPLES

[0126] Unless otherwise noted, all parts, percentages, ratios, etc. in the Examples and the rest of the specification are by weight.

Materials Used in the Examples

[0127] 3M SCOTCHGARD VINYL FLOOR PROTECTOR is an aqueous mixture of a polymer and nano-sized, inorganic particles, designed for use as a floor protector from 3M Company.

[0128] "T300" refers to a 5-inch (13-centimeter) diameter 300- μ m diamond structured abrasive disc, having microreplicated composite diamond abrasive structures on a flexible cloth backing, supplied with a 3M hook mounting disc, and obtained under the trade designation "3M TRIZACT DIAMOND HX GOLD" from 3M Company.

[0129] "T45" refers to a 5-inch (13-centimeter) diameter 45- μ m diamond structured abrasive disc, having microreplicated composite diamond abrasive structures on a flexible cloth backing, supplied with a 3M hook mounting disc, and obtained under the trade designation "3M TRIZACT DIAMOND FIX RED" from 3M Company.

[0130] "T10" refers to a 5-inch (13-centimeter) diameter 10- μ m diamond structured abrasive disc, having microreplicated composite diamond abrasive structures on a flexible cloth backing, supplied with a 3M hook mounting disc, and obtained under the trade designation "3M TRIZACT DIAMOND HX BLUE" from 3M Company.

[0131] "T6" refers to a 5-inch (13-centimeter) diameter 6- μ m diamond structured abrasive disc, having microreplicated composite diamond abrasive structures on a 5-mil (130-micron) film laminated to a polycarbonate backing, obtained under the trade designation "3M TRIZACT 673LA grade A6" from 3M Company.

[0132] "T3" refers to a 5-inch (13-centimeter) diameter 3- μ m diamond structured abrasive disc, having microreplicated composite diamond abrasive structures on a 5-mil (130-micron) film laminated to a polycarbonate backing, "3M TRIZACT 673LA grade A3" from 3M Company.

[0133] "PDP" refers to a 20-inch (43-centimeter) diameter diamond abrasive nonwoven floor polishing pad, obtained under the trade designation "3M SCOTCH-BRITE PURPLE DIAMOND FLOOR PAD PLUS" from 3M Company.

[0134] "WSP1" refers to a 17-inch (43-centimeter) diameter nonwoven floor polishing pad, obtained under the trade designation "3M WHITE SUPERPOLISH PAD 4100" from 3M Company.

[0135] "WSP2" refers to a 20-inch (43-centimeter) diameter nonwoven floor polishing pad, obtained under the trade designation "3M WHITE SUPERPOLISH PAD 4100" from 3M Company.

Test Methods

Surface Roughness Measurement

[0136] The surface roughness of the vinyl composite (VC) tile is defined by R_z and R_a . The R_a of a surface is the measurement of the arithmetic average of the scratch depth. It is the average of 5 individual roughness depths of five successive measuring lengths, where an individual roughness depth is the vertical distance between the highest point and a center line. R_z is the average of 5 individual roughness depths of a measuring length, where an individual roughness depth is the vertical distance between the highest point and the lowest point. Surface roughness data reported in Table 1 are the average of six measurements taken on six VC tile specimens,

using a profilometer, available under the trade designation “SURTRONIC 25 PROFILOMETER” from Taylor Hobson, Inc., Leicester, England.

Gloss Measurement

[0137] The gloss of the VC tile samples was measured at angles of 20, 60 and 85 degrees using a gloss meter, model “4430”, obtained from BYK-Gardner, Columbia, Md. Gloss data reported in Tables 1 and 2 are the average of six measurements taken on six VC tile specimens.

Dry Static Coefficient of Friction (DSCF) Measurement

[0138] The Dry Static Coefficient of Friction (DSCF) of VC tile was measured using a tribometer, model “BOT-3000”, obtained from Regan Scientific Instruments, Inc., Southlake, Tex. DSCF data reported in Tables 1 and 2 are the average of four measurements taken on one VC tile specimen.

[0139] In Examples 1-10 and Comparative Examples B-D, when using diamond structured abrasive discs to abrade the floor, the process was carried out in the presence of water as applied by a string mop. The resultant abrasive slurry was removed from the surface of the floor after completing wet abrading step(s) with each type of diamond structured abrasive disc. High speed burnishing was carried out dry.

Examples 1-2

[0140] A 6 feet by 5 feet (1.83 meters by 1.52 meters) area of worn vinyl composition floor tile that had been subjected to frequent pedestrian traffic over several months was subjected to the following abrading steps.

[0141] An interface pad having hooks on both surfaces, supplied with the diamond structured abrasive discs (above)

was attached to a swing-type floor machine equipped with a WSP1. machine driver pad which operates at 175 revolutions per minute. Four T300 discs were then attached to the interface pad and the test area honed four times with the floor machine at 88 ft/min (26.82 meters/min). Surface finish, gloss and dry static coefficient of friction values were then measured. The T300 discs were replaced with T45 discs and the process repeated, after which the surface finish, gloss and dry static coefficient of friction values were again measured. The abrading process continued using successively finer T10 abrading discs. Surface finish, gloss and dry static coefficient of friction values were measured after each abrading step.

[0142] Half of the test area was marked off and designated “E-1” for Example 1, and the other half designated “E-2” for Example 2. The T10 abrading discs were replaced with T6 discs and the Area E-2 abraded four times with the floor machine at 88 ft/min (26.82 meters/min). The T6 discs were then replaced with T3 discs and area E-2 was again abraded in the same manner. The entire test areas of E-1 and E-2 were then burnished by six passes using a high speed burnisher, model “SPEEDSHINE 2000”, Obtained Tennant Trend, Inc., Holland, Mich., with a PDP floor abrading pad, at 88 ft/min (26.82 meters/min) (1st PDP step). A vinyl composition tile protector, trade designation “3M SCOTCHGARD VINYL FLOOR PROTECTOR” from 3M Company, was applied to the burnished area using a “3MEASY SHINE APPLICATOR SYSTEM” and the burnishing step repeated (2nd PDP step), followed by six passes with a WSP2 floor pad (1st WSP step). The entire test area was again coated with the vinyl floor protector, then burnished again with the PDP and the WSP floor pads as described above (3rd PDP and 2nd WSP steps, respectively). Surface finish, gloss and dry static coefficient of friction values were then measured for both areas E-1 and E-2. Results are reported in Table 1 (below).

TABLE 1

	ABRADING STEP					
	SURFACE FINISH		GLOSS, gloss units			DSCF
	R _a	R _z	20	60	85	
	microinches (microns)	microinches (microns)	degree	degree	degree	
EXAMPLE 1						
T300	98.5 (2.50)	585 (14.86)	1.0	2.3	3.5	0.68
T45	77.0 (1.96)	520 (13.21)	1.1	3.1	10.7	0.65
T10	60.7 (1.54)	454 (11.53)	1.3	5.7	31.0	0.62
1 st PDP	47.4 (1.20)	403 (10.24)	14.8	42.4	60.7	0.55
2 nd PDP	30.2 (0.77)	314 (7.98)	21.6	55.0	72.6	NM
1 st WSP	NM	NM	23.9	55.6	70.2	NM
3 rd PDP	19.8 (0.50)	179 (4.55)	20.9	58.4	79.5	0.70
2 nd WSP	NM	NM	27.4	63.7	78.2	NM
EXAMPLE 2						
T300	98.5 (2.50)	585 (14.86)	1.0	2.3	3.5	0.68
T45	77.0 (1.96)	520 (13.21)	1.1	3.1	10.7	0.65
T10	60.7 (1.54)	454 (11.53)	1.3	5.7	31.0	0.62
T6	37.5 (0.95)	335 (8.51)	2.7	14.2	50.2	0.61
T3	35.7 (0.91)	330 (8.38)	5.2	19.7	53.7	0.58
1 st PDP	33.7 (0.86)	316 (8.03)	21.2	47.7	67.0	0.59
2 nd PDP	17.0 (0.43)	193 (4.90)	28.3	58.9	74.8	NM
1 st WSP	NM	NM	33.1	63.3	76.3	NM
3 rd PDP	7.9 (0.20)	81 (2.06)	30.5	62.1	81.9	0.72
2 nd WSP	NM	NM	41.1	70.6	82.1	NM

Example 3 and Comparative Example A

[0143] These examples were carried out using a vinyl composition tile floor in a laboratory building. The floor area was stripped and rinsed. A separate area of the same floor was used for each example. Example 3 used structured abrasive discs to prepare the floor for coating with 3M SCOTCHGARD VINYL FLOOR PROTECTOR as described below. Com-

parative Example A used the floor preparation procedure outlined in the 3M SCOTCHGARD VINYL FLOOR PROTECTOR Technical Data sheet (dated February 2011) to prepare the floor. After floor preparation, both examples followed the 3M SCOTCHGARD VINYL FLOOR PROTECTOR Technical Data sheet (dated February 2011) application procedure.

Perthometer M1 profilometer from Mahr Federal, Inc., Providence, R.I., was used to measure surface roughness, R_a and R_z . An Elcometer 6015 NOVO-GLOSS Q DOI haze meter (Elcometer, Inc., Rochester Hills, Mich.) was used to measure distinctness of image (DOI), haze, and peak specular reflectance (R_{spec}). Measurements were taken from four different locations in each abraded testing area. The averages of these measurements are shown in Table 2 (below).

TABLE 2

	20° GLOSS, gloss units	60° GLOSS, gloss units	DOI value (0-100 scale)	R_{spec} , gloss units	HAZE, haze units	R_a , microinches (microns)	R_z , microinches (microns)
Initial Floor Condition	1.2	4.6	0.0	0.3	1.1	72.2 (1.83)	520.3 (13.22)
Example 3	55.8	85.3	87.0	46.3	3.9	5.9 (0.15)	47.8 (1.21)
Comparative Example A	30.7	72.4	38.8	12.0	14.0	20.8 (0.53)	160.5 (4.07)

parative Example A used the floor preparation procedure outlined in the 3M SCOTCHGARD VINYL FLOOR PROTECTOR Technical Data sheet (dated February 2011) to prepare the floor. After floor preparation, both examples followed the 3M SCOTCHGARD VINYL FLOOR PROTECTOR Technical Data sheet (dated February 2011) application procedure.

[0144] For Example 3, the floor was treated as follows:

[0145] 1. 4 passes with T300 diamond structured abrasive discs

[0146] 2. 4 passes with T45 diamond structured abrasive discs

[0147] 3. 4 passes with T10 diamond structured abrasive discs

[0148] 4. 4 passes with T6 diamond structured abrasive discs

[0149] 5. 4 passes with T3 diamond structured abrasive discs

[0150] 6. 1st coat of 3M SCOTCHGARD VINYL FLOOR PROTECTOR floor finish from 3M Company.

[0151] 7. Burnish with PDP polishing pad

[0152] 8. Burnish with WSP polishing pad

[0153] 9. 2nd coat of 3M SCOTCHGARD VINYL FLOOR PROTECTOR floor finish

[0154] 10. Burnish with PDP polishing pad

[0155] 11. Burnish with WSP polishing pad

[0156] For Comparative Example A, the floor was treated as follows:

[0157] 1. Burnish with 3M SCOTCH-BRITE SIENNA DIAMOND FLOOR PAD PLUS polishing pad, 3M Company

[0158] 2. Burnish with PDP

[0159] 3. coat of 3M SCOTCHGARD VINYL FLOOR PROTECTOR floor finish

[0160] 4. Burnish with PDP

[0161] 5. Burnish with WSP

[0162] 6. 2nd coat of 3M SCOTCHGARD VINYL FLOOR PROTECTOR floor finish

[0163] 7. Burnish with PDP polishing pad

[0164] 8. Burnish with WSP polishing pad

[0165] A BYK-Gardner gloss meter (BYK-Gardner, Columbia, Md.) was used to measure 20° and 60° gloss. A

Examples 4-10 and Comparative Examples B-D

[0166] These examples were carried out on a vinyl composition tile floor in a laboratory building. The floor area was stripped and rinsed. A separate area of the same floor was used for each example. Examples 4-10 and Comparative Examples B-C used structured abrasive discs in different combinations to prepare the floor for coating with 3M SCOTCHGARD VINYL FLOOR PROTECTOR floor finish, whereas Comparative Example D only burnished the floor with a PDP floor pad to prepare the floor. After floor preparation, all examples followed the 3M SCOTCHGARD VINYL FLOOR PROTECTOR Technical Data sheet (dated February 2011) application procedure.

Example 4

[0167] 1. Four passes with T45 diamond structured abrasive discs

[0168] 2. Four passes with T10 diamond structured abrasive discs

[0169] 3. Burnish with PDP polishing pad

Example 5

[0170] 1. Four passes with T300 diamond structured abrasive discs

[0171] 2. Four passes with T45 diamond structured abrasive discs

[0172] 3. Four passes with T10 diamond structured abrasive discs

[0173] 4. Burnish with PDP polishing pad

Example 6

[0174] 1. Four passes with T300 diamond structured abrasive discs

[0175] 2. Four passes with T10 diamond structured abrasive discs

[0176] 3. Burnish with PDP polishing pad

Comparative Example B

[0177] 1. Four passes with T300 diamond structured abrasive discs

[0178] 2. Burnish with PDP polishing pad

Example 7

- [0179] 1. Four passes with T45 diamond structured abrasive discs
- [0180] 2. Four passes with T10 diamond structured abrasive discs
- [0181] 3. Burnish with PDP polishing pad

Comparative Example C

- [0182] 1. Four passes with T45 diamond structured abrasive discs
- [0183] 2. Burnish with PDP polishing pad

Example 8

- [0184] 1. Four passes with T300 diamond structured abrasive discs

- [0193] 3. Four passes with T10 diamond structured abrasive discs

- [0194] 4. Four passes with T6 diamond structured abrasive discs

- [0195] 5. Four passes with T3 diamond structured abrasive discs

Comparative Example D

- [0196] 1. Burnish with PDP polishing pad
- [0197] Measurements were made at six different locations in each abraded test floor area. The averages of these measurements are shown in Table 3 (below).

TABLE 3

	20° GLOSS, gloss units	60° GLOSS, gloss units	DOI value (0-100 scale)	R _{spec} gloss units	HAZE, haze units	R _a microinches (microns)	R _v microinches (microns)
Initial Floor Condition	1.1	4.6	0.0	0.3	0.8	117.3 (2.98)	736.1 (18.70)
Example 4	32.8	57.3	59.5	14.5	8.4	33.7 (0.86)	258.0 (6.55)
Example 5	32.9	56.5	59.4	14.2	8.3	32.8 (0.83)	222.3 (5.65)
Example 6	25.4	51.1	51.3	10.6	9.4	33.9 (0.86)	214.2 (5.44)
Comparative Example B	15.9	42.9	34.7	5.6	12.1	63.8 (1.62)	382.2 (9.71)
Example 7	35.8	59.8	60.6	14.5	7.9	28.8 (0.73)	221.8 (5.63)
Comparative Example C	24.7	50.3	51.7	9.3	10.2	51.3 (1.30)	342.0 (8.69)
Example 8	30.2	56.1	64.0	15.1	8.1	44.7 (1.14)	319.2 (8.11)
Example 9	35.1	59.7	62.1	19.6	7.0	27.6 (0.70)	236.7 (6.01)
Example 10	37.1	60.2	68.6	21.2	5.8	22.3 (0.57)	192.7 (4.89)
Comparative Example D	11.2	35.6	27.3	3.3	13.9	65.9 (1.67)	371.2 (9.43)

- [0185] 2. Four passes with T45 diamond structured abrasive discs
- [0186] 3. Four passes with T10 diamond structured abrasive discs

Example 9

- [0187] 1. Four passes with T300 diamond structured abrasive discs
- [0188] 2. Four passes with T45 diamond structured abrasive discs
- [0189] 3. Four passes with T10 diamond structured abrasive discs
- [0190] 4. Four passes with T6 diamond structured abrasive discs

Example 10

- [0191] 1. Four passes with T300 diamond structured abrasive discs
- [0192] 2. Four passes with T45 diamond structured abrasive discs

[0198] All patents and publications referred to herein are hereby incorporated by reference in their entirety. All examples given herein are to be considered non-limiting unless otherwise indicated. Various modifications and alterations of this disclosure may be made by those skilled in the art without departing from the scope and spirit of this disclosure, and it should be understood that this disclosure is not to be unduly limited to the illustrative embodiments set forth herein.

What is claimed is:

1. A method of refurbishing vinyl composition tile flooring, the method comprising sequential steps:
 - wet abrading at least a portion of an exposed surface of a floor comprising vinyl composition tiles with first structured abrasive members affixed to a first machine driver pad, the first structured abrasive members comprising first shaped abrasive composites affixed to a first compliant backing, wherein the first shaped abrasive composites comprise first abrasive particles dispersed in a first polymeric binder, wherein the first abrasive particles have a first average particle size; and
 - b) wet abrading said at least a portion of the exposed surface of the floor with second structured abrasive members affixed to a second machine driver pad, the

second structured abrasive members comprising second shaped abrasive composites affixed to a second compliant backing, wherein the second shaped abrasive composites comprise second abrasive particles dispersed in a second polymeric binder, wherein the second abrasive particles have a second average particle size, and wherein the second average particle size is less than the first average particle size; and

wherein average surface roughness R_a of said at least a portion of the exposed surface of the floor decreases during each of steps a) and b).

2. The method of claim 1, wherein average surface roughness R_z of said at least a portion of the exposed surface of the floor decreases during each of steps a) and b).

3. The method of claim 1, wherein each of the first structured abrasive members further comprise a first attachment interface system secured to the first compliant backing, the first attachment interface system having a plurality of loops opposite the first compliant backing, wherein the first structured abrasive members are affixed to the first machine driver pad by a first attachment interface member having two opposed major faces having hooks extending therefrom.

4. The method of claim 1, wherein each of the first structured abrasive members further comprise a compliant foam layer secured to the first compliant backing, and an attachment interface system having a plurality of hooks opposite the compliant foam layer.

5. The method of claim 1, wherein each of the second structured abrasive members further comprise a compliant foam layer secured to the second compliant backing, and an attachment interface system having a plurality of hooks opposite the compliant foam layer.

6. The method of claim 1 wherein each of the second structured abrasive members further comprises a second attachment interface system secured to the second compliant backing, the second attachment interface system having a plurality of loops opposite the second compliant backing, wherein the second structured abrasive members are affixed to the second machine driver pad by an attachment interface member having two opposed major faces having hooks extending therefrom.

7. The method of claim 6, wherein the first and second machine driver pads are compressible and resilient.

8. The method of claim 1, wherein the first shaped abrasive composites, the second shaped abrasive composites, or both, are precisely-shaped.

9. The method of claim 1, wherein the average particle size is in a range of from 400 microns to 600 microns.

10. The method of claim 1, wherein the second average particle size is in a range of from 25 microns to 75 microns.

11. The method of claim 1, wherein at least one of the first or second shaped abrasive composites comprises superabrasive particles retained in a vitreous binder.

12. The method of claim 1, wherein after step b) the average surface roughness R_a of said at least a portion of the exposed surface of the floor is less than or equal to 95 micro-inches.

13. The method of claim 1, further comprising, after step b):

c) wet abrading said at least a portion of the exposed surface of the floor with third structured abrasive members affixed to a third compressible resilient machine driver pad, the third structured abrasive members comprising third shaped abrasive composites affixed to a

third compliant backing, wherein the third shaped abrasive composites comprise third abrasive particles dispersed in a third polymeric binder, wherein the third abrasive particles have a third average particle size, and wherein the third average particle size is less than the second average particle size; and

wherein the average surface roughness R_a of said at least a portion of the exposed surface of the floor decreases during step c).

14. The method of claim 13, wherein after step c), the abraded exposed surface of the floor has an average surface roughness of less than 80 microinches.

15. The method of claim 1, further comprising, subsequent to step b), applying a clear polymeric finish to said at least a portion of the exposed surface of the floor.

16. A method of refurbishing vinyl flooring, the method comprising sequential steps:

a) wet abrading at least a portion of an exposed surface of a floor comprising vinyl composition tiles with a nonwoven abrasive member, wherein the nonwoven abrasive member comprises a nonwoven fiber web having first abrasive particles adhered thereto by a first polymeric binder, wherein the first abrasive particles have a first average particle size;

b) wet abrading said at least a portion of the exposed surface of the floor with first structured abrasive members affixed to a first machine driver pad, the first structured abrasive members comprising first shaped abrasive composites affixed to a first compliant backing, wherein the first shaped abrasive composites comprise second abrasive particles dispersed in a second polymeric binder, wherein the second abrasive particles have a second average particle size that is smaller than the first average particle size; and

c) wet abrading said at least a portion of the exposed surface of the floor with second structured abrasive members affixed to a second machine driver pad, the second structured abrasive members comprising second shaped abrasive composites affixed to a second compliant backing, wherein the second shaped abrasive composites comprise third abrasive particles dispersed in a third polymeric binder, wherein the third abrasive particles have a third average particle size, and wherein the third average particle size is less than the second average particle size; and

wherein average surface roughness R_a of the abraded exposed surface of the floor decreases during each of steps b) and c).

17. The method of claim 16, wherein the nonwoven abrasive member comprises a floor finish stripping pad.

18. The method of claim 17, wherein average surface roughness R_z of said at least a portion of the exposed surface of the floor decreases during each of steps a) and b).

19. The method of claim 16, wherein each of the first structured abrasive members further comprise a compliant foam layer secured to the first compliant backing, and an attachment interface system having a plurality of hooks opposite the compliant foam layer.

20. The method of claim 16, wherein each of the second structured abrasive members further comprise a compliant foam layer secured to the second compliant backing, and an attachment interface system having a plurality of hooks opposite the compliant foam layer.

21. The method of claim **16**, wherein each of the first structured abrasive members further comprise a first attachment interface system secured to the first compliant backing, the first attachment interface system having a plurality of loops opposite the first compliant backing, wherein the first structured abrasive members are affixed to the first machine driver pad by a first attachment interface member having two opposed major faces having hooks extending therefrom.

22. The method of claim **16**, wherein each of the second structured abrasive members further comprises a second attachment interface system secured to the second compliant backing, the second attachment interface system having a plurality of loops opposite the second compliant backing, wherein the second structured abrasive members are affixed to the second machine driver pad by an attachment interface member having two opposed major faces having hooks extending therefrom.

23. The method of claim **16**, wherein the first and second machine driver pads are compressible and resilient.

24. The method of claim **16**, wherein the first shaped abrasive composites, the second shaped abrasive composites, or both, are precisely-shaped.

25. The method of claim **16**, wherein the second average particle size is in a range of from 400 microns to 600 microns.

26. The method of claim **16**, wherein the third average particle size is in a range of from 25 microns to 75 microns.

27. The method of claim **16**, wherein at least one of the first or second shaped abrasive composites comprises superabrasive particles retained in a vitreous binder.

28. The method of claim **16**, wherein after step c) the average surface roughness R_a of the abraded exposed surface of the floor is less than or equal to 2.4 microns.

29. The method of claim **16**, further comprising, after step c):

d) wet abrading said at least a portion of the exposed surface of the floor with third structured abrasive members affixed to a third compressible resilient machine driver pad, the third structured abrasive members comprising third shaped abrasive composites affixed to a third compliant backing, wherein the third shaped abrasive composites comprise fourth abrasive particles dispersed in a fourth polymeric binder, wherein the fourth abrasive particles have a fourth average particle size, and wherein the fourth average particle size is less than the third average particle size; and

wherein the average surface roughness R_a of said at least a portion of the exposed surface of the floor decreases during step d).

30. The method of claim **16**, wherein after step d), the average surface roughness R_a of said at least a portion of the exposed surface of the floor is less than or equal to 80 micro-inches.

31. The method of claim **16**, further comprising, subsequent to step c), applying a clear polymeric finish to said at least a portion of the exposed surface of the floor.

* * * * *