



INTERNATIONAL APPLICATION PUBLISHED UNDER THE PATENT COOPERATION TREATY (PCT)

<p>(51) International Patent Classification 5 : B41J 2/175</p>	<p>A1</p>	<p>(11) International Publication Number: WO 94/11194 (43) International Publication Date: 26 May 1994 (26.05.94)</p>
<p>(21) International Application Number: PCT/US93/10875 (22) International Filing Date: 12 November 1993 (12.11.93) (30) Priority data: 07/975,388 12 November 1992 (12.11.92) US (71) Applicant: REPEAT-O-TYPE STENCIL MFG. CO., INC. [US/US]; 665 State Highway #23, Wayne, NJ 07470 (US). (72) Inventors: ONTAWAR, Susan, P. ; 11 Monroe Street, Vernon, NJ 07462 (US). KEEN, Fred ; 64 Oak Avenue, Tenafly, NJ 07670 (US). (74) Agent: QUAST, W., Patrick; One DeMercurio Drive, Allendale, NJ 07401 (US).</p>		<p>(81) Designated States: AU, BR, CA, DE, FI, HU, JP, KR, NO, NZ, European patent (AT, BE, CH, DE, DK, ES, FR, GB, GR, IE, IT, LU, MC, NL, PT, SE). Published <i>With international search report. Before the expiration of the time limit for amending the claims and to be republished in the event of the receipt of amendments.</i></p>

(54) Title: USER REFILLABLE INK JET CARTRIDGE AND METHOD FOR MAKING SAID CARTRIDGE

(57) Abstract

A non-refillable ink jet cartridge (10) is rendered user (34) refillable in a convenient manner. Hewlett-Packard ink jet cartridge #51626A is modified by sealing the vent hole (42) at the base (16) of the cartridge with a pressure sensitive adhesive tape (24), and removing the air tight ink fill plug (14, 20) at the top of the cartridge. After refilling with ink, a bellows type inflator bottle (48) is used to inflate bladders within the cartridge making use of an opening (44) in the cartridge. The ink fill opening (20) is re-sealed (26) either immediately before or just after the bladders (46) are inflated, and the inflator bottle (48) is then removed which releases the air pressure in the bladders causing the bladders to deflate. The deflated bladders cause an area of reduced air pressure to develop over the ink fill level, which prevents the ink from leaking out of the cartridge when the pressure sensitive adhesive tape (24) covering the vent hole at the base of the cartridge is removed.

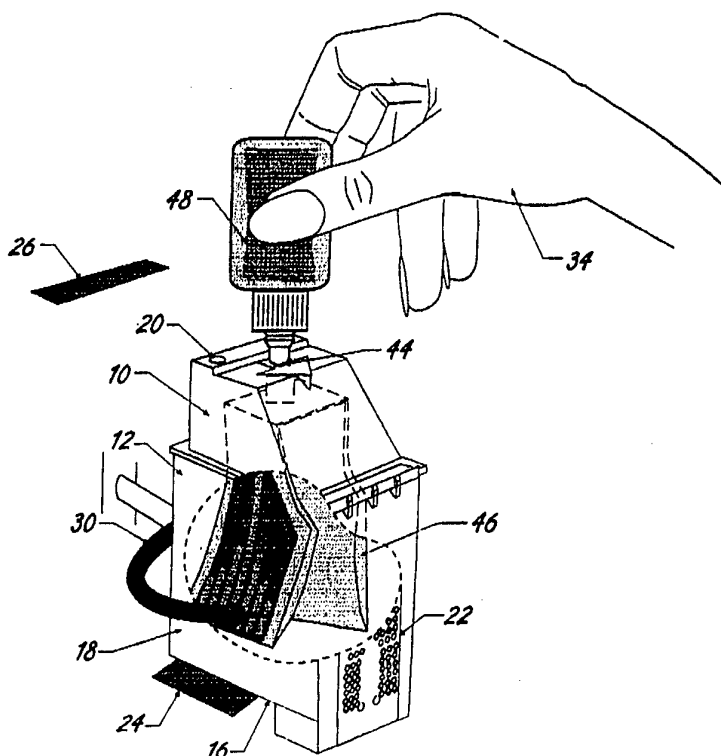

FOR THE PURPOSES OF INFORMATION ONLY

Codes used to identify States party to the PCT on the front pages of pamphlets publishing international applications under the PCT.

AT	Austria	GB	United Kingdom	MR	Mauritania
AU	Australia	GE	Georgia	MW	Malawi
BB	Barbados	GN	Guinea	NE	Niger
BE	Belgium	GR	Greece	NL	Netherlands
BF	Burkina Faso	HU	Hungary	NO	Norway
BG	Bulgaria	IE	Ireland	NZ	New Zealand
BJ	Benin	IT	Italy	PL	Poland
BR	Brazil	JP	Japan	PT	Portugal
BY	Belarus	KE	Kenya	RO	Romania
CA	Canada	KG	Kyrgystan	RU	Russian Federation
CF	Central African Republic	KP	Democratic People's Republic of Korea	SD	Sudan
CG	Congo	KR	Republic of Korea	SE	Sweden
CH	Switzerland	KZ	Kazakhstan	SI	Slovenia
CI	Côte d'Ivoire	LI	Liechtenstein	SK	Slovakia
CM	Cameroon	LK	Sri Lanka	SN	Senegal
CN	China	LU	Luxembourg	TD	Chad
CS	Czechoslovakia	LV	Latvia	TG	Togo
CZ	Czech Republic	MC	Monaco	TJ	Tajikistan
DE	Germany	MD	Republic of Moldova	TT	Trinidad and Tobago
DK	Denmark	MG	Madagascar	UA	Ukraine
ES	Spain	ML	Mali	US	United States of America
FI	Finland	MN	Mongolia	UZ	Uzbekistan
FR	France			VN	Vict Nam
GA	Gabon				

USER REFILLABLE INK JET CARTRIDGE
AND METHOD FOR MAKING SAID CARTRIDGE

BACKGROUND OF THE INVENTION

This application is a continuation in part of
5 copending application Serial Number 07/950,782, filed
September 24, 1992, now abandoned.

This invention relates to ink jet cartridges, and
in particular to user refillable ink jet cartridges.

The use of convenient single color (e.g. black) ink
10 jet cartridges for use in printing computer generated
documents and other printing devices is today standard
practice. For example, Hewlett-Packard Company (300
Hanover, P.O. Box #10301, Palo Alto, Ca. 94303-0890,
USA) has been marketing ink jet cartridge #51608A for
15 use in Hewlett-Packard Desk Jet, Deskwriter and similar
printers. This cartridge has been supplied from
Hewlett-Packard as a non-refillable, disposable ink jet
cartridge. However, for several years it has been known
that these cartridges can be rendered user refillable by
20 inserting an ink filled hypodermic needle into an air
vent in the cartridge top, and injection of enough fresh
ink into the cartridge to saturate the foam sponge
inside the cartridge.

Recently Hewlett-Packard introduced a higher
25 capacity non-refillable and disposable ink jet cartridge
#51626A for use in the same printing devices noted
above. The increased ink capacity of the new cartridge

was accomplished by sealing the air vent hole with an air tight press fit plastic plug, which is to be found at one of the four corners of the top surface of the cartridge. At the same time a set of inflatable air bladders, which do not allow direct access to the ink reservoir, have been placed within the ink jet cartridge. A hole at the top center of the cartridge provides a direct connection with the inflatable air bladders within the cartridge. Thus the new cartridge #51626A incorporates the principal of reduced air pressure in the closed chamber above the liquid ink level to prevent the ink from dripping out of the minute orifices at the bottom of the cartridge.

While these newer cartridges provide the advantage of a greater ink supply, it would still be a significant advantage to the user to be able to refill the cartridge ink supply repeatedly, thereby greatly extending the use of the cartridge, and lowering the cost of each copy produced by the cartridge. The instant invention provides a solution to this problem by disclosing a method for converting a non-refillable ink jet cartridge into a user refillable ink jet cartridge, thereby providing said refillable cartridge to users of this equipment.

SUMMARY OF THE INVENTION

Accordingly, it is a primary object of the invention to provide a refillable ink jet dispensing system.

Another object is to provide a refillable ink jet dispensing system utilizing a single ink color.

Still another object is to provide an economical ink jet dispensing system.

A further object is to permit printing a maximum number of copies with an ink jet dispensing system.

An additional object of the invention is to provide the user with means for refilling the ink supply in an ink depleted ink jet dispensing system.

The above recited and other objects are obtained in the instant invention. It has been discovered that the Hewlett-Packard cartridge #51626A can be converted into a user refillable ink jet cartridge in a convenient manner. Initially it was determined that the air tight plug at the top of this cartridge could be removed by pushing it into the cartridge. This can be accomplished in a variety of ways such as, for example, by pushing a small diameter nail into the plug. However, a preferred embodiment of the invention makes use of a cylindrically shaped rod, slightly smaller in diameter than the air tight plug, to push the plug into the interior of the cartridge. With this plug removed fresh ink can now be

added through this hole created by the removal of the plug to replenish the cartridge ink supply. Commercially available refill ink bottles, together with their commercially available filler tubes are employed to
5 refill the cartridge.

After refilling cartridge #51626A with ink the hole at its top created by the removal of the air tight plug is resealed. Many methods can be used to reseal this hole such as putting in a new plug, etc. A preferred
10 method is to place a pressure sensitive adhesive tape over this opening. Even doing this, however, does not prevent leakage from the print orifices and small vent hole at the cartridge bottom for a considerable period of time. This leakage can be prevented by: inserting a
15 soft rubber plug into the hole at the top of a just refilled #51626A cartridge, and, with a small gauge hypodermic needle inserted through this rubber plug to depth above the liquid level, sucking some of the air out of the cartridge, creating a partial vacuum.

20 Finally the following preferred method for rendering a Hewlett-Packard cartridge #51626A refillable, and refilling said cartridge was developed:

A. The cartridge is placed in a jig, and pressure sensitive tape is placed over the vent hole at the base
25 of the cartridge. [Note: The jig can consist of a

variety of simple holding devices such as a small stand, a hollow clear plastic holder, etc.]

B. A cylindrically shaped rod is used to push into the cartridge the air tight plug at the top of the
5 cartridge.

C. A commercially available ink bottle and filler tube is used to replenish the ink supply through the opening created by removal of said air tight plug.

D. A bellows type inflator bottle is employed to
10 create the reduced air pressure in the closed chamber above the liquid ink level. The inflator bottle (available from "Repeat-O-Type Corporation, 665 State H'way No.23, Wayne, N.J.07470") consists of an empty plastic squeeze bottle. The open end of the inflator
15 bottle is placed over the opening at the top of the ink jet cartridge that connects with the inflatable bladders within the cartridge. The top of the inflator bottle is pressed securely against this opening whereupon squeezing the inflator bottle between your fingers
20 causes the inflatable bladders to be inflated with air. The above procedure for inflating the bladders within the cartridge may be done with the opening at the top of the cartridge created by the removal of the air tight plug remaining open, followed by sealing this opening
25 closed after inflating the bladders by placing pressure

sensitive adhesive tape over this opening.

Alternatively, a more convenient and effective method is to seal this opening closed with said pressure sensitive adhesive tape after the cartridge is re-filled with ink, and before the bladders within the cartridge are inflated.

E. Finger pressure is now released from the inflator bottle, which causes reduced air pressure to develop over the ink level within the cartridge, preventing the ink from dripping out of the vent hole at the base of the cartridge.

F. The few drops of ink that may drip out during this refilling process can be absorbed by placing an absorbent pad, such as a cotton pad, at the base of the jig beneath the cartridge.

G. The pressure sensitive adhesive tape covering the vent hole at the base of the cartridge is now removed, and the cartridge can now be reinstalled in the printer.

BRIEF DESCRIPTION OF THE DRAWINGS

Fig. 1 is a perspective view of a non-refillable ink jet cartridge about to be modified by the method of the invention into a refillable cartridge.

Fig. 2 is a perspective view of a modified refillable ink jet cartridge, illustrating the removal of the air tight plug, with a side wall of the cartridge cut away to show the ink reservoir interior, and the inflatable bladders.

Fig. 3 illustrates a preferred procedure for refilling the ink jet cartridge of the invention.

Fig. 4 illustrates a preferred procedure for inflating the inflatable bladders, and for sealing the ink refill opening with sealing tape.

Fig. 5 illustrates the cartridge with the sealing tape in place at the ink refill hole, and at the base of the cartridge.

Fig. 6 illustrates removing sealing tape from the base of the ink refilled cartridge.

Fig. 7 illustrates the underside of the ink jet cartridge.

DETAILED DESCRIPTION OF THE PREFERRED EMBODIMENTS

Fig. 1 shows cartridge 10 connected to jig 28 by means of spring loaded clamp 30 which is connected to jig. 28. Cartridge 10 is Hewlett-Packard ink jet cartridge #51626A. Cartridge 10 is supplied by the manufacturer with an air tight plug 14 sealing opening 20 (Fig. 2), thereby rendering the cartridge non-refillable. Cartridge 10 has an upper portion 12 which contains the main ink supply in reservoir 18, and a lower portion 16 with ink dispensing orifices/ printed circuit board 22, and a vent hole 42 (Fig. 7) forming part of what applicant believes is a pressure equalizing valve. An absorbent pad 40, as, for example, an

absorbent cotton pad, is placed beneath cartridge 10 at the base of jig 28 in order to absorb the few drops of ink that may leak out of the cartridge during the ink refilling process.

5 Hand 34 (Fig. 1) is shown grasping cylindrical rod 32 while poised over plug 14. Cylindrical rod 32 has a slightly smaller diameter than does plug 14, and it is used to push plug 14 into the upper portion of 12 of the cartridge, thereby creating ink refill opening 20 (Fig.
10 2) at the top of upper portion 12. Rod 32 is preferably fabricated in metal, but can also be made out of a hard plastic, etc. Other objects can be used to dislodge plug 14, including a nail with an appropriate smaller diameter, etc. Pressure sensitive adhesive tape 24 is
15 shown already in place, secured over vent hole 42 at the base of lower portion 16.

Fig. 2 illustrates cartridge 10 now converted into a refillable ink jet cartridge with the vent hole 42 in the base of the lower portion 16 sealed closed by means
20 of pressure sensitive adhesive tape 24, and air plug 14 removed, making opening 20 accessible for use as an ink refill opening. A portion of cartridge 10 upper portion 12 is shown cut away illustrating the placement of inflatable bladders 46 within the ink reservoir 18,
25 with inflatable bladder opening 44 shown centrally located at the top of cartridge 10.

In Fig. 3 the preferred method for replenishing ink is shown. A bottle 38 (preferably a squeeze bottle) containing an appropriate ink is shown squeezed by hand 34 to cause ink to flow through filler tube 36, and then through opening 20 to reservoir 18 cartridge upper portion 12. Appropriate inks, ink bottles, and their filler tubes are commercially available and well known to the art.

Referring now to Fig. 4, once the ink supply has been replenished in reservoir 18, pressure sensitive adhesive tape 26 is placed over opening 20 in order to re-seal said opening. Other methods for sealing this opening include placing a replacement plug into hole 20, etc. The neck of bellows type inflator bottle 48 is now inserted into opening 44 (Fig. 2), and the bottle is squeezed by the fingers of hand 34, causing inflatable bladders 46 to inflate. An inflator type bottle is available from "Repeat-O-Type Corporation, 665 State H'Way No. 23, Wayne, New Jersey, 07470", and, of course, the bladders may be inflated with a variety of other types of bellows devices, or by blowing the bladders up by mouth using a rubber tube, or with compressed air, etc. The action of inflating the bladders after the opening 20 is sealed creates an increased pressure in

the cartridge, which in turn forces the ink to drip rapidly from the ink dispensing orifices/printed circuit board 22. After several second the pressure is released by removing the inflator bottle 48 from opening 44. As
5 the bladders 46 deflate they cause a reduced air pressure to develop above the liquid ink level within the upper portion 12 of cartridge 10, which prevents the ink from dripping out of the minute orifices at the bottom of the cartridge.

10 In an alternate method opening 20 in cartridge 10 can be left open while the bladders within the cartridge are being inflated. Pressure sensitive adhesive tape is then used to seal opening 20 closed, and the bladders are then deflated. Fig. 5 illustrates cartridge 10 with
15 sealing tape 26 in place on the ink re-fill opening 20, and sealing tape 24 is shown sealing opening 42 at the base of the cartridge.

Finally pressure sensitive adhesive tape 24 (Fig. 6) is peeled away from the maze at the base of the
20 cartridge 10 and vent hole 42 (Fig. 7). The cartridge may now be removed from clamp 30 on jig 28, and placed back into the printing device.

While the present invention has been disclosed in connection with the preferred embodiments shown and described in detail, various modifications and improvements thereon will become readily apparent to those skilled in the art. Accordingly, the spirit and scope of the present invention is to be limited only by the following claims.

What is claimed is:

- 1 1. A method for making a non-refillable ink jet
2 cartridge user refillable, which comprises the steps of:
3 (a) sealing a vent hole at the base of said cartridge;
4 and
5 (b) removing a plug at the top of said cartridge.
- 1 2. The method of claim 1, further comprising the step of
2 placing an absorbent pad beneath said base of said
3 cartridge.
- 1 3. The method according to claim 1, further comprising
2 the step of filling said cartridge with ink through the
3 opening created in said top of said cartridge by
4 removing said plug.
- 1 4. The method according to claim 3, further comprising
2 the step of inserting means for inflating inflatable
3 bladders within said cartridge, and inflating said
4 inflatable bladders.
- 1 5. The method according to claim 4, further comprising
2 the step of sealing said opening in said top of said
3 cartridge created by removing said plug after filling
4 said cartridge with ink.
- 1 6. The method according to claim 5 wherein the step of
2 sealing said opening occurs before the step of inflating
3 said inflatable bladders within said cartridge.

1 7. The method according to claim 5, further comprising
2 the step of removing said means for inflating said
3 inflatable bladders after the steps of filling said
4 cartridge with said ink, sealing said opening in said
5 top of said cartridge, and inflating said bladders.

1 8. The method according to claim 7, further comprising
2 the step of unsealing said vent hole at said base of
3 said cartridge.

1 9. The method according to claim 8 wherein the step of
2 unsealing said vent hole occurs after said step of
3 sealing said opening in said top of said cartridge
4 created by removing said plug.

1 10. The method according to claim 1 wherein the step of
2 removing said plug at the top of said cartridge
3 comprises the step of pushing said plug into said
4 cartridge.

1 11. The method according to claim 1, further comprising
2 the step of securing said cartridge in a jig prior to
3 said steps of (a), and (b).

1 12. The method according to claim 1 wherein said ink jet
2 cartridge is a single color ink jet cartridge.

1 13. The method according to claim 9 wherein said ink jet
2 cartridge is Hewlett-Packard ink jet cartridge #51626A.

1 14. A non-refillable ink jet cartridge rendered
2 refillable according to the method of claim 1.

1 15. An ink jet cartridge according to claim 14 wherein
2 said non-refillable ink jet cartridge is Hewlett-Packard
3 ink jet cartridge #51626A.

1 16. An ink jet cartridge according to claim 14 wherein
2 said vent hole at the base of said cartridge is sealed
3 with pressure sensitive adhesive tape.

1 17. An ink jet cartridge according to claim 14 wherein
2 said plug is removed by pushing said plug into said
3 cartridge by means of a cylindrically shaped rod.

1 18. An ink jet cartridge according to claim 14 wherein
2 said cartridge is filled with ink through an opening
3 created in said cartridge by removing said plug.

1 19. An ink jet cartridge according to claim 18 wherein
2 inflatable bladders within said cartridge are inflated
3 with air, and said opening for filling said cartridge
4 with said ink is sealed with pressure sensitive adhesive
5 tape.

1 20. An ink jet cartridge according to claim 19 wherein
2 said bladders are deflated after said opening for filling
3 said cartridge with said ink is sealed with said
4 pressure sensitive adhesive tape.

1 21. An ink jet cartridge according to claim 20 wherein
2 said vent hole at the base of said cartridge is unsealed
3 after said opening for filling said cartridge with said
4 ink is sealed.

- 1 22. An ink jet cartridge according to claim 14 wherein
2 said cartridge is secured in a jig.
- 1 23. An ink jet cartridge according to claim 22 wherein
2 an absorbent pad is placed beneath said jig.
- 1 24. A kit for rendering a Hewlett-Packard ink jet
2 cartridge #51626A user refillable, comprising:
- 3 (a) a bottle of ink;
- 4 (b) means for inserting said ink within said
5 cartridge;
- 6 (c) means for inflating bladders within said
7 cartridge with air; and
- 8 (d) means for sealing a vent hole at the base of
9 said cartridge, and for sealing an opening in said
10 cartridge through which said ink is inserted.

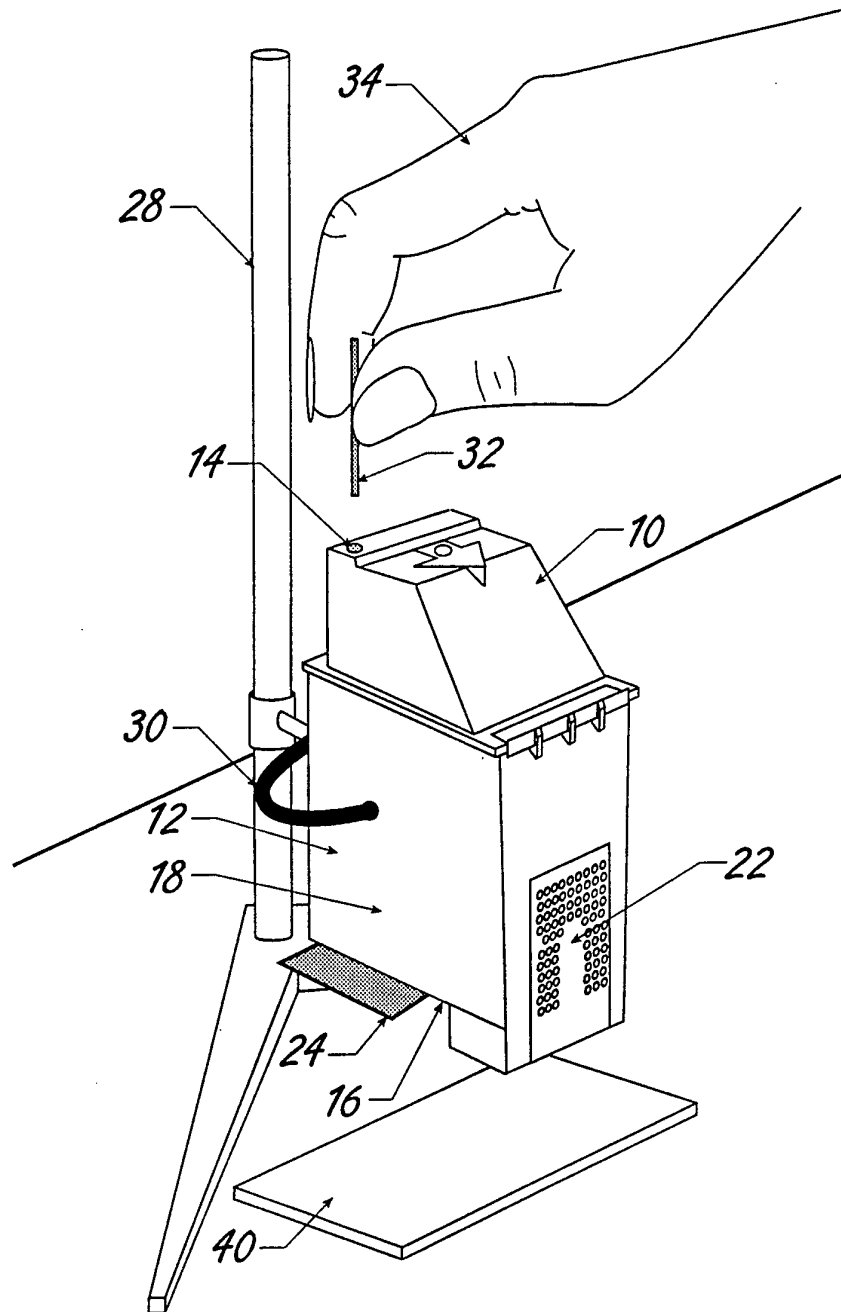

FIGURE 1

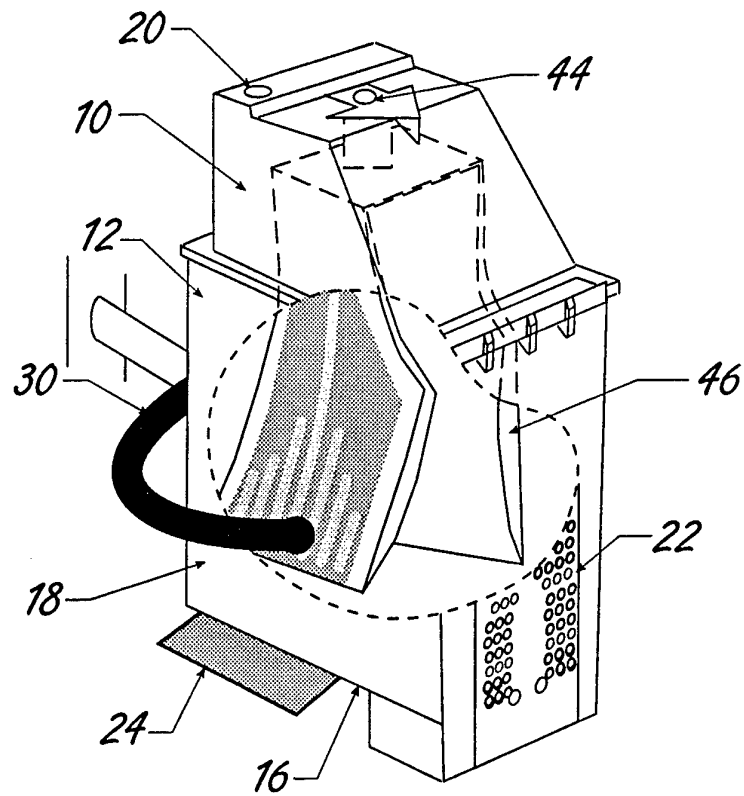

FIGURE 2

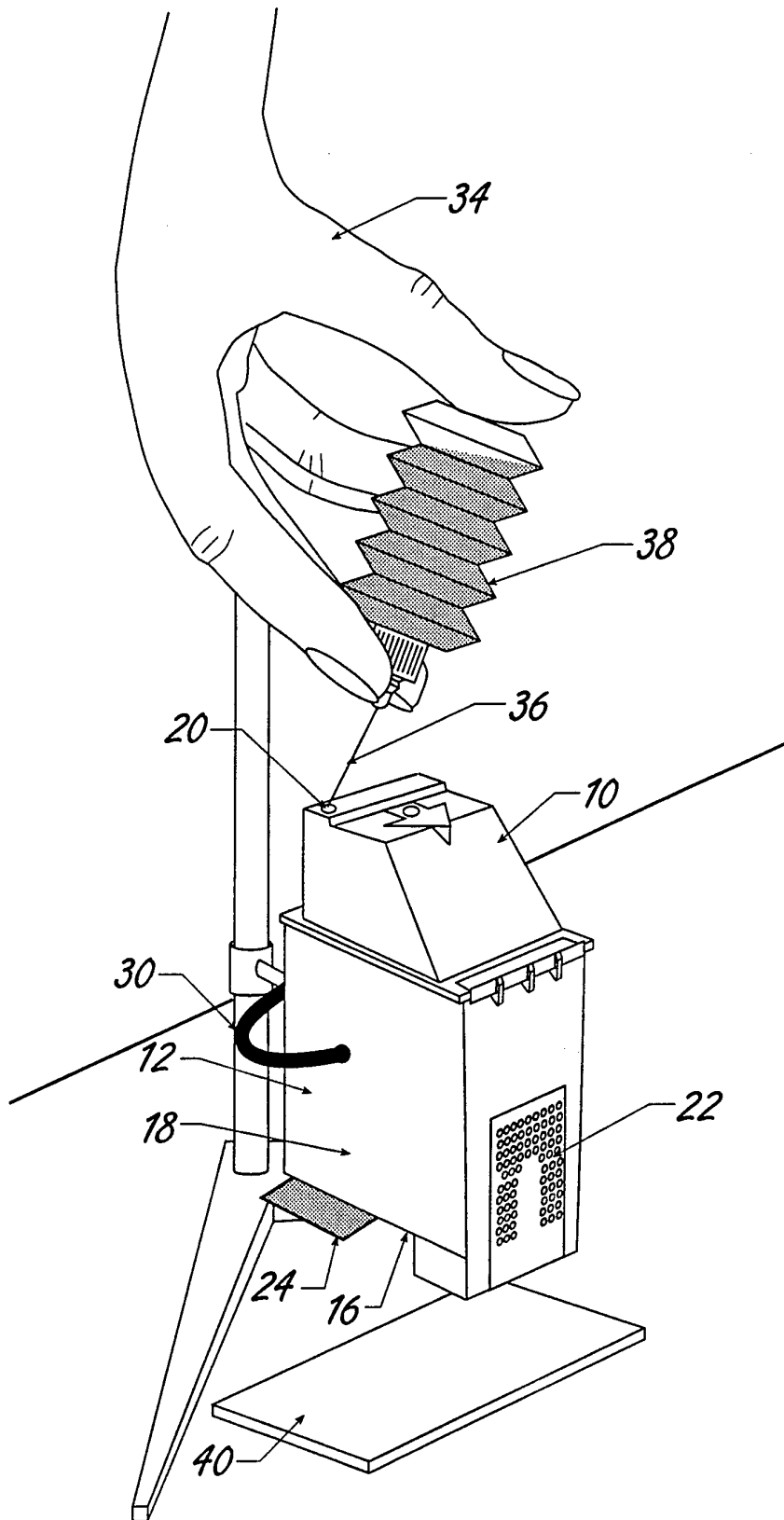

FIGURE 3

3/7

SUBSTITUTE SHEET

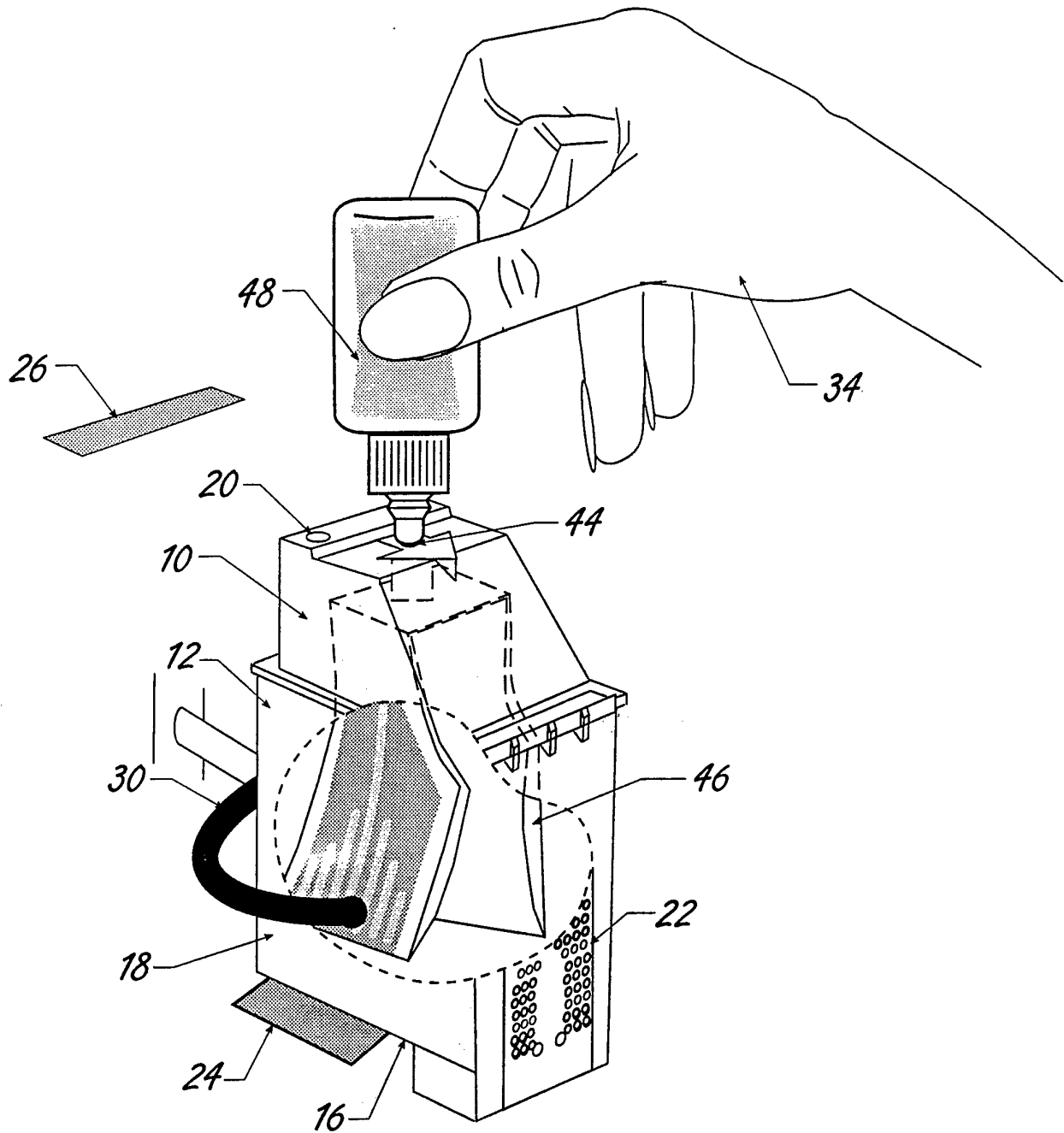

FIGURE 4

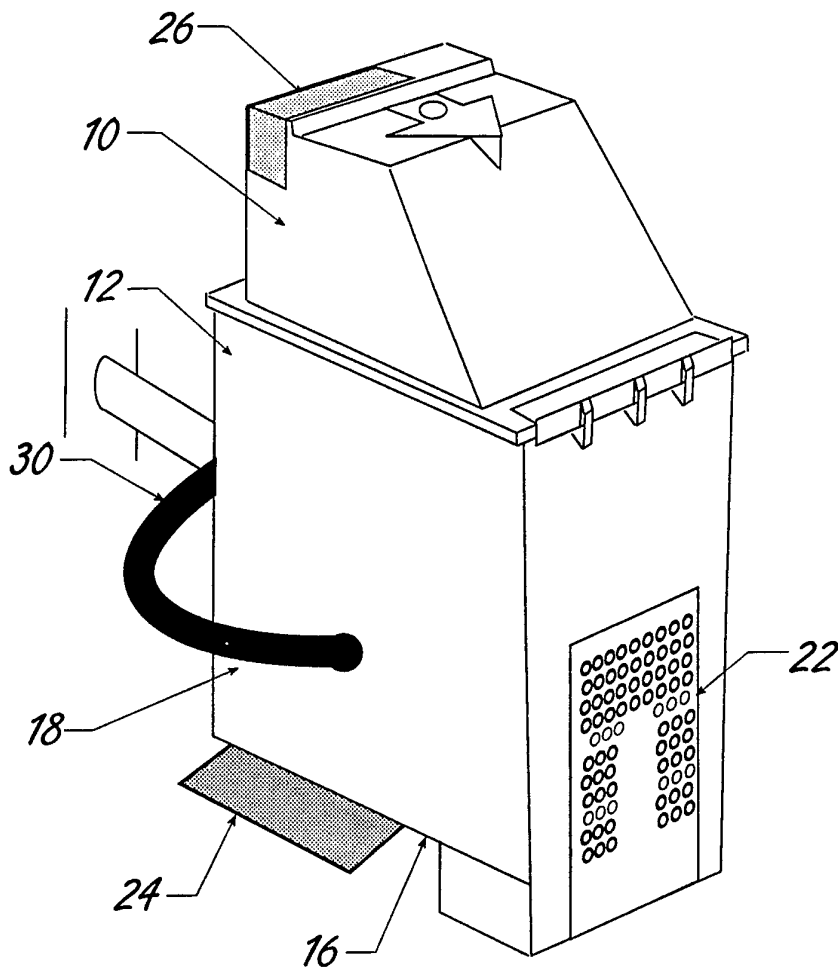

FIGURE 5

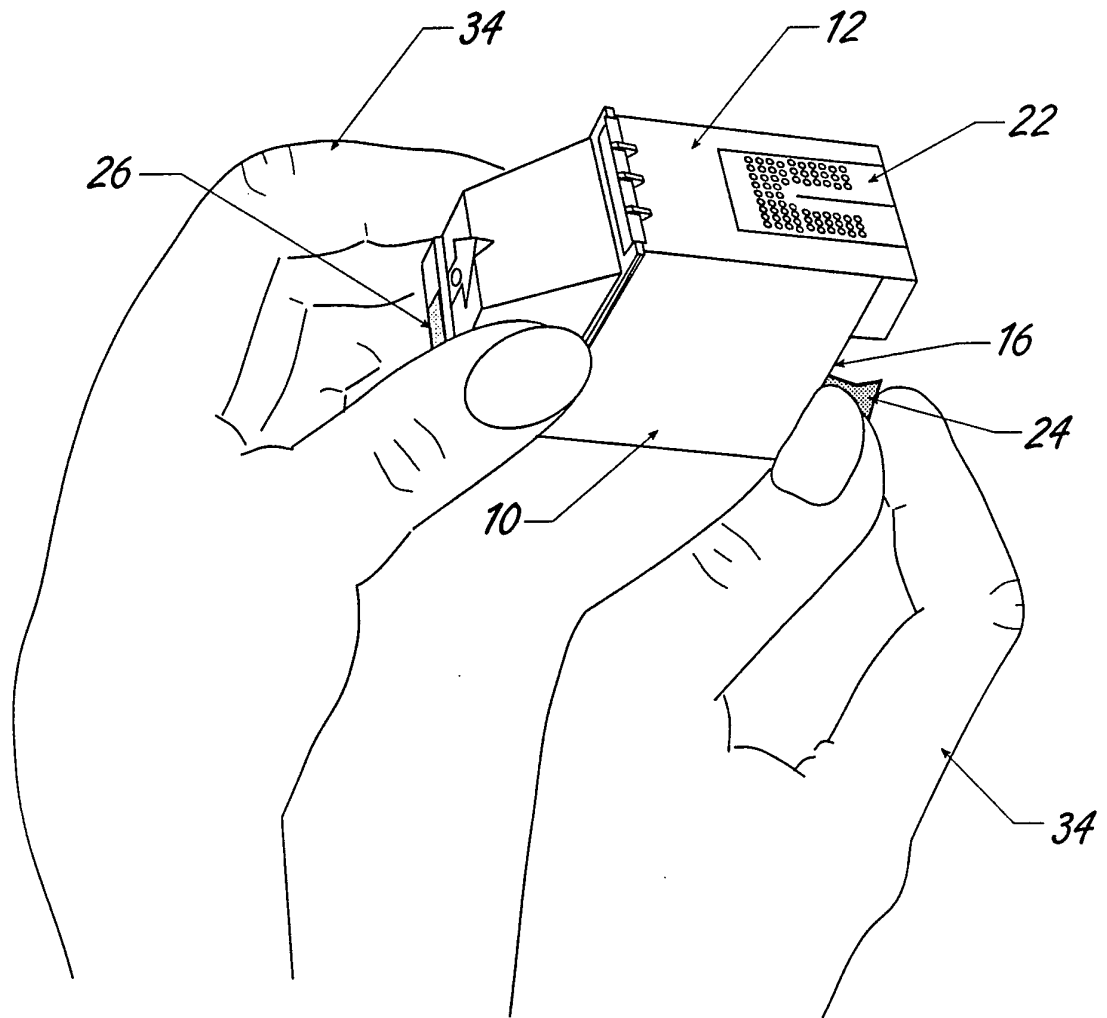
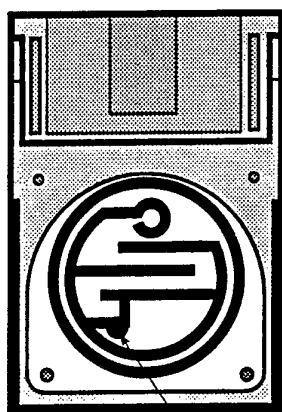

FIGURE 6



42

FIGURE 7

INTERNATIONAL SEARCH REPORT

International Application No
PCT/US 93/10875

<p>A. CLASSIFICATION OF SUBJECT MATTER IPC 5 B41J2/175</p> <p>According to International Patent Classification (IPC) or to both national classification and IPC</p>														
<p>B. FIELDS SEARCHED</p> <p>Minimum documentation searched (classification system followed by classification symbols) IPC 5 B41J</p> <p>Documentation searched other than minimum documentation to the extent that such documents are included in the fields searched</p> <p>Electronic data base consulted during the international search (name of data base and, where practical, search terms used)</p>														
<p>C. DOCUMENTS CONSIDERED TO BE RELEVANT</p> <table border="1"> <thead> <tr> <th>Category *</th> <th>Citation of document, with indication, where appropriate, of the relevant passages</th> <th>Relevant to claim No.</th> </tr> </thead> <tbody> <tr> <td>X A</td> <td>EP,A,0 568 124 (SMETS) see column 2, line 28 - column 3, line 54; figures ---</td> <td>1-3, 11-18 4,19,24</td> </tr> <tr> <td>A</td> <td>US,A,4 475 116 (SICKING ET AL.) 2 October 1984 see column 2, line 26 - line 60; figures 1,2 ---</td> <td>4,24</td> </tr> <tr> <td>A</td> <td>EP,A,0 437 363 (HEWLETT-PACKARD) 17 July 1991 see column 7, line 55 - line 58 see column 11, line 15 - line 17 see column 14, line 6 - line 48; figures --- -/--</td> <td>1,4,24</td> </tr> </tbody> </table>			Category *	Citation of document, with indication, where appropriate, of the relevant passages	Relevant to claim No.	X A	EP,A,0 568 124 (SMETS) see column 2, line 28 - column 3, line 54; figures ---	1-3, 11-18 4,19,24	A	US,A,4 475 116 (SICKING ET AL.) 2 October 1984 see column 2, line 26 - line 60; figures 1,2 ---	4,24	A	EP,A,0 437 363 (HEWLETT-PACKARD) 17 July 1991 see column 7, line 55 - line 58 see column 11, line 15 - line 17 see column 14, line 6 - line 48; figures --- -/--	1,4,24
Category *	Citation of document, with indication, where appropriate, of the relevant passages	Relevant to claim No.												
X A	EP,A,0 568 124 (SMETS) see column 2, line 28 - column 3, line 54; figures ---	1-3, 11-18 4,19,24												
A	US,A,4 475 116 (SICKING ET AL.) 2 October 1984 see column 2, line 26 - line 60; figures 1,2 ---	4,24												
A	EP,A,0 437 363 (HEWLETT-PACKARD) 17 July 1991 see column 7, line 55 - line 58 see column 11, line 15 - line 17 see column 14, line 6 - line 48; figures --- -/--	1,4,24												
<p><input checked="" type="checkbox"/> Further documents are listed in the continuation of box C. <input checked="" type="checkbox"/> Patent family members are listed in annex.</p>														
<p>* Special categories of cited documents :</p> <p>"A" document defining the general state of the art which is not considered to be of particular relevance</p> <p>"E" earlier document but published on or after the international filing date</p> <p>"L" document which may throw doubts on priority claim(s) or which is cited to establish the publication date of another citation or other special reason (as specified)</p> <p>"O" document referring to an oral disclosure, use, exhibition or other means</p> <p>"P" document published prior to the international filing date but later than the priority date claimed</p> <p>"T" later document published after the international filing date or priority date and not in conflict with the application but cited to understand the principle or theory underlying the invention</p> <p>"X" document of particular relevance; the claimed invention cannot be considered novel or cannot be considered to involve an inventive step when the document is taken alone</p> <p>"Y" document of particular relevance; the claimed invention cannot be considered to involve an inventive step when the document is combined with one or more other such documents, such combination being obvious to a person skilled in the art.</p> <p>"&" document member of the same patent family</p>														
<p>Date of the actual completion of the international search</p> <p>25 January 1994</p>		<p>Date of mailing of the international search report</p> <p>14. 03. 94</p>												
<p>Name and mailing address of the ISA</p> <p>European Patent Office, P.B. 5818 Patentlaan 2 NL - 2280 HV Rijswijk Tel. (+31-70) 340-2040, Tx. 31 651 epo nl, Fax (+31-70) 340-3016</p>		<p>Authorized officer</p> <p>De Groot, R</p>												

INTERNATIONAL SEARCH REPORT

International Application No

PCT/US 93/10875

C.(Continuation) DOCUMENTS CONSIDERED TO BE RELEVANT		
Category *	Citation of document, with indication, where appropriate, of the relevant passages	Relevant to claim No.
P,A	EP,A,0 567 308 (LEXMARK INTERNATIONAL) see column 2, line 39 - line 58; figures ---	1
A	EP,A,0 456 840 (CANON K.K.) 21 November 1991 see abstract; claims 1,3 -----	16

INTERNATIONAL SEARCH REPORT

Information on patent family members

International Application No

PCT/US 93/10875

Patent document cited in search report	Publication date	Patent family member(s)	Publication date
EP-A-0568124	03-11-93	NONE	
US-A-4475116	02-10-84	DE-A- 3137970 JP-A- 58145455	31-03-83 30-08-83
EP-A-0437363	17-07-91	JP-A- 4219252	10-08-92
EP-A-0567308	27-10-93	NONE	
EP-A-0456840	21-11-91	AU-A- 4154893 AU-B- 635562 AU-A- 6258190 EP-A- 0418828 WO-A- 9108267 JP-A- 4073158 US-A- 5262802	02-09-93 25-03-93 13-06-91 27-03-91 13-06-91 09-03-92 16-11-93