



US 20060255704A1

(19) **United States**

(12) **Patent Application Publication**
Grobleben et al.

(10) **Pub. No.: US 2006/0255704 A1**

(43) **Pub. Date: Nov. 16, 2006**

(54) **SHELF BASE FOR A REFRIGERATOR**

(30) **Foreign Application Priority Data**

(75) Inventors: **Ralf Grobleben**, Bretten (DE); **Thomas Knoller**, Karlsruhe (DE); **Petra Wustling**, Karlsruhe (DE)

Aug. 29, 2003 (DE)..... 103 39 932.1

Publication Classification

Correspondence Address:
BSH HOME APPLIANCES CORPORATION
INTELLECTUAL PROPERTY DEPARTMENT
100 BOSCH BOULEVARD
NEW BERN, NC 28562 (US)

(51) **Int. Cl.**
A47B 96/04 (2006.01)
(52) **U.S. Cl.** **312/408**

(73) Assignee: **BSH Bosch und Siemens Hausgerate GmbH**, Munich (DE)

(57) **ABSTRACT**

(21) Appl. No.: **10/567,321**

A shelf base for a refrigerator, the base including a plate and an upper and a lower retaining rail, running along an upper and a lower side of the plate. The upper and lower retaining rails mounting a support to house chilled goods. The retaining rails, connected in a unit, can be shifted along the transverse direction of the plate.

(22) PCT Filed: **Aug. 30, 2004**

(86) PCT No.: **PCT/EP04/09648**

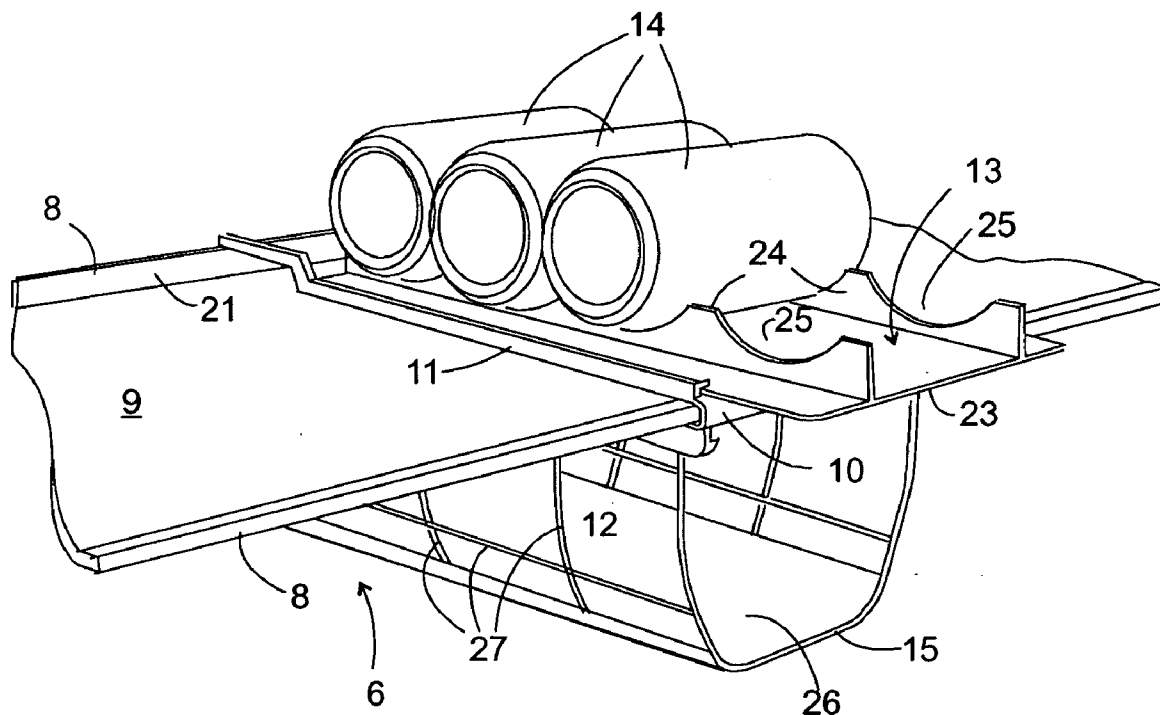

Fig. 1

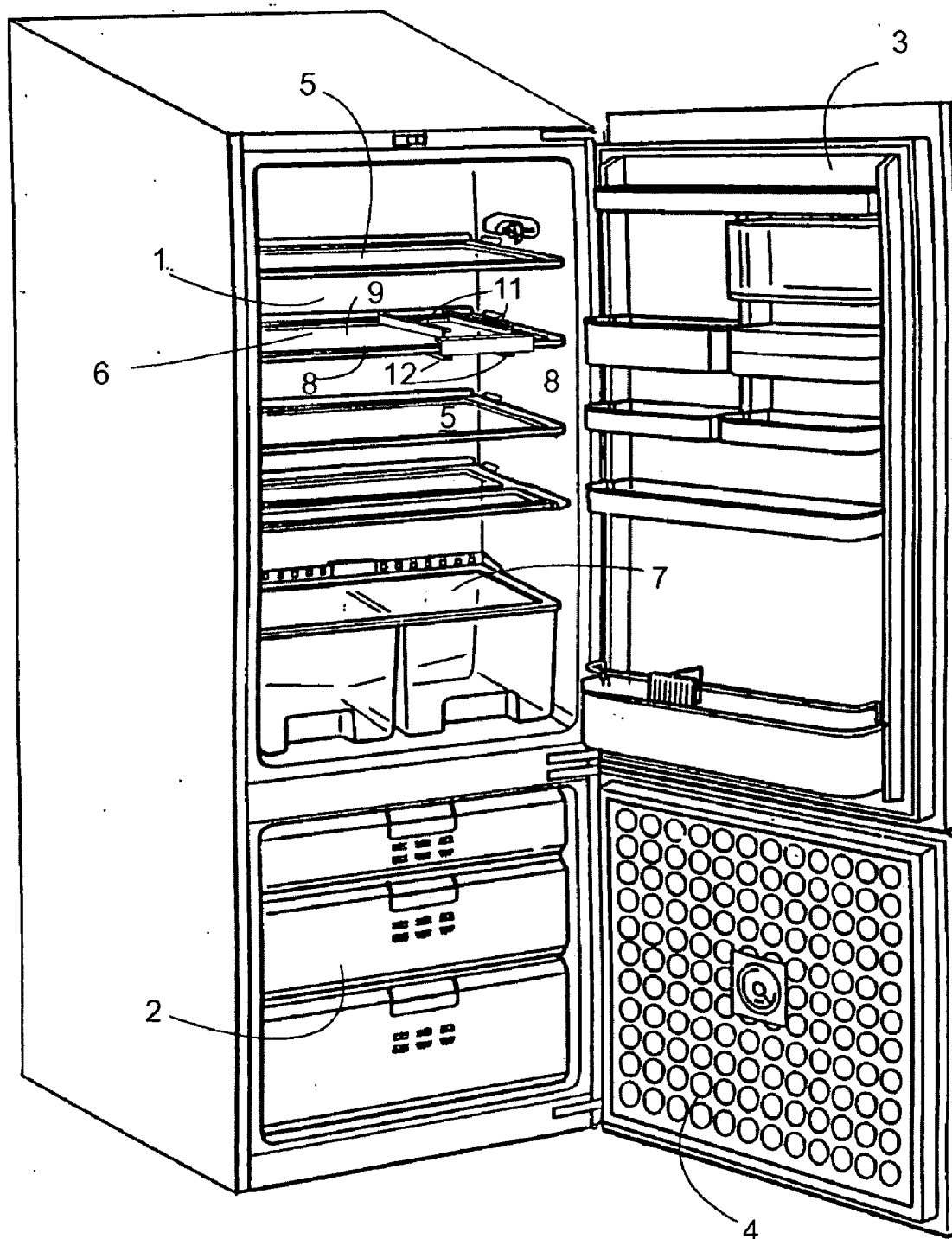

Fig. 2

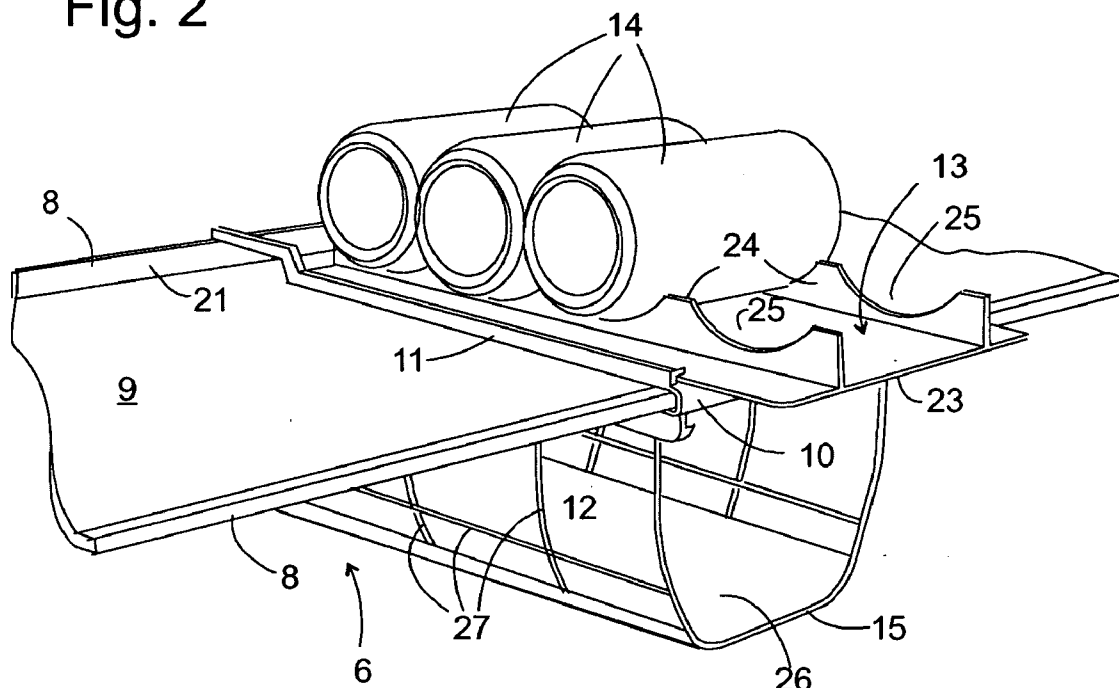

Fig. 3

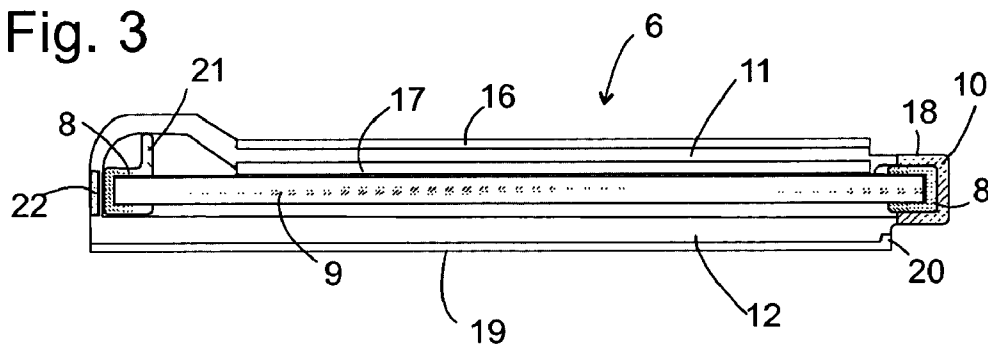

Fig. 4

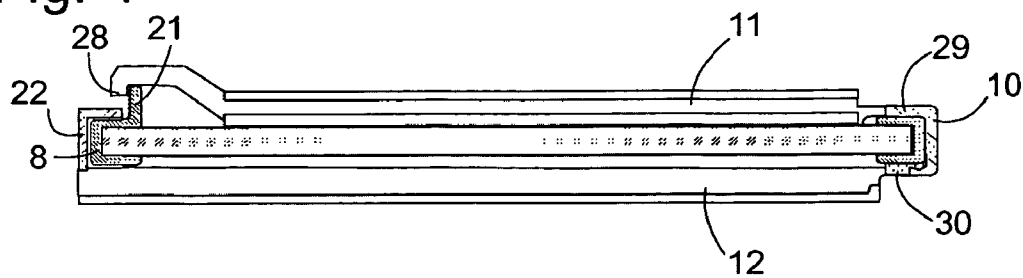

Fig. 5

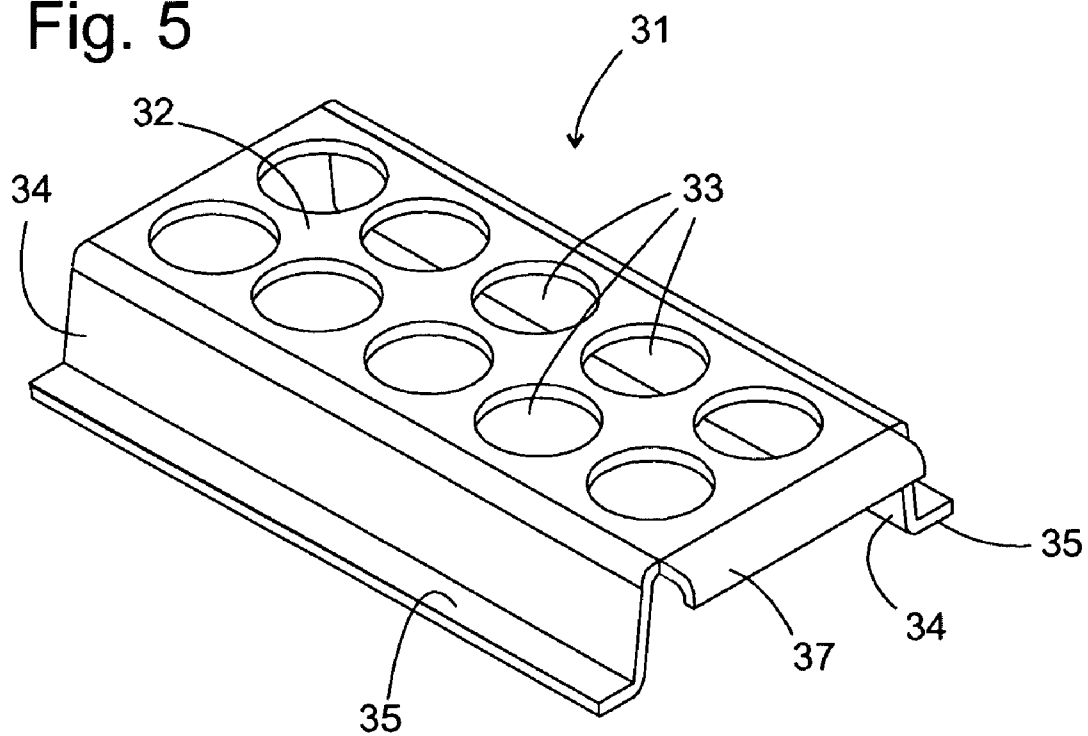
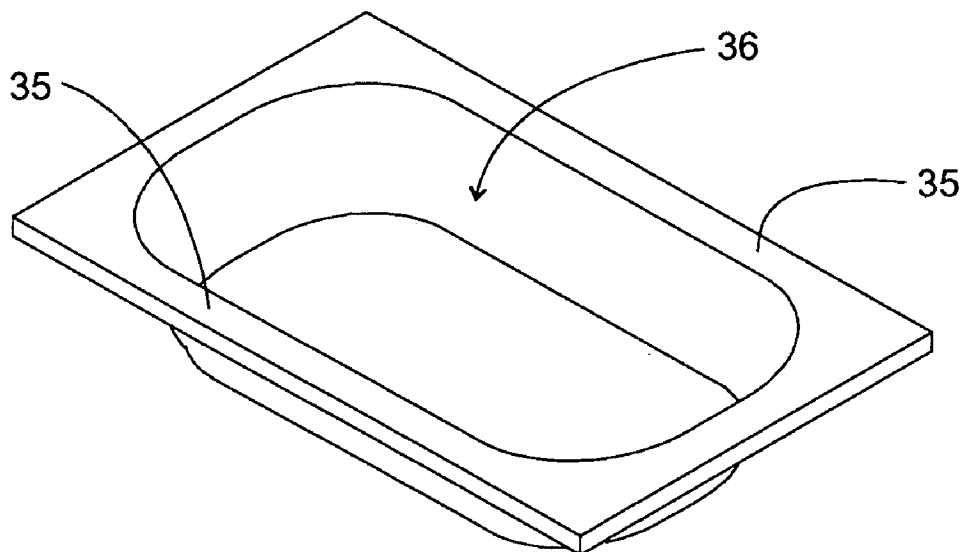

Fig. 6



SHELF BASE FOR A REFRIGERATOR

[0001] The invention relates to a shelf base for use in a cooling device, especially in a refrigerator. These shelf bases are generally loaded with items to be cooled, whose height cannot be greater than the height of a compartment which delimits the shelf base at the bottom. If the height of the items is smaller, it is difficult to efficiently utilise the cooling compartment since not all the items to be stored in a refrigerator are suitable for stacking and even if stacking is possible, stacking takes time and makes it difficult to access items lying at the bottom of the stack.

[0002] In order to improve the possibilities for utilising space in a refrigerator, a shelf base has been proposed having retaining rails located on its underside to which a container suspended from the shelf base can be attached. This type of container then makes it possible to efficiently use the volume of a compartment underneath the shelf base even when items placed on the bottom of this compartment are significantly smaller than the height of the compartment.

[0003] It is the object of the invention to further improve the diversity of the possibilities for utilising the space of such a shelf base.

[0004] The object is solved by a shelf base having the features of claim 1.

[0005] The retaining rails extending on the upper side of the plate of the shelf base allow a special support for chilled goods to be attached to the upper side of the shelf base.

[0006] Each upper retaining rail is preferably connected at at least one of its ends, preferably the front end, to one end of one of the lower retaining rails. This connection is preferably made by means of a clip spanning the front edge of the plate which is displaceable along the front edge and thus also allows the retaining rails to be displaced along the plate. Thus, the retaining rails can each be displaced to the location of the shelf base at which they are utilised most efficiently.

[0007] It is appropriate if a single clip interconnects all upper and lower retaining rails. Thus, even during a displacement the distance between the upper retaining rails and between the lower retaining rails is kept constant and the supports whose width is matched to this spacing of the rails, are held reliably independently of any displacement of the rails.

[0008] The rear ends of respectively one upper and one lower retaining rail can also be connected by a clip which spans the rear edge of the plate and is displaceable along the rear edge. If both ends of the rails are each connected by such clips, these form a unit extending around the shelf base which can only be unintentionally released from the plate in the event of break in the rails. Nevertheless, these rails can be released non-destructively from the plate by removing the shelf base from the cooling device and removing the interconnected rails in the lateral direction.

[0009] The lower and/or the upper retaining rails are preferably open at their front ends to allow a support to be attached by inserting into the rails from the front without the need to dismantle the rails. In order to avoid a support being unintentionally released from the retaining rails during withdrawal, an upwardly directed projection is formed at the front end of the bearing surface of at least one rail which

supports the support, which projection can only be overcome by a support held in the rails if it is simultaneously pulled and raised, which effectively prevents any unintentional withdrawal of the support from the retaining rails.

[0010] The lower retaining rails are especially useful for attaching a dish or a bottle holder therein. The upper retaining rails can be used to attach a support for drink cans. This type of support can be simply constructed from a base plate parallel to the plate of the shelf base and is secured by ribs provided with indentations, which project from the base plate and in which a drinks can is secured against rolling away in the horizontal position.

[0011] A support which can be attached in the upper or lower retaining rails as desired is an egg holder.

[0012] This type of egg holder can be simply formed by a perforated base plate whose holes are provided to hold eggs, side flanks developed from the base plate and clips which project from the side flanks and engage in the retaining rails. Assuming that the side flanks are of sufficient height, such an egg holder can be inserted in the upper or the lower retaining rails according to the needs of the user.

[0013] Further features and advantages of the invention are obtained from the following description of exemplary embodiments with reference to the appended figures. In the figures:

[0014] **FIG. 1** is a perspective view of a refrigerator fitted with a shelf base according to the invention;

[0015] **FIG. 2** is a partial view of a shelf base with retaining rails mounted thereon and supports held in the retaining rails;

[0016] **FIG. 3** is a section through the shelf base from **FIG. 2** omitting the supports;

[0017] **FIG. 4** is a section through the shelf base according to a second embodiment of the invention;

[0018] **FIG. 5** shows an egg holder mounted on the retaining rails; and

[0019] **FIG. 6** shows a shell for mounting on the lower retaining rails of the shelf base.

[0020] **FIG. 1** is a perspective view of a combination refrigerator with cooling zone 1 and freezing zone 2 with doors 3, 4 open. The cooling zone 1 is divided into a plurality of compartments by shelf bases 5, 6, 7. In the present case, the shelf bases 5, 6, 7 are each formed by a glass plate 9 enclosed in a plastic frame 8 and supported by supporting ribs arranged on the side walls of the cooling zone 1. In the case of the shelf base 6, the front area of the frame 8 is embraced by a U-profile 10 from the two ends of which respectively one retaining rail 11, 12 extends above and below the glass plate 9 towards the rear wall of the cooling zone 1, the retaining rails 11, 12 being arranged one above the other separated by the glass plate 9.

[0021] The shelf base 6 is shown in an enlarged partial view in **FIG. 2** and in cross-section along a vertical plane running between the upper retaining rails 11 in **FIG. 3**. In the case in **FIG. 2**, the upper retaining rails 11 are fitted with a partially withdrawn holder 13 for drinks cans 14, the lower rails 12 are fitted with a bottle holder 15 to receive a bottle (not shown) horizontally.

[0022] As can be seen in FIG. 3, the front U-profile 10 goes over in one piece into the two upper and lower retaining rails 11, 12. In the cross-section transverse to the plane in FIG. 3 the upper retaining rails 11 have a U-shaped cross-section with horizontal legs 16, 17 of which the lower leg 17 forms the bearing surface for the can holder 13. The bearing surface of the leg 17 is slightly deeper than the upper side 18 of the U profile 10 so that the can holder 13 cannot be withdrawn from the retaining rails 11 from the front (to the right in the figure) without previously lifting over the upper side 18 of the U-profile 10.

[0023] The lower retaining rails 12 each have an L-shaped cross-section transverse to the plane of FIG. 3 and a bearing surface for the bottle holder 15 on the upper side of a horizontal leg 19 of the L is terminated at its front end adjacent to the U profile 10 by an upward-projecting projection 20 which, in the same way as the projecting upper side 18, is used to prevent any unintentional slippage of the support from the rails.

[0024] The part of the frame 8 facing the rear wall of the cooling zone, on the left in FIG. 3, is provided with an upwardly projecting web 21 to prevent or at least make difficult any unintentional contact between chilled goods placed on the shelf base 6 and the rear wall. The upper retaining rails 11 extend in an arc over the web 21 and between the rear edge of the frame 8 and the rear wall and finally merge with the lower retaining rails 12. A cross-member 22 which extends parallel to the rear edge of the frame 8 joins the rear ends of all four retaining rails 11, 12 one to the other. The four rails 11, 12 thus form a rigid unit displaceable in the transverse direction of the shelf base. In order to dismantle these when not in use, the shelf base can be removed from the refrigerator and the unit can be moved downwards in the lateral direction from the shelf base.

[0025] The can holder 13 from FIG. 2 is a one-piece plastic injection moulding comprising a base plate 23 whose lateral edges each lie on the lower legs 17 of the upper retaining rails 11 and two ribs 24 parallel to the retaining rails, which project vertically from the base plate 23, which are provided with a plurality of circular-segment-shaped indentations 25 along their upper edge. The radius of the indentations 25 is adapted to the radius of commercially available drinks cans so that these are held securely in the horizontal position on the ribs 24. The extractability of the can holder 13 from the retaining rails 11 makes it easy to access a rear can 14 without first moving the cans located in front, as would be necessary with the conventional storage of the cans on one of the shelf bases 5.

[0026] The bottle holder 15 is an elongated basket open at one end, made of plastic or powder-coated metal, comprising a closed base plate 26 and wires 27 which start from this base plate 26, forming the side flanks of the bottle carrier, these wires being connected at their upper ends by two horizontal webs each engaging in one of the lower retaining rails 12. The wires 27 can have a certain flexibility so that so that by pressing together the flanks of the bottle carrier 15, it is possible to release the webs from the retaining rails 12 and remove the bottle carrier 15 without pulling this forward from the retaining rails 12.

[0027] FIG. 4 shows a section similar to FIG. 3 through a second embodiment of the shelf base. Here the upper and lower retaining rails 11 and 12 are not connected in the area

of their rear ends but the rear ends of the lower supporting rail 12 are suspended at the rear edge of the frame 8 using a cross-member 22 which has an L-shaped cross-section here and the rear ends of the upper retaining rails 11 each have a hook 28 which engages behind the cross-piece 21 of the frame 8. The U-profile 10 is constructed in two parts, comprising an upper section 29 connected to the upper retaining rails 11 and lower section 30 linking the lower supporting rails 12 which are engaged with one another. By lifting the hook 28 over the web 21 and pulling the upper retaining rails 11 forward, the locating connection between the sections 29, 30 can be released, the front end of the lower retaining rails 12 with the section 30 comes free and the lower retaining rails 12 can be released by pushing them so far backwards that contact between the horizontal leg of the cross-member 22 and the frame 8 is lost and the retaining rails 12 can be removed downwards. This operation is possible without removing the shelf base 6 from the refrigerator.

[0028] FIG. 5 shows an egg holder 31 as another example of a support which can be used with the shelf base 6. Formed in a horizontal plate 32 are circular openings 33 whose diameter is slightly smaller than that of an egg and which can each hold an egg. Adjoining two edges of the plate 32 are vertical flanks 34 and adjoining these in turn are horizontal webs 35 which are provided for engaging in retaining rails. A grip section 37 bent towards the plate 32 is formed on a third edge. In the orientation shown the egg holder 31 can be mounted in the upper retaining rails 11; if the vertical flanks 34 are sufficiently high however, it is also possible to mount the holder 31 loaded with eggs, with the webs 35 turned upwards, in the lower retaining rails 12.

[0029] The lower retaining rails 12 can also be fitted with a shell 36 as shown in FIG. 6, with horizontal webs 35 for engaging in the retaining rails 12 being formed at its edges.

1-14. (canceled)

15. A shelf base for a refrigerator;

comprising a plate;

lower retaining rails extending along a lower side of the plate for attachment for a support for holding chilled goods; and

upper retaining rails for another support extend along the upper side of the plate.

16. The shelf base according to claim 15, including said upper and lower retaining rails are arranged one above the other.

17. The shelf base according to claim 15, including said upper and lower retaining rails are arranged in the direction of the holder of the shelf base in retaining means used for the refrigerator.

18. The shelf base according to claim 15, including said upper retaining rails are connected at least at one of their ends to respectively one end of one of said lower retaining rails.

19. The shelf base according to claim 15, including front ends of respectively one of said upper and one of said lower retaining rails are connected by a guide profile which spans the front edge of said plate and is displaceable along said front edge.

20. The shelf base according to claim 18, including a plurality of clips interconnect all said upper and lower retaining rails.

21. (canceled)

22. The shelf base according to claim 18, including at least one of said lower and said upper retaining rails are open at their rear ends.

23. The shelf base according to claim 29 including an upwardly projecting projection formed at the front end of a bearing surface of at least one of said lower rails.

24. The shelf base according to claim 18, including one of a shell or a bottle holder is mounted in said lower retaining rails as a support.

25. The shelf base to claim 18, including a support for drinks cans mounted in said upper retaining rails.

26. The shelf base according to claim 25, including said support for drinks cans includes a base plate substantially

parallel to said plate and includes ribs provided with indentations projecting from said base plate.

27. The shelf base according to claim 15, including an egg holder mounted in one of said upper or lower retaining rails.

28. The shelf base according to claim 27, including said egg holder includes a perforated base plate, a pair of side flanks bent away from said perforated base plate and webs which project from said side flanks and engage in said retaining rails.

29. The shelf base according to claim 18, including rear ends of respectively one of said upper and one of said lower retaining rails span the rear edge of said plate and are displaceably connected along said rear edge.

* * * * *