

June 19, 1923.

1,459,531

E. J. HANSON
COMBINATION TOOL

Filed Jan. 18, 1922

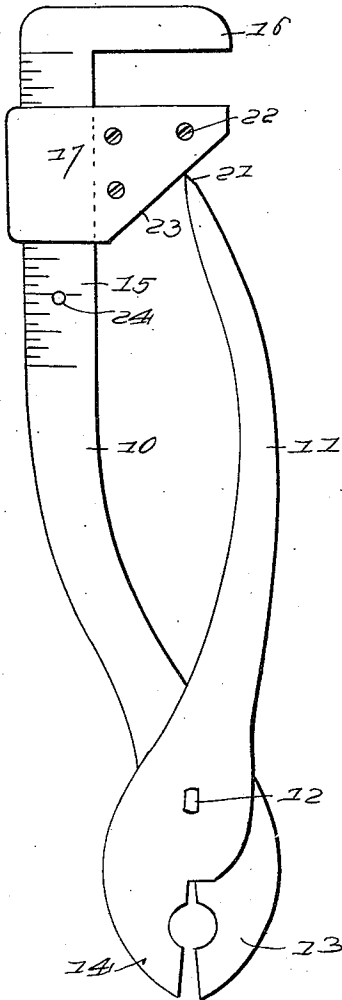

Fig. 1.

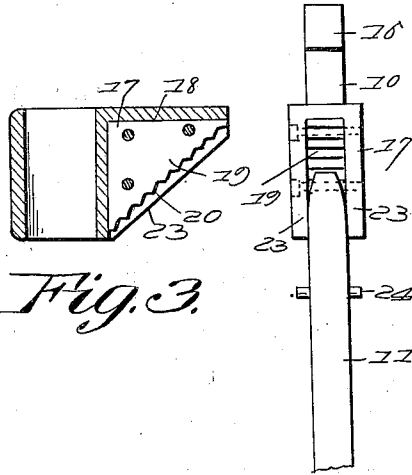

Fig. 2.

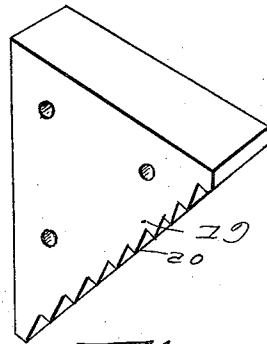

Fig. 3.

Inventor
Emil J. Hanson,

By *Edmund Albert*
Attorney

UNITED STATES PATENT OFFICE.

EMIL J. HANSON, OF VIROQUA, WISCONSIN.

COMBINATION TOOL.

Application filed January 18, 1922. Serial No. 530,048.

To all whom it may concern:

Be it known that I, EMIL J. HANSON, a citizen of the United States of America, residing at Viroqua, in the county of Vernon and State of Wisconsin, have invented new and useful Improvements in Combination Tools, of which the following is a specification.

The object of the invention is to provide a simple and efficient combination tool having special reference to a wrench and means for effectively adjusting and locking the movable jaw thereof to adapt it to the size of the object to which it may be fitted; and to this end the invention consists in a construction and combination of parts of which a preferred embodiment is shown in the accompanying drawings, wherein:—

Figure 1 is a side view of a tool embodying the invention,

Fig. 2 is an edge view of a portion of the same,

Fig. 3 is a sectional view taken longitudinally of the movable jaw, and

Fig. 4 is a detail view in perspective of the ratchet block with which the movable jaw is fitted.

The tool is essentially of the pliers form having shanks 10 and 11 pivotally connected at 12 to form an adjustable joint and having plier jaws 13 and 14 capable of use in the ordinary way and as wire cutters or the like, one of said shanks being extended to form a wrench stem 15, preferably graduated as shown and terminating in a rigid power wrench jaw 16, while slidingly fitted on said stem is a movable inner jaw 17 for cooperation with the rigid jaw as in the ordinary construction of wrenches.

Carried by the movable wrench jaw in a cavity 18 formed in the front face thereof is a ratchet block 19 having a ratchet face 20 which is disposed at an inclination to the path of movement of the movable jaw on the shank or stem and in the path of transverse movement of the free end of the shank 11 which terminates in a reduced tooth 21 for engagement with the teeth of the ratchet as a means of locking the movable wrench jaw in its adjusted positions. The ratchet face of the block 19, which is removably seated in the cavity 18 and secured replaceably by transverse screws 22 or the equivalents thereof, is inset from the plane of the edges of the jaw 17 as clearly indicated in Fig. 3, so that said edges constitute side guides 23 to pre-

vent lateral displacement of the toothed extremity of the shank 11 when in engagement with the ratchet teeth 20, and hence release of the movable wrench jaw when the wrench feature of the tooth is in use. Obviously when the wrench is in use the operator grasps the shanks 10 and 11 mutually with a tendency to press them toward each other so that the terminal tooth 21 of the shank 11 is firmly held in engaging relation with the ratchet teeth 20, whereas when the plier jaws are being used the wrench jaws constitute a convenient knob at the end of the shank 10 to prevent the hand of the operator from slipping longitudinally on the shank 10 while the shank 11 is being manipulated to open and close the plier jaws.

Moreover in the event that it is desired to engage an object by means of the plier jaws without placing undue pressure thereon, and hence to prevent the forcing of the shanks toward each other when a more or less fragile object is arranged between the plier jaws, the movable wrench jaw with its ratchet may be utilized as a means of limiting the closing movement of the plier jaws by adjusting it to a position to limit the closing movement of the shanks.

In other words while the plier shank 11 serves as a conveniently available means of locking the movable wrench jaw in its adjusted positions, the movable wrench jaw likewise furnishes a convenient means of limiting the closing movement of the shanks and hence the closing movement of the plier jaws.

Having described the invention, what is claimed as new and useful is:—

1. A combination tool having shanks pivotally connected for relative swinging movement and provided adjacent to their pivotal points with complementary plier jaws, one of said shanks being provided at the opposite end with a rigid wrench jaw and the other with a terminal tooth, and a sliding wrench jaw mounted upon the first-named shank and provided with an obliquely disposed ratchet face for engagement by the terminal tooth of the second-named shank as a means of respectively limiting the opening movement of the wrench jaws and the closing movement of the plier jaws.

2. A tool having pivotally connected shanks provided adjacent to their pivotal ends with complementary plier jaws and at their opposite ends respectively with a rigid

wrench jaw and a tooth, and a movable wrench jaw mounted upon the shank which carries the rigid jaw and provided with an obliquely disposed ratchet face in the path
 5 of movement of the tooth on the extremity of the other shank for engaging the tooth.

3. A tool having pivotally connected shanks provided adjacent to their pivotal ends with complementary plier jaws and at
 10 their opposite ends respectively with a rigid wrench jaw and a tooth, and a movable wrench jaw mounted upon the shank which carries the rigid jaw and provided with an obliquely disposed ratchet face in the path
 15 of movement of the tooth on the extremity of the other shank for engaging the tooth, the movable jaw being provided with a cavity in which is removably fitted a block carrying said ratchet face.

4. A tool having pivotally connected 20 shanks provided adjacent to their pivotal ends with complementary plier jaws and at their opposite ends respectively with a rigid wrench jaw and a tooth, and a movable wrench jaw mounted upon the shank which 25 carries the rigid jaw and provided with an obliquely disposed ratchet face in the path of movement of the tooth on the extremity of the other shank for engaging the tooth, the movable jaw being provided with a cavity 30 in which is removably fitted a block carrying said ratchet face, and the walls of said cavity being extended beyond the plane of the ratchet face to form guides to limit the lateral movement of the shank-carried tooth. 35

In testimony whereof I affix my signature.

EMIL J. HANSON.