

(19) World Intellectual Property Organization
International Bureau



(43) International Publication Date
2 April 2009 (02.04.2009)

PCT

(10) International Publication Number
WO 2009/042022 A1

- (51) International Patent Classification:
A01J 5/06 (2006.01)
 - (21) International Application Number:
PCT/US2008/010095
 - (22) International Filing Date: 26 August 2008 (26.08.2008)
 - (25) Filing Language: English
 - (26) Publication Language: English
 - (30) Priority Data:
11/904,607 27 September 2007 (27.09.2007) US
 - (71) Applicant: GEA WESTFALIASURGE, INC. [US/US];
1880 Country Farm Drive, Naperville, IL 60563 (US).
 - (72) Inventor; and
 - (75) Inventor/Applicant (for US only): SELLNER, Duane, F.
[US/US]; 64 Forest Oak Ct., Winona, MN 55987 (US).
 - (74) Agent: SMITH, Jeffrey, W.; Smith Law Office, 8000 Ex-
celsior Drive, Suite 301, Madison, WI 53717 (US).
 - (81) Designated States (unless otherwise indicated, for every
kind of national protection available): AE, AG, AL, AM,
AO, AT, AU, AZ, BA, BB, BG, BH, BR, BW, BY, BZ, CA,
CH, CN, CO, CR, CU, CZ, DE, DK, DM, DO, DZ, EC, EE,
EG, ES, FI, GB, GD, GE, GH, GM, GT, HN, HR, HU, ID,
IL, IN, IS, JP, KE, KG, KM, KN, KP, KR, KZ, LA, LC, LK,
LR, LS, LT, LU, LY, MA, MD, ME, MG, MK, MN, MW,
MX, MY, MZ, NA, NG, NI, NO, NZ, OM, PG, PH, PL, PT,
RO, RS, RU, SC, SD, SE, SG, SK, SL, SM, ST, SV, SY, TJ,
TM, TN, TR, TT, TZ, UA, UG, US, UZ, VC, VN, ZA, ZM,
ZW.
 - (84) Designated States (unless otherwise indicated, for every
kind of regional protection available): ARIPO (BW, GH,
GM, KE, LS, MW, MZ, NA, SD, SL, SZ, TZ, UG, ZM,
ZW), Eurasian (AM, AZ, BY, KG, KZ, MD, RU, TJ, TM),
European (AT, BE, BG, CH, CY, CZ, DE, DK, EE, ES, FI,
FR, GB, GR, HR, HU, IE, IS, IT, LT, LU, LV, MC, MT, NL,
NO, PL, PT, RO, SE, SI, SK, TR), OAPI (BF, BJ, CF, CG,
CI, CM, GA, GN, GQ, GW, ML, MR, NE, SN, TD, TG).
- Published:**
— with international search report

WO 2009/042022 A1

(54) Title: TEAT CUP LINER

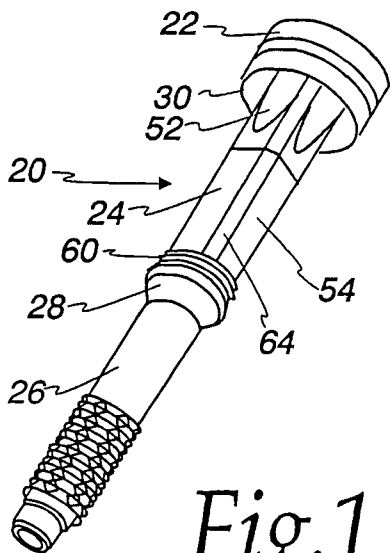

Fig. 1

(57) Abstract: A milking machine teat cup liner having a dome and a barrel, and the barrel has an upper transition portion and a lower square portion. The transition section mates with the round cross-section of the dome and the square cross-section of the lower square portion to provide superior vacuum seal with less irritation and damage to teat tissue.

TEAT CUP LINER**FIELD AND BACKGROUND OF THE INVENTION**

[0001] This invention relates generally to liners for milking machine teat cups, and more particularly to improved teat cup liners that provide a superior seal against a
5 teat upper portion and a controlled collapse around a teat lower portion to reduce tissue irritation and damage while enhancing the milking process.

[0000] Dairy animals, and particularly cows, are milked using automated milking machines. The milking machines include a milking unit including four teat cups, tubes downstream from the teat cups, a claw that acts as a manifold connected to the
10 tubes for receiving milk, a pulsator, and pulsation tubes. The milking machines connect downstream with equipment for collecting milk.

[0002] The interface between milking machine and animal is a flexible liner inside a teat cup. A teat fits inside the liner during milking. An annular space between the liner and the teat cup is called a pulsation chamber. Vacuum from a vacuum pump is
15 controlled by the pulsator to provide the pulsation of vacuum and pressure necessary to withdraw milk from the teats. A continuous vacuum is applied inside the liner to withdraw milk and keeps the milking unit attached to a cow. The continuous vacuum causes congestion of blood and other fluids in teat tissue. To relieve this congestion, atmospheric air is allowed into the pulsation chamber by the pulsator so

that the flexible liner collapses onto the teat to relieve the congestion in the teat tissue. This pulsating action efficiently milks dairy animals.

[0003] The liner design is critical to obtaining efficient and complete milking while simultaneously providing maximum comfort and minimal irritation to the animal
5 teats. Liners include at least two key components. First, is an upper dome portion and second is a lower barrel portion. Some liners include short tubes extending downstream from the liner barrel to connect to the milking claw. Other liners are designed to be connected to a separate short milk tube.

[0004] The upper dome portion includes an upper surface defining an opening
10 through which a teat is inserted. The dome also includes an outer cylindrical wall with a lip to engage a teat cup. The dome defines an inner volume in which the vacuum acts to hold the milking unit on the animals. The shape and volume of liner domes have been studied for applying optimum vacuum and pressure to teats. (See U.S. Patent 5,752,462.)

[0005] Liner barrels too have been the subject of considerable study. A basic liner
15 barrel is cylindrical and essentially round in cross-section. When atmospheric pressure is applied in the pulsation chamber against the outer surface of the liner barrel, it collapses by flattening into a tight oval shape, and thereby applies pressure from two sides against a teat. Since teats are essentially round in cross-section, the
20 application of pressure from two sides can cause undue stress, irritation, and excessive pressure on teat tissue.

[0006] In U.S. Patent 3,967,587, the above problem with round barrels was
addressed with a liner barrel having a square cross-section so that pressure was
applied from four sides instead of two. The total pressure applied to a liner is the
25 same regardless of whether the liner barrel is round or square in cross-section, so

applying that pressure from four sides instead of two reduced the pressure and irritation on the teat by about one half.

[0007] One downside to a square-barreled liner is that during the vacuum phase, the teat tissue tends to expand into the corners of the square barrel and cause irritation of teat tissue. Further, the milking machine teat cups are held onto a teat by the vacuum in the liner. Therefore, a seal between teat and liner is necessary so that the milking machine does not fall off the cow during milking. Barrel liners with square cross-sections tend not to form as secure a seal with teats, and premature release can occur.

[0008] Thus, there is a need for a milking machine teat cup liner that will form a secure seal with a dairy animal teat, while simultaneously applying relatively uniform and gentle pressure to a teat for milking.

SUMMARY OF THE INVENTION

[0009] The present invention overcomes the excessive pressure applied by a liner barrel with a circular cross-section and the tissue irritation and vacuum loss that can result from a liner barrel with a square cross-section. The present invention utilizes a liner barrel with a round cross-section in its upper portion and a square cross-section in its lower portion to obtain a uniform seal with minimal irritation in the upper portion of a teat and with reduced pressure applied to the lower portion of a teat.

[0010] A liner in accordance with the present invention includes an upper dome portion having a top surface defining a teat opening, and a barrel joined to or formed integrally with the dome. The barrel has an upper transition portion with a substantially round cross-section and a lower portion with a substantially square cross-section. The upper portion can be tapered so that it has a generally round cross-section and becomes progressively smaller in diameter from top to bottom.

[0011] The upper round cross-section portion of the liner barrel creates a transition from the round cross-section of the liner dome to the lower square cross-section of the barrel. The beginning of the transition can begin at a lower end of a rounded shoulder inside the liner dome. Alternatively, the upper extreme of the transition section may be measured from the top surface of the dome when a dome shoulder is not present or has an irregular shape, for example.

[0012] Preferably, the transition portion is from between about one-half inch to one and a half inches long, and extends downward from the liner dome shoulder. The transition portion can begin from about three-quarters of an inch to about one and one half inch from the top of the liner dome. Another alternative is to have a transition portion that is up to about thirty percent of the total length of the liner barrel.

BRIEF DESCRIPTION OF THE DRAWINGS

[0013] Fig. 1 is a perspective view of a teat cup liner in accordance with the present invention;

[0014] Fig. 2 is a partial cross-section of a teat cup liner in accordance with the present invention;

[0015] Fig. 3 is a side view of a teat cup liner in accordance with the present invention;

[0016] Fig. 4 is a cross-section of a teat cup liner in accordance with the present invention; and

[0017] Fig. 5 is a cross-sectional view of a liner barrel taken along line 5-5 in Fig. 3.

DETAILED DESCRIPTION OF THE PREFERRED EMBODIMENTS

[0018] In the following detailed description of the preferred embodiments, the same reference numeral will be used to identify the same item in each of the drawings.

Illustrated generally in Figs. 1 through 4 is a teat cup liner 20 in accordance with the present invention, having an upper dome 22, a barrel 24, and an optional short milk tube 26. Typically, liners 20 are made of rubber or silicone and are molded in a single piece.

5 [0019] Liners 20 are shaped and sized to fit within a teat cup of a milking machine (not illustrated). The teat cup and liner 20 cooperate to form an inflation that alternates applying pressure and vacuum from a vacuum pump (not illustrated) to massage a dairy animal's teat to withdraw milk.

[0020] The liner 20 dome 22 includes an annular wall 30, an upper surface 32, a teat opening 34 in the upper surface 32, and a shoulder 36. The annular wall 30 is
10 connected to an upper portion 40 of the shoulder 36, but is spaced apart from the rest of the shoulder 36 and the barrel 24 to define a recess 42 into which the top of a teat cup fits to secure the liner 20 to the teat cup. The upper surface 32 of the dome 22 is essentially flat, and the teat opening 34 is essentially round and sized to fit closely to
15 a dairy animal teat inserted therethrough.

[0021] The dome shoulder 36 is spaced from the upper surface 32 to define a chamber 46 inside of the dome 22. The shoulder 36 radius and spacing from the upper surface 32 can be selected to create a desired chamber 46 volume. In some liners, the shoulder 36 may not be well-defined or have a consistent radius.
20 Nonetheless, in a preferred embodiment of the present invention, the shoulder 36 has a radius of about .351 inches and extends into the liner 20 dome 22 about .75 inches.

[0022] Extending downward from the shoulder 36 is the barrel 24. The barrel 24 defines a bore 50 into which a dairy animal teat will fit. The barrel 24 of the present invention includes an upper transition portion 52 and a lower square portion 54. The
25 upper transition portion 52 changes in cross-sectional shape from the round dome 22

to the lower square portion 54. Preferably, the transition portion 52 tapers from a relatively large internal diameter to a relatively small diameter from top to bottom. The preferred upper diameter is between about .828 inches and about .930 inches, and the shape is generally conical and tapers by about three to about ten degrees with the most preferred being about five degrees per side downward and inward. The preferred lower internal diameter is about .828 inches. The total length of the upper transition portion 52 is about 1.25 inches to about 1.38 inches long.

[0023] Preferably, the upper transition portion 52 has a length that is measured downward from the dome 22 shoulder 36 and has a length in the range of about three-quarters of an inch to about one and one-half inches. More preferably, the transition portion 52 is about 1.387 inches long. Alternatively, regardless of the dome shoulder 36 size, the transition portion 52 can begin from about three-quarters of an inch to about one and one-half inch down from the upper surface 32 of the dome 22, and extend downward the length described above. The total length of the barrel 52 is between about 4.75 inches and 4.90 inches, and will increase (stretch) by about .919 inches plus or minus .060 inches when installed. The measurements are preferred only, and other measurements that accomplish the objectives herein are within the scope of the present invention. Indeed, measurements may vary depending on the animals being milked and the average teat size of the animals being milked.

[0024] The lower square portion 54 is desirable for reducing pressure on teat tissue and the corners 64 resist bending and remain relatively straight while the flat sides 66 collapse. The wall thickness of the barrel square portion 54 is about 0.100 inches, while the corner-to-corner dimensions X and Y (Fig. 5) are preferably .942 inches across one side and .828 inches across the other side. The larger dimension X

corresponds to corners with a .059 inch radius and the smaller dimension Y corresponds to a corner radius of about 0.197 inches. This differential causes the square barrel portion 54 to collapse in a roughly diamond shape for better control of the collapse and application of pressure to the teat.

5 [0025] The lengths of the transition portion 52 and the square portion 54, may be expressed in terms of ratios, as well. For example, the transition portion 52 may be about 20% to about 40% with the most preferred being about 30% of the total barrel 24 length. As used herein “upper” means the upstream end of the liner 20 and “lower” means the downstream end of the liner 20.

10 [0026] As indicated above, the liner 20 and teat combine to define an inner volume. The lower end of the inner volume of the liner 20 is defined by the inside rounded corner of the square barrel portions 54 adjacent to the short milk tube 26. The upper end of the volume is defined by the inner top of the dome 22.

[0027] The short milk tube 26 that extends down from the barrel 24 is optional and 15 short milk tubes of other shapes and sizes, could be used, including short milk tubes that are separate elements to be attached to the liner 20.

[0028] Between the barrel 24 and the short milk tube 26 is a thickened connector portion 28 that defines an annular recess 60 for engaging a hole in the bottom of a teat cup to maintain the liner 20 in a secure and extended position within the teat 20 cup.

[0029] The foregoing detailed description of the drawings is meant for clearness of understanding only, and no unnecessary limitations therefrom should be read into the following claims. In particular, the terms “round” and “square” are general terms intended to cover generally oval and rectangular shapes, respectively. These terms 25 may also include shapes with imperfect symmetry and unequal corner angles, for

example, because exact shapes formed with flexible materials are not possible.

CLAIMS

1. A liner for a milking machine teat cup, the liner comprising:
a dome having an upper surface and a substantially round cross-section;
5 a barrel joined to the dome, the barrel having an upper transition portion
that is substantially round in cross-section and a lower portion that
is substantially square in cross-section.
2. The liner of claim 1, wherein the upper transition portion has a length of
between about three-quarters of an inch to about one and one-half inches.
- 10 3. The liner of claim 1, wherein the dome comprises:
a shoulder; and
the upper transition portion is joined to a lower end of the shoulder.
4. The liner of claim 1, wherein a top of the transition portion is from about
three-quarters of an inch to about one and one-half inch from the upper surface of
15 the dome.
5. The liner of claim 1, wherein the top transition portion is generally conical in
shape and tapers downward at an angle of about three degrees to about ten degrees.

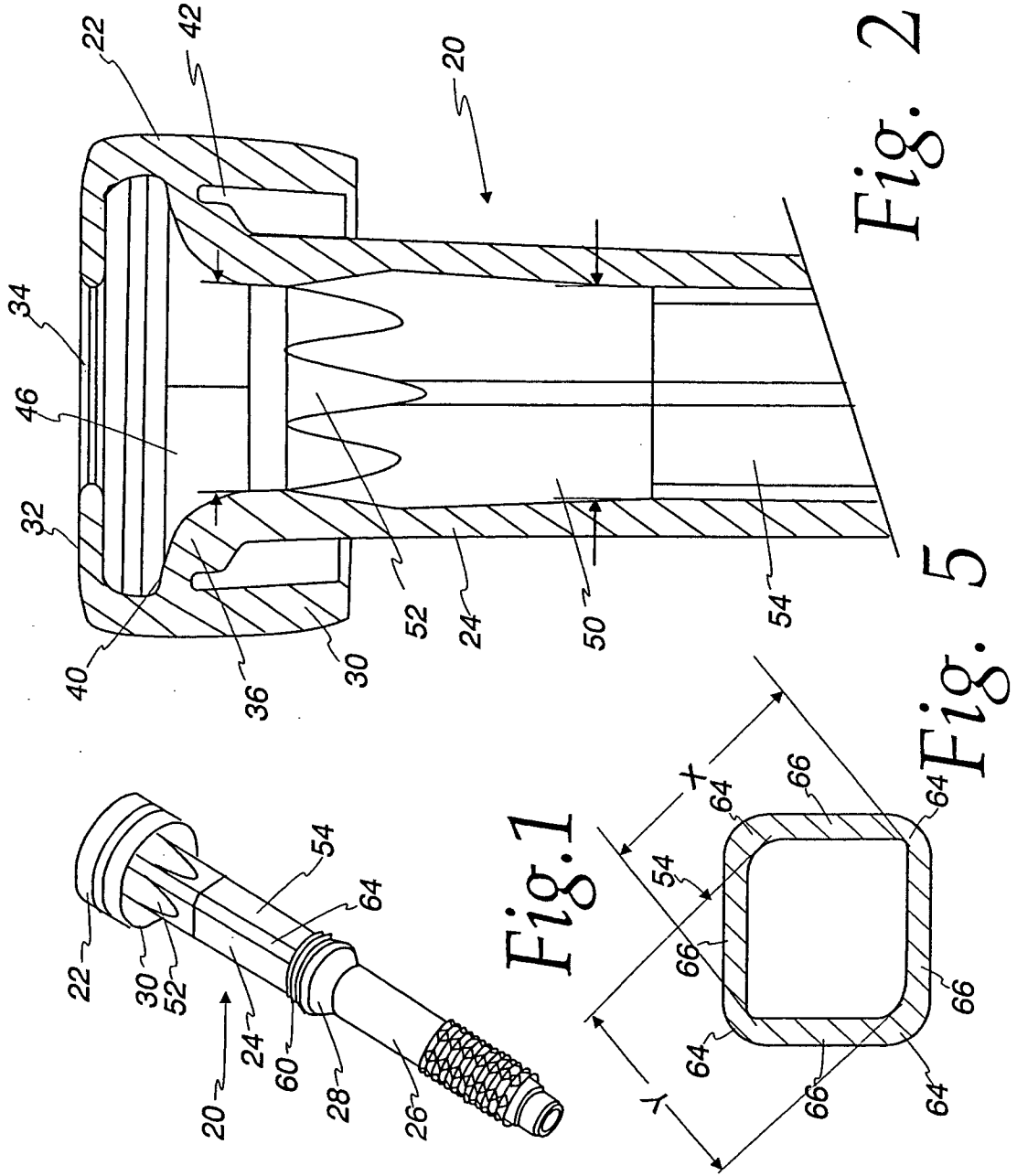

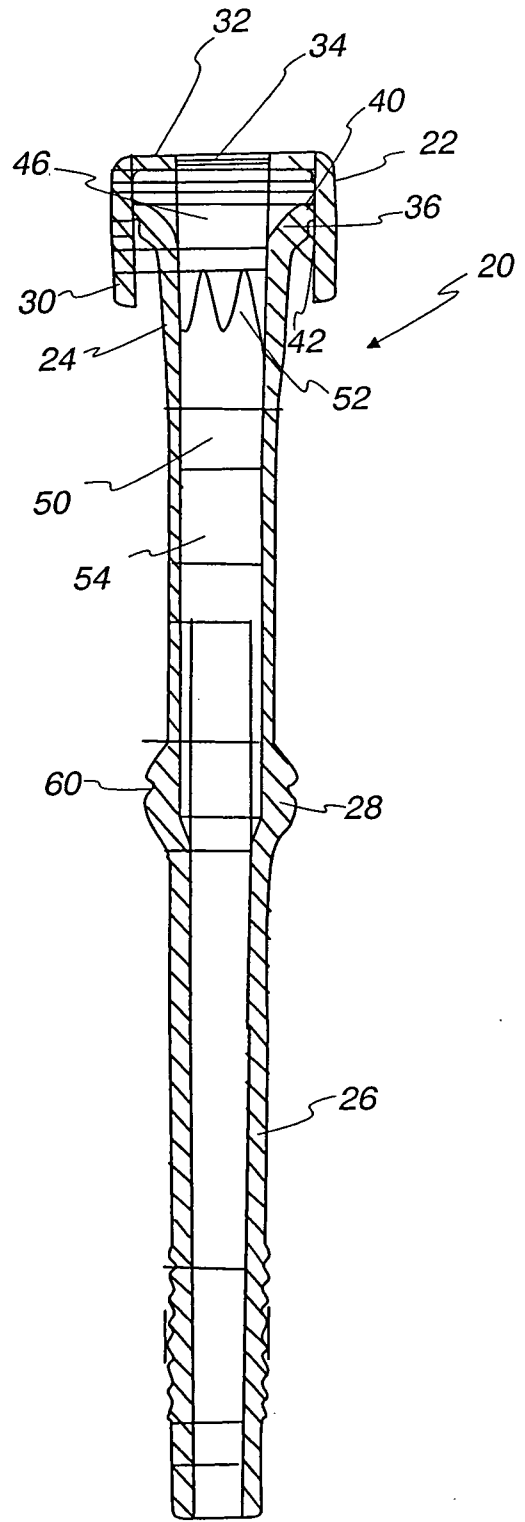
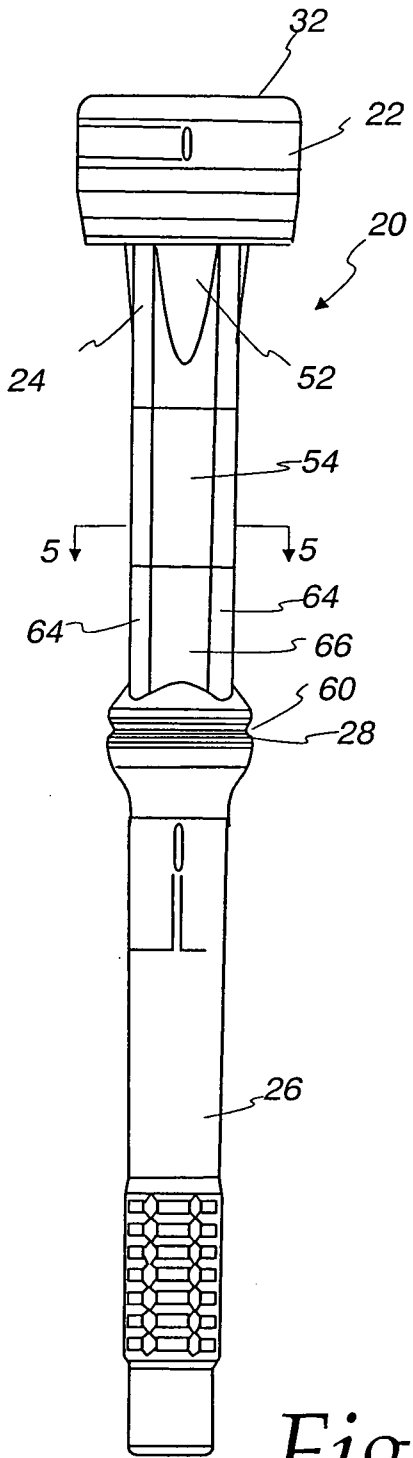

INTERNATIONAL SEARCH REPORT

International application No.

PCT/US2008/010095

A. CLASSIFICATION OF SUBJECT MATTER

IPC(8) - A01J 5/06 (2008.04)

USPC - 119/14.47

According to International Patent Classification (IPC) or to both national classification and IPC

B. FIELDS SEARCHED

Minimum documentation searched (classification system followed by classification symbols)

IPC(8) - A01J 5/06 (2008.04)

USPC - 119/14.47

Documentation searched other than minimum documentation to the extent that such documents are included in the fields searched

Electronic data base consulted during the international search (name of data base and, where practicable, search terms used)

MicroPatent

C. DOCUMENTS CONSIDERED TO BE RELEVANT

Category*	Citation of document, with indication, where appropriate, of the relevant passages	Relevant to claim No.
Y	US 2006/0016399 A1 (TORGERSON) 26 January 2006 (26.01.2006) entire document	1-5
Y	US 5,752,462 A (PETERSSON) 19 May 1998 (19.05.1998) entire document	1-5

Further documents are listed in the continuation of Box C.

* Special categories of cited documents:

"A" document defining the general state of the art which is not considered to be of particular relevance

"E" earlier application or patent but published on or after the international filing date

"L" document which may throw doubts on priority claim(s) or which is cited to establish the publication date of another citation or other special reason (as specified)

"O" document referring to an oral disclosure, use, exhibition or other means

"P" document published prior to the international filing date but later than the priority date claimed

"T" later document published after the international filing date or priority date and not in conflict with the application but cited to understand the principle or theory underlying the invention

"X" document of particular relevance; the claimed invention cannot be considered novel or cannot be considered to involve an inventive step when the document is taken alone

"Y" document of particular relevance; the claimed invention cannot be considered to involve an inventive step when the document is combined with one or more other such documents, such combination being obvious to a person skilled in the art

"&" document member of the same patent family

Date of the actual completion of the international search

27 October 2008

Date of mailing of the international search report

06 NOV 2008

Name and mailing address of the ISA/US

Mail Stop PCT, Attn: ISA/US, Commissioner for Patents

P.O. Box 1450, Alexandria, Virginia 22313-1450

Facsimile No. 571-273-3201

Authorized officer:

Blaine R. Copenheaver

PCT Helpdesk: 571-272-4300
PCT OSP: 571-272-7774

Blaine R. Copenheaver