

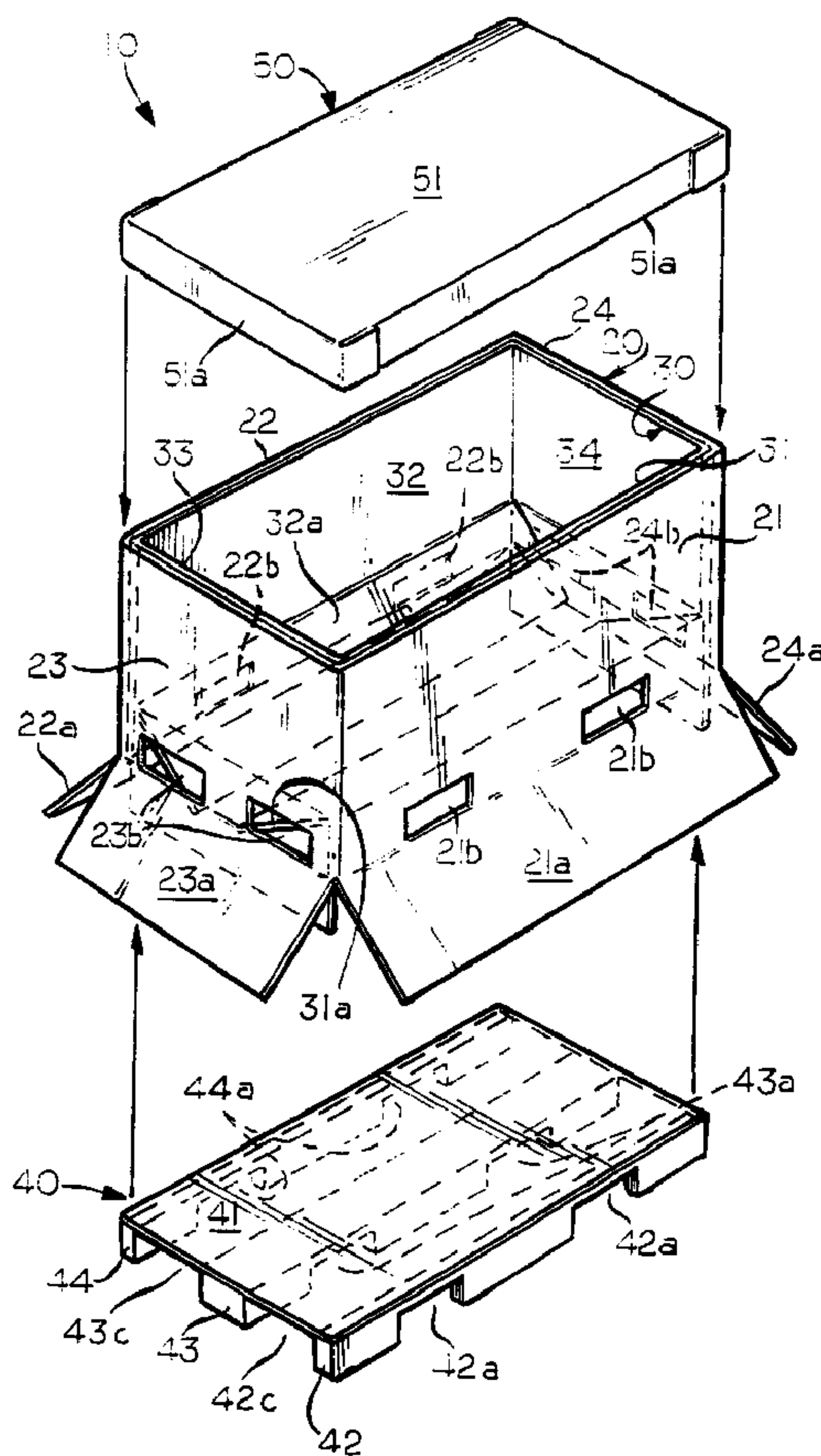

(22) Date de dépôt/Filing Date: 1998/06/25  
 (41) Mise à la disp. pub./Open to Public Insp.: 1999/07/13  
 (45) Date de délivrance/Issue Date: 2007/01/23  
 (30) Priorité/Priority: 1998/01/13 (US09/006,913)

(51) Cl.Int./Int.Cl. *B65D 5/50* (2006.01),  
*B65D 19/20* (2006.01), *B65D 19/38* (2006.01),  
*B65D 5/64* (2006.01), *B65D 77/04* (2006.01)  
 (72) Inventeurs/Inventors:  
 BRINGARD, TIMOTHY L., US;  
 GIEBEL, BUDDY E., US  
 (73) Propriétaire/Owner:  
 ACE PACKAGING SYSTEMS, INC., US  
 (74) Agent: FETHERSTONHAUGH & CO.

(54) Titre : CONTENEUR D'EXPEDITION ET METHODE DE CONSTRUCTION  
 (54) Title: SHIPPING CONTAINER SYSTEM AND METHOD OF CONSTRUCTING THE SAME



(57) **Abrégé/Abstract:**

A shipping container system and method of construction therefor are provided which includes a container with an integrated pallet assembly. The system includes an inner shell, an outer shell, a cover assembly, and a pallet assembly. The outer shell is formed from a single sheet of material, preferably high strength cardboard, and is cut and bent such that four panels are created, each

**(57) Abrégé(suite)/Abstract(continued):**

having a flap. The outer shell also has several holes located in the panels. The inner shell is formed in a similar manner, also having four panels, each with a flap. The pallet assembly includes a floor panel supported by several runners having notches. To assemble the shipping container system, the inner shell is placed within the upper portion of the outer shell and the pallet assembly is inserted into the lower portion of the outer shell. The outer shell panel flaps are then folded to provide support for the pallet assembly from underneath. The panel flaps of the inner shell are folded within the inner shell to provide support for the pallet assembly from above. So assembled, the pallet assembly is securely positioned between the flaps of the outer shell and the flaps of the inner shell. The system further includes that the holes in the outer shell panels align with the notches of the pallet assembly runners to allow the tines of a forklift or jack truck to engage the shipping container system.

ABSTRACT

A shipping container system and method of construction therefor are provided which includes a container with an integrated pallet assembly. The system includes an inner shell, an outer shell, a cover assembly, and a pallet assembly.

5 The outer shell is formed from a single sheet of material, preferably high strength cardboard, and is cut and bent such that four panels are created, each having a flap. The outer shell also has several holes located in the panels. The inner shell is formed in a similar manner, also having four panels, each with a flap. The pallet assembly includes a floor panel supported by several runners having

10 notches. To assemble the shipping container system, the inner shell is placed within the upper portion of the outer shell and the pallet assembly is inserted into the lower portion of the outer shell. The outer shell panel flaps are then folded to provide support for the pallet assembly from underneath. The panel flaps of the inner shell are folded within the inner shell to provide support for the pallet

15 assembly from above. So assembled, the pallet assembly is securely positioned between the flaps of the outer shell and the flaps of the inner shell. The system further includes that the holes in the outer shell panels align with the notches of the pallet assembly runners to allow the tines of a forklift or jack truck to engage the shipping container system.

**SHIPPING CONTAINER SYSTEM  
AND  
METHOD OF CONSTRUCTING THE SAME**

**FIELD OF THE INVENTION**

The present invention relates to a shipping container system and the method of constructing it; more specifically, to a container and method which utilizes an integrated pallet assembly to provide stability during transportation of goods using a forklift or jack truck.

**BACKGROUND**

Containers placed upon pallets are commonly used to transport a multitude of goods. Forklifts or jack trucks are used to move the pallets and containers and it is therefore necessary that the containers fit squarely on the pallets and remain in position during transportation. A typical arrangement includes a corrugated cardboard container which is placed atop a standard wooden pallet which is then moved about a warehouse, shipping dock, or other like facility.

Conventional wooden pallets are strong and easily stacked, but can be the source of a variety of problems. They are heavy, relatively expensive, and difficult to transport or recycle after use. Furthermore, cartons which are stacked upon but not fastened to the pallets in some way have a tendency to slide around on top of the pallet, thereby causing a forklift or jack truck operator to waste valuable time in rearranging the cartons. In the extreme case, the cartons may actually fall off the pallet, potentially causing damage to or destruction of the goods being transported.

29134-2

## SUMMARY

To overcome the above-mentioned problems, a shipping container system for transportation of goods and method of construction is provided which includes an integrated pallet assembly. The system includes an inner shell, an outer shell, a cover assembly, and a pallet assembly positioned between flaps of the inner and outer shells.

The inner and outer shells of the preferred embodiment are each formed from a single sheet of high strength cardboard or like material. The sheet of material is bent to form a front, rear, left, and right panel. Each panel of both the inner and outer shells is cut to form a flap. The outer shell has several holes located in the panels. The pallet assembly includes a sheet of material supported by several support members or runners. The runners define channels between each other and also have several notches cut along their lengths.

To assemble the shipping container system, the inner shell is placed within the outer shell and the pallet assembly is inserted into the lower portion of the outer shell. The outer shell flaps are then folded to support the pallet assembly from underneath. The outer shell flaps may be fastened to each other or to the bottom surface of the pallet assembly. The flaps of the inner shell are folded within the inner shell to support the pallet assembly from above. Similarly, the inner shell flaps may be fastened to each other or to the upper surface of the pallet assembly. So assembled, the pallet assembly is held securely in place between the flaps of the outer shell and the flaps of the inner shell. The system further includes the pallet assembly being disposed within the outer shell such that the holes in the outer shell align with the notches and channels of the pallet assembly runners to allow the tines of a forklift or jack truck to engage them, thereby permitting safe and stable transportation of the goods within the shipping container system.

29134-2(S)

According to one aspect of the present invention, there is provided a shipping container system, said system comprising: an outer shell, said outer shell having a front wall, a back wall, a first side wall, and a second side wall wherein said front wall is opposite said back wall and said first side wall is opposite said second side wall; an inner shell, said inner shell having a front wall, a back wall, a first side wall, and a second side wall wherein said front wall is opposite said back wall and said first side wall is opposite said second side wall, said inner shell being disposed within said outer shell; a pallet assembly, said pallet assembly comprising a floor panel and at least two support members being positioned on the underside of said floor panel, said pallet assembly being positioned within a lower portion of said outer shell, said front wall, said back wall, said first side wall and said second side wall of said outer shell each have a flap hingedly attached thereto, and said front wall, said back wall, said first side wall and said second side wall of said inner shell each have a flap hingedly attached thereto, wherein said flaps of said outer shell are folded and positioned adjacent to said support members of said pallet assembly, wherein said flaps of said inner shell are folded within said inner shell to define a substantially flat surface and are positioned adjacent to said floor panel of said pallet assembly to support the pallet assembly from one side thereof.

According to another aspect of the present invention, there is provided a shipping container, said container comprising: an outer shell; an inner shell, said inner shell being disposed within an upper portion of said outer shell; a pallet assembly, said pallet assembly positioned within a lower portion of said outer shell; a cover assembly, said cover assembly being fitted over the

29134-2(S)

upper portion of said outer shell, wherein said outer shell comprises four panels being arranged in a box configuration, each panel having a flap being hingedly attached thereto and also having a corresponding hole disposed therein, said  
5 inner shell comprising four panels being arranged in a box configuration, each panel having a flap hingedly attached thereto, wherein said flaps of said inner shell are folded to define a substantially flat surface to support said pallet assembly.

10           According to still another aspect of the present invention, there is provided a shipping container, said container comprising: an outer shell; an inner shell, said inner shell being disposed within an upper portion of said outer shell; a pallet assembly, said pallet assembly  
15 positioned within a lower portion of said outer shell; a cover assembly, said cover assembly being fitted over the upper portion of said outer shell, wherein said outer shell comprises four panels being arranged in a box configuration, each panel having a flap being hingedly attached thereto and  
20 also having a corresponding hole disposed therein, said inner shell comprising four panels being arranged in a box configuration, each panel having a flap hingedly attached thereto, wherein said pallet assembly is positioned between said flaps of said outer shell and said flaps of said inner  
25 shell and wherein said flaps define a substantially flat surface to support said pallet assembly.

It is an aspect of the present invention to provide a high-quality shipping container system and method of construction which is lightweight, inexpensive, and  
30 stable during transportation.

It is further an aspect of the present invention to provide a shipping con-

29134-2

tainer system and method of construction which utilizes a shipping carton with an integrated pallet assembly.

It is still further an aspect of the present invention to provide a shipping container system and method of construction where the pallet assembly is supported and reinforced by the shipping carton.

Additional advantages and features of the present invention will become apparent from reading the detailed description of the preferred embodiments which make reference to the following set of drawings.

### BRIEF DESCRIPTION OF THE DRAWINGS

Figure 1 shows an exploded perspective view of the present invention.

Figure 2 shows a perspective view of the assembled invention.

Figure 3 shows a sectional view taken along the line 3-3 of Figure 2.

### DETAILED DESCRIPTION

Referring now to **Figures 1-3**, a shipping container system is provided which is generally referred to by the reference numeral **10**. The shipping container system **10** includes an outer shell **20**, an inner shell **30**, a pallet assembly **40**, and a cover assembly **50**, to be described further herein.

With respect to the orientation shown in **Figures 1 and 2**, the outer shell **20** has a generally rectangular horizontal cross section and includes a front panel **21**, a rear panel **22**, a left side panel **23**, and a right side panel **24**. Each of the panels **21-24** of the outer shell **20** in turn includes a corresponding flap; that is, the front panel **21** includes a flap **21a**, the rear panel **22** includes a flap **22a**, the left side panel **23** includes a flap **23a**, and the right side panel **24** includes a flap **24a**. Each of the panels **21-24** also contains holes **21b-24b**, respectively. The outer shell **20** of the preferred embodiment is constructed of a single sheet of corrugated cardboard, plastic, or any other material with suitable structural and load bearing qualities which is cut and bent to form the flaps **21a-24a** and the holes **21b-24b**.

The configuration of the inner shell **30** is similar to that of the outer shell



29134-2 (S)

20. The inner shell 30 also has a generally rectangular horizontal cross section and includes a front panel 31, a rear panel 32, a left side panel 33, and a right side panel 34. Each of the panels 31-34 of the inner shell 30 also includes a corresponding flap; that is, the front panel 31 includes a flap 31a, the rear panel 32 includes a flap 32a, the left side panel 33 includes a flap 33a, and the right side panel 34 includes a flap 34a. However, there are no holes in the inner shell 30 which correspond to those in the outer shell 20. Like the outer shell 20, the inner shell 30 is also constructed of single sheet of cardboard, plastic, or the like, and then cut and bent to form the flaps 31a-34a. The inner shell 30 is constructed such that its outer dimensions are slightly smaller than the inner dimensions of the outer shell 20 so that the inner shell 30 can fit tightly within the outer shell 20, as shown in Figures 1 and 3. Furthermore, the inner shell 30 is slightly shorter in the vertical direction than the outer shell 20 (the difference between the height of the outer shell 20 and the inner shell 30 is about the same as the height of the pallet assembly 40).

The pallet assembly 40 of the preferred embodiment includes a floor panel 41, a front runner 42, a center runner 43, and a rear runner 44. The floor panel 41 and runners 42-44 may be constructed of a material similar or identical to that used to construct the outer shell 20 or the inner shell 30. The runners 42-44 are elongate and are attached to the underside of the floor panel 41 using glue, nails, screws, or the like and extend the length of the floor panel 41 to provide structural support. Alternatively, the runners 42-44 may be formed as an integral part of the floor panel 41. The front runner 42 also includes notches 42a; the center runner 43 and the rear runner 44 contain similar notches 43a and 44a, respectively (shown in phantom in Figure 1). Notches 42a-44a are aligned to allow the tines of a forklift or jack truck to engage the pallet assembly 40. The front runner 42 and center runner 43 define a channel 42c between the two. Similarly, the center runner 43 and the rear runner 44 define a channel 43c between the two. The channels 42c and 43c allow forklift access from either side of the shipping container system 10. The outer dimensions of the pallet assembly 40 are substantially identical to those of the inner shell 30 so that the pallet assembly

**40** can fit tightly within the lower portion of the outer shell **20**.

The final component of the shipping container system **10** is a cover assembly **50**. The cover assembly **50** includes a top panel **51** which has four flaps **51a**, as shown in **Figures 1** and **3**. The cover assembly **50** of the preferred embodiment is also constructed of a single sheet of material such as cardboard or plastic. The top panel **51** is then cut and bent appropriately to form the flaps **51a** which are secured to each other as shown using glue, staples, or like fastening means. The cover assembly **50** is constructed such that its inner dimensions are slightly larger than the outer dimensions of the outer shell **20** so that the cover assembly **50** will fit tightly around the upper portion of the outer shell assembly **20**, thus forming a lid.

The final assembled configuration of the preferred embodiment of the shipping container system **10** is as follows, best shown in **Figure 1**. The pallet assembly **40** is positioned inside the lower portion of the outer shell **20** such that the bottom of the outer shell **20** and the bottom of the pallet assembly **40** are generally aligned. The outer shell flaps **21a-24a** are folded such that they provide support for the pallet assembly **40** from underneath, best shown in **Figure 3**. The sequence of folding the flaps **21a-24a** is unimportant and may be varied without affecting the structural integrity of the shipping container system **10**. The flaps **21a-24a** are then fastened to each other or to the lower surfaces of the runners **42-44** using glue, staples, or the like. Furthermore, the holes **21b** and **22b** of the outer shell **20** align with the corresponding notches **42a-44a**. Similarly, the holes **23b** and **24b** of the outer shell **20** align with the channels **42c** and **43c**, shown best in **Figure 2**, which allows the tines of a forklift to engage the shipping container system **10** for transportation.

After the pallet assembly **40** is correctly positioned inside the outer shell **20**, the inner shell **30** is positioned within the upper portion of the outer shell **20**, as shown in **Figure 1**. The flaps **31a-34a** of the inner shell **30** are folded down such that the pallet assembly **40** is secured between the flaps **21a-24a** of the outer shell **20** and the flaps **31a-34a** of the inner shell **30**. Again, the sequence of folding the flaps **31a-34a** is not important as long as all four flaps **31a-34a** form

a relatively flat surface to provide support to the pallet assembly **40** from above. The flaps **31a-34a** of the inner shell **30** may be then fastened to each other or to the upper surface of the floor panel **41** using glue, staples, or an equivalent means. Alternatively, the inner shell **30** may be positioned within the upper portion of the outer shell **20** prior to positioning the pallet assembly **40** inside the lower portion of the outer shell **20**.

With the shipping container system **10** correctly assembled, it is ready to receive goods. When the shipping container system **10** is filled to the desired capacity, the cover assembly **50** may be placed over the open top portion to prevent spillage during transportation.

Although the best mode contemplated by the inventor for carrying out the present invention as of the filing date hereof has been shown and described herein, it will be apparent to those skilled in the art that suitable modifications, variations, and equivalents may be made without departing from the scope of the invention, such scope being limited solely by the terms of the following claims.

29134-2(S)

CLAIMS:

1. A shipping container system, said system comprising:

an outer shell, said outer shell having a front  
5 wall, a back wall, a first side wall, and a second side wall  
wherein said front wall is opposite said back wall and said  
first side wall is opposite said second side wall;

an inner shell, said inner shell having a front  
wall, a back wall, a first side wall, and a second side wall  
10 wherein said front wall is opposite said back wall and said  
first side wall is opposite said second side wall, said  
inner shell being disposed within said outer shell;

a pallet assembly, said pallet assembly comprising  
a floor panel and at least two support members being  
15 positioned on the underside of said floor panel, said pallet  
assembly being positioned within a lower portion of said  
outer shell,

said front wall, said back wall, said first side  
wall and said second side wall of said outer shell each have  
20 a flap hingedly attached thereto, and

said front wall, said back wall, said first side  
wall and said second side wall of said inner shell each have  
a flap hingedly attached thereto,

wherein said flaps of said outer shell are folded  
25 and positioned adjacent to said support members of said  
pallet assembly, wherein said flaps of said inner shell are  
folded within said inner shell to define a substantially  
flat surface and are positioned adjacent to said floor panel

29134-2(S)

of said pallet assembly to support the pallet assembly from one side thereof.

2. The system according to claim 1 wherein said outer shell further comprises a plurality of holes, said plurality  
5 of holes being located in said front wall, said back wall, said first side wall and said second side wall of said outer shell.

3. The system according to claim 2 wherein said pallet assembly further comprises a plurality of notches  
10 being located in said support members.

4. The system according to claim 3 wherein said plurality of holes in said outer shell align with said plurality of notches in said pallet assembly.

5. A shipping container, said container comprising:  
15 an outer shell;

an inner shell, said inner shell being disposed within an upper portion of said outer shell;

a pallet assembly, said pallet assembly positioned within a lower portion of said outer shell;

20 a cover assembly, said cover assembly being fitted over the upper portion of said outer shell, wherein said outer shell comprises four panels being arranged in a box configuration, each panel having a flap being hingedly attached thereto and also having a corresponding hole  
25 disposed therein,

said inner shell comprising four panels being arranged in a box configuration, each panel having a flap hingedly attached thereto, wherein said flaps of said inner

29134-2(S)

shell are folded to define a substantially flat surface to support said pallet assembly.

6. The container according to claim 5 wherein said pallet assembly comprises:

5 a floor panel, said floor panel comprising a sheet of generally rigid material having a top surface and a bottom surface; and

a plurality of runners, said plurality of runners extending from the bottom surface of said floor panel, each  
10 runner having a plurality of notches disposed therein.

7. The container according to claim 6 wherein said holes in said side panels of said outer shell align with said notches in said runners of said pallet assembly.

8. The container according to claim 5 wherein said  
15 flaps of said outer shell are folded to provide a surface to support said pallet assembly.

9. A shipping container, said container comprising:

an outer shell;

an inner shell, said inner shell being disposed  
20 within an upper portion of said outer shell;

a pallet assembly, said pallet assembly positioned within a lower portion of said outer shell;

a cover assembly, said cover assembly being fitted over the upper portion of said outer shell, wherein said  
25 outer shell comprises four panels being arranged in a box configuration, each panel having a flap being hingedly

29134-2 (S)

attached thereto and also having a corresponding hole disposed therein,

said inner shell comprising four panels being arranged in a box configuration, each panel having a flap hingedly attached thereto, wherein said pallet assembly is positioned between said flaps of said outer shell and said flaps of said inner shell and wherein said flaps define a substantially flat surface to support said pallet assembly.

10. The container according to claim 9 wherein said pallet assembly comprises:

a floor panel, said floor panel comprising a sheet of generally rigid material having a top surface and a bottom surface; and

a plurality of runners, said plurality of runners extending from the bottom surface of said floor panel, each runner having a plurality of notches disposed therein.

11. The container according to claim 10 wherein said holes in said side panels of said outer shell align with said notches in said runners of said pallet assembly.

12. The container according to claim 9 wherein said flaps of said outer shell are folded to provide a surface to support said pallet assembly.

FETHERSTONHAUGH & CO.

OTTAWA, CANADA

PATENT AGENTS

FIG. 1

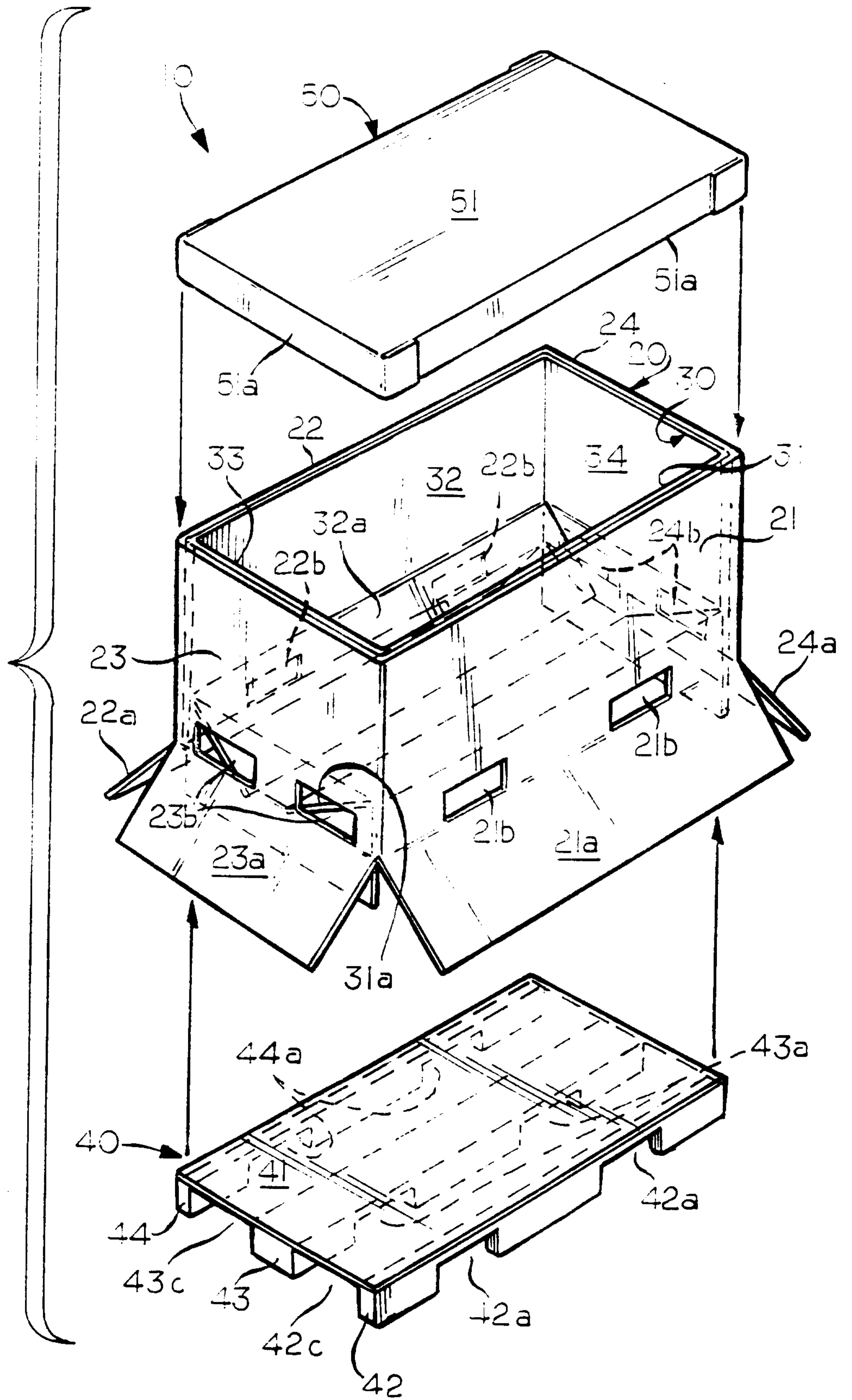



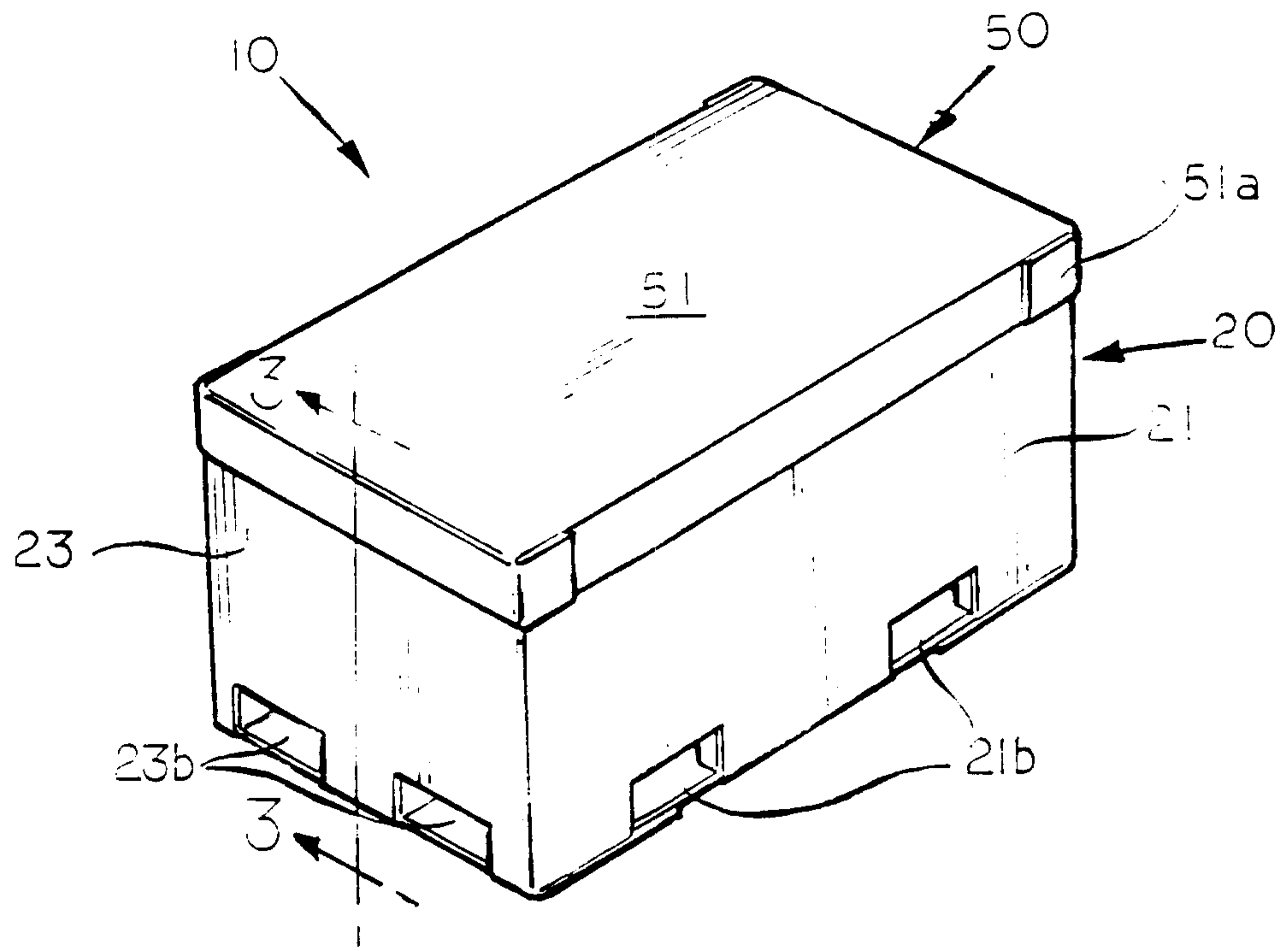

FIG. 2  
+

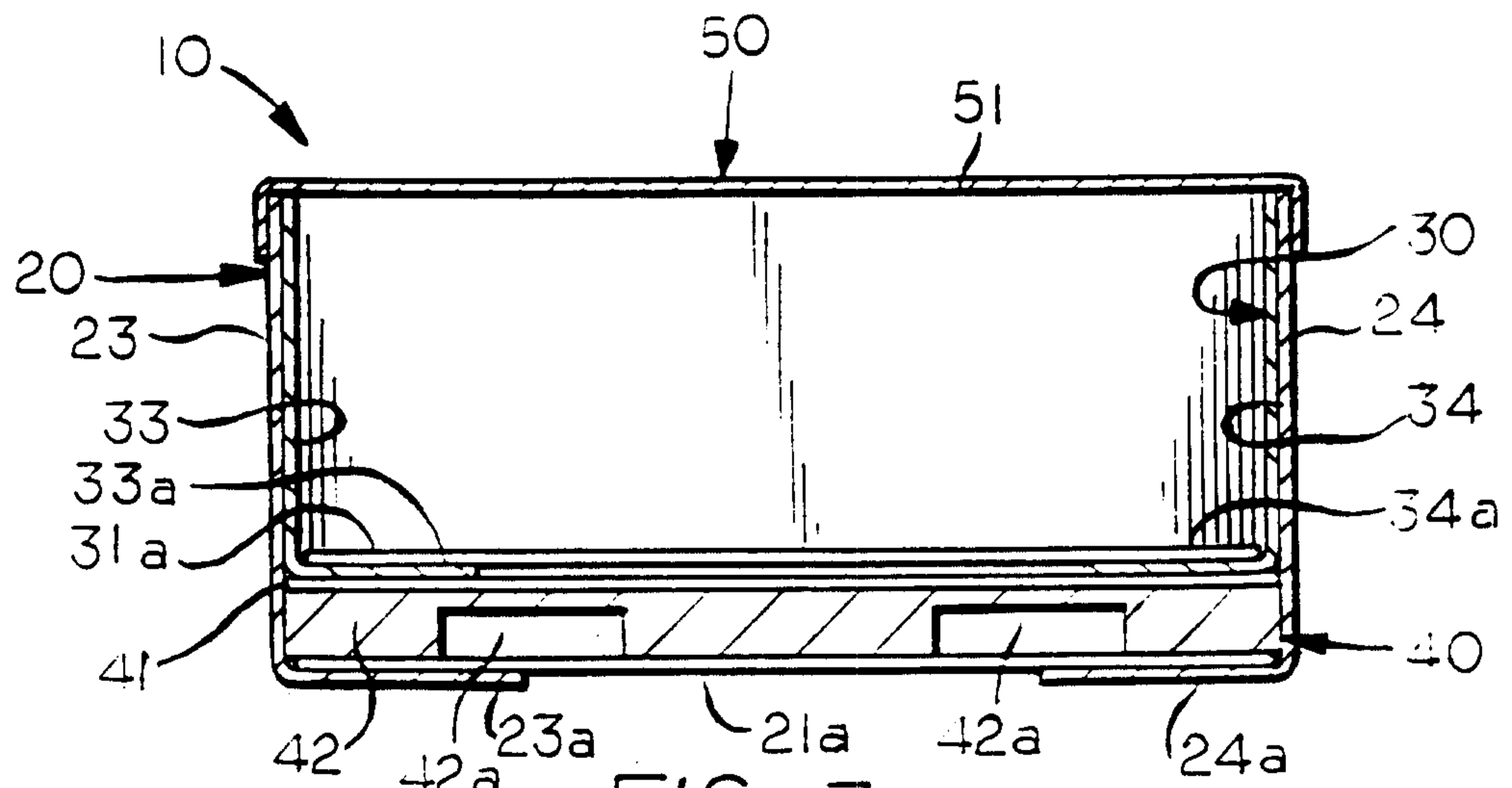

FIG. 3

