

(21) Application No 8317235

(22) Date of filing  
24 Jun 1983

(30) Priority data

(31) 8218694

(32) 28 Jun 1982

(33) United Kingdom (GB)

(43) Application published  
18 Jan 1984

(51) INT CL<sup>3</sup> B63B 21/66

(52) Domestic classification  
B7V HS  
U1S 1022 1199 2141  
B7V

(56) Documents cited

GB A 2017030

WO A 8103475

US 3613626

US 3605674

US 3560912

US 3062171

(58) Field of search

B7V

(71) Applicant

Seismograph Service

(England) Limited

(United Kingdom)

Holwood

Westerham Road

Keston

Kent BR2 6HD

(72) Inventor

Jacobus Johannes

Breugelmans

(74) Agent and/or Address for  
Service

Stanley Popplewell

Poole

57 Lincoln's Inn Fields

London WC2A 3LS

(54) Improved pelagic trawl door  
or paravane

(57) A paravane 1 having a hydro-foil profile and towing means comprising a 3 leg bridle 2, 6 adapted for attachment to a tow line for towing the paravane through water, which paravane includes control means 7, 8 whereby the angle of attack of the paravane during its passage through the water can be remotely controlled, by moving the end of leg 6 along slide 8.

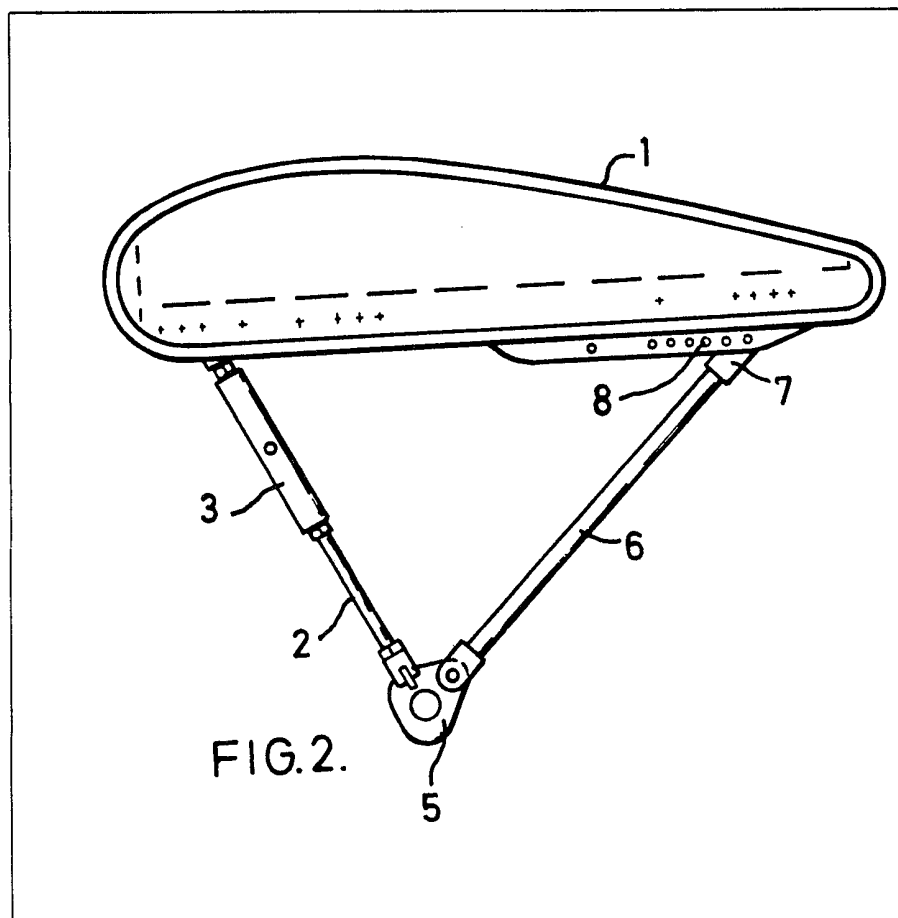

GB 2 122 562 A

1/4

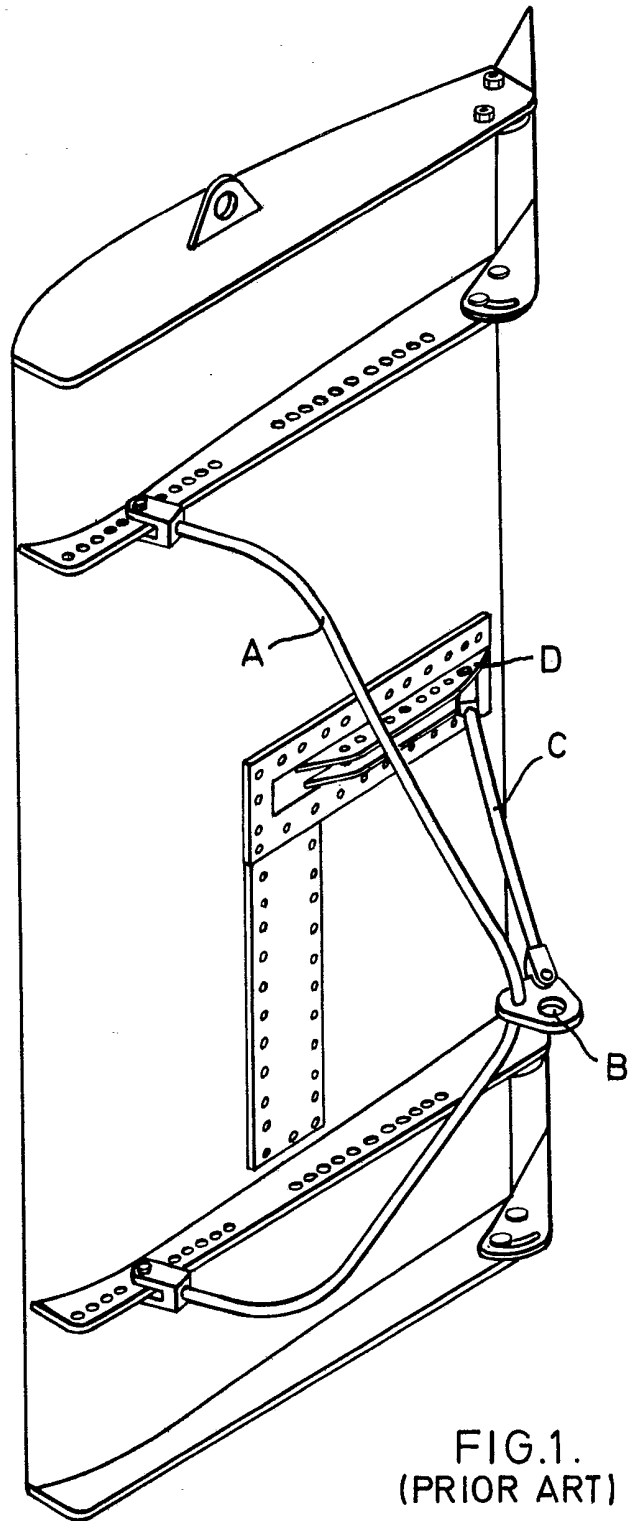

FIG.1.  
(PRIOR ART)

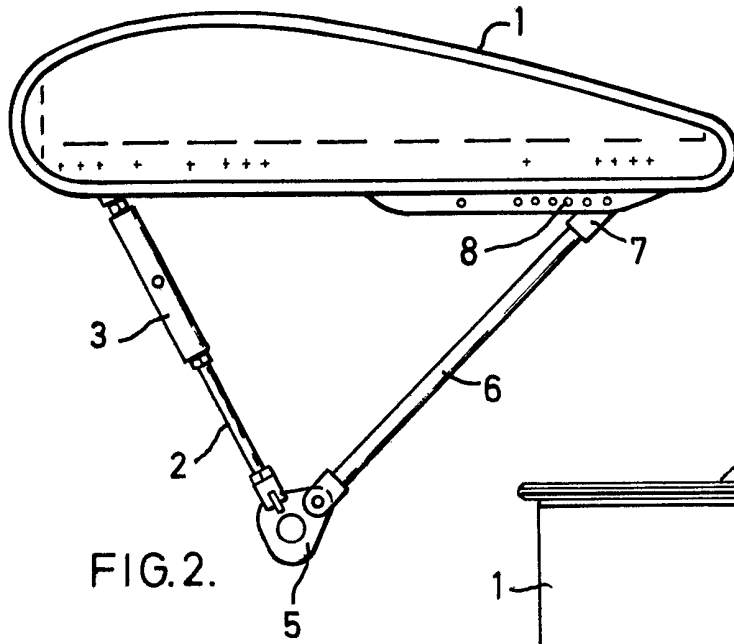

FIG. 2.

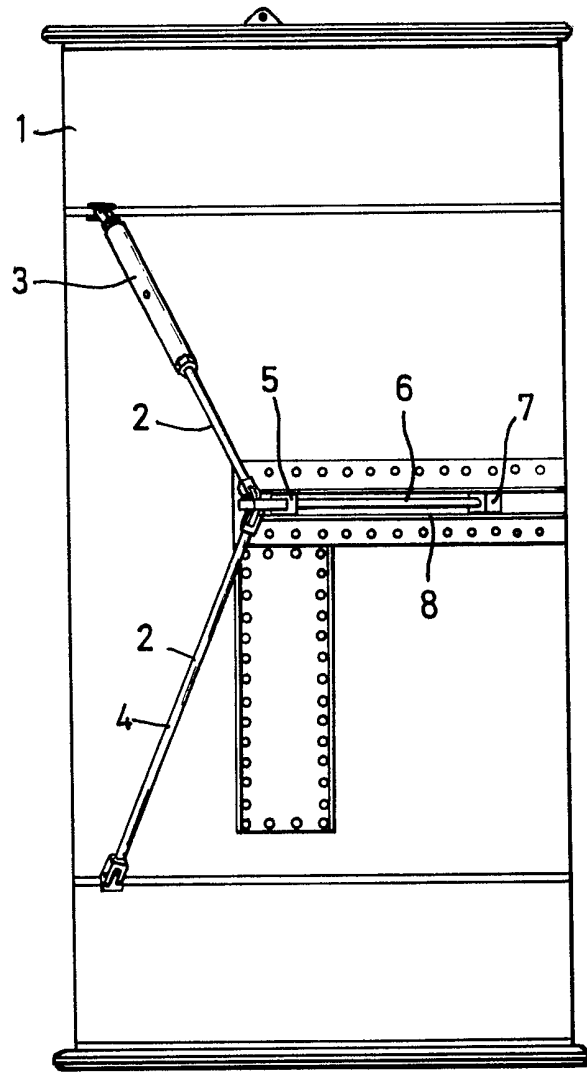

FIG. 3.

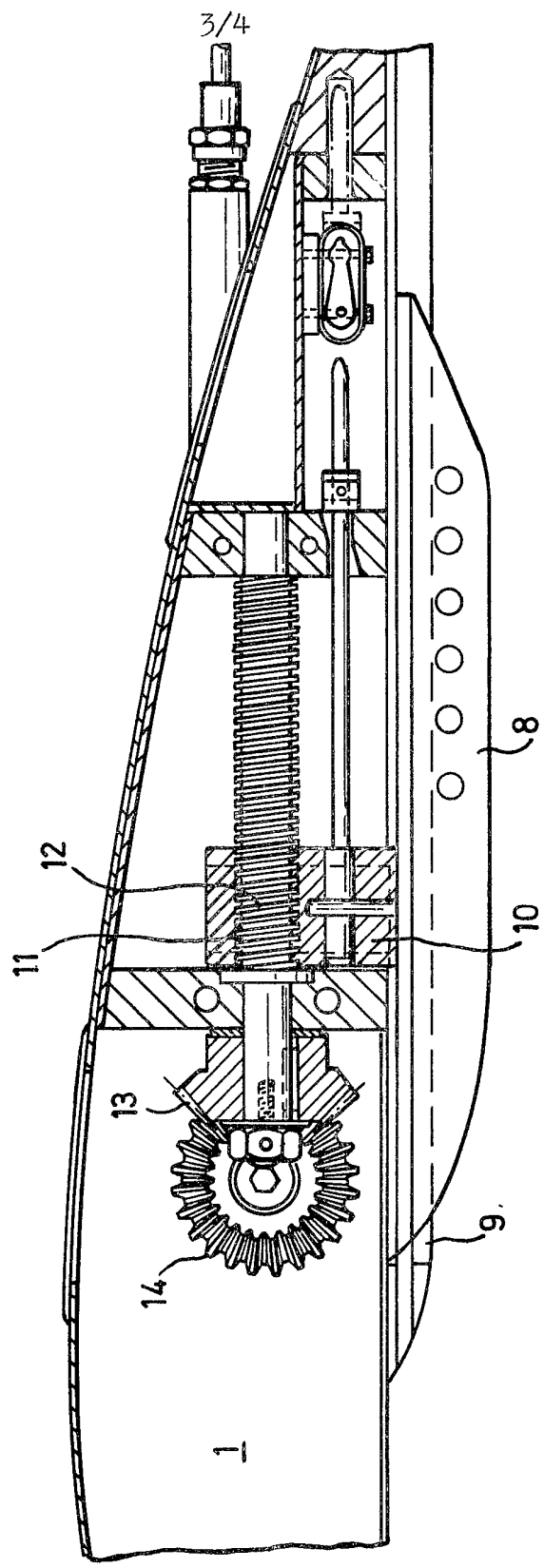

FIG. 4.

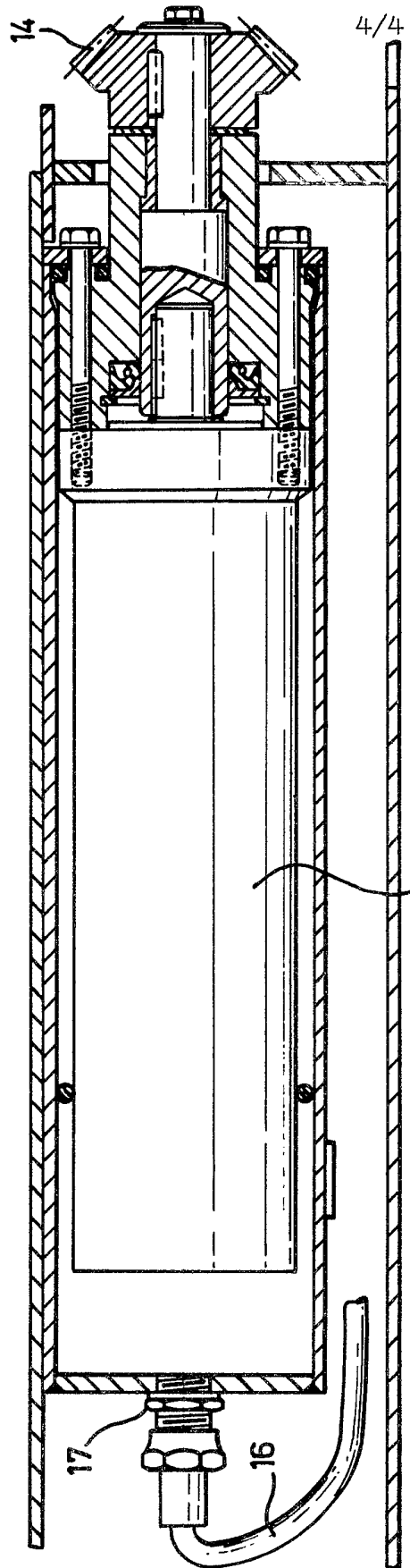

FIG. 5.

## SPECIFICATION

### Improved pelagic trawl door or paravane

- 5 This invention relates to an improved pelagic trawl door or paravane.

The problem of diverting objects from their natural path when under tow is not new.

- 10 Fishermen when trawling need to ensure that the mouth of the trawl net is open. The navy when sweeping for mines needs to ensure that a sufficient width of the sea bed is covered by the cutting cable behind the vessel.

- 15 In seismic surveys which used high explosives it was necessary to ensure that the explosion was offset far enough from the survey scale.

- 20 The primary device used for the purpose of diversion is the pelagic trawl door or paravane. This device, which has a hydrofoil profile, is towed in a vertical orientation with the profile set at an angle to the towing direction. The flow of water over the vertical hydrofoil profile sets up a force which thrusts the device outwards from the towing vessel's direction of motion. The amount of diversion is controlled by the velocity of the vessel through the water and by the angle of attack of the leading edge of the trawl door.

- 30 A mechanism which has been used prior to this invention is shown in Fig. 1 of the accompanying drawings. A 'V' shaped bar or bridle (A) is attached to the trawl door so that the 'V' lies in a vertical plane. Towing means, which is attached to the towing vessel is attached to the apex (B) of the 'V'. Also, at this point, is attached a bar (C) which is sufficiently long to reach the middle section of the trawl door. This bar is fitted with a bolt hole through which can be passed a bolt. A horizontal metal member (D) is secured across the inner face of the trawl door. In this metal member (D) there is a series of holes of sufficient diameter to take a bolt of sufficient strength to withstand the diverting forces. These holes are spaced at such an interval as to ensure adequate material strength in the structure. A suitable hole is chosen for a particular diversion required and, by means of a bolt, the bar (C) is attached to the member (D).

- 55 In order to change the amount of diversion it is necessary to bring the complete device together with the equipment being diverted on board the towing vessel and change the point of attachment.

- 60 With the development of arrays of seismic sources it has become possible to apply antenna theory to the design of the optimum array configuration. In order to achieve this optimum it is necessary to ensure that individual sub-arrays are towed at distances from the line of traverse of the survey vessel which are closely controlled. In addition, the size and

complexity of the sub-array is such that the bringing in-board of the system becomes very difficult and time-consuming.

- 70 It is an object of the present invention to dispense with the need for the trawl door to be recovered. A further object of the present invention is the achievement of a finer degree of control of the diversion than is possible with the prior art method discussed above.

- 75 According to the present invention there is provided a pelagic trawl door or paravane having a hydrofoil profile and towing means adapted for attachment to a tow line for towing the paravane through the water, which paravane includes control means whereby the angle of attack of the paravane during its passage through the water can be remotely controlled.

- 80 Preferably the control means comprise a bridle movable relative to the paravane by means of a lead screw, and an electric motor for rotating said lead screw. It will be appreciated that other means for rotating the lead screw could be employed such as for example a hydraulic motor.

- 85 An embodiment of the paravane of the present invention will now be described, by way of example only, by reference to Figs. 2 to 5 of the accompanying drawings, in which:

- 95 *Figure 1* is a perspective view of a prior art paravane already discussed,

*Figure 2* is a plan of a paravane according to the present invention,

- 100 *Figure 3* is a side elevation of the paravane of Fig. 2,

*Figure 4* is a sectional detail of the mechanism employed to move the bridle of the paravane of Fig. 2 and

- 105 *Figure 5* is a sectional detail of the electric motor employed to drive the bridle-moving mechanism of Fig. 4.

- Referring to Figs. 2 to 5 of the drawings, a pelagic trawl door or paravane 1 of generally hydrofoil cross-section is provided with a three leg bridle 2. Legs 3 and 4 are pivotally attached both to the paravane 1 and to the bridle head 5. The third leg 6 is pivotally attached to the bridle head 5 and pivotally attached at its other end 7 to a longitudinally extending slide element 8. The slide element 8, which is constrained to slide along a fore-and-aft track by guides 9, is affixed to a block 10 having a threaded aperture 11. A lead screw 12 passes through and engages with the threaded aperture 11 and the lead screw is fixed against axial movement but journaled for rotation within the body of the paravane. A bevel gear 13 is mounted at one end of the lead screw 12, cooperating with a further bevel gear 14 which is mounted upon the output shaft of an electric motor 15. The electric motor, which is preferably one such as is obtainable for Lucas Aerospace is encased within a housing sealed against ingress of water. A waterproof electrical supply and con-

trol cable 16 passes into the paravane at 17 and hence into the motor *via* connection on the housing.

In operation, the paravane 1 is attached to a tow line by means of bridle head 5 and to an electric power source by means of electrical supply 16. The paravane travels through the water in a vertical orientation at an angle of attack dictated by the position of the pivot point 7 of the third leg 6 of the bridle 2. By rotating the lead screw 12, the slider element 8 and the pivot point 7 can be moved longitudinally forwards or backwards thus to increase or decrease respectively the angle of attack of the paravane in the water. A  $4\frac{1}{2}$ " travel of the block 10 and slider element 8 has been found to be satisfactory.

The paravane can include various sensing devices for measuring such parameters as depth, velocity through the water, angle of attack etc. and these values can be relayed to a towing vessel which can be provided with all necessary monitoring control apparatus and switch gear.

It will be realized that the apparatus of the present invention enables the angle of attack of the paravane to be altered without bringing the unit in-board. Furthermore, the angle of attack is continuously variable over its range, unlike the prior art apparatus discussed hereinbefore.

Moreover, as comprehended within the definition of the invention hereinbefore, the paravane of the present invention is not restricted to use in a vertical orientation. By suitable location of the towing means on the paravanes the paravane can be arranged to travel in a horizontal orientation, in which case operation of the control means to alter the angle of attack of the paravane with respect to the water through which it passes will cause the paravane to travel more shallowly or more deeply through the water. In other words, by using the paravane in other than a vertical orientation, the operation of the control means can enable the paravane to function as a depth controller. The operation of the control means can be effected manually or automatically, e.g. by employing a pressure depth gauge or other depth sensing means.

#### CLAIMS

1. A pelagic trawl door or paravane having a hydrofoil profile and towing means adapted for attachment to a tow line for towing the paravane through water, which paravane includes control means whereby the angle of attack of the paravane during its passage through the water can be remotely controlled.

2. A pelagic trawl door or paravane according to Claim 1, wherein the control means comprises a movable bridle, a lead screw arranged to move the bridle upon rotation of the lead screw and rotation means for rotating

the lead screw, whereby the position of the bridle relative to the paravane is adjustable by rotation of the lead screw.

3. A pelagic trawl door or paravane according to Claim 2, wherein said rotation means comprises an electric motor.

4. A pelagic trawl door or paravane according to Claim 2, wherein said rotation means comprises a hydraulic motor.

5. A pelagic trawl door or paravane according to Claim 2, wherein the bridle is provided with three legs and a bridlehead, two of said legs being pivotally attached to the paravane and to the bridlehead and the third leg being pivotally attached to the bridlehead and to a slide element mounted on the paravane for sliding movement relative thereto, said slide element being adapted for cooperation with said lead screw, whereby rotation of the lead screw causes movement of the slide element to move the position of the bridlehead relative to the paravane.

6. A pelagic trawl door or paravane according to Claim 1, wherein the paravane includes a sensing device for sensing information about the paravane and for relaying this information to a remote control point.

7. A pelagic trawl door or paravane according to Claim 6, wherein said sensing device is selected from one or more of the group consisting of a depth sensor, a velocity indicator, and an angle of attack sensor.

8. A pelagic trawl door or paravane according to Claim 1, which is provided with electrical connections whereby control signals can be passed to the paravane from a remote control point via an electric cable to control the angle of attack of the paravane.

9. A pelagic trawl door or paravane according to Claim 1, wherein a two position towing means is provided on the paravane such that in use the paravane can selectively adopt either a generally vertical orientation or a generally horizontal orientation.

10. A pelagic trawl door or paravane according to Claim 1 and arranged for use in a generally horizontal position, alteration of the angle of attack of the paravane during its passage through the water causing a change of depth of the paravane in the water.

11. A pelagic trawl door or paravane according to Claim 10, wherein depth sensing means are provided, adapted in use to control automatically the depth of the paravane in the water.

12. A pelagic trawl door or paravane having a hydrofoil profile and towing means adapted for attachment to a tow line for towing the paravane through water, said towing means including a bridle head movable relative to the paravane for altering the angle of attack of the paravane in the water adjustable support means for supporting and moving said bridle head relative to said paravane and adjusting means for adjusting the support

means whilst the paravane is in use in the water.

13. A pelagic trawl door or paravane according to Claim 12, which is adapted to generally horizontally disposed in use whereby movement of the bridle head causes an alteration in depth of the paravane in the water.

14. A pelagic trawl door or paravane according to Claim 13, wherein means are provided for automatically controlling the depth of the paravane in the water.

15. A pelagic trawl door or paravane substantially as hereinbefore described with reference to Figs. 2 to 5 of the accompanying drawings.

16. The features hereinbefore disclosed, or their equivalents, in any novel selection.

---

Printed for Her Majesty's Stationery Office  
by Burgess & Son (Abingdon) Ltd.—1984.  
Published at The Patent Office, 25 Southampton Buildings,  
London, WC2A 1AY, from which copies may be obtained.