

(21) Application No 8912741.9

(22) Date of filing 08.06.1989

(71) Applicant
Blakecare Limited

(Incorporated in the United Kingdom)

**56 The Quadrangle, Sussex Gardens, London,
W2 2RW, United Kingdom**

(72) Inventor
Klaus Engels

(74) Agent and/or Address for Service
Saunders & Dolleymore
**9 Rickmansworth Road, Watford, Herts, WD1 7HE,
United Kingdom**

(51) INT CL⁵
G09F 27/00

(52) UK CL (Edition K)
G5C CJA CJD

(56) Documents cited
GB 1276724 A EP 0337902 A US 4853678 A

(58) Field of search
UK CL (Edition K) **G5C CAD CAE CDBF CDBK
CDBP CDBX CJA CJD**
INT CL⁵ **G09F**

(54) **Display device**

(57) An advertising display cabinet has a hinged front door comprising a half-silvered mirror, behind which is an array of open-fronted cells each containing a halogen lamp. Interposed between the open front of each cell and the mirror is a light-transmissive picture. Photo-sensors disposed behind the mirror detect the presence of a person in front of the mirror, and activate a controller which energises one or more halogen lamps in the cells to cause predetermined back-projected picture images to be seen by the person. The controller also activates a tape cassette player so as to provide simultaneously an appropriate commentary. The individual pictures may be replaced by rolls or cassettes from which pictures may be selected. The respective cells and associated lamps and pictures may each take the form of a film projector, or an electronic video apparatus, arranged to project a picture image on to the rear surface of the mirror.

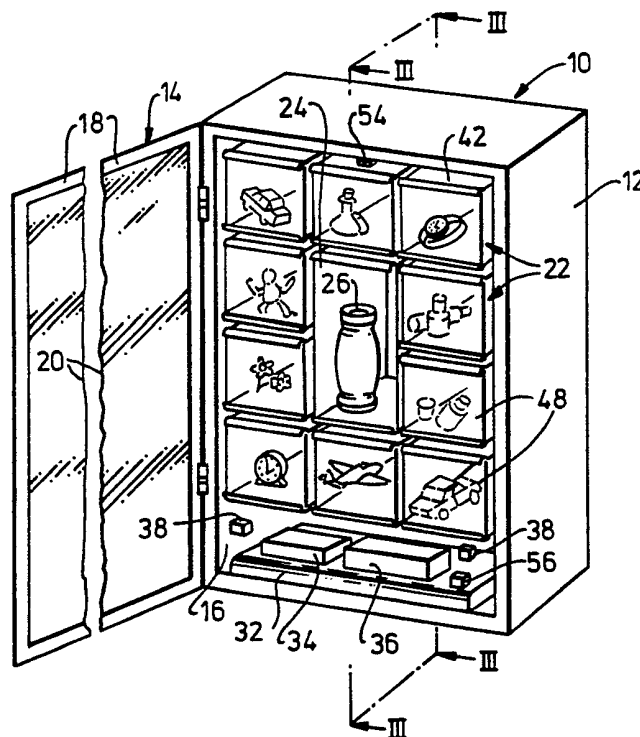

FIG. 2

1/3

FIG.1(a)

FIG.1(b)

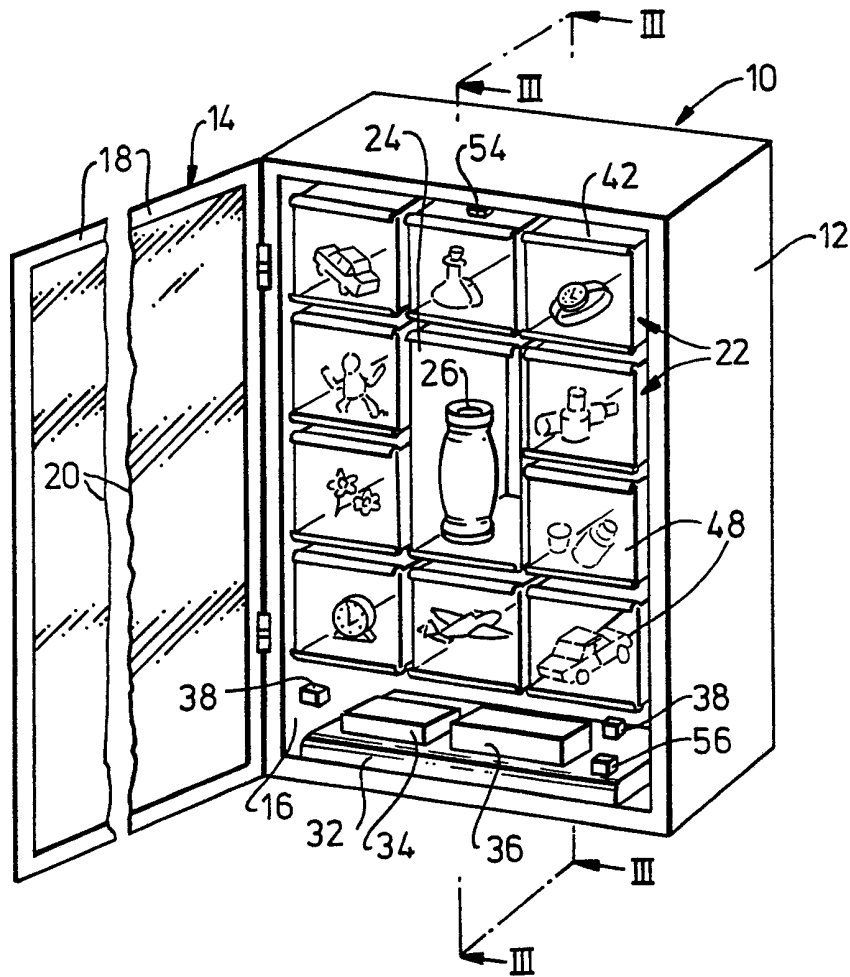
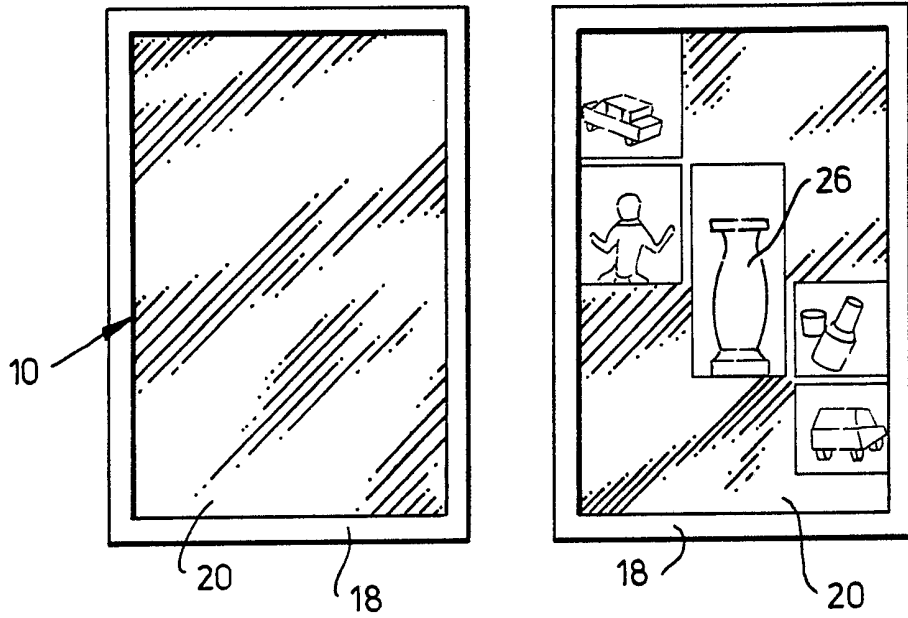

FIG. 2

FIG. 3

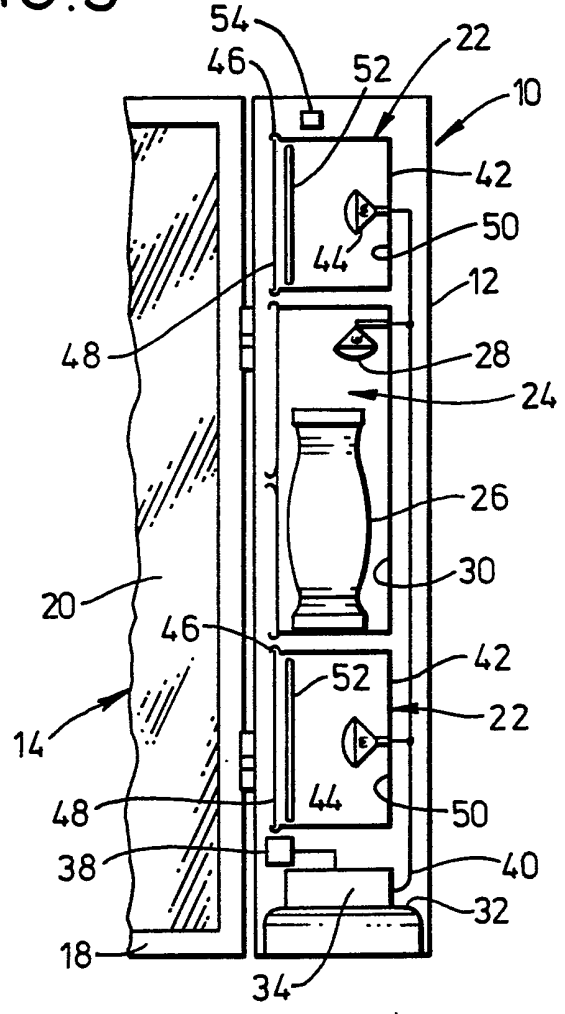

FIG. 4

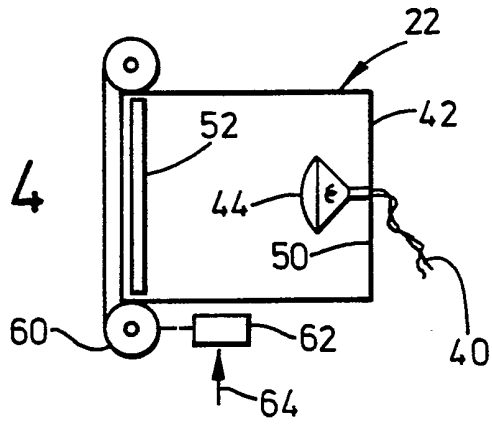
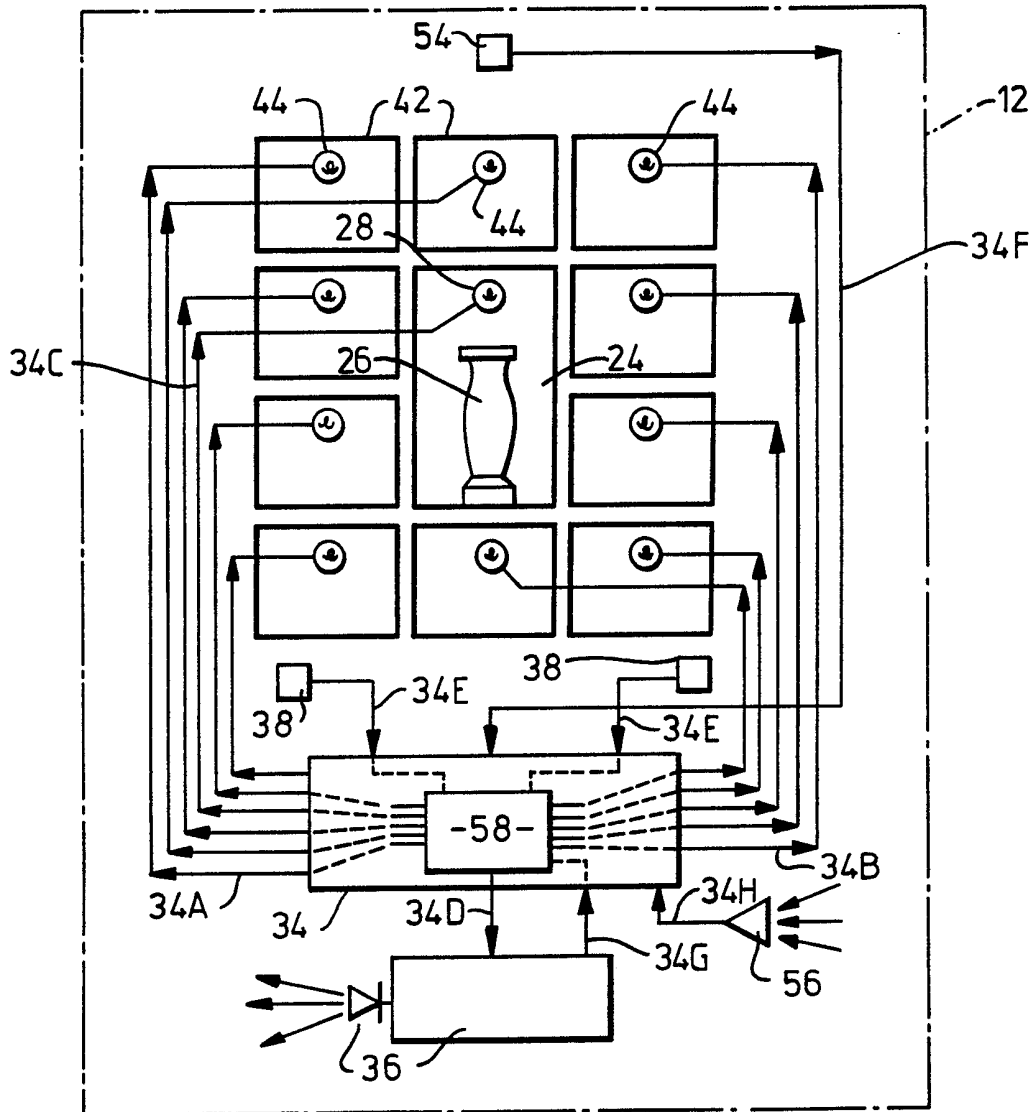

FIG. 5



DISPLAY DEVICE

This invention relates to a display device that has its primary field of utility in the field of advertising, though it may be used in any other relevant domestic, business or industrial field of activity.

In the past, mirrors have been used in advertising displays to attract attention, to provide rear views of objects placed in front of them, and to generally enhance the aesthetic appeal of the display. Moreover, such mirrors have been used in conjunction with hidden lighting disposed in front of them for the purpose of illuminating such objects. In those displays, the mirror has played an entirely passive, though attractive background role.

"Half-silvered" mirrors have been used, for example, in commercial and business premises to give privacy to staff working in an office area which is located adjacent a public access area. Provided that the illumination level in the office area is lower than that in the public access area, staff in the office can observe the public without themselves being seen by the public.

According to one aspect of the present invention, a display device includes a decorative panel or screen, for example, a mirror of the half-silvered kind. Behind that panel or mirror is disposed an array of open-fronted cells, and in each cell there is provided a controllable source of illumination. The cells are constructed of a light-opaque material, so that light in one cell cannot reach other cells. Each of some or all of the cells is provided at or near its open-fronted end with a picture support for holding a light-transmissive picture in a position disposed between the light source and the rear face of the panel or mirror, so that on illumination of the cell an image of the picture may be seen from the front, viewing face of the panel or mirror, instead of the normal appearance of the panel, or the reflection of light emanating from positions in front of the mirror. An electrical controller disposed preferably behind the panel or mirror is arranged to

control, when activated, the illumination sources in the respective cells in a predetermined manner, and a proximity sensor disposed preferably behind the panel or mirror is arranged to activate the controller whenever a person
5 closely approaches the panel or mirror, thereby to cause the controller to illuminate in time sequence different cells or different combinations of two or more cells.

With such a display device, a person approaching the panel or mirror at a distance sees only its normal
10 front-lighted appearance or a normal mirror reflecting the scene in front of it. However, on closer approach to the panel or mirror, the proximity sensor responds to the presence of the person, and activates the controller to cause it thereupon to energise in a preferably pre-
15 programmed time sequence the respective light sources so as to achieve illumination of the respective cells in predetermined sequence, or in a predetermined sequence of different combinations of cells.

Illumination of each cell is at such a level that
20 the image of the light-transmissive picture supported at the open front of the cell is rendered visible through the adjacent part of the panel or mirror, in place of the front appearance or reflection that is normally seen there.

Each of such cells may include a magnifying means
25 for magnifying the picture so as to provide an enlarged image thereof on the rear surface of the panel or mirror.

If desired, and as an alternative, in place of a half-silvered mirror there may be used instead a normally opaque, preferably reflecting, panel which has been
30 prepared by treating a transparent substrate (e.g. glass, or a plastics film or rigid sheet) with a paint or dye in a manner analogous to that used in producing a half-silvered mirror, so that back-projected images may be visible to a person in front of the panel.

In another alternative, the panel may comprise a
35 tinted glass panel, or a fine screen of a natural or man-made textile fabric (e.g. a muslin), with or without a protective glass or other transparent sheet, preferably tightly stretched on a frame. Such a fabric may be plain

and of a single colour, or it may carry a multi-coloured pattern.

5 The proximity sensor preferably comprises a photo-responsive sensor arranged to respond to the light reaching it through the panel or mirror. With such a sensor, the light falling on it diminishes when a person approaches the panel or mirror, since that person in effect casts a shadow over the sensor.

10 Additional proximity sensors may be provided so as to sense persons approaching from different directions.

The controller is preferably also arranged to activate an audio tape cassette player so as to initiate a spoken commentary concerning the subject matter portrayed by the respective illuminated cells or combinations thereof. The cassette player is preferably arranged to supply control signals to the controller so as to cause it to effect a change in the illuminated cell or the combination of illuminated cells whenever necessary for the coordination of changes in the display of visual images with changes in the subject matter of the spoken commentary.

20 Alternatively, the controller may supply control signals to the cassette player so as to select spoken commentary appropriate to a change of illuminated cell or a changed combination of illuminated cells. In this case, the controller may be pre-programmed to effect a predetermined sequence of illuminated cells or combinations of illuminated cells; or it may be programmed to select on a random basis the next combination of illuminated cells. In this latter case, the cassette player would be arranged to provide at the end of each piece of spoken commentary a control signal for causing the controller to select the next illuminated cell or combination of illuminated cells, and in turn the controller would provide the cassette player with the identity of the section of commentary to be played.

35 Illumination of the respective cells may be achieved by high intensity electric light bulbs (e.g. of the halogen kind), and the cells may be provided, as

required, with rear reflectors and/or front diffusing screens.

5 The said light-transmissive pictures may comprise pictures suitably printed on any convenient substrate or film, by any convenient mode of printing. Suitable pictures include the following: photographs, photographic transparencies, and illustrations printed on paper or other light transmissive material (including pictures produced by conventional printing techniques, or by laser printers, or
10 by photo-copiers).

Where desired, the picture support may include a storage means for storing a plurality of different pictures and an associated, controllable selection means for selecting and positioning specific pictures to match given
15 parts of a commentary. In the case of photographic transparencies, a cell may be provided with a sequence of such transparencies on a continuous film which is carried on a controllable film transporter.

Preferably, the panel or mirror and its
20 associated devices are all arranged in a self-contained cabinet. In such an arrangement, the controller preferably includes, in addition, a temperature monitoring device for monitoring the temperature achieved inside the cabinet, and for supplying temperature dependent signals to the
25 controller so as to enable it to control the selection and energisation of further cells or combinations of cells in a manner such as to prevent the attainment of an unsafe temperature within the cabinet.

A convenient arrangement of such a cabinet has
30 the panel or mirror hingedly mounted at one vertical boundary of the cabinet, so that the panel or mirror forms a hinged front door to the cabinet. With such an arrangement, opening the front door provides ready access to the parts of the apparatus enclosed within the cabinet,
35 and for changing the pictures associated with the respective cells.

According to another aspect of the invention, the display device is provided with a microphone for detecting voice signals emitted by an onlooker in response to

questions put to the viewer in the spoken commentary, and the controller is arranged to change the illuminated cell or combination of illuminated cells in dependence upon the voice signals received.

5 Each cell and its associated lamp and picture support may be constituted by (a) a film projector for projecting magnified picture images directly on to the rear surface of the panel or mirror, or (b) a video apparatus and an associated video tape, likewise for projecting
10 images on to the rear surface of the panel or mirror. With such alternative forms of apparatus, it is relatively simple to back-project moving images on to the panel or mirror.

15 Other features of the present invention will appear from a reading of the description that follows hereafter, and from the claims appended at the end of that description.

20 One preferred form of advertising display device (referred to sometimes hereafter as the 'TALKING MIRROR' (trade mark)) and various modifications thereof, all according to the present invention, will now be described by way of example, and with reference to the accompanying diagrammatic drawings.

 In those drawings:-

25 Figures 1(a) and 1(b) show similar front views looking at the viewing (i.e. front) face of the TALKING MIRROR, showing respectively (a) that face when in its passive, totally reflective state, and (b) that face when in one of its active, partly-transmissive, partly-
30 reflective states;

 Figure 2 shows, to a different scale, a pictorial view of the TALKING MIRROR with its front mirror panel swung open to reveal the associated structure disposed behind the mirror panel;

35 Figure 3 shows, again to a different scale, a cross section taken on a vertical plane III-III indicated in the Figure 2;

 Figure 4 shows, again to a different scale and in a vertical cross section similar to that of Figure 3, a

modification of one only of a plurality of cells shown in Figure 3; and

Figure 5 shows a schematic circuit diagram of the principal electric circuits incorporated in the TALKING MIRROR.

5

Referring now to the drawings, the display device there shown comprises a cabinet 10 having a body part 12 arranged for wall-mounting, and a hinged door 14 carried on the left hand side wall 16 of the body part 12. The door comprises a frame 18 in which is carried a door panel in the form of a mirror 20 of the half-silvered kind.

10

Mounted within the upper portion of the cabinet body 12 is an array of back-projectors 22 arranged when appropriately energised to project picture images on to respective corresponding areas of the rear, half-silvered surface of the mirror 20. Those projectors are clustered around a central cell 24 in which a product 26 to be advertised may be displayed. That cell is provided with a halogen lamp 28 for illuminating the displayed product 26, and if desired, with a rear mirror 30 for enhancing the display of the product 26.

15

20

Mounted on a platform 32 in the lower portion of the cabinet body 12 is an electronic controller 34, an audio tape cassette player 36, two photo-electric proximity sensors 38, and electric wiring 40 interconnecting the various electrical components of the display device.

25

In normal operation, the door is maintained locked in its closed position, and is opened to the position shown in the Figure 2 for access and servicing purposes only.

30

Each back-projector 22 comprises an open-fronted cell 42 in which is mounted a halogen lamp 44. The cell is provided at its open front end with a picture holder 46 for receiving and supporting a light-transmissive picture 48 whose image is to be projected on to the rear surface of the mirror 20. The cells 24 and 44 are all constructed of a light-opaque material which prevents light from one cell reaching any other cell. If desired, a light reflecting surface 50 may be provided at the closed rear end of each

35

cell 42, whilst a translucent diffuser screen 52 may be disposed at the open front end of the cell between the lamp 44 and the picture 48.

5 A thermo-sensor 54 mounted in the upper part of the cabinet supplies a temperature dependent signal to the electrical controller 34.

10 As shown in the schematic diagram of Figure 5, the controller 34 has output circuits 34A and 34B for energising the halogen lamps 44 in the respective cells 42, an output circuit 34C for energising the lamp 28 in the central display cell 24, and an output circuit 34D for supplying control signals to the tape cassette player 36.

15 The controller has input circuits 34E for receiving input signals from the two proximity sensors 38, an input circuit 34F for receiving the temperature signal from the thermo-sensor 54, an input circuit 34G for receiving control signals from the cassette player 36, and an input circuit 34H for receiving input signals from a microphone 56 mounted behind the mirror.

20 The controller 34 also incorporates a sequence control device 58 which when activated by a signal from one or both proximity sensors 38 carries out a sequence of operations to cause the TALKING MIRROR to react in a desired manner to the presence of a person standing adjacent the mirror.

25 The sequence control device 58 may include an electric motor driven series of cam-operated switches which are connected in the respective lamp energising and other output circuits of the controller. Thus, on energisation of the electric motor the sequence control device causes first the illumination of the central display cell 24, then the actuation of the cassette player 36 so as to initiate a spoken commentary, and then in succession the illumination of selected cells 42 or selected combinations of cells 42, the sequence of such cells or combinations thereof being coordinated with successive parts of the spoken commentary emitted by the cassette player.

35 The energisation of the selected lamps or combinations of lamps may be automatically dimished or

otherwise modified by the temperature signal received from the thermo-sensor 54, so as to limit the heat generated within those lamps, and thereby to prevent excessive temperatures being reached in the cabinet.

5 Control signals incorporated in the audio tape are (or may be) relayed by the cassette player 36 to the controller 34 via the input circuit 34G, and serve to affect or modify the operation of the sequence control device 58 so as to provide a desired time sequence of
10 illuminated cells or combinations thereof.

 In cases where the spoken commentary asks questions of the person looking into the mirror, the responses of that person are picked up by the microphone 56 and relayed to the controller 34 via the input circuit 34H,
15 so as to effect or modify the operation of the sequence control device 58.

 In an alternative form of electrical controller, the sequence control device may comprise a wholly-static electronic circuit for effecting the same or a similar
20 sequence of cell illumination and coordinated commentary.

 In a modification of the display device described above, the sequence control device 58 comprises an electronic circuit which is arranged to select on a random basis predetermined combinations of cell illumination. In
25 that case, the sequence control device 58 supplies to the cassette player 36 via the output circuit 34D control signals identifying the particular section of the spoken commentary which is to accompany the currently selected illuminated cell or combination of illuminated cells.

30 In another modification of the controller, the sequence control device is activated by control signals provided by the cassette player in response to other control signals incorporated in the tape carrying the spoken commentary.

35 The display device described above may also be modified in that, in one or more of the cells 42 (Figure 4) the picture 48 is replaced by a cassette 60 of pictures and an associated controllable selection means 62 for selecting from the cassette specific pictures in turn, as identified

by signals received at its input circuit 64 from the controller 34. Such picture selection signals may be derived from corresponding picture selection signals included in the spoken commentary tape.

5 The picture selection signals implanted in the commentary tape may be such as to produce at a particular area of the mirror, during a particular section of commentary, a sequence of successive pictures, and such pictures may be changed at a rate and in a manner such as
10 to produce, in effect, moving images. Such moving images could be more easily produced by a miniature film projector substituted in place of the appropriate cell 42, lamp 44 and picture 48. Alternatively, such moving images could be
15 produced by using a small electronic video apparatus having as its input source a suitable video tape and video tape player. In such an alternative display device, the video tape could also incorporate the spoken commentary, thus obviating the need for the audio tape cassette player 36.

 Whereas in the above described display device, a
20 mirror 20 has been used to provide a plain front panel for the cabinet, which on the close approach of a person becomes an active display panel showing in changing parts of the mirror back-projected advertising displays which are accompanied by appropriate commentary, the mirror may be
25 replaced by any equivalent decorative panel which permits a similar change from a passive, decorative (e.g. totally front light reflective) state to an active state in which selected areas thereof exhibit pictures produced by back-projection techniques. For example, the technique for
30 applying the silvering particles to a glass substrate may be used instead to apply some aesthetically attractive paint(s) or dye(s) to a glass substrate, or otherwise to a suitable transparent plastics film or rigid sheet material.

 In a further alternative modification of the
35 apparatus first described above, the individual pictures for the respective cells 48 may be formed as a single composite mask for supporting as a single unit between the array of cells and the rear surface of the mirror 20.

It will be appreciated from the above

description, that a person approaching any one of the display devices described above would see first in the distant decorative panel (e.g. half-silvered mirror) the normal front-lighted appearance of the panel (e.g. reflections of the neighbouring environment). However, on closer approach to the panel, the normal appearance (or reflections) seen in various areas of the panel would be replaced by back-projected picture images, and a voice would be heard speaking a commentary appropriate to the subject matter portrayed in the back-projected images. Those images may be static ones, or they may be moving images, depending on the nature of the projection and picture systems used in the TALKING MIRROR. The panel (or mirror) area or combination of panel (or mirror) areas portraying such images would change periodically in a manner co-ordinated with the subject matter of successive sections of the spoken commentary.

Where the spoken commentary poses questions for response by the person looking into the panel (or mirror), the nature of the response conveyed to the electrical controller may be used by the controller, for example, to determine the next back-projected area or combination of such areas of the panel (or mirror) and the relevant section of spoken commentary.

25

30

52:sp-712j8

35

CLAIMS

1. A display device comprising:
 - (a) a decorative panel or screen;
 - 5 (b) an array of controllable back-projection means disposed behind the panel and arranged when energised to project on to the rear surface of the panel respective predetermined picture images at a level of illumination such that those images can be seen by a person looking at
10 the front surface of the panel in appropriate areas of the panel in place of the appearance normally seen in such areas;
 - (c) an electrical controller for selectively controlling in a predetermined manner the energisations of the
15 respective back-projection means, the controller being arranged such that when activated, a picture image or a combination of picture images can be seen by said person, and such that the picture image or combination of picture images is automatically changed periodically;
 - 20 (d) an audio tape cassette player arranged when activated to emit a spoken commentary coordinated with the sequence of back-projected images or combinations thereof; and
 - (e) a proximity sensor for sensing the presence of a person adjacent the panel and thereupon causing activation
25 of the electrical controller and directly or indirectly of the cassette player, thereby to present to such person successive picture images or combinations thereof and simultaneously a spoken commentary coordinated with the respective images or combinations of images.
- 30 2. A display device according to claim 1, wherein the proximity sensor comprises a photo-responsive sensor arranged to respond to light reaching it through the panel.
3. A display device according to claim 1 or 2, wherein the electrical controller, the cassette player, and the
35 proximity sensor are all disposed behind and obscured from view by the panel.
4. A display device according to any preceding claim, wherein each back-projection means comprises an open-fronted cell having its open front adjacent the rear

surface of the panel, a controllable electric lamp disposed in said cell, a picture support carried by the cell at its open front for supporting there a light-transmissive picture, the cell being constructed in such a manner and of such a material that light from said lamp cannot reach any other cell.

5
10
15
20
25
30
35
40
45
50
55
60
65
70
75
80
85
90
95
100
105
110
115
120
125
130
135
140
145
150
155
160
165
170
175
180
185
190
195
200
205
210
215
220
225
230
235
240
245
250
255
260
265
270
275
280
285
290
295
300
305
310
315
320
325
330
335
340
345
350
355
360
365
370
375
380
385
390
395
400
405
410
415
420
425
430
435
440
445
450
455
460
465
470
475
480
485
490
495
500
505
510
515
520
525
530
535
540
545
550
555
560
565
570
575
580
585
590
595
600
605
610
615
620
625
630
635
640
645
650
655
660
665
670
675
680
685
690
695
700
705
710
715
720
725
730
735
740
745
750
755
760
765
770
775
780
785
790
795
800
805
810
815
820
825
830
835
840
845
850
855
860
865
870
875
880
885
890
895
900
905
910
915
920
925
930
935
940
945
950
955
960
965
970
975
980
985
990
995

5. A display device according to claim 4, wherein the cell is provided with a picture store in which a plurality of pictures may be held, and a controllable picture selection means for selecting a specific picture from the store and placing it in position in the open front of the cell in response to and in accordance with a picture identifying signal supplied to it.

6. A display device according to claim 5, wherein the picture store comprises a film cassette arranged to store a roll of photographic transparencies.

7. A display device according to claim 5 or 6, wherein said audio cassette player is arranged to relay to the picture selection means, as said picture identifying signals, control signals incorporated in a spoken commentary tape, either directly or indirectly through said electrical controller.

8. A display device according to any one of the claims 1 to 6, wherein the electrical controller is arranged to select a next back-illuminated panel area or combination of such areas on a random basis, and to supply to the audio cassette player signals identifying the sections of the spoken commentary which are to be played so as to match the selected panel area or areas.

9. A display device according to any preceding claim, wherein each back-projection means comprises a film projector arranged to project transparency images on to the rear surface of the panel.

10. A display device according to any one of the claims 1 to 8, wherein each back-projection means comprises an electronic video projection apparatus arranged to project video images on to the rear surface of the panel under the control of an associated video tape.

11. A display device according to any preceding claim,

wherein the panel, and all its associated components are contained in a cabinet of which the said panel forms the front panel of the cabinet.

12. A display device according to claim 11, wherein said
5 front panel is hinged to form a cabinet access door.

13. A display device according to claim 11 or 12,
including a temperature responsive sensor mounted in an
upper part of the cabinet and arranged to supply to the
electrical controller a temperature signal, and wherein
10 said controller is arranged to modify the sequence or
magnitude of energisation of the respective back-projection
means in a manner such as to prevent the temperature in the
cabinet reaching an unsafe level.

14. A display device according to any preceding claim,
15 wherein the decorative panel comprises a half-silvered
mirror.

15. A display device according to any one of the claims 1
to 13, wherein the decorative panel comprises a normally
opaque panel (i.e. when front lit) which has been produced
20 by treating a transparent substrate or film with one or
more paints or dyes in a manner similar to that employed in
producing a half-silvered mirror, so that back-projected
images may be visible to a person adjacent the front of the
panel.

25 16. A display device according to any one of the claims 1
to 13, wherein the decorative panel comprises textile
fabric screen.

17. A display device according to any one of the claims 1
to 13, wherein the panel comprises a tinted glass panel.

30 18. A display device substantially as hereinbefore
described with reference to and as illustrated by any
single Figure or group of associated Figures of the
accompanying diagrammatic drawings.

19. A display apparatus comprising any operable
35 combination of the various features disclosed in this
specification, other than a combination included in any
preceding claim.

52:sp-712j8