

(19) World Intellectual Property Organization  
International Bureau



(43) International Publication Date  
18 November 2010 (18.11.2010)

(10) International Publication Number  
**WO 2010/132331 A2**

(51) International Patent Classification:

*A61K 9/20* (2006.01)      *A61K 9/28* (2006.01)  
*A61K 9/16* (2006.01)      *A61B 1/05* (2006.01)  
*A61K 9/24* (2006.01)

(21) International Application Number:

PCT/US2010/034186

(22) International Filing Date:

10 May 2010 (10.05.2010)

(25) Filing Language:

English

(26) Publication Language:

English

(30) Priority Data:

61/177,611      12 May 2009 (12.05.2009)      US

(71) Applicant (for all designated States except US): **PROTEUS BIOMEDICAL, INC.** [US/US]; 2600 Bridge Parkway, Suite 101, Redwood City, CA 94065 (US).

(72) Inventors; and

(75) Inventors/Applicants (for US only): **DUCK, Robert** [US/US]; 1800 Washington Street, #118, San Francisco, CA 94109 (US). **SAVAGE, George** [US/US]; 1180 Westridge Drive, Portola Valley, CA 94028 (US). **JOHNSON, Patricia** [US/US]; 3354 Ramona Street, Palo Alto, CA 94306 (US). **ZDEBLICK, Mark** [US/US]; 300 La Mesa Drive, Portola Valley, CA 94028 (US). **COSTELLO, Benedict** [GB/US]; 1316 Josephine Street, Berkeley, CA 94703 (US). **AU-YEUNG, Kit Yee** [CN/US]; 250 King Street, Apt. 1510, San Francisco, CA 94107 (US). **ROBERTSON, Timothy** [US/US]; 2719 Sequoia Way, Belmont, CA 94002 (US). **HAFEZI,**

**Hooman** [US/US]; 64 Eddystone Court, Redwood City, CA 94065 (US).

(74) Agent: **FIELD, Bret**; Bozicevic Field & Francis LLP., 1900 University Avenue, Suite 200, East Palo Alto, CA 94303 (US).

(81) Designated States (unless otherwise indicated, for every kind of national protection available): AE, AG, AL, AM, AO, AT, AU, AZ, BA, BB, BG, BH, BR, BW, BY, BZ, CA, CH, CL, CN, CO, CR, CU, CZ, DE, DK, DM, DO, DZ, EC, EE, EG, ES, FI, GB, GD, GE, GH, GM, GT, HN, HR, HU, ID, IL, IN, IS, JP, KE, KG, KM, KN, KP, KR, KZ, LA, LC, LK, LR, LS, LT, LU, LY, MA, MD, ME, MG, MK, MN, MW, MX, MY, MZ, NA, NG, NI, NO, NZ, OM, PE, PG, PH, PL, PT, RO, RS, RU, SC, SD, SE, SG, SK, SL, SM, ST, SV, SY, TH, TJ, TM, TN, TR, TT, TZ, UA, UG, US, UZ, VC, VN, ZA, ZM, ZW.

(84) Designated States (unless otherwise indicated, for every kind of regional protection available): ARIPO (BW, GH, GM, KE, LR, LS, MW, MZ, NA, SD, SL, SZ, TZ, UG, ZM, ZW), Eurasian (AM, AZ, BY, KG, KZ, MD, RU, TJ, TM), European (AL, AT, BE, BG, CH, CY, CZ, DE, DK, EE, ES, FI, FR, GB, GR, HR, HU, IE, IS, IT, LT, LU, LV, MC, MK, MT, NL, NO, PL, PT, RO, SE, SI, SK, SM, TR), OAPI (BF, BJ, CF, CG, CI, CM, GA, GN, GQ, GW, ML, MR, NE, SN, TD, TG).

Published:

— without international search report and to be republished upon receipt of that report (Rule 48.2(g))

(54) Title: INGESTIBLE EVENT MARKERS COMPRISING AN INGESTIBLE COMPONENT

(57) Abstract: Ingestible event markers comprising an identifier and an ingestible component are provided. The ingestible component may vary, where ingestible components of interest include osmotic ingestible components, liquid capsules, tablets, multi-layered ingestible component and multi-compartment ingestible components. In some instances, the identifier is mechanically stably associated with the ingestible component. Also provided are systems that include the ingestible event markers, as well as methods of using the ingestible event markers.



WO 2010/132331 A2



## SUMMARY

Event markers, e.g., ingestible event markers comprising an ingestible component are provided. The ingestible component may vary, where ingestible components of interest include osmotic ingestible components, liquid capsules, tablets, multi-layered ingestible component and multi-compartment ingestible components. In some instances, the ingestible event marker is mechanically stably associated with the ingestible component. Also provided are systems that include the ingestible event markers, as well as methods of using the ingestible event markers.

10

## BRIEF DESCRIPTION OF THE FIGURES

FIGS. 1A and 1B provide views of various configurations according to different aspects of the invention.

FIGS. 2A to 2D provide views of different osmotic capsule configurations.

15 FIG. 3 provides a view of an ingestible event marker associated with an osmotic component of an osmotic capsule.

FIG. 4 provides a view of an ingestible event marker associated with the outer surface an osmotic capsule.

20 FIG. 5 provides a view of multiple ingestible event markers integrated in the semipermeable wall of an osmotic capsule.

FIG. 6 provides a view of an ingestible event marker where different potential locations are shown on an osmotic capsule.

FIG. 7 provides a view of a coated ingestible event marker present inside of a liquid capsule.

25 FIG. 8 provides a view of a vesicle-encased ingestible event marker is present inside of a liquid capsule.

FIG. 9 provides a view of an ingestible event marker present inside of a sealed compartment inside of a liquid capsule.

30 FIGS. 10A to 10B illustrate a liquid capsule (as well as a method for its fabrication) in which an ingestible event marker is integrated with a capsule component of the liquid capsule.

FIG. 11 provides a view of an ingestible event marker integrated into a lid that associates with a container to encase a tablet.

FIG. 12 provides a view of an ingestible event marker integrated into a non-encasing band that associates with a tablet.

FIGS. 13A and 13B provide a view of an ingestible event marker where an identifier is press-fit into a receiving element of a tablet.

5

### DETAILED DESCRIPTION

Event markers, e.g., ingestible event markers (“IEMs”), sometimes referred to herein as “identifiers”, and associated ingestible component are provided. The ingestible component may vary, where ingestible components of interest include osmotic ingestible components, liquid capsules, tablets, multi-layered ingestible component and multi-compartment ingestible components. In some instances, the ingestible event marker is mechanically stably associated with the ingestible component. Also provided are systems that include the ingestible event markers, as well as methods of using the ingestible event markers.

15

#### INGESTIBLE EVENT MARKERS

An ingestible event marker (IEM) is a device that is dimensioned to be ingestible and includes an identifier circuitry component and, optionally, an amplifier or current path extender.

20

To illustrate, various aspects of the IEM may comprise a support, a control circuit physically associated with the support to control the IEM, a first electrochemical material physically associated with the support and electrically coupled to the control circuit, a second electrochemical material electrically coupled to the control circuit and physically associated with the support at a location different from the location of the first material.

25

Upon ingestion, the IEM contacts a conducting fluid, e.g., stomach fluid. The conducting fluid activates the IEM and the first and second electrochemical materials provide a voltage potential difference. In various aspects, the control circuit controls the conductance through logic that alters the overall impedance of the system. The control circuit, for example, may be electrically coupled to a clock. The clock may provide a clock cycle to the control circuit. Based upon the

30

programmed characteristics of the control circuit, when a set number of clock cycles have passed, the control circuit alters the conductance characteristics between electrochemical materials. This cycle may be repeated and thereby the control circuit may produce a unique current signature characteristic, sometimes  
5 referred to herein as a "current signature". The control circuit may also be electrically coupled to a memory. Both the clock and the memory may be powered by the voltage potential created between the materials when in contact with a conducting fluid.

Thus, in some instances, the two dissimilar electrochemical materials  
10 serve as a cathode and an anode. When the two dissimilar electrochemical materials come in contact with the body fluid, such as stomach fluid, a potential difference (voltage) is generated between the cathode and the anode as a result of the respective oxidation and reduction reactions occurring at the two dissimilar electrochemical materials. The dissimilar electrochemical materials making up  
15 the electrochemical materials can be made of any two materials appropriate to the environment in which the IEM circuitry component will be operating. The active materials are any pair of materials with different electrochemical potentials. The electrochemical material materials may be chosen to provide for a voltage upon contact with the target physiological site. Where desired, the voltage  
20 provided by the two dissimilar electrochemical materials upon contact of the metals of the power source with the target physiological site is 0.001 V or higher, including 0.01 V or higher, such as 0.1 V or higher, e.g., 0.3 V or higher, including 0.5 volts or higher, and including 1.0 volts or higher, where in certain aspects, the voltage ranges from about 0.001 to about 10 volts, such as from about 0.01 to  
25 about 10 V.

Anode materials of interest include, but are not limited to: magnesium, zinc, sodium, lithium, iron and alloys thereof, e.g., Al and Zn alloys of Mg, which may or may not be intercalated with a variety of materials such, as graphite with Li, K, Ca, Na, Mg, and the like. Cathode materials of interest include, but are not  
30 limited to, copper salts, such as copper salts of iodide, chloride, bromide, sulfate, formate,  $\text{Fe}^{3+}$  salts, e.g., orthophosphate, pyrophosphate, etc. One or both of the metals may be doped with a non-metal, for example to enhance the voltage output of the battery. Non-metals that may be used as doping agents in certain aspects include, but are not limited to: sulfur, iodine and the like. In certain

aspects, the electrode materials are cuprous iodine (CuI) or cuprous chloride (CuCl) as the anode and magnesium (Mg) metal or magnesium alloy as the cathode. Aspects of the present invention use electrode materials that are not harmful to the human body.

5

With respect to current signatures, the current signatures may distinguish one class of highly reliable event marker from other types or may be universally unique, such as where the current signature is analogous to a human fingerprint which is distinct from any other fingerprint of any other individual and therefore uniquely identifies an individual on a universal level. In various aspects, the control circuit may generate a variety of different types of communications, including but not limited to: RF signals, magnetic signals, conductive (near field) signals, acoustic signals, etc.

In various aspects, the IEM may further comprise a membrane which, for example, produces a virtual dipole length between the pair of transmission elements that is larger than the actual dipole length. In addition to controlling the magnitude of the current path between the materials, a membrane (sometimes referred to herein as “amplifier” or “skirt”) is used to increase the “length” of the current path and, hence, act to boost the conductance path, as disclosed in the U.S. Patent Application Serial No. 12/238,345 entitled, “In-Body Device with Virtual Dipole Signal Amplification” filed September 25, 2008, and in the U.S. Patent Application Serial No. 12/564,017 entitled, “Communication System with Partial Power Source” filed September 21, 2009 the entire content of which are incorporated herein by reference.

Receivers, sometimes referred to herein as a “detector” may detect the communication, e.g., current. Receivers may not require any additional cable or hard wire connection between the device and a receiver of the communication, sometimes referred to herein as a detector.

In addition to the IEM, aspects also include an ingestible component with which the IEM is stably associated in some manner. By “stably associated” is meant that the IEM and the ingestible component, e.g., a vehicle, do not separate from each other, at least until administered to the subject in need thereof, e.g., by ingestion. As the IEMs are dimensioned to be ingestible, they are sized so that they can be placed in a mammalian, e.g., human or animal, mouth and

swallowed. In some instances, IEMs of the invention have a longest dimension that is 30 mm or less, such as 20 mm or less, including 5 mm or less.

Various aspects of ingestible event markers of interest are described in PCT application serial no. PCT/US2006/016370 published as WO/2006/116718; 5 PCT application serial no. PCT/US2007/082563 published as WO/2008/052136; PCT application serial no. PCT/US2007/024225 published as WO/2008/063626; PCT application serial no. PCT/US2007/022257 published as WO/2008/066617; PCT application serial no. PCT/US2008/052845 published as WO/2008/095183; PCT application serial no. PCT/US2008/053999 published as WO/2008/101107; 10 PCT application serial no. PCT/US2008/056296 published as WO/2008/112577; PCT application serial no. PCT/US2008/056299 published as WO/2008/112578; and PCT application serial no. PCT/US2008/077753 published as WO2009/042812; the disclosures of which are herein incorporated by reference.

In certain aspects, the ingestible event markers are disrupted upon 15 administration to a subject. As such, in certain aspects, the compositions are physically broken, e.g., dissolved, degraded, eroded, etc., following delivery to a body, e.g., via ingestion, injection, etc. The compositions of these aspects are distinguished from devices that are configured to be ingested and survive transit through the gastrointestinal tract substantially, if not completely, intact.

20 IEMs may be fabricated using any convenient protocol. IEM fabrication protocols of interest include, but are not limited to, those described in PCT application serial no. PCT/US2006/016370 published as WO/2006/116718; PCT application serial no. PCT/US2007/082563 published as WO/2008/052136; PCT application serial no. PCT/US2007/024225 published as WO/2008/063626; PCT 25 application serial no. PCT/US2007/022257 published as WO/2008/066617; PCT application serial no. PCT/US2008/052845 published as WO/2008/095183; PCT application serial no. PCT/US2008/053999 published as WO/2008/101107; PCT application serial no. PCT/US2008/056296 published as WO/2008/112577; PCT application serial no. PCT/US2008/056299 published as WO/2008/112578; and 30 PCT application serial no. PCT/US2008/077753; the disclosures of which are herein incorporated by reference.

FIGS. 1A provides a view of an aspect of an IEM according to the invention which has a membrane that extends beyond the outer edges of the signal transmission elements to provide a virtual dipole having a length that is

longer than the actual dipole between the signal transmission elements. As shown in FIG. 1A, IEM 1 includes integrated circuit 2, having a first electrochemical material 4 (which may comprise two distinct material layers) and a second electrochemical material 6. Also shown is disc shaped membrane 5.

5 FIG. 1B provides an overhead view of the IEM shown in FIG. 1A, showing the disc shape of first electrochemical material 4 and the positioning of the first electrochemical material in the center of disc shaped membrane 5. The distance that the edge of the membrane may extend beyond the edge of electrodes may vary, and in certain aspects is 0.05 mm or more, e.g., 0.1 mm or more, including

10 1.0 mm or more, such as 5.0 mm or more and including 10 mm or more, where the distance may not exceed 100 mm in certain aspects.

As can be seen in the aspect depicted in FIGS. 1A to 1B, the first and second electrochemical materials may have any convenient shape, e.g., square, disc, etc. The disc shaped membrane 5 is a planar disc structure, where the

15 edge of the membrane extends beyond the edge of the planar the first and second electrochemical materials. In the depicted aspect, the radius of the membrane is longer than the radius of the first and second electrochemical materials, e.g., by 1mm or more, such as by 10 mm or more.

Membranes may have "two-dimensional" or "three-dimensional" configurations, as desired. Membrane configurations of interest are further

20 described in PCT application serial no. US2008/077753 published as WO2009/042812, as well as United States provisional application serial nos. 61/142,849 and 61/173,511; the disclosures of which are herein incorporated by reference.

The membrane may be fabricated from a number of different materials, where the membrane may be made of a single material or be a composite of two or more different types of materials, as developed in greater detail below. In certain instances, the membrane will have a mechanical strength sufficient to withstand the mechanical forces typical of the gastrointestinal (GI) tract without

25 folding onto itself and losing its shape. This desired mechanical strength may be chosen to last for at least the duration of the communication, which may be 1 second or longer, such as at least 1 minute or longer, up to 6 hours or longer. In certain aspects, the desired mechanical strength is selected to last for a period of time ranging from 1 to 30 minutes. The desired mechanical strength can be

30



achieved by proper selection of polymer and/or fillers, or mechanical design (e.g., lamination of multiple layers, or curvature of the amplifier surface) to increase the mechanical strength of the final structure.

5 Membranes of the invention are ones that are electrically insulating. As such, the materials from which the membranes are fabricated are electrically insulating materials. A given material is electrically insulating if it has a resistivity that is two times or greater than the medium in which the device operates, e.g., stomach fluid, such as ten times or greater, including 100 times or greater than the medium in which the device operates.

10

### *Ingestible Component*

As summarized above, various aspects of the invention include one or more IEMs physically associated with an ingestible component. The ingestible components are compositions that are ingestible. Solid ingestible component configuration formats include tablet and capsule configurations. While the ingestible component may have a solid configuration, the solid configuration may include a liquid component, such as is present in a liquid capsule. In some instances, the ingestible component is configured to impart a controlled release profile to an active agent that is associated with the IEM. Ingestible components of interest can be found in Remington's Pharmaceutical Sciences, Mace Publishing Company, Philadelphia, Pa., 17th ed. (1985). Three types of ingestible components of interest are: 1) osmotic ingestible components; 2) liquid capsules; and 3) ingestible components in which the IEM is mechanically stably associated with the ingestible component. Each of these configurations of interest is now described in greater detail.

### Osmotic Ingestible Component

30 Aspects of the invention include IEMs in which one or more IEMs are stably associated with an ingestible component that is an osmotic ingestible component. Of interest are osmotic ingestible components that exhibit a controlled release profile, such as an extended release profile or other release profile, as desired. Osmotic ingestible components are ingestible components

that include an osmotic member. By osmotic member is meant a component that that is fabricated from a material which absorbs, i.e., imbibes, liquid by osmosis and in doing so, either alone or in conjunction with other components of the IEM, at least modulates release of an active agent from the IEM. Osmotic ingestible  
5 components may have a variety of different configurations, including capsule configurations, tablet configurations, etc. In certain instances, osmotic ingestible components include a semipermeable layer (for example a coating or membrane), an osmotic member, and one or more stably associated IEMs. Semipermeable layers and osmotic members are further described below in  
10 conjunction with osmotic capsule aspects. However, while osmotic capsules are described in greater detail below, of interest are all osmotic ingestible components that include an osmotic member, a semipermeable layer and an IEM.

Osmotic ingestible components of interest include, but are not limited to:  
15 osmotic capsules. FIG. 2A shows an example of an osmotic ingestible component that has a capsule configuration. In FIG. 2A, osmotic capsule 10, is seen in closed view, comprising a body 11, a wall 12 and passageway 13. Wall 12 surrounds and forms an internal space, not seen in FIG. 2A. Osmotic capsule 10 has a first end 9 with passageway 13 and a second end 8.

20 In FIG. 2B, osmotic capsule 10 is shown having body 11, wall 12 that surrounds and forms internal space 14. Wall 12 comprises passageway, i.e., orifice, 13 that connects internal space 14 with the exterior environment of the osmotic capsule 10. Internal space 14 holds and stores a capsule comprising a body section 16 and a cap section 17. These sections may be fabricated from  
25 any convenient material, such as hydroxypropylmethylcellulose (HPMC). The body section 16 is a component receiving section that is filled with an active agent composition 19 which may include a pharmaceutically acceptable carrier, 18. The pharmaceutically acceptable carrier 18 can be initially dry, or initially wet. An osmotic member 21, such as an expandable hydrophilic polymer as  
30 described in greater detail below, is present in the open end of body 16 and closed by sliding cap 17 over body section 16. In those instances where body 16 comprises a dry active agent 19 composition, a solution or a suspension is formed in the capsule by fluid being imbibed from the environment into the capsule for mixing with the active agent in situ. As shown in FIG. 2B, the osmotic

capsule 10 is composed of two sections fitted together by slipping or telescoping the cap section over the body section. This configuration provides a closed capsule in which the capsule wall surrounds and encapsulates the active agent composition 19. The capsule composed of two sections defines a hard capsule.

5 Osmotic capsule 10 comprises an osmotic member 21 that expands in the presence of imbibed aqueous and biological fluids. Body 16 comprising osmotic member 21 is closed by cap 17, to provide a closed capsule. Osmotic member 21 provides an expandable push driving force that acts to deliver the active agent 19 from the osmotic capsule 10. Osmotic member 21 exhibits fluid imbibing and/or absorbing properties. Osmotic member 21 may include a hydrophilic polymer that can interact with water and aqueous biological fluids and then swell or expand. The hydrophilic polymers are known also as osmopolymers, osmogels and hydrogels, and they exhibit a concentration gradient across wall 12, whereby they imbibe fluid into osmotic capsule 10. Hydrophilic polymers of interest include, but are not limited to: poly(alkylene oxide) of 10,000 to 10,000,000 weight-average molecular weight including poly(ethylene oxide), and an alkali carboxymethylcellulose of 10,000 to 6,000,000 weight average molecular weight including sodium carboxymethylcellulose. Osmotic member 21 may include 10 mg to 425 mg of osmopolymer. Osmotic member 21 may include 15 1 mg to 50 mg of a poly(cellulose) of a member selected from the group consisting of hydroxyethylcellulose, hydroxypropylcellulose, hydroxypropylmethylcellulose, and hydroxypropylbutylcellulose. Osmotic member 21 may include 0.5 mg to 175 mg of an osmotically effective solute (known also as osmotic solute and osmagent) that imbibes fluid through wall 12 into osmotic capsule 10. The osmotically effective solutes may be selected from the group consisting of a salt, acid, amine, ester and carbohydrate. Osmagents of interest include, but are not limited to: magnesium sulfate, magnesium chloride, potassium sulfate, sodium sulfate, lithium sulfate, potassium acid phosphate, mannitol, urea, inositol, magnesium succinate, tartaric acid, sodium chloride, potassium chloride, and carbohydrates such as raffinose, sucrose, 20 glucose, lactose, and sorbitol. Osmotic member 21 may also include 0 wt % to 3.5 wt % of a colorant, such as ferric oxide.

Osmotic capsule 10 includes a wall 12 that surrounds the internal capsule produced by 16 and 17. Wall 12 may be fabricated from a composition

permeable to the passage of fluid, aqueous and biological fluid, present in environment of use. In addition, wall 12 is substantially impermeable to the passage of active agent composition 19. Wall 12 is nontoxic, and it maintains its physical and chemical integrity during the active agent delivery from the osmotic capsule 10. Materials of interest for forming wall 12 include, but are not limited to: semipermeable polymers, semipermeable homopolymers, semipermeable copolymers, and semipermeable terpolymers. Polymers of interest include cellulose esters, cellulose ethers, and cellulose ester-esters. These cellulosic polymers may have a degree of substitution, D.S., on their anhydroglucose unit from greater than 0 up to 3 inclusive. By degree of substitution is meant the average number of hydroxyl groups originally present on the anhydroglucose unit that are replaced by a substituting group, or converted into another group. The anhydroglucose unit can be partially or completely substituted with groups such as acyl, alkanoyl, alkenoyl, aroyl, alkyl, alkoxy, halogen, carboalkyl, alkylcarbamate, alkylcarbonate, alkylsulfonate, alkylsulfamate, and semipermeable polymer forming groups.

The semipermeable materials may include a member selected from the group consisting of cellulose acylate, cellulose diacylate, cellulose triacetate, cellulose acetate, cellulose diacetate, cellulose triacetate, mono-, di- and tri-cellulose alkanylates, mono-, di-, and tri-alkenylates, mono-, di-, and tri-aroylates, and the like. Polymers of interest include cellulose acetates having a D.S. of 1.8 to 2.3 and an acetyl content of 32 to 39.9%; cellulose diacetates having a D.S. of 1 to 2 and an acetyl content of 21 to 35%; cellulose triacetates having a D.S. of 2 to 3 and an acetyl content of 34 to 44.8%; and the like. More specific cellulosic polymers of interest include cellulose propionates having a D.S. of 1.8 and a propionyl content of 38.5%; cellulose acetate propionates having an acetyl content of 1.5 to 7% and an acetyl content of 39 to 42%; cellulose acetate propionates having an acetyl content of 2.5 to 3%, an average propionyl content of 39.2 to 45% and a hydroxyl content of 2.8 to 5.4%; cellulose acetate butyrates having a D.S. of 1.8, an acetyl content of 13 to 15%, and a butyryl content of 34 to 39%; cellulose acetate butyrates having an acetyl content of 2 to 29.5%, a butyryl content of 17 to 53%, and a hydroxyl content of 0.5 to 4.7%; cellulose triacylates having a D.S. of 2.9 to 3 such as cellulose trivalerate, cellulose trilaurate, cellulose tripalmitate, cellulose trioctanoate, and cellulose tripropionate;

cellulose diesters having a D.S. of 2.2 to 2.6 such as cellulose disuccinate, cellulose dipalmitate, cellulose dioctanoate, cellulose dicarpylate and the like; mixed cellulose esters such as cellulose acetate valerate, cellulose acetate succinate, cellulose propionate succinate, cellulose acetate octanoate, cellulose valerate palmitate, cellulose acetate heptonate, cellulose valerate palmitate, cellulose acetate heptonate, and the like.

Additional semipermeable polymers include cellulose acetaldehyde dimethyl acetate; cellulose acetate ethylcarbonate; cellulose acetate methylcarbamate; cellulose dimethylaminoacetate; semipermeable polyamides; semipermeable polyurethanes; semipermeable sulfonated polystyrenes; cross-linked, selectively semipermeable polymers formed by the coprecipitation of a polyanion and a polycation; semipermeable polystyrene derivatives; semipermeable poly(sodium styrenesulfonate); semipermeable poly(vinylbenzyltrimethyl)ammonium chloride; semipermeable polymers exhibiting a fluid permeability of 10 to 10 (cc.mil/cm.hr.atm) expressed as per atmosphere of hydrostatic or osmotic pressure difference across a semipermeable wall.

FIG. 2C illustrates another osmotic capsule 10 configuration of interest. In FIG. 2C, osmotic capsule 10 includes a body 11, comprising wall 12 with a passageway 13. Wall 12 surrounds and defines internal compartment 14 housing internal capsule 20. Internal capsule 20 in its final manufacture comprises a one piece capsule that distinguishes capsule 20 from the two piece capsule presented above in FIG. 2B. Capsule 20 comprises active agent composition 19. Capsule 20 also includes osmotic member 21, as presented above. Capsule 20 of FIG. 2C includes a movable piston 22. The movable piston 22 moves or slides in response to pressure generated inside capsule 20. The piston is positioned between and in contacting relation with the active agent composition 19 and osmotic member 21. The piston serves to reduce diffusion and/or migration between the active agent composition and the osmotic member, thereby maintaining the concentration of the active agent composition. In addition, the piston prevents interaction between the active agent composition and the osmotic member 21.

Osmotic capsule 10 in operation imbibes fluid through wall 12 causing osmotic member 21 to expand and apply pressure against piston 22. This

applied pressure moves piston 22 towards passageway 13 whereby the active agent composition 19 present in internal space 14 is pushed through passageway 13 into the environment of use. Examples of materials for manufacturing movable piston 22 include a member selected from the group consisting of a wax, petroleum wax, an ester of a high molecular weight fatty acid with a high molecular weight alcohol, a piston formed of an olefin polymer, a condensation polymer, rubber, organosilicon, high density polyethylene, high density polypropylene, and piston forming materials impermeable to fluid.

FIG. 2D illustrates another osmotic capsule 10 configuration of interest. In FIG. 2D, osmotic capsule 10 includes lead end 9, trailing end 8, capsule cap 17, active agent composition 19 in capsule body 16, osmotic member 21 in capsule body 16 closed by capsule cap 17. The components comprising FIG. 2D are as described above. In FIG. 2D, osmotic capsule 10 comprises wall 12 made from an injection-moldable composition by an injection-molding techniques. Injection-moldable compositions provided for injection-molding into wall 12 comprise a thermoplastic polymer, or the compositions comprise a mixture of thermoplastic polymers and optional injection-molding ingredients. The thermoplastic polymers that can be used for the present purpose comprise polymers that have a low softening point, for example, below 200°C, such as within the range of 40°C to 180°C. The polymers may be synthetic resins, for example, linear polycondensation resins, condensation polymerized resins, addition polymerized resins, such as polyamides, resins obtained from diepoxides and primary alkanolamines, resins of glycerine and phthalic anhydrides, polymethane, polyvinyl resins, polymer resins with end-positions free or esterified carboxyl or carboxamide groups, for example with acrylic acid, acrylic amide, or acrylic acid esters, polycaprolactone, and its copolymers with dilactide, diglycolide, valerolactone and decalactone, a resin composition comprising polycaprolactone and polyalkylene oxide, and a resin composition comprising polycaprolactone, a polyalkylene oxide such as polyethylene oxide, poly(cellulose) such as poly((hydroxypropyl)methylcellulose), poly(hydroxyethylmethylcellulose), poly(hydroxyethylcellulose), and poly(hydroxypropylcellulose). The membrane forming composition can comprises optical membrane-forming ingredients such as polyethylene glycol, talcum, polyvinylalcohol, lactose, or polyvinyl pyrrolidone. The compositions for forming an injection-molding polymer composition can

comprise 100% thermoplastic polymer. The composition in another aspect comprises 10% to 99% of a thermoplastic polymer and 1% to 70% of a different polymer with the total equal to 100%. Also of interest is a thermoplastic polymer composition comprising 1% to 98% of a first thermoplastic polymer, 1% to 90% of a different, second polymer and 1% to 90% of a different, third polymer with all polymers equal to 100%. Compositions of interest include a composition of 20% to 90% of thermoplastic polycaprolactone and 10% to 80% of poly(alkylene oxide); a composition comprising 20% to 90% of poly(alkylene oxide); a composition comprising 20% to 90% polycaprolactone and 10% to 60% of poly(ethylene oxide) with the ingredients equal to 100%; a composition comprising of 10% to 97% polycaprolactone, 10% to 97% poly(alkylene oxide), and 1% to 97% of poly(ethylene glycol) with all ingredients equal to 100%; a composition comprising 20% to 90% polycaprolactone and 10% to 80% of polyethylene glycol 40 stearate, with all ingredients equal to 100%; and a composition comprising 1% to 90% polycaprolactone, 1% to 90% poly(ethylene oxide), 1% to 90% poly(hydroxypropylcellulose) and 1% to 90% poly(ethylene glycol) with all ingredients equal to 100%. The percent, expressed is weight percent, wt %.

The expression "passageway" as used herein refers to a structure useful for delivery of active agent from the interior of the osmotic capsule to the outside environment of the osmotic capsule. The expression includes passage way, aperture, hole, bore, pore and the like through the semipermeable wall. The passageway can be formed by mechanical drilling, laser drilling, or by eroding an erodible element, such as a gelatin plug, salt plug, a pressed glucose plug, to yield the orifice, when the dosage form is in the environment of use. In an aspect, the orifice in wall 12 is formed in the environment of use in response to the hydrostatic pressure generated in osmotic capsule 10. In another aspect, the osmotic capsule 10 can be manufactured with two or more orifices in spaced-class relation for delivering active agent 19. The passageway 13 can be formed by mechanical rupturing of wall 12.

Where the ingestible component is an osmotic capsule, the IEM may be stably associated with a variety of different components of the osmotic capsule, as desired. In some instances, the IEM may be associated with the osmotic member in some manner. For example, the IEM may be positioned within the

osmotic member. Alternatively, the IEM may be associated with or completely replace the piston 22 shown in FIG. 2C. An example of such as osmotic capsule is shown in FIG. 3. In FIG. 3, osmotic capsule 10 includes hard-capsule component 31, which may be made from any convenient material, such as hydroxypropylmethylcellulose (HPMC). Hard-capsule component 31 is configured with as a partial capsule in the aspect shown in FIG. 3, and together with semipermeable wall 12 defines an inner space 14. Also shown is osmotic member 21. In the aspect shown in FIG. 3, IEM 32 is configured as a barrier that separates the osmotic member 21 and the active agent composition 19. Where the IEM 32 serves as a barrier separating the osmotic member 21 from the active agent composition 19, the IEM membrane 33 may be dimensioned to conform to the inner walls of the hard-capsule component 31 and therefore serve as the barrier. Where the IEM is present inside the capsule, the hard-capsule component 31 may include, e.g., form, one or more holes 34 and 35 positioned at various locations to enhance communication from the IEM to the outside of the capsule, e.g., via conductive transmission. These one or more holes may be positioned at any convenient location in the wall. Optionally, the IEM 32 may be associated with a micro-environment member 36 which controls the micro-environment of the IEM. For example, micro-environment member 36 may be a dried conductive medium layer (for example a salt layer) that surrounds the IEM 32, and upon wetting provides for a defined conductive medium environment for the IEM. Details regarding micro-environment members and materials that may be employed for the same are further provided in PCT application serial no. PCT/US2007/082563 published as WO 2008/052136; the disclosure of which is herein incorporated by reference. In fabricating the osmotic capsule shown in FIG. 3, the capsule structure may be first produced using any convenient protocol and then filled with the active agent composition, e.g., by introducing the active agent composition into internal space 14 through passageway 13. As indicated above, the active agent layer may be a liquid or solid, such as a powder. In those instances where the active agent composition is a solid, such as a powder, a layered active agent composition may be positioned in the capsule, with two or more layers of differing active agent compositions, as desired. In other instances, the hard-capsule component may be filled with the active agent composition and sealed with the osmotic member 21. The resultant structure



may then be encased in the semipermeable wall 12 and the passageway 13 produced, for example by laser drilling.

Instead of being present inside of the capsule, the IEM may be stably associated with an outer location of the capsule. An example of such a configuration is shown in FIG. 4. In FIG. 4, osmotic capsule 10 includes hard capsule component 31, osmotic member 21, semipermeable wall 12, passageway 13 and active agent composition 19, as described above. Also shown is IEM 32 stably associated with the outer surface of the capsule. IEM 32 is present in a micro-environment member 36, as described above. The IEM 32 and micro-environment member 36 may be adhered to wall 12 using any convenient protocol, such as via a suitable physiologically acceptable adhesive material. Where desired, a wetting agent (not shown) may be associated with the micro-environment member 36, such as between the micro-environment member 36 and wall 12, so as to assure uniform wetting of the micro-environment member 36.

Instead of including a single IEM, osmotic capsules may include multiple IEMs stably and/or freely associated with different locations of the capsule. An example of such an osmotic capsule is shown in FIG. 5. In FIG. 5, osmotic capsule 10 includes hard-capsule component 31, osmotic member 21, semipermeable wall 12, passageway 13 and active agent composition 19, as described above. In addition, osmotic capsule 10 includes piston 22, as described above. Also shown are three different IEMs, 51, 52 and 53, which are integrated with different regions of the wall 12. Where desired, IEMs 51, 52 and 53 may include membranes which are co-manufactured with the wall 12. While IEMs 51, 52 and 53 are integrated with different regions of the wall 12, in some instances the multiple IEMs may be adhered to different surface locations of the outer surface of wall 12, for example in analogous fashion to that depicted in FIG. 4. Where desired, the IEMs 51, 52 and 53 may be configured to emit a signal only when the osmotic member 21 is level with the IEM. For example, as shown in FIG. 5, as osmotic member 21 imbibes fluid, piston 22 moves in the direction of the arrow. IEMs 51, 52 and 53 only activate and emit a signal when piston 22 passes the IEM and the osmotic member 21 becomes level with the IEM. As such, the osmotic capsule of this aspect is configured such that each IEM emits a signal when it is level with the osmotic member. This controlled activation may

be achieved using any convenient protocol, such as by including a necessary chemical reagent for IEM activation in the osmotic member 21. Such aspects provide for the ability to monitor delivery parameters of the osmotic capsule by evaluating the timing of signals received from the IEMs 51, 52 and 53. For example, by recording the timing of receipt of the signal from IEMs 51, 52 and 53, the rate of movement of piston 22 and therefore delivery of active agent from the osmotic capsule 10 may be readily determined.

As indicated above, one or more IEMs may be associated with a variety of different locations of an osmotic capsule. Examples of locations of an osmotic capsule where IEMs may be positioned include, but are not limited to, those locations depicted in FIG. 6. In FIG. 6, potential IEM locations 61, 62, 63, 64 and 65 are shown. A given osmotic capsule may include a single IEM at only one of these locations, or two or more IEMs at any two or more of these locations. Depending on the location, the IEM may be integrated with different components of the osmotic capsule and/or attached to the osmotic capsule component. Where the IEM is integrated with a given component (for example, the piston, a passageway plug, a capsule component, a semipermeable wall, etc.) it may be co-manufactured with that component, as desired.

#### 20 Liquid Capsule Ingestible Component

Another type of ingestible component of interest is a liquid capsule. Liquid capsules are ingestible components that include a shell (such as an outer capsule) filled with a liquid medium. The shell, for example outer capsule, may be a single component structure or a two-component structure, e.g., as described above in connection with osmotic capsule aspects, above. The liquid medium present inside of the shell may vary greatly, and may or may not include an active agent. While the shell may have a variety of configuration so long as it is configured to hold a desired amount of liquid medium (such as a liquid active agent composition), in certain aspects of interest the shell has a capsule configuration. As such, for ease of description only the shell will now be further described in terms of capsule configurations.

IEMs may include one or more IEMs stably associated in some manner with the liquid capsule. The IEM may be stably associated with the liquid capsule

in a variety of different ways. In some instances, the IEM is located in the liquid medium of the liquid capsule. In such instances, the IEM may be protected in some manner from the liquid medium. For example, the IEM may be coated with a coating that protects the IEM from the liquid medium.

5           When present, such as coating may cover one or more surfaces of the IEM or all of the surfaces of the IEM, such that the IEM is enveloped by the coating. Coatings of interest include pliable as well as non-pliable coatings. Coatings may take a variety of different configurations, such as layers, snap-fit pre-made structures, etc. When present, coatings may cover only a portion of  
10 the IEM or envelope the entire IEM. The coating may be uniform or non-uniform in terms of thickness.

          In certain instances, the coating is a pH sensitive coating covering various components of the IEM, where the pH sensitive coating only dissolves to expose the components when the desired pH conditions are present. pH sensitive  
15 coatings of interest include, but are not limited to: cellulose acetate phthalate, EUDRAGIT L™, EUDRAGIT S™, EUDRAGIT FS™, and other phthalate salts of cellulose derivatives. FIG. 7 provides a view of a configuration 70 that includes an outer capsule 72 containing a liquid medium 73, which liquid medium may contain an active agent. Present inside of outer capsule 72 is IEM 74. IEM 74 is  
20 coated with a pH sensitive coating 75. The pH sensitive coating may be chosen such that it remains intact in the liquid medium (for example where a low pH is present) but readily dissolves at higher pHs, such as the pH environment of the gastrointestinal tract.

          Where desired, the IEM (optionally coated with a protective layer, such as  
25 described above) that is located in the liquid medium may be present inside of a vesicle. The term "vesicle" is employed in its conventional sense to reference to a fluid filled compliant structure. For example, the IEM may be present inside of a lipid vesicle, e.g., where the liquid medium is an aqueous medium. FIG. 8 provides an example of an IEM according to this aspect. In FIG. 8, IEM 80  
30 includes outer capsule 81 containing aqueous liquid medium 82. Present in aqueous liquid medium 82 is vesicle 83, where IEM 84 is present in the vesicle 83. The vesicle may be fabricated from any convenient material, such as lipids etc., where the choice of material may depend, at least in part, on the nature of

the liquid medium, e.g., whether it is aqueous or non-aqueous, polar or non-polar, etc.

5 Instead of a vesicle, the IEM may be present in an encasing liquid that is immiscible with the liquid medium. For example, where the liquid medium is an aqueous liquid, the IEM may be present in a volume of a non-polar organic liquid that is immiscible in the aqueous liquid medium. As such, the IEM remains inside of the volume of immiscible encasing liquid when present in the liquid medium of the capsule.

10 Where desired, the IEM may be present in a sealed compartment inside of the outer capsule. FIG. 9 shows IEM 90 that includes outer capsule 91 and liquid medium 92. Barrier 94, in conjunction with capsule 91, defines an internal sealed compartment 95. Present inside of sealed compartment 95 is IEM 93.

15 In some instances, the IEM is integrated with the outer capsule. As the IEM is integrated with the outer capsule, in some aspects, the IEM cannot be removed from the remainder of the outer capsule without significantly compromising the structure and functionality of the outer capsule. In FIG. 10A, IEM 100 includes capsule cap 101 and capsule body 102. In capsule cap 101, IEM 103 is present, which is made up of IC component 104 and membrane 105. FIG. 10B provides an illustration of one protocol for fabricating the configuration shown in FIG. 10A. In the aspect illustrated in FIG. 10B, membrane 105 is provided in prefabricated capsule cap 101. Next, a hole 106 is provided in membrane 105, e.g., via punching or laser drilling. Following this step, IC component 104 is placed in hole 106 to produce IEM 103, where the IC component 104 may be held in place with an adhesive, as desired. FIG. 10A provides an illustration of an aspect where the membrane is integral with the capsule component of capsule IEM 100. In yet other aspects, the capsule component and the membrane may be the same structure. In those aspects where the IEM is integrated with the capsule, the IEM may be integrated at a variety of different locations, as desired. Accordingly, the IEM may be integrated  
25  
30 in the capsule at one of the poles, at a side location, etc.

IEM attachment via mechanical stable association

Ingestible event markers of the invention may include an ingestible  
5 component and one or more IEMs that are mechanically stably associated with  
the ingestible component. In these instances, the IEMs include an IEM that is  
mechanically stably associated with the ingestible component. By "mechanically  
stably associated" is meant that the stable association is provided by some  
mechanical component, such as a snap-fit component, etc. As such, the stable  
10 association is provided by non-chemical interaction, such as by friction or other  
physical forces. In IEMs of these aspects, the ingestible component may have  
any of a variety of different configurations, such as tablets, capsules, etc.

In some instances, the IEM has a structure in which the ingestible  
component is present in an encasement that comprises the IEM, for example  
15 whether the IEM is integrated with the encasement or a component thereof. The  
encasement of such aspects may have any convenient configuration, so long as  
it encases the ingestible component. For example, the encasement may include  
a lid and a container configured to associate with each other in a manner  
sufficient to encase the ingestible component. An example of such an IEM is  
20 shown in FIG. 11. In FIG. 11, IEM 110 includes ingestible component 112 in the  
form of a tablet. Tablet 112 is present inside of container 114. Also shown is lid  
113 which is associated with container 114 to encase tablet 112. Lid 113  
includes integrated IEM 115. The association of lid 113 and container 114 may  
vary, so long as the association is stable and provides for the encasement of  
25 tablet 112. For example, lid 113 may be stably associated with container 114  
with an adhesive. In such instances, while lid 113 is associated with container  
114 by an adhesive, the tablet 112 is maintained in the encasement structure  
merely by physical entrapment in the encasement structure, so as to minimize  
any modification to the tablet 112. Instead of an adhesive, the lid and container  
30 may be configured to have a snap-fit relationship with each other, such that the  
lid and container are configured to snap-fit together. In such instances, pressure  
is applied to the lid and/or container to associate the two structures with each  
other. Once associated, the pressure may be removed and the two components  
will remain stably associated with each other.

Instead of being associated with an encasement, the IEM may include a non-encasing component that is configured to mechanically stably associate with the ingestible component, where the non-encasing component comprises the IEM. As this IEM comprising component is non-encasing, upon association with the ingestible component, it covers a portion of the surface of the ingestible component but not the entire surface of the ingestible component. Non-encasing components of interest may have a variety of different configurations, such as bands, clips, cuffs, sleeves, clamps, claws, etc. The non-encasing component may be fabricated from any convenient material, where materials of interest include physiologically acceptable elastomeric materials that are compatible with a given IEM that is to be employed. An example of an IEM that includes a non-encasing component is illustrated in FIG. 12. In FIG. 12, IEM 120 includes ingestible component 122 in the form of a tablet. Band 124 is fabricated from an elastomeric material and is configured to fit over and securely associate with the tablet 122 as shown. Integrated into band 124 is IEM 126, as shown.

Instead of being integrated in a band or analogous structure, such as shown in FIG. 12, the IEM may be separate from the non-encasing component and yet stably associated with the ingestible component by the non-encasing component. In such instances, the non-encasing component may be configured to change conformation upon contact of the IEM with the target site so as to separate the IEM from the ingestible component. For example, the non-encasing component may have a configuration and be fabricated from a material such that, upon contact with a target site, the non-encasing component or a portion thereof swells (for example, upon absorption of water) such that the non-encasing component changes shape and is released from the ingestible component. Upon release from the ingestible component, the non-encasing component releases one or IEMs that were stably associated with the ingestible component by the non-encasing component, for example where the IEMs were present between the ingestible component and the non-encasing component. In these aspects, the non-encasing component may be shaped in a variety of different ways, such as band-shaped, star-shaped, daisy-shaped, etc. The non-encasing component may be fabricated from a variety of different types of materials, where materials of interest include polymeric materials, such as described above.

In some instances, the ingestible component includes an IEM receiving element configured to receive the IEM, where the IEM is configured to be retained in the receiving element following placement therein by mechanical forces. The receiving element may vary in terms of configuration. Examples of receiving element configurations include grooves, cup-shapes, or more complex structures, where the configuration may depend, at least in part, on the configuration of the IEM that is to be mechanically stably associated in the receiving element. For example, the IEM may be configured to press-fit into the receiving element. As such, once the IEM is positioned in the receiving element, the IEM is maintained in the receiving element without any additional applied force and/or chemical adhesives. To provide for this relationship, the IEM may include a flexible component that conforms to the receiving element upon placement of the IEM into the receiving element. The flexible component may be any component of the IEM. In some instances, the flexible component may be a membrane of the IEM. An example of an IEM as described above is shown in FIGS. 13A and 13B. FIG. 13A provides a view of IEM 130 prior to assembly. IEM 130 includes ingestible component 131 in the form of a tablet. Tablet 131 includes IEM receiving element 135 that is configured and dimensioned to receive IEM 132. IEM 132 includes IC component 134 and flexible membrane 133. To assemble IEM 130, IEM 132 is positioned in receiving element 135 as shown by the arrow in FIG. 13A to produce the assembled IEM 130 shown in FIG. 13B. The diameter of flexible membrane 133 is slightly larger than the diameter of receiving element 135. As such, the IEM 132 may be pressed into the receiving element 131, but will then stay in position in the receiving element following removal of any pressing force.

Where desired, the flexible component (such as the membrane or another structure) may be configured to be folded during placement into the receiving element. In such configurations, following placement of the IEM in the receiving element, the folded flexible component may be allowed to unfold to secure the IEM in the receiving element. The flexible component of such IEMs may have a variety of different configurations that are amenable to manipulation (such as folding) to provide for insertion into the receiving element, as described above. Configurations of interest include both simple configurations, such as disc-

shaped configurations, or more complex configurations, such as star-shaped configurations.

In some instances, the IEM may include a feature that mates with one a feature of the ingestible component. For example, the IEM may include a hole,  
5 for example in a membrane, which receives a corresponding protrusion, such as a peg, of the ingestible component. When the protrusion is placed through the hole, the IEM becomes stably associated with the ingestible component. These mating features may be configured to have a snap-fit relationship, e.g., as described above.

10

#### Multi-layered Ingestible Components

Another type of ingestible component of interest is a multi-layered ingestible component, where the ingestible component includes two or more  
15 distinct layers of material. Multi-layered ingestible components are not homogenous ingestible components, in which there is no variation throughout the ingestible component in terms of composition. Multi-layered ingestible components may include only two distinct layers, more than two layers, such as three, four, five, ten, fifteen or even twenty layers or more. The different layers  
20 may or may not be separated from each other by a barrier material, as desired. Each layer may have the same or different composition. In some instances, the different layers may have the same active agent in the same concentration. Alternatively, the different layers may have the same active agent but in differing concentrations. In yet other aspects, two or more different active agents may be  
25 present in two or more different layers. As with the active agents, the vehicle component of the layers may be the same or different, as desired, e.g., to provide for desired controlled release profiles, and the like.

Associated with one or more of the layers the multi-layered ingestible component is one or more IEMs. An IEM may be present in only one, some or all  
30 of the layers of a multi-layered ingestible component. In some instances, the layer or layers in which an IEM is present are layers that do not include an active agent. Alternatively, IEM-containing layers may also contain an active agent. Where multiple layers include IEMs, the IEMs may activate at different times and/or locations of the GI tract to provide information regarding when an active



agent was released from the ingestible component. In multi-layered ingestible components where the IEM layers alternate with active agent layers, the ingestible component may be configured such that active agent from a given layer is only released following activation of an IEM in the layer above that active agent layer. Multi-IEM multi-layered ingestible components may be configured such that different IEMs send different signals (for example that differ from each other in terms of ID), so that dissolution of each layer of the multi-layered ingestible component may be detected and/or monitored, as desired.

The multi-layered ingestible component may or may not include non-multi-layered elements. For example, multi-layered ingestible components of interest include multi-layered tablets. Also of interest are capsules that have multiple layers present inside an outer shell component. Also of interest are tablets and capsules that have a distinct multi-layer component, e.g., as described above, stably associated with non-multi-layered tablet or capsule. For example, the IEM may include a multilayered membrane. All such formats are considered multi-layered ingestible components because they include a multi-layer element, e.g., as described above.

The ingestible component may also be configured so that the IEM can activate in a manner that is independent of any controlled release profile of the remainder of the ingestible component. For example, the IEM may be present in a first layer configured so that the IEM present therein is activated upon contact with a desired physiological site, such as the stomach or small intestine. In these aspects, the ingestible component may include a second layer that is configured to provide for controlled release of an active agent.

25

#### Multi-Compartment Ingestible Components

Also of interest as ingestible components are multi-compartment ingestible components. Multi-compartment ingestible components are ingestible components that include two or more distinct compartments or regions that are distinct from other in terms of one or more parameters, such as dissolution profile, composition, etc. In such ingestible components, an IEM is associated with at least one of the compartments. Multi-compartment ingestible components may be configured to separate the one or more IEMs from the remainder of the

30

ingestible component to provide for one or more desired characteristics. For example, the IEM may be positioned in a compartment distinct from the remainder of the ingestible component in order to protect the IEM from other constituents of the ingestible component, such as the active agent, from moisture, e.g., as may be present in a liquid containing ingestible component, etc.; also, stability, e.g., to provide for stability of the IEM and components thereof. Alternatively, the multi-compartment ingestible component may be configured to provide for a desired environment for the IEM when active, e.g., by providing a controlled ion concentration, such as described in application serial no. PCT/US2007/082563 published as WO 2008/052136 the disclosure of which is herein incorporated by reference, and/or controlled activation, e.g., in response to a predetermined environmental condition, such as pH.

The ingestible component may also be configured so that the IEM can activate in a manner that is independent of any controlled release profile of the remainder of the ingestible component. For example, the IEM may be present in a first compartment configured so that the IEM present therein is activated upon contact with a desired physiological site, such as the stomach or small intestine. In these aspects, the ingestible component may include a second compartment that is configured to provide for controlled release of an active agent.

Also of interest ingestible components that include a controlled release compartment, where the controlled release compartment includes an IEM. In such ingestible components, the IEM may be activated at with release of the active agent from the controlled release compartment begins, such that an IEM communication may be used to determine the onset of active agent delivery from the controlled release compartment.

#### *Active Agent*

Where desired, the IEM and/or ingestible component may include an active agent. The active agent, when present, may be present in the IEM, ingestible component, the membrane, or both. Active agents of interest include pharmaceutically active agents as well as non-pharmaceutical active agents, such as diagnostic agents.

The phrase "pharmaceutically active agent" (also referred to herein as drugs) refers to a compound or mixture of compounds which produces a

physiological result, e.g., a beneficial or useful result, upon contact with a living organism, e.g., a mammal, such as a human. Pharmaceutically active agents are distinguishable from such components as excipients, carriers, diluents, lubricants, binders and other formulating aids, and encapsulating or otherwise protective components. The pharmaceutically active agent may be any molecule, as well as binding portion or fragment thereof, that is capable of modulating a biological process in a living subject. In certain aspects, the pharmaceutically active agent may be a substance used in the diagnosis, treatment, or prevention of a disease or as a component of a medication. In certain aspects, the pharmaceutically active agent may be a chemical substance, such as a narcotic or hallucinogen, which affects the central nervous system and causes changes in behavior. The pharmaceutically active agent is capable of interacting with a target in a living subject. The target may be a number of different types of naturally occurring structures, where targets of interest include both intracellular and extracellular targets. Such targets may be proteins, phospholipids, nucleic acids and the like, where proteins are of particular interest. Specific proteinaceous targets of interest include, without limitation, enzymes, e.g., kinases, phosphatases, reductases, cyclooxygenases, proteases and the like, targets comprising domains involved in protein-protein interactions, such as the SH2, SH3, PTB and PDZ domains, structural proteins, e.g., actin, tubulin, etc., membrane receptors, immunoglobulins, e.g., IgE, cell adhesion receptors, such as integrins, etc., ion channels, transmembrane pumps, transcription factors, signaling proteins, and the like.

The pharmaceutically active agent may include one or more functional groups necessary for structural interaction with the target, e.g., groups necessary for hydrophobic, hydrophilic, electrostatic or even covalent interactions, depending on the particular drug and its intended target. Where the target is a protein, the pharmaceutically active agent may include functional groups necessary for structural interaction with proteins, such as hydrogen bonding, hydrophobic-hydrophobic interactions, electrostatic interactions, etc., and may include at least an amine, amide, sulfhydryl, carbonyl, hydroxyl or carboxyl group, such as at least two of the functional chemical groups.

Pharmaceutically active agents of interest may include cyclical carbon or heterocyclic structures and/or aromatic or polyaromatic structures substituted

with one or more of the above functional groups. Also of interest as pharmaceutically active agents are compounds having structures found among biomolecules, including peptides, saccharides, fatty acids, steroids, purines, pyrimidines, derivatives, structural analogs or combinations thereof. Such compounds may be screened to identify those of interest, where a variety of different screening protocols are known in the art.

The pharmaceutically active agent may be derived from a naturally occurring or synthetic compound that may be obtained from a wide variety of sources, including libraries of synthetic or natural compounds. For example, numerous means are available for random and directed synthesis of a wide variety of organic compounds and biomolecules, including the preparation of randomized oligonucleotides and oligopeptides. Alternatively, libraries of natural compounds in the form of bacterial, fungal, plant and animal extracts are available or readily produced. Additionally, natural or synthetically produced libraries and compounds are readily modified through conventional chemical, physical and biochemical means, and may be used to produce combinatorial libraries. Known pharmacological agents may be subjected to directed or random chemical modifications, such as acylation, alkylation, esterification, amidification, etc. to produce structural analogs.

As such, the pharmaceutically active agent may be obtained from a library of naturally occurring or synthetic molecules, including a library of compounds produced through combinatorial means, i.e., a compound diversity combinatorial library. When obtained from such libraries, the drug moiety employed will have demonstrated some desirable activity in an appropriate screening assay for the activity.

Broad categories of active agents of interest include, but are not limited to: cardiovascular agents; pain-relief agents, e.g., analgesics, anesthetics, anti-inflammatory agents, etc.; nerve-acting agents; chemotherapeutic (e.g., anti-neoplastic) agents; neurological agents, e.g., anti-convulsants, etc.

In certain aspects, the active agent is a cardiovascular agent, i.e., an agent employed in the treatment of cardiovascular or heart conditions. In certain aspects, the active agent is a cardiovascular agent, i.e., an agent employed in the treatment of cardiovascular or heart conditions. Cardiovascular agents of interest include, but are not limited to: cardioprotective agents, e.g., Zinecard

(dexrazoxane); blood modifiers, including anticoagulants (e.g., coumadin (warfarin sodium), fragmin (dalteparin sodium), heparin, innohep (tinzaparin sodium), lovenox (enoxaparin sodium), orgaran (danaparoid sodium)) antiplatelet agents (e.g., aggrasta (tirofiban hydrochloride), aggrenox (aspirin/extended release dipyridamole), agrylin (anagrelide hydrochloride), ecotrin (acetylsalicylic acid), folan (epoprostenol sodium), halfprin (enteric coated aspirin), integrilin (eptifibatide), persantine (dipyridamole USP), plavix (clopidogrel bisulfate), pletal (cilostazol), reopro (abciximab), ticlid (ticlopidine hydrochloride)), thrombolytic agents (activase (alteplase), retavase (reteplase), streptase (streptokinase)); adrenergic blockers, such as cardura (doxazosin mesylate), dibenzylamine (phenoxybenzamine hydrochloride), hytrin (terazosin hydrochloride), minipress (prazosin hydrochloride), minizide (prazosin hydrochloride/polythiazide); adrenergic stimulants, such as aldomet (methyldopa – chlorothiazide), aldomet (methyldopa, methyldopate HCl), aldoril (methyldopa – hydrochlorothiazide), catapres (clonidine hydrochloride USP, clonidine), clorpres (clonidine hydrochloride and chlorthalidone), combipres (clonidine hydrochloride/chlorthalidone), tenex (guanfacine hydrochloride); alpha/bet adrenergic blockers, such as coreg (carvedilol), normodyne (labetalol hydrochloride); angiotensin converting enzyme (ACE) inhibitors, such as accupril (quinapril hydrochloride), aceon (perindopril erbumine), altace (ramipril), captopril, lotensin (benazepril hydrochloride), mavik (trandolapril), monopril (fosinopril sodium tablets), prinivil (lisinopril), univasc (moexipril hydrochloride), vasotec (enalaprilat, enalapril maleate), zestril (lisinopril); angiotensin converting enzyme (ACE) inhibitors with calcium channel blockers, such as lexxel (enalapril maleate – felodipine ER), lotrel (amlodipine and benazepril hydrochloride), tarka (trandolapril/verapamil hydrochloride ER); angiotensin converting enzyme (ACE) inhibitors with diuretics, such as accuretic (quinapril HCl/hydrochlorothiazide), lotensin (benazepril hydrochloride and hydrochlorothiazide USP), prinizide (lisinopril–hydrochlorothiazide), uniretic (moexipril hydrochloride/hydrochlorothiazide), vaseretic (enalapril maleate – hydrochlorothiazide), zestoretic (lisinopril and hydrochlorothiazide); angiotensin II receptor antagonists, such as atacand (candesartan cilexetil), avapro (irbesartan), cozaar (losartan potassium), diovan (valsartan), micardis (telmisartan), teveten (eprosartan mesylate); angiotensin II receptor antagonists with diuretics, such as avalide (irbesartan –

hydrochlorothiazide), diovan (valsartan and hydrochlorothiazide), hyzaar (losartan potassium – hydrochlorothiazide); antiarrhythmics, such as Group I (e.g., mexitil (mexiletine hydrochloride, USP), norpace (disopyramide phosphate), procanbid (procainamide hydrochloride), quinaglute (quinidine gluconate),  
5 quinidex (quinidine sulfate), quinidine (quinidine gluconate injection, USP), rythmol (propafenone hydrochloride), tambocor (flecainide acetate), tonocard (tocainide HCl), Group II (e.g., betapace (sotalol HCl), brevbloc (esmolol hydrochloride), inderal (propranolol hydrochloride), sectral (acebutolol hydrochloride)), Group III (e.g., betapace (sotalol HCl), cordarone (amiodarone hydrochloride), corvert (ibutilide fumarate injection), pacerone (amiodarone HCl),  
10 tikosyn (dofetilide)), Group IV (e.g., calan (verapamil hydrochloride), cardizem (diltiazem HCl), as well as adenocard (adenosine), lanoxicaps (digoxin), lanoxin (digoxin)); antilipemic acids, including bile acid sequestrants (e.g., colestid (micronized colestipol hydrochloride), welchol (colesevelam hydrochloride)), fibric acid derivatives (e.g., atromid (clofibrate), lopid (gemfibrozil tablets, USP), tricor (fenofibrate capsules)), HMG-CoA reductase inhibitors (e.g., baycol (cerivastatin sodium tablets), lescol (fluvastatin sodium), lipitor (atorvastatin calcium), mevacor (lovastatin), pravachol (pravastatin sodium), zocor (simvastatin)), Nicotinic Acid (e.g., Niaspan (niacin extended release tablets)); beta adrenergic blocking  
20 agents, e.g., betapace (sotalol HCl), blocadren (timolol maleate), brevbloc (esmolol hydrochloride), cartrol (carteolol hydrochloride), inderal (propranolol hydrochloride), kerlone (betaxolol hydrochloride), nadolol, sectral (acebutolol hydrochloride), tenormin (atenolol), toprol (metoprolol succinate), zebeta (bisoprolol fumarate); beta adrenergic blocking agents with diuretics, e.g., corzide  
25 (nadolol and bendroflumethiazide tablets), inderide (propranolol hydrochloride and hydrochlorothiazide), tenoretic (atenolol and chlorthalidone), timolide (timolol maleate – hydrochlorothiazide), ziac (bisoprolol fumarate and hydrochlorothiazide); calcium channel blockers, e.g., adalat (nifedipine), calan (verapamil hydrochloride), cardene (nicardipine hydrochloride), cardizem (diltiazem HCl),  
30 covera (verapamil hydrochloride), isoptin (verapamil hydrochloride), nimotop (nimodipine), norvasc (amlodipine besylate), plendil (felodipine), procardia (nifedipine), sular (nisoldipine), tiazac (diltiazem hydrochloride), vascor (bepridil hydrochloride), verelan (verapamil hydrochloride); diuretics, including carbonic anhydrase inhibitors (e.g., daranide (dichlorphenamide)), combination diuretics

(e.g., aldactazide (spironolactone with hydrochlorothiazide), dyazide (triamterene and hydrochlorothiazide), maxzide (triamterene and hydrochlorothiazide), moduretic (amiloride HCl - hydrochlorothiazide)), loop diuretics (demadex (torsemide), edecrin (ethacrynic acid, ethacrynate sodium), furosemide),  
5 potassium-sparing diuretics (aldactone (spironolactone), dyrenium (triamterene), midamor (amiloride HCl)), thiazides & related diuretics (e.g., diucardin (hydroflumethiazide), diuril (chlorothiazide, chlorothiazide sodium), enduron (methyclothiazide), hydrodiuril hydrochlorothiazide), indapamide, microzide (hydrochlorothiazide) mykrox (metolazone tablets), renesse (polythi-azide),  
10 thalitone (chlorthalidone, USP), zaroxolyn (metolazone)); inotropic agents, e.g., digitek (digoxin), dobutrex (dobutamine), lanoxicaps (digoxin), lanoxin (digoxin), primacor (milrinone lactate); activase (alteplase recombinant); adrenaline chloride (epinephrine injection, USP); demser (metyrosine), inversine (mecamylamine HCl), reopro (abciximab), retavase (reteplase), streptase (streptokinase), tkase  
15 (tenecteplase); vasodilators, including coronary vasodilators (e.g., imdur (isosorbide mononitrate), ismo (isosorbide mononitrate), isordil (isosorbide dinitrate), nitrodur (nitroglycerin), nitrolingual (nitroglycerin lingual spray), nitrostat (nitroglycerin tablets, USP), sorbitrate (isosorbide dinitrate)), peripheral vasodilators & combinations (e.g., corlopam (fenoldopam mesylate), fiolan  
20 (epoprostenol sodium), primacor (milrinone lactate)), vasopressors, e.g., aramine (metaraminol bitartrate), epipen (EpiPen 0.3 mg brand of epinephrine auto injector, EpiPen Jr. 0.15 mg brand of epinephrine auto injector), proamatine (midodrine hydrochloride); etc.

In certain aspects, specific drugs of interest include, but are not limited to:  
25 psychopharmacological agents, such as (1) central nervous system depressants, e.g. general anesthetics (barbiturates, benzodiazepines, steroids, cyclohexanone derivatives, and miscellaneous agents), sedative-hypnotics (benzodiazepines, barbiturates, piperidinediones and triones, quinazoline derivatives, carbamates, aldehydes and derivatives, amides, acyclic ureides, benzazepines and related  
30 drugs, phenothiazines, etc.), central voluntary muscle tone modifying drugs (anticonvulsants, such as hydantoins, barbiturates, oxazolinediones, succinimides, acylureides, glutarimides, benzodiazepines, secondary and tertiary alcohols, dibenzazepine derivatives, valproic acid and derivatives, GABA analogs, etc.), analgesics (morphine and derivatives, oripavine derivatives,

morphinan derivatives, phenylpiperidines, 2,6-methane-3-benzazocaine derivatives, diphenylpropylamines and isosteres, salicylates, p-aminophenol derivatives, 5-pyrazolone derivatives, arylacetic acid derivatives, fenamates and isosteres, etc.) and antiemetics (anticholinergics, antihistamines, 5 antidopaminergics, etc.), (2) central nervous system stimulants, e.g. analeptics (respiratory stimulants, convulsant stimulants, psychomotor stimulants), narcotic antagonists (morphine derivatives, oripavine derivatives, 2,6-methane-3-benzoxacine derivatives, morphinan derivatives) nootropics, (3) psychopharmacologicals, e.g. anxiolytic sedatives (benzodiazepines, propanediol 10 carbamates) antipsychotics (phenothiazine derivatives, thioxanthine derivatives, other tricyclic compounds, butyrophenone derivatives and isosteres, diphenylbutylamine derivatives, substituted benzamides, arylpiperazine derivatives, indole derivatives, etc.), antidepressants (tricyclic compounds, MAO inhibitors, etc.), (4) respiratory tract drugs, e.g. central antitussives (opium 15 alkaloids and their derivatives); pharmacodynamic agents, such as (1) peripheral nervous system drugs, e.g. local anesthetics (ester derivatives, amide derivatives), (2) drugs acting at synaptic or neuroeffector junctional sites, e.g. cholinergic agents, cholinergic blocking agents, neuromuscular blocking agents, adrenergic agents, antiadrenergic agents, (3) smooth muscle active drugs, e.g. 20 spasmolytics (anticholinergics, musculotropic spasmolytics), vasodilators, smooth muscle stimulants, (4) histamines and antihistamines, e.g. histamine and derivative thereof (betazole), antihistamines (H1-antagonists, H2-antagonists), histamine metabolism drugs, (5) cardiovascular drugs, e.g. cardiotonics (plant extracts, butenolides, pentadienolids, alkaloids from erythrophleum species, 25 ionophores, -adrenoceptor stimulants, etc), antiarrhythmic drugs, antihypertensive agents, antilipidemic agents (clofibric acid derivatives, nicotinic acid derivatives, hormones and analogs, antibiotics, salicylic acid and derivatives), antivaricose drugs, hemostyptics, (6) blood and hemopoietic system drugs, e.g. antianemia drugs, blood coagulation drugs (hemostatics, 30 anticoagulants, antithrombotics, thrombolytics, blood proteins and their fractions), (7) gastrointestinal tract drugs, e.g. digestants (stomachics, choleric), antiulcer drugs, antidiarrheal agents, (8) locally acting drugs;

chemotherapeutic agents, such as (1) anti-infective agents, e.g. ectoparasiticides (chlorinated hydrocarbons, pyrethins, sulfurated compounds),



anthelmintics, antiprotozoal agents, antimalarial agents, antiamebic agents, antileishmanial drugs, antitrichomonal agents, antitrypanosomal agents, sulfonamides, antimycobacterial drugs, antiviral chemotherapeutics, etc., and (2) cytostatics, i.e. antineoplastic agents or cytotoxic drugs, such as alkylating agents, e.g. Mechlorethamine hydrochloride (Nitrogen Mustard, Mustargen, HN2), Cyclophosphamide (Cytovan, Endoxana), Ifosfamide (IFEX), Chlorambucil (Leukeran), Melphalan (Phenylalanine Mustard, L-sarcosine, Alkeran, L-PAM), Busulfan (Myleran), Thiotepa (Triethylenethiophosphoramide), Carmustine (BiCNU, BCNU), Lomustine (CeeNU, CCNU), Streptozocin (Zanosar) and the like; plant alkaloids, e.g. Vincristine (Oncovin), Vinblastine (Velban, Velbe), Paclitaxel (Taxol), and the like; antimetabolites, e.g. Methotrexate (MTX), Mercaptopurine (Purinethol, 6-MP), Thioguanine (6-TG), Fluorouracil (5-FU), Cytarabine (Cytosar-U, Ara-C), Azacitidine (Mylosar, 5-AZA) and the like; antibiotics, e.g. Dactinomycin (Actinomycin D, Cosmegen), Doxorubicin (Adriamycin), Daunorubicin (daunomycin, Cerubidine), Idarubicin (Idamycin), Bleomycin (Blenoxane), Picamycin (Mithramycin, Mithracin), Mitomycin (Mutamycin) and the like, and other anticellular proliferative agents, e.g. Hydroxyurea (Hydrea), Procarbazine (Mutalane), Dacarbazine (DTIC-Dome), Cisplatin (Platinol) Carboplatin (Paraplatin), Asparaginase (Elspar) Etoposide (VePesid, VP-16-213), Amsacrine (AMSA, m-AMSA), Mitotane (Lysodren), Mitoxantrone (Novatrone), and the like;

antibiotics, such as: aminoglycosides, e.g. amikacin, apramycin, arbekacin, bambarmycins, butirosin, dibekacin, dihydrostreptomycin, fortimicin, gentamicin, isepamicin, kanamycin, micromycin, neomycin, netilmicin, paromycin, ribostamycin, sisomicin, spectinomycin, streptomycin, tobramycin, trospectomycin; amphenicols, e.g. azidamfenicol, chloramphenicol, florfenicol, and thiomphenicol; ansamycins, e.g. rifamide, rifampin, rifamycin, rifapentine, rifaximin; b-lactams, e.g. carbacephems, carbapenems, cephalosporins, cephamycins, monobactams, oxaphems, penicillins; lincosamides, e.g. clinamycin, lincomycin; macrolides, e.g. clarithromycin, dirithromycin, erythromycin, etc.; polypeptides, e.g. amphotericin, bacitracin, capreomycin, etc.; tetracyclines, e.g. apicycline, chlortetracycline, clomocycline, etc.; synthetic antibacterial agents, such as 2,4-diaminopyrimidines, nitrofurans, quinolones and analogs thereof, sulfonamides, sulfones;

antifungal agents, such as: polyenes, e.g. amphotericin B, candicidin, dermostatin, filipin, fungichromin, hachimycin, hamycin, lucensomycin, mepartricin, natamycin, nystatin, pecilocin, perimycin; synthetic antifungals, such as allylamines, e.g. butenafine, naftifine, terbinafine; imidazoles, e.g. bifonazole, butoconazole, chlordantoin, chlormidazole, etc., thiocarbamates, e.g. tolclate, triazoles, e.g. fluconazole, itraconazole, terconazole;

anthelmintics, such as: arecoline, aspidin, aspidinol, dichlorophene, embelin, kosin, naphthalene, niclosamide, pelletierine, quinacrine, alantolactone, amocarzine, amoscanate, ascaridole, bethovenium, bitoscanate, carbon tetrachloride, carvacrol, cyclobendazole, diethylcarbamazine, etc.;

antimalarials, such as: acedapsone, amodiaquin, arteether, artemether, artemisinin, artesunate, atovaquone, bebeerine, berberine, chirata, chlorguanide, chloroquine, chlorproguanil, cinchona, cinchonidine, cinchonine, cycloguanil, gentiopicrin, halofantrine, hydroxychloroquine, mefloquine hydrochloride, 3-methylarsacetin, pamaquine, plasmocid, primaquine, pyrimethamine, quinacrine, quinidine, quinine, quinocide, quinoline, dibasic sodium arsenate;

antiprotozoan agents, such as: acranil, tinidazole, ipronidazole, ethylstibamine, pentamidine, acetarsone, aminitrozole, anisomycin, nifuratel, tinidazole, benzidazole, suramin, and the like.

Name brand drugs of interest include, but are not limited to: Lovastatin™ drug, Enalapril™ drug, Prozac™ drug, Prilosec™ drug, Lipotor™ drug, Claritin™ drug, Zocor™ drug, Ciprofloxacin™ drug, Viagra™ drug, Crixivan™ drug, Ritalin™ drug, and the like.

Drug compounds of interest are also listed in: Goodman & Gilman's, The Pharmacological Basis of Therapeutics (9th Ed) (Goodman et al. eds) (McGraw-Hill) (1996); and 2001 Physician's Desk Reference.

Also of interest are analogs of the above compounds.

For all of the above active agents, the active agents may be present as pharmaceutically acceptable salts.

Also of interest as active agents are diagnostic agents. Diagnostic agents of interest include agents useful in fluorescence and X-ray diagnostic procedures, among others. Specific types of agents of interest include isotopic agents (for

example radioactive dyes or metabolites), fluorescent agents, radio-opaque agents, etc.

The amount of active agent that is present in the IEM may vary. In some instances, the amount of active agent that is present in the membrane may range  
5 from 0.01 to 100% by weight.

#### IEM MANUFACTURE

A variety of manufacturing protocols may be employed to produce aspects  
10 of the invention. The IEM and membrane components may be produced as described above. The IEM may be stably associated with the ingestible component in some manner. The IEM may be stably associated with the vehicle in a number of different ways, e.g., as described above. IEM fabrication protocols of interest include, but are not limited to, those described in PCT application  
15 serial nos. PCT/US2006/016370 and PCT/US08/77753; as well as in United States Provisional Application Serial No. 61/142,849; the disclosures of which are herein incorporated by reference.

#### SYSTEMS

20 Also provided are systems that include an IEM and a detection component, e.g., in the form of a receiver. Receivers of interest are those that are configured to detect, e.g., receive, a communication from an IEM. The signal detection component may vary significantly depending on the nature of the communication that is generated by the IEM. As such, the receiver may be  
25 configured to receive a variety of different types of signals, including but not limited to: RF signals, magnetic signals, conductive (near field) signals, acoustic signals, etc. In certain aspects, the receiver is configured to receive a signal conductively from an IEM, such that the two components use the body of the  
30 patient as a communication medium. As such, communication that is transferred between IEM and the receiver travels through the body, and requires the body as the conduction medium. The IEM communication may be transmitted through and received from the skin and other body tissues of the subject body in the form of electrical alternating current (a.c.) voltage signals that are conducted through

the body tissues. As a result, such aspects do not require any additional cable or hard wire connection, or even a radio link connection for transmitting the sensor data from the autonomous sensor units to the central transmitting and receiving unit and other components of the system, since the sensor data are directly  
5 exchanged via the skin and other body tissues of the subject. This communication protocol has the advantage that the receivers may be adaptably arranged at any desired location on the body of the subject, whereby the receivers are automatically connected to the required electrical conductor for achieving the signal transmission, i.e., the signal transmission is carried out  
10 through the electrical conductor provided by the skin and other body tissues of the subject.

The receiver may include a variety of different types of receiver elements, where the nature of the receiver element necessarily varies depending on the nature of the signal produced by the signal generation element. In certain  
15 aspects, the receiver may include one or more electrodes, e.g., 2 or more electrodes, 3 or more electrodes, and/or includes multiple, e.g., 2 or more, 3 or more, 4 or more pairs of electrodes, etc., for detecting communications associated with an IEM. In certain aspects, the receiver includes two or three electrodes that are dispersed at a distance from each other, e.g., a distance that  
20 allows the electrodes to detect a differential voltage. The distance between any two electrodes may vary, and in certain aspects ranges from about 0.1 to about 5 cm, such as from about 0.5 to about 2.5 cm, e.g., about 1 cm.

In addition to signal receiving elements, such as electrodes, receivers of the invention may include one or more integrated circuit components, one or  
25 more power components (such as power receivers or batteries), signal transmission components, housing components, etc.

The receivers of interest include both external and implantable receivers. In external aspects, the receiver is *ex vivo*, by which is meant that the receiver is present outside of the body during use. Where the receiver is implanted, the  
30 receiver is *in vivo*. The receiver is configured to be stably associated with the body, e.g., either *in vivo* or *ex vivo*, at least during the time that it receives communication from the IEM.

In certain aspects, the receiver is configured to provide data of a received signal to a location external to said subject. For example, the receiver may be

configured to provide data to an external data receiver, e.g., which may be in the form of a monitor (such as a bedside monitor), a computer, a personal digital assistant (PDA), phone, messaging device, smart phone, etc. The receiver may be configured to retransmit data of a received communication to the location  
5 external to said subject. Alternatively, the receiver may be configured to be interrogated by an external interrogation device to provide data of a received signal to an external location.

Receivers of interest include, but are not limited to, those receivers disclosed in: PCT application serial nos. PCT/US2006/016370 published as WO  
10 2006/116718; PCT/US2008/52845 published as WO 2008/095183; PCT/US2007/024225 published as WO 2008/063626 and PCT/US2008/085048; as well as United States Provisional Application Serial No. 61/160,289; the disclosures of which applications (and particularly receiver components thereof) are herein incorporated by reference.

15 Systems of the invention may include an external device which is distinct from the receiver (which may be implanted or topically applied in certain aspects), where this external device provides a number of functionalities. Such an apparatus can include the capacity to provide feedback and appropriate clinical regulation to the patient. Such a device can take any of a number of forms. By  
20 example, the device can be configured to sit on the bed next to the patient, e.g., a bedside monitor. Other formats include, but are not limited to, PDAs, phones, such as smart phones, computers, etc. The device can read out the information described in more detail in other sections of the subject patent application, both from pharmaceutical ingestion reporting and from physiological sensing devices,  
25 such as is produced internally by a pacemaker device or a dedicated implant for detection of the pill. The purpose of the external apparatus is to get the data out of the patient and into an external device. One feature of the external apparatus is its ability to provide pharmacologic and physiologic information in a form that can be transmitted through a transmission medium, such as a telephone line, to a  
30 remote location such as a clinician or to a central monitoring agency.

#### *METHODS*

Aspects of the invention further include methods of using IEMs, such as those described above. Methods of the invention generally include administering an IEM to a subject, e.g., by self-administration or via the assistance of another, such as a health care practitioner. Generally, methods of the invention will include placing the in the mouth of a subject such that the subject swallows the IEM. In this manner, the subject ingests the IEM. IEMs may be employed with a variety of subjects. Generally such subjects are "mammals" or "mammalian," where these terms are used broadly to describe organisms which are within the class mammalia, including the orders carnivore (e.g., dogs and cats), rodentia (e.g., mice, guinea pigs, and rats), and primates (e.g., humans, chimpanzees, and monkeys). In certain aspects, the subjects will be humans.

Following ingestion, the methods include emitting one or more signals from the ingested IEM, for example when the IEM contacts the target physiological site. As reviewed above, the nature of the emitted signal may vary greatly. In some instances, the emitted signal is a conductively transmitted signal. Methods of the invention may also include receiving a signal emitted from an IEM, e.g., at a receiver, such as described above. In some instances, the received signal is a conductively transmitted signal.

IEMs may be employed in a variety of different applications. Applications of interest include, but are not limited to: monitoring patient compliance with prescribed therapeutic regimens; tailoring therapeutic regimens based on patient compliance; monitoring patient compliance in clinical trials; monitoring usage of controlled substances; monitoring the occurrence of a personal event of interest, such as the onset of symptoms, etc., and the like. Applications of interest are further described in PCT application serial no. PCT/US2006/016370 published as WO/2006/116718; PCT application serial no. PCT/US2007/082563 published as WO/2008/052136; PCT application serial no. PCT/US2007/024225 published as WO/2008/063626; PCT application serial no. PCT/US2007/022257 published as WO/2008/066617; PCT application serial no. PCT/US2008/052845 published as WO/2008/095183; PCT application serial no. PCT/US2008/053999 published as WO/2008/101107; PCT application serial no. PCT/US2008/056296 published as WO/2008/112577; PCT application serial no. PCT/US2008/056299 published as WO/2008/112578; and PCT application serial no. PCT/US2008/077753; the disclosures of which are herein incorporated by reference.

## KITS

Also provided are kits that include one or more IEMs, such as described  
5 above. In those aspects having a plurality of IEMs, the IEMs may be packaged in  
a single container, e.g., a single tube, bottle, vial, and the like, or one or more  
dosage amounts may be individually packaged such that certain kits may have  
more than one container of IEMs. In certain aspects the kits may also include a  
receiver, such as reviewed above. In certain aspects, the kits may also include  
10 an external monitor device, e.g., as described above, which may provide for  
communication with a remote location, e.g., a doctor's office, a central facility etc.,  
which obtains and processes data obtained about the usage of the composition.

The subject kits may also include instructions for how to practice the  
subject methods using the components of the kit. The instructions may be  
15 recorded on a suitable recording medium or substrate. For example, the  
instructions may be printed on a substrate, such as paper or plastic, etc. As  
such, the instructions may be present in the kits as a package insert, in the  
labeling of the container of the kit or components thereof (i.e., associated with the  
packaging or sub-packaging) etc. In other aspects, the instructions are present  
20 as an electronic storage data file present on a suitable computer readable  
storage medium, e.g. CD-ROM, diskette, etc. In yet other aspects, the actual  
instructions are not present in the kit, but means for obtaining the instructions  
from a remote source, e.g. via the internet, are provided. An example of this  
aspect is a kit that includes a web address where the instructions can be viewed  
25 and/or from which the instructions can be downloaded. As with the instructions,  
this means for obtaining the instructions is recorded on a suitable substrate.

Some or all components of the subject kits may be packaged in suitable  
packaging to maintain sterility. In many aspects of the subject kits, the  
components of the kit are packaged in a kit containment element to make a  
30 single, easily handled unit, where the kit containment element, e.g., box or  
analogous structure, may or may not be an airtight container, e.g., to further  
preserve the sterility of some or all of the components of the kit.

It is to be understood that this invention is not limited to particular aspects described, as such may vary. It is also to be understood that the terminology used herein is for the purpose of describing particular aspects only, and is not intended to be limiting, since the scope of the present invention will be limited  
5 only by the appended claims.

Where a range of values is provided, it is understood that each intervening value, to the tenth of the unit of the lower limit unless the context clearly dictates otherwise, between the upper and lower limit of that range and any other stated or intervening value in that stated range, is encompassed within the invention.  
10 The upper and lower limits of these smaller ranges may independently be included in the smaller ranges and are also encompassed within the invention, subject to any specifically excluded limit in the stated range. Where the stated range includes one or both of the limits, ranges excluding either or both of those included limits are also included in the invention.

Unless defined otherwise, all technical and scientific terms used herein have the same meaning as commonly understood by one of ordinary skill in the art to which this invention belongs. Although any methods and materials similar or equivalent to those described herein can also be used in the practice or testing of the present invention, representative illustrative methods and materials are  
15 now described.  
20

All publications and patents cited in this specification are herein incorporated by reference as if each individual publication or patent were specifically and individually indicated to be incorporated by reference and are incorporated herein by reference to disclose and describe the methods and/or  
25 materials in connection with which the publications are cited. The citation of any publication is for its disclosure prior to the filing date and should not be construed as an admission that the present invention is not entitled to antedate such publication by virtue of prior invention. Further, the dates of publication provided may be different from the actual publication dates which may need to be  
30 independently confirmed.

It is noted that, as used herein and in the appended claims, the singular forms "a", "an", and "the" include plural referents unless the context clearly dictates otherwise. It is further noted that the claims may be drafted to exclude any optional element. As such, this statement is intended to serve as antecedent



basis for use of such exclusive terminology as “solely,” “only” and the like in connection with the recitation of claim elements, or use of a “negative” limitation.

As will be apparent to those of skill in the art upon reading this disclosure, each of the individual aspects described and illustrated herein has discrete  
5 components and features which may be readily separated from or combined with the features of any of the other several aspects without departing from the scope or spirit of the present invention. Any recited method can be carried out in the order of events recited or in any other order which is logically possible.

Although the foregoing invention has been described in some detail by  
10 way of illustration and example for purposes of clarity of understanding, it is readily apparent to those of ordinary skill in the art in light of the teachings of this invention that certain changes and modifications may be made thereto without departing from the spirit or scope of the appended claims.

Accordingly, the preceding merely illustrates the principles of the invention.  
15 It will be appreciated that those skilled in the art will be able to devise various arrangements which, although not explicitly described or shown herein, embody the principles of the invention and are included within its spirit and scope. Furthermore, all examples and conditional language recited herein are principally intended to aid the reader in understanding the principles of the invention and the  
20 concepts contributed by the inventors to furthering the art, and are to be construed as being without limitation to such specifically recited examples and conditions. Moreover, all statements herein reciting principles, aspects, and aspects of the invention as well as specific examples thereof, are intended to encompass both structural and functional equivalents thereof. Additionally, it is  
25 intended that such equivalents include both currently known equivalents and equivalents developed in the future, i.e., any elements developed that perform the same function, regardless of structure. The scope of the present invention, therefore, is not intended to be limited to the exemplary aspects shown and described herein. Rather, the scope and spirit of present invention is embodied  
30 by the appended claims.

WHAT IS CLAIMED IS:

1. A device comprising:  
5           an ingestible event marker to communicate a current signature; and  
            an ingestible component physically associated with the ingestible event  
marker.
2.     The device of Claim 1, wherein the ingestible component comprises an  
10    osmotic ingestible component.
3.     The device of Claim 2, wherein the osmotic ingestible component  
comprises a semipermeable layer and an osmotic member.
- 15    4.     The device of Claim 2, wherein the osmotic ingestible component is a  
tablet.
5.     The device of Claim 2, wherein the osmotic ingestible component is an  
osmotic capsule comprising:  
20           an outer semi-permeable layer forming a passageway; and  
            an osmotic member physically associated with the outer semi-permeable  
layer.
6.     The device of Claim 3, wherein the osmotic member is physically  
25    associated with the ingestible event marker.
7.     The device of Claim 6, wherein the ingestible event marker is configured  
as a barrier that separates the osmotic member from an active agent composition  
present in the osmotic capsule.  
30
8.     The device of Claim 5, wherein at least one ingestible event marker is  
stably associated with an outer location of the osmotic capsule.

9. The device of Claim 8, wherein the osmotic capsule is configured such that each of the at least one ingestible event marker is activated when the respective ingestible event marker is approximately level with the osmotic member.

5

10. The device of Claim 1, wherein the ingestible component comprises:  
a liquid capsule comprising:  
a shell; and  
a liquid medium present in the shell.

10

11. The device of Claim 10, wherein the ingestible event marker is in physical communication with the liquid medium.

12. The device of Claim 11, further comprising a coating physically associated with the ingestible event marker to protect the ingestible event marker from the liquid medium.

13. The device of Claim 12, wherein the coating comprises a pH sensitive coating.

20

14. The device of Claim 1, wherein the ingestible component further comprises a vesicle and wherein the ingestible event marker is physically present in the vesicle.

25 15. The device of Claim 10, further comprising an encasing liquid to encase the ingestible event marker, wherein the encasing liquid is immiscible with the liquid medium.

30 16. The device of Claim 10, wherein the shell comprises a sealed compartment to house the ingestible event marker.

17. The device of Claim 10, wherein the ingestible event marker is integrated with the shell.

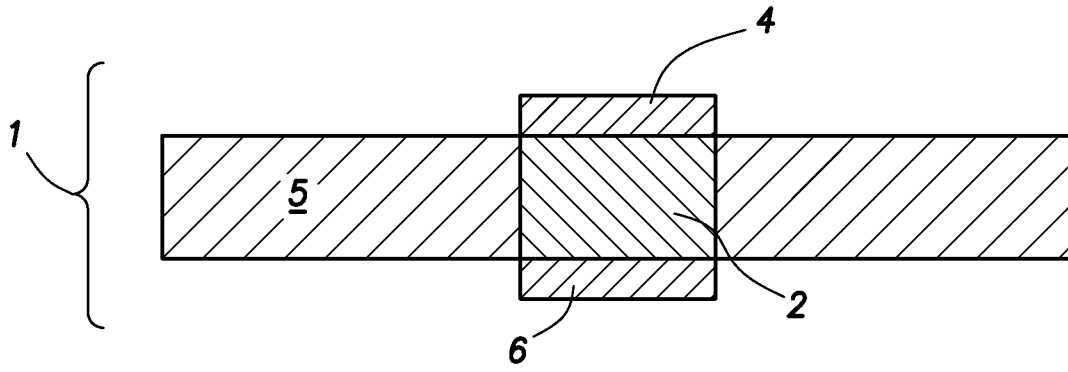
18. A system comprising:  
a device comprising:  
an ingestible event marker to communicate a current signature; and  
5 an ingestible component physically associated with the ingestible  
event marker; and  
a receiver to detect the communicated current signature.

19. The system of Claim 18, wherein the ingestible component comprises  
10 an osmotic ingestible component.

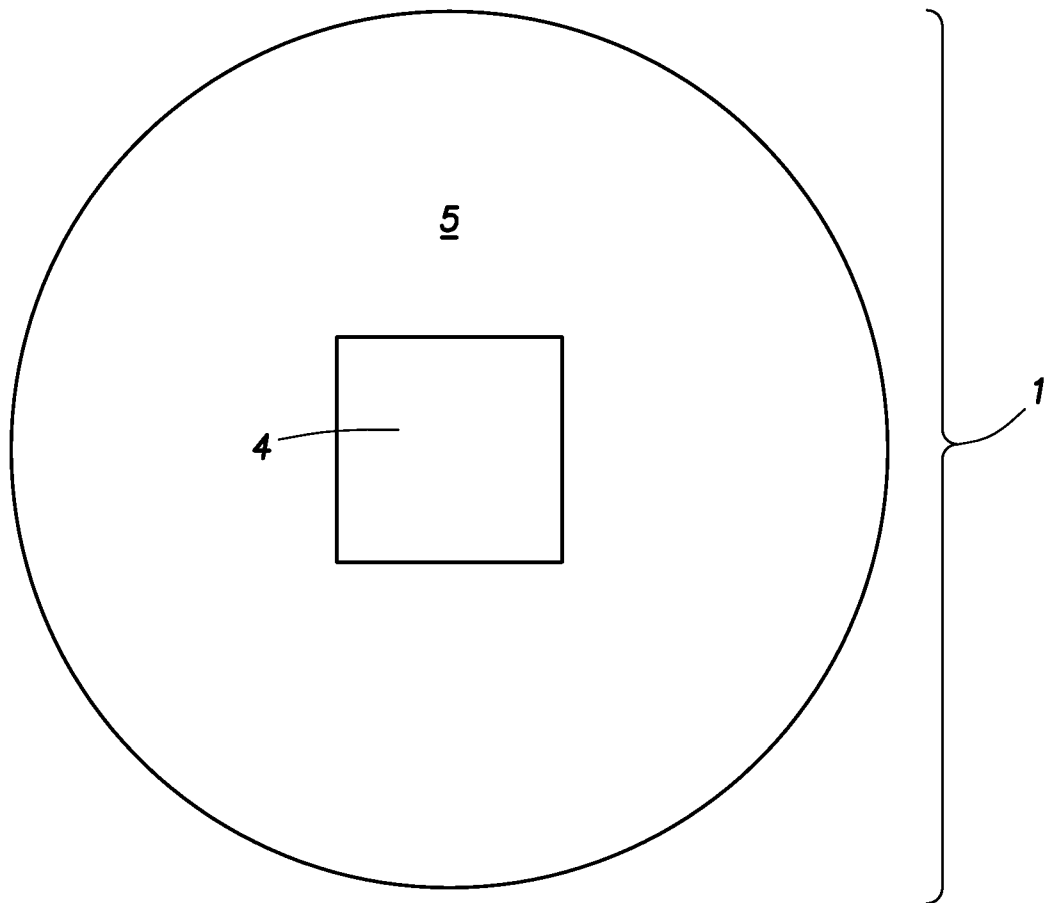
20. The system of Claim 18, wherein the ingestible component comprises:  
a liquid capsule comprising:  
a shell; and  
15 a liquid medium present in the shell.

20

25



**FIG. 1A**



**FIG. 1B**

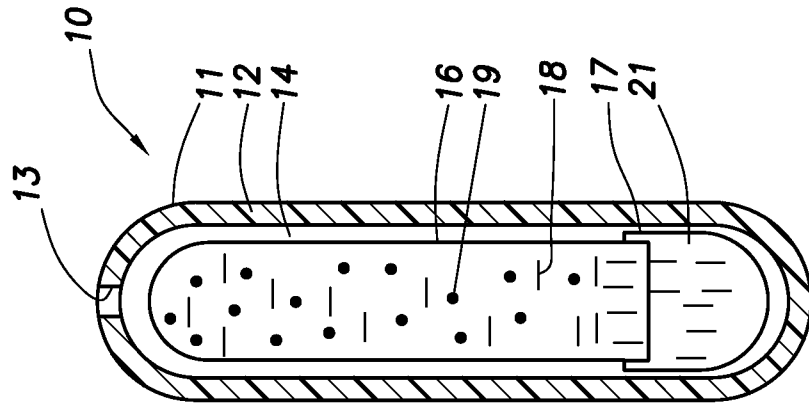


FIG. 2B

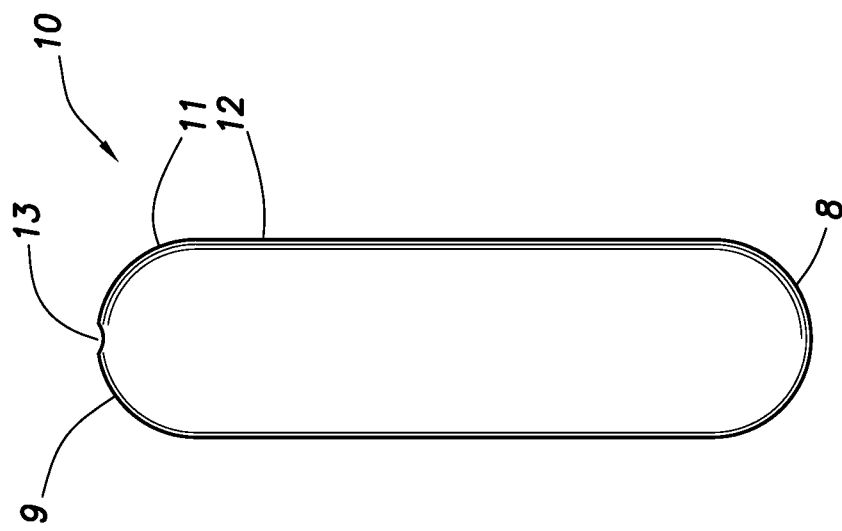


FIG. 2A

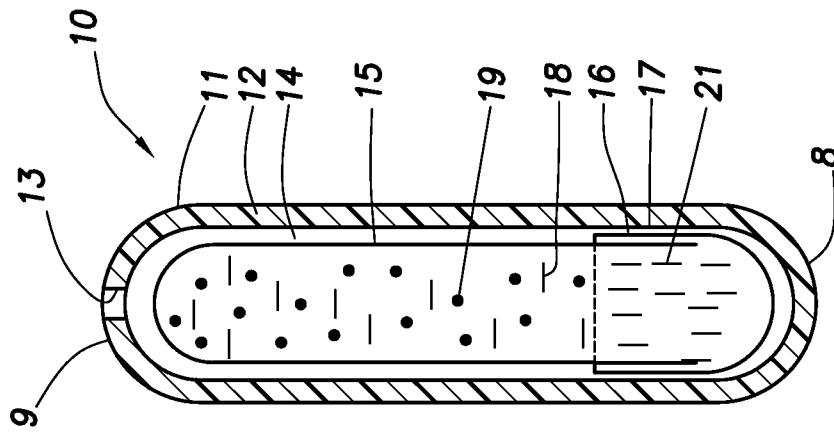


FIG. 2D

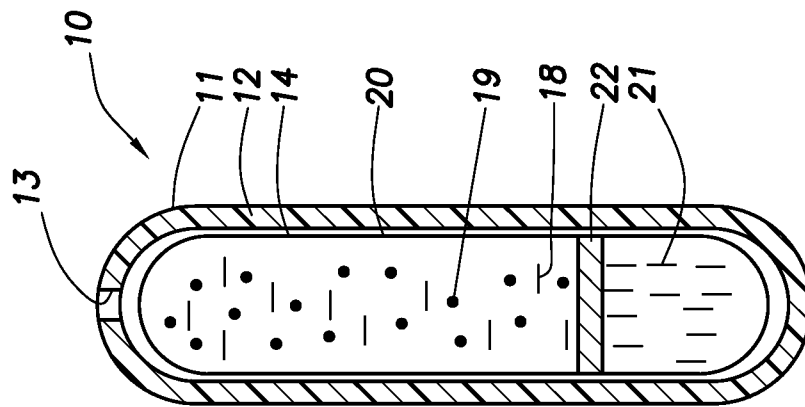


FIG. 2C

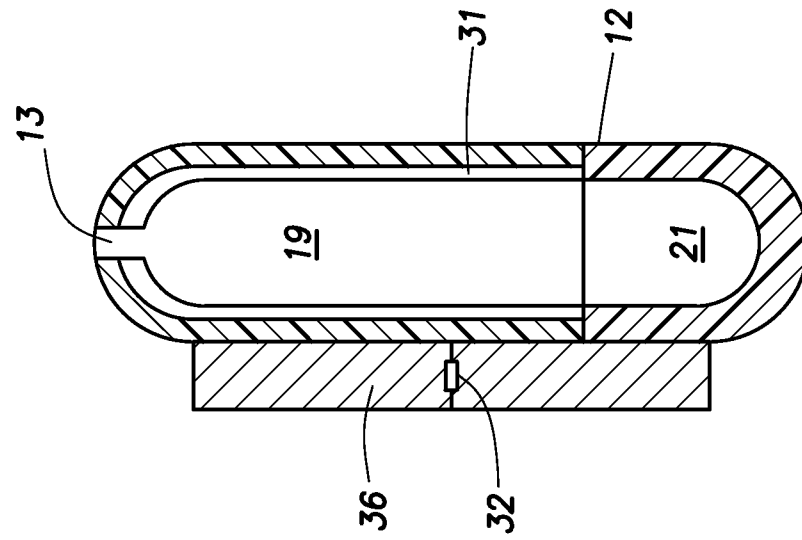


FIG.4

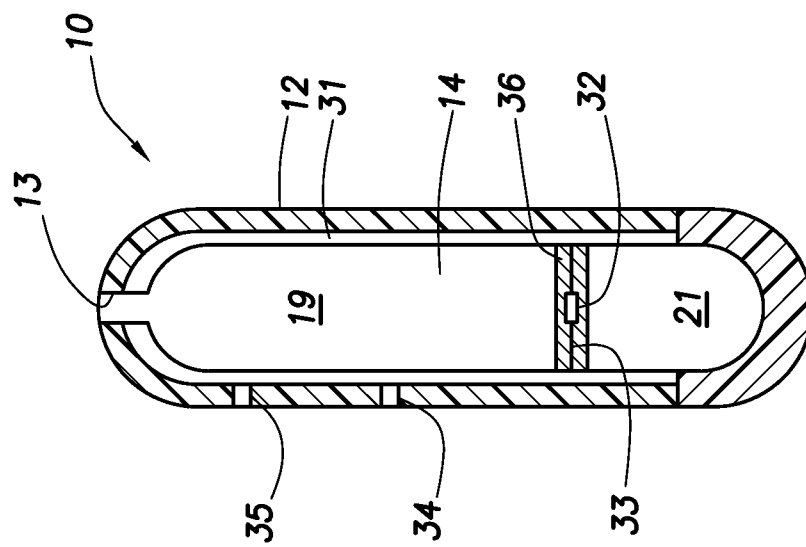


FIG.3



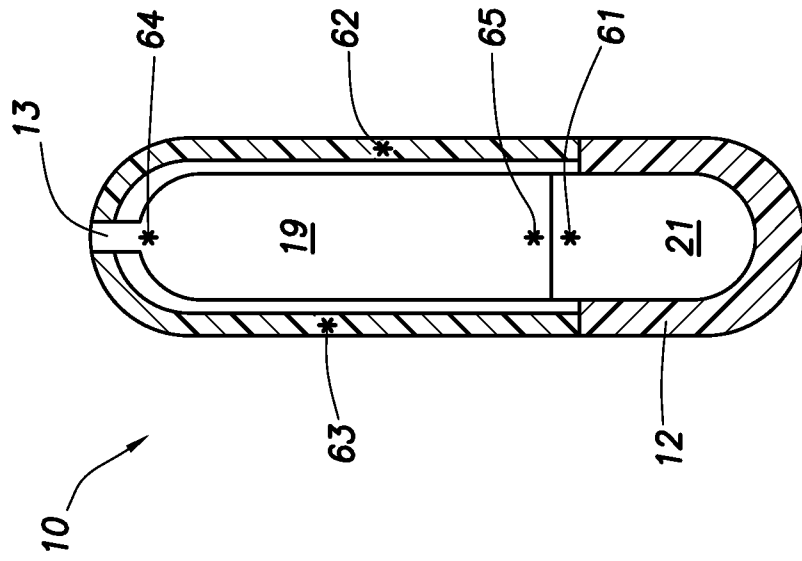


FIG. 6

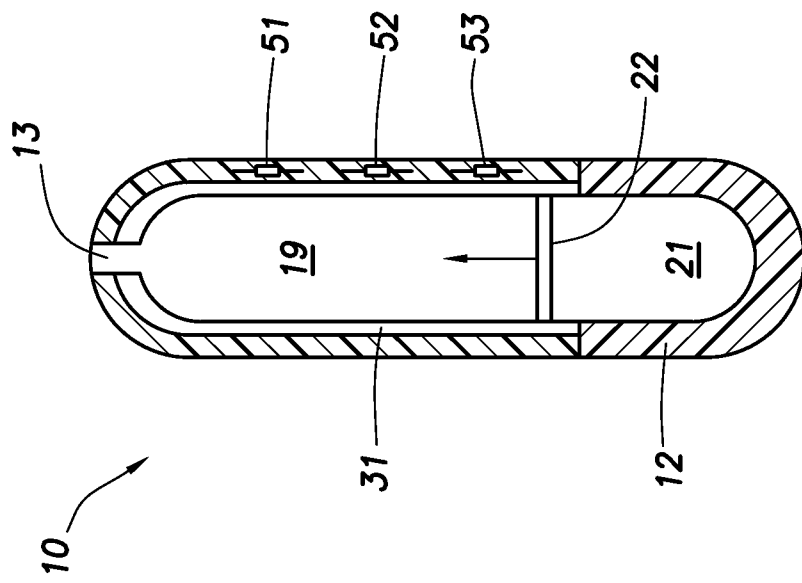


FIG. 5

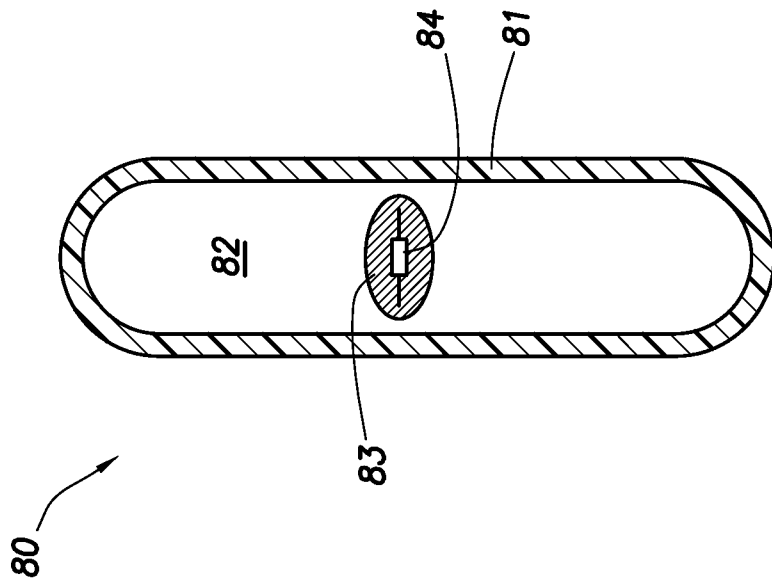


FIG. 8

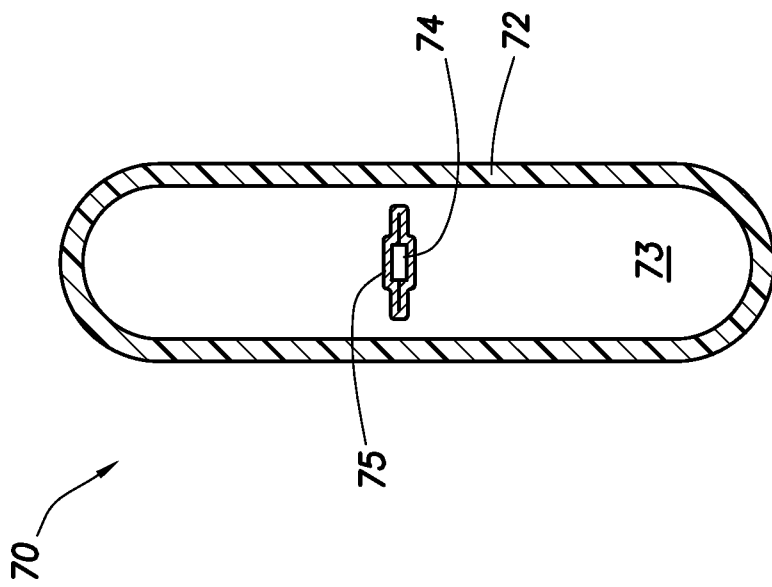


FIG. 7

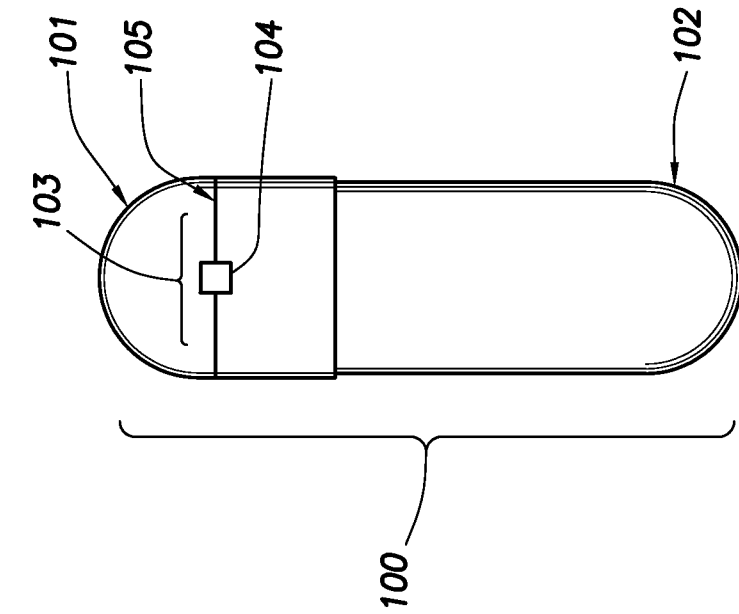


FIG. 10A

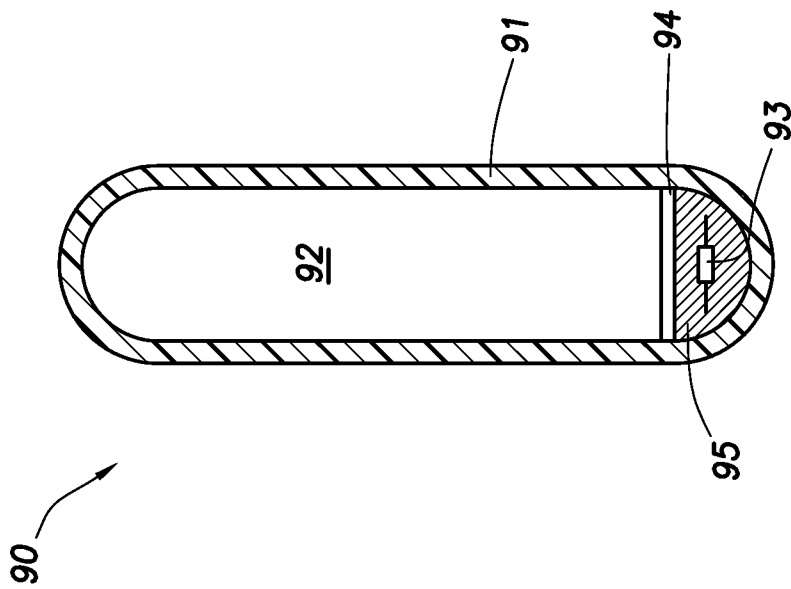
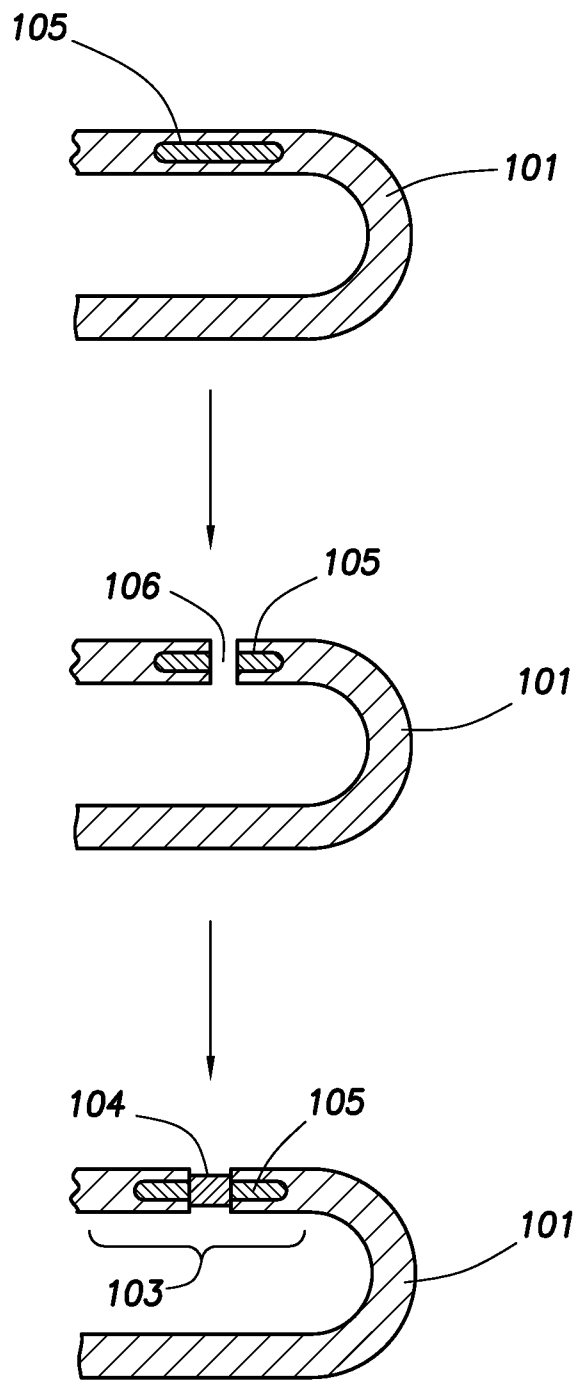


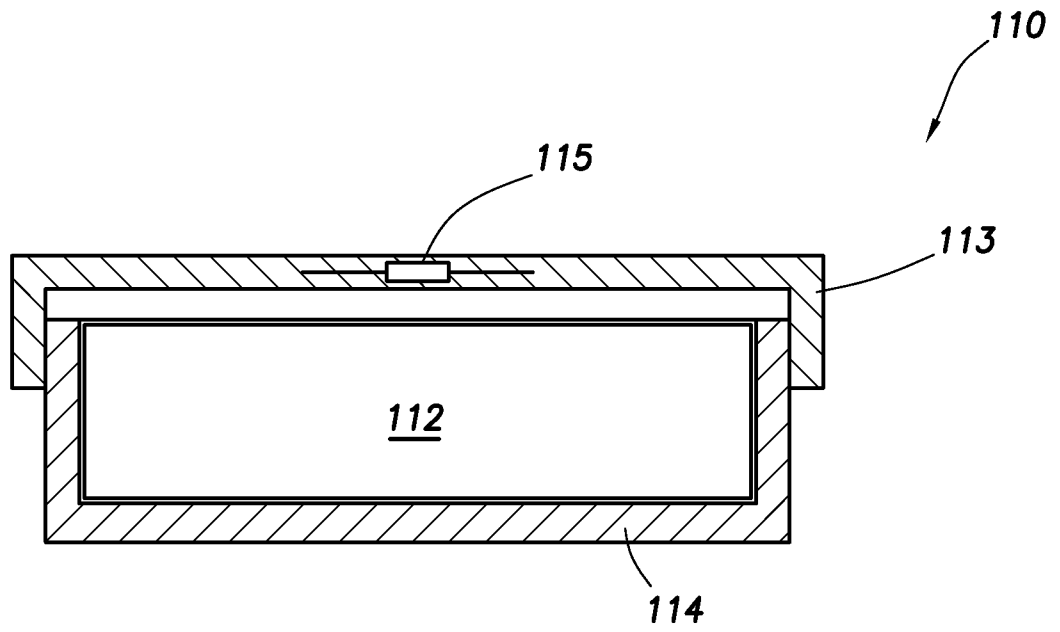
FIG. 9

8/10

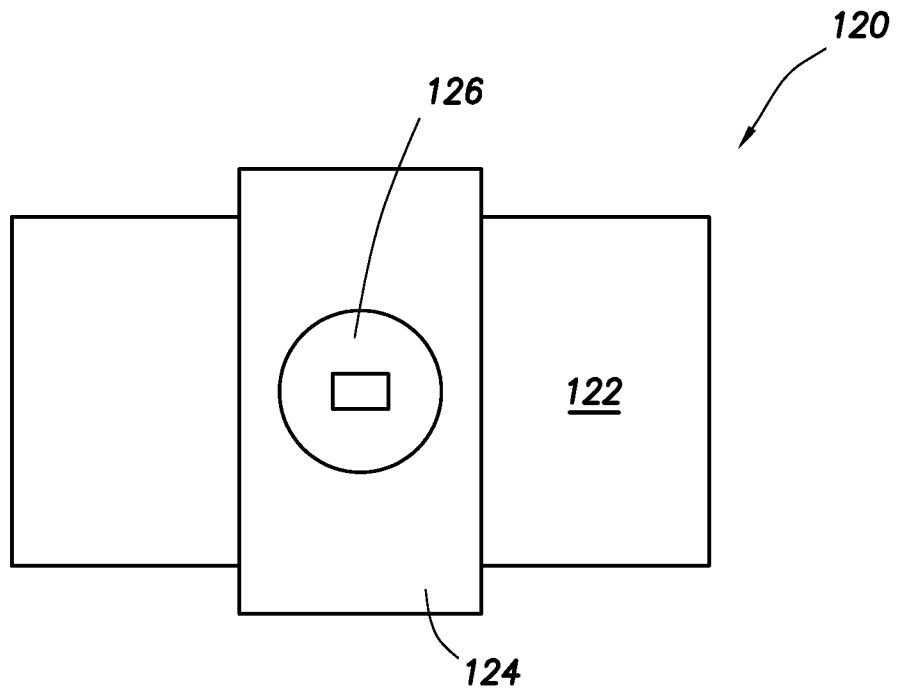


**FIG. 10B**

9/10

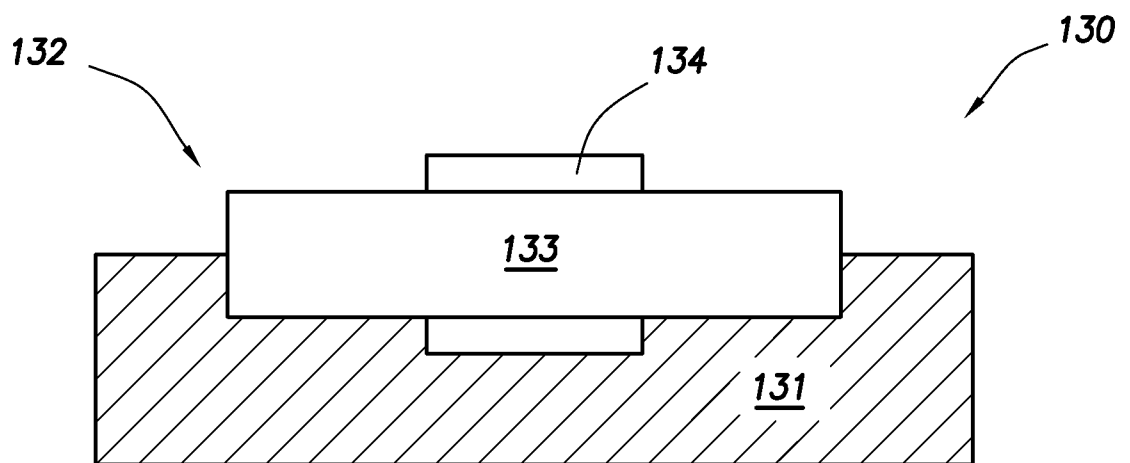
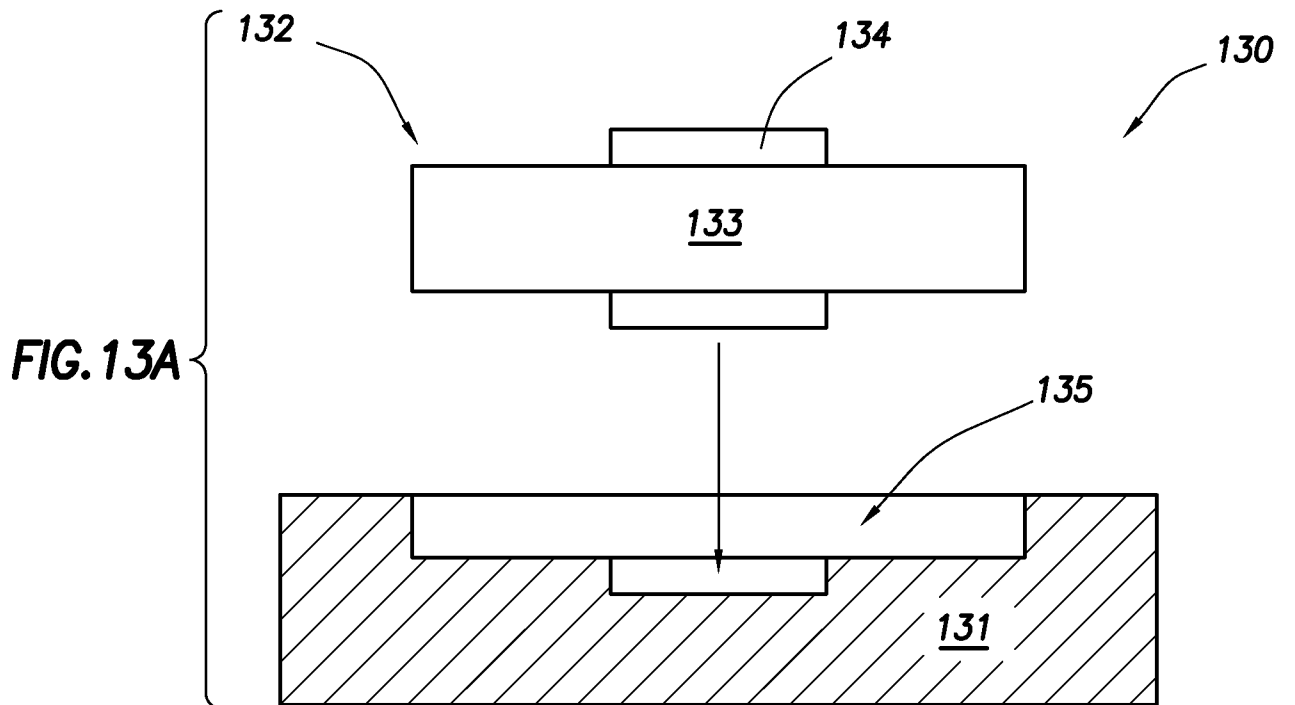


**FIG.11**



**FIG.12**

10/10



**FIG. 13B**