

(No Model.)

2 Sheets—Sheet 1.

C. W. BARRETT.
LEMON SQUEEZER.

No. 492,259.

Patented Feb. 21, 1893.

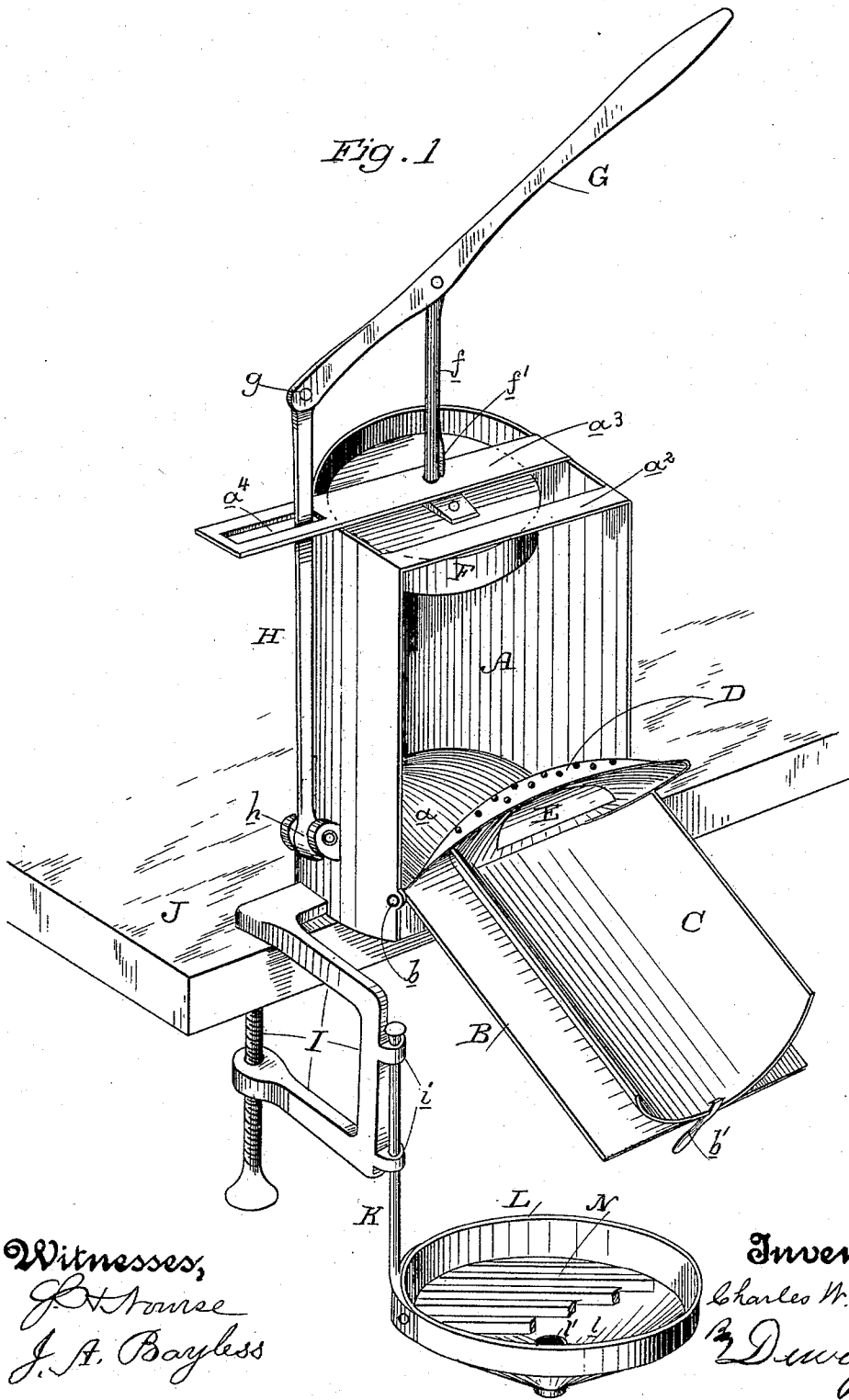

Witnesses,
J. H. Hourse
J. A. Bayless

Inventor,
Charles W. Barrett
B. Dewey & Co., atty's

C. W. BARRETT.
LEMON SQUEEZER.

No. 492,259.

Patented Feb. 21, 1893.

Fig. 2

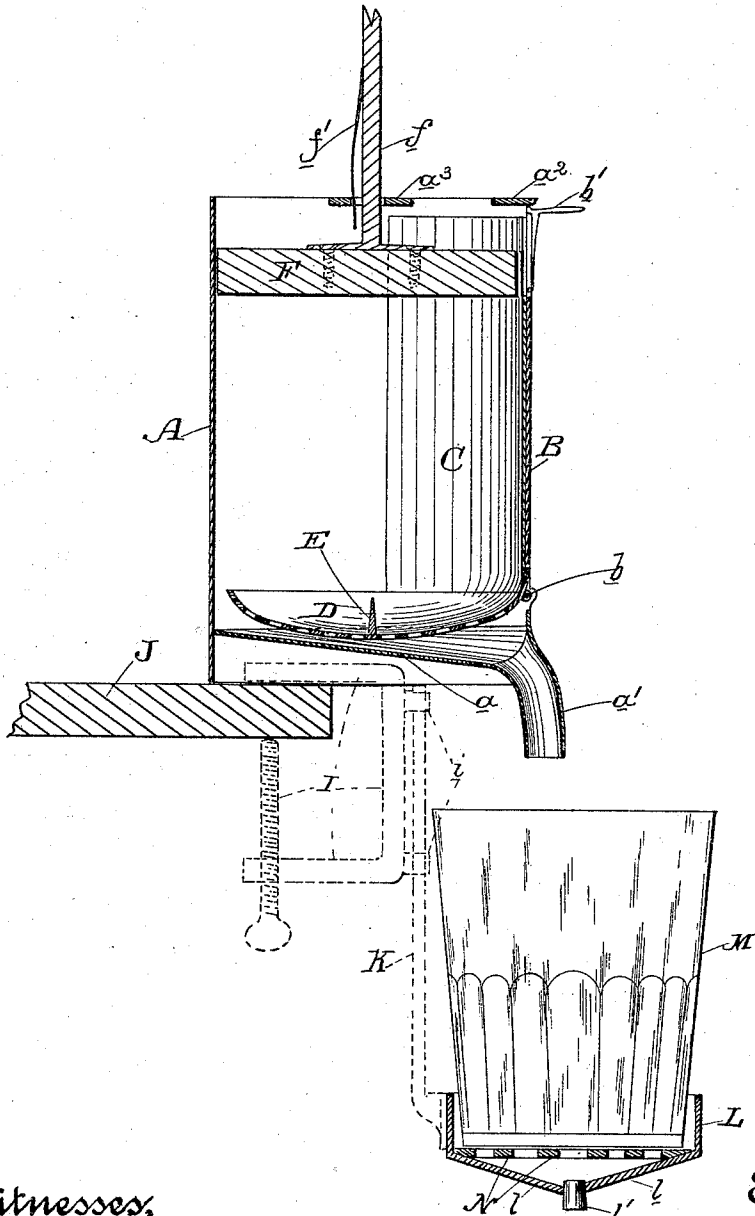

Witnesses,
St. Anouse
J. A. Bayless

Inventor,
Charles W. Barrett
By Dewey & Co.
attys

UNITED STATES PATENT OFFICE.

CHARLES W. BARRETT, OF LEMOORE, CALIFORNIA.

LEMON-SQUEEZER.

SPECIFICATION forming part of Letters Patent No. 492,259, dated February 21, 1893.

Application filed October 26, 1892. Serial No. 459,075. (No model.)

To all whom it may concern:

Be it known that I, CHARLES W. BARRETT, a citizen of the United States, residing at Lemoore, Tulare county, State of California, have invented an Improvement in Lemon-Squeezers; and I hereby declare the following to be a full, clear, and exact description of the same.

My invention relates to that class of lemon squeezers in which a vertically movable plunger operates within a cup containing a strainer upon which the lemon rests, said cup being provided with a discharge aperture adapted to convey the juice into an underlying tumbler.

My invention consists essentially in an open front cup provided with a vertically swinging front plate adapted to open and close the cup, said swinging plate carrying the strainer which is moved into and out of the cup by the swinging of said plate.

It also consists in the several constructions and arrangements of parts which I shall hereinafter fully describe and specifically point out in the claims.

The object of my invention is to provide a simple, effective, and easily handled lemon squeezer, the particular advantage of which is that by a simple and rapid movement the lemon may be inserted to be squeezed, and may be discharged after the plunger has compressed it.

Referring to the accompanying drawings for a more complete explanation of my invention,—Figure 1 is a perspective view of my lemon squeezer, the swinging plate being shown open and in position to discharge the squeezed lemon. Fig. 2 is a vertical section of my lemon squeezer, showing the swinging plate closed and the parts in position ready to squeeze the lemon.

A is a cup having an inclined draining bottom a which terminates in a discharge spout a' . The general shape of this cup, in cross section, is preferably that shown in Fig. 1, wherein it will be seen that the back of the cup is substantially circular, and its sides project forwardly in approximately straight and parallel planes, and leave the whole front of the cup open. To the lower portions of the forward edges of these sides is horizontally hinged, as shown at b , the swinging front plate B which is adapted to swing through a vertical

are to open and close the cup. The top of the plate is provided with a small catch b' which is adapted to engage a cross bar a^3 on the top front of the cup, and to be released therefrom, whereby the front plate may be held in a vertical position to close the cup as in Fig. 2, and released to be allowed to fall to a downwardly inclined position, as shown in Fig. 1.

To the inside of the plate B is secured a curved plate C having such a curvature as will adapt it, when the plate B is raised to a vertical position, to complete the curvature of the back of the cup A thereby forming within the cup a substantially circular chamber.

To the lower portion of the swinging front plate B is secured the strainer D of the usual dish shape, and adapted, when the front plate is raised to a vertical position, as in Fig. 2, to traverse the base of the cup, and when the front plate is in a downwardly inclined position to be sufficiently inverted, as shown in Fig. 1, to discharge the lemon contained within it. In this strainer may be secured a cross knife E.

F is the pressing plunger fitted and adapted to move up and down in the circular chamber of the cup. It is provided with a stem f which rises through a cross-bar a^3 on the top of the cup, and the top of said stem is pivoted to an operating lever G. The end of this lever is pivoted at g to a vibrating fulcrum link H, the lower end of which is pivoted at h to the lower portion of the cup A, and said link is guided in an elongated slot a^4 in the end of the cross-bar a^3 . This construction, by having the movable or vibrating fulcrum link, permits the true vertical movement of the plunger without cramping.

In order to hold the plunger up, there is a small friction spring f' secured to the side of the stem f and which plays down through the cross-bar a^3 . This spring does not prevent the stem from moving up and down under the pressure applied to the handle G, but is sufficient to so bind upon the cross-bar a^3 as to hold the plunger up during the discharge of the squeezed lemon and the placing of a fresh one in the strainer.

To the base of the cup A is secured the screw clamp bracket I by which the whole device is adapted to be clamped upon the edge of a table J or other support. In suitable bearings i on the front of this bracket is pivotally mounted

the axially turnable hanger K, to the lower end of which is secured the support L for the tumbler M. This support has a concave bottom *l* provided with a plugged aperture *l'*, and upon the interior of said support is fitted a draining platform N upon which the tumbler M rests. By the movement of the hanger K in its bearings the tumbler can be turned under the discharge spout *a'* of the cup A and removed to one side thereof.

The operation of my lemon squeezer is as follows:—When the parts are in the position shown in Fig. 1, with the swinging front plate B fully open, the lemon, or part of the lemon as the case may be, is placed upon the knife E in the strainer. The front plate B is then raised to a vertical position, as shown in Fig. 2, and is there held, and in this position it will be seen that the strainer lies wholly within the cup and supports the lemon directly under the plunger F. The lever G is now pressed down, whereby the plunger F descends and presses the lemon in the strainer, and the juice passes through said strainer on to the inclined drain bottom *a* from which it flows into the discharge spout *a'* and thence into the tumbler. The lever G is then raised, whereby the plunger F is fully elevated, and thereupon the operator, with his free hand, releases the catch *b'*, turns the front plate B outwardly and downwardly to an inclination as shown in Fig. 1, and the squeezed lemon thereupon by its own weight, will fall from the strainer and roll along the plate C either into the hand of the operator or into a suitable receptacle. A fresh lemon is then placed in position, the front plate B is raised and locked, and the operation is repeated. In this way the lemons may be squeezed rapidly, and each discharged, after being squeezed, in the most convenient manner.

The drain platform N in the support L provides for the disposal of any drip from the spout *a'* after the tumbler M is removed and this drip may be saved by removing the plug *l'*. The drain platform N thus presents a clean surface for the bottom of the glass at all times.

Having thus described my invention, what I claim as new, and desire to secure by Letters Patent, is—

1. A lemon squeezer consisting of a cup having an open front, a horizontally pivoted vertically swinging front plate adapted to close and open said front, a strainer secured to said swinging front plate and adapted by the movement of said plate to be thrown into and out of the cup whereby the lemon is received, is held in position to be squeezed, and is discharged after being squeezed, and a vertically moving plunger operating within said cup, substantially as herein described.

2. A lemon squeezer consisting of a cup having an open front, a vertically swinging front plate adapted to open and close said front, a catch on the top of said front plate adapted to engage the top of the cup to lock it in po-

sition and to release it, a strainer carried by said swinging front plate and adapted by its movements to be thrown into the cup to hold a lemon and to be thrown outwardly to discharge the squeezed lemon, and receive a fresh one, and a vertically moving plunger operating within said cup, substantially as herein described.

3. A lemon squeezer consisting of a cup having an open front, an inclined drain bottom and a discharge spout, a vertically swinging front plate hinged horizontally to the base of the cup and adapted to open and close the open front thereof, a strainer secured to said front plate and adapted by its movement to be thrown into and out of the cup, and a plunger operating within the cup, substantially as herein described.

4. A lemon squeezer consisting of a cup having an open front, a horizontally pivoted vertically swinging front plate fitted to said open front and adapted to open and close it, a strainer carried by said swinging front plate whereby it is thrown into and out of the cup, a knife carried by the strainer and a vertically moving plunger operating in the cup, substantially as herein described.

5. A lemon squeezer consisting of a cup having a curved back and separated straight sides leaving an open front, a horizontally pivoted vertically swinging front plate fitted to the open front of the cup, a curved plate carried on the inner surface of said front plate and adapted to complete the circular chamber of the cup, a strainer carried by said front plate and adapted to be moved into and out of the cup and a vertically movable plunger operating in the cup, substantially as herein described.

6. A lemon squeezer consisting of a cup having an open front, a horizontally pivoted vertically moving front plate fitted to and adapted to open and close said front, a strainer carried by said front plate and adapted by its movement to be moved into and out of the cup, a plunger within the cup and having a stem, a lever pivoted to the upper end of said stem, and a vibrating fulcrum link to which said lever is secured, substantially as herein described.

7. A lemon squeezer consisting of the open front cup, the swinging front plate pivoted thereto, the strainer carried by said front plate, the vertically movable plunger operating within the cup, the clamp bracket by which said cup is carried, the axially movable hanger secured to said bracket, the tumbler support carried by said hanger and having a draining bottom, and a drain platform within said support above its bottom, substantially as herein described.

In witness whereof I have hereunto set my hand.

CHARLES W. BARRETT.

Witnesses:

S. H. NOURSE,

J. A. BAYLESS.