

No. 885,803.

PATENTED APR. 28, 1908.

E. F. TERRY.
COLLAPSIBLE WRECKING DERRICK AND CAR.

APPLICATION FILED DEC. 24, 1907.

6 SHEETS—SHEET 1.

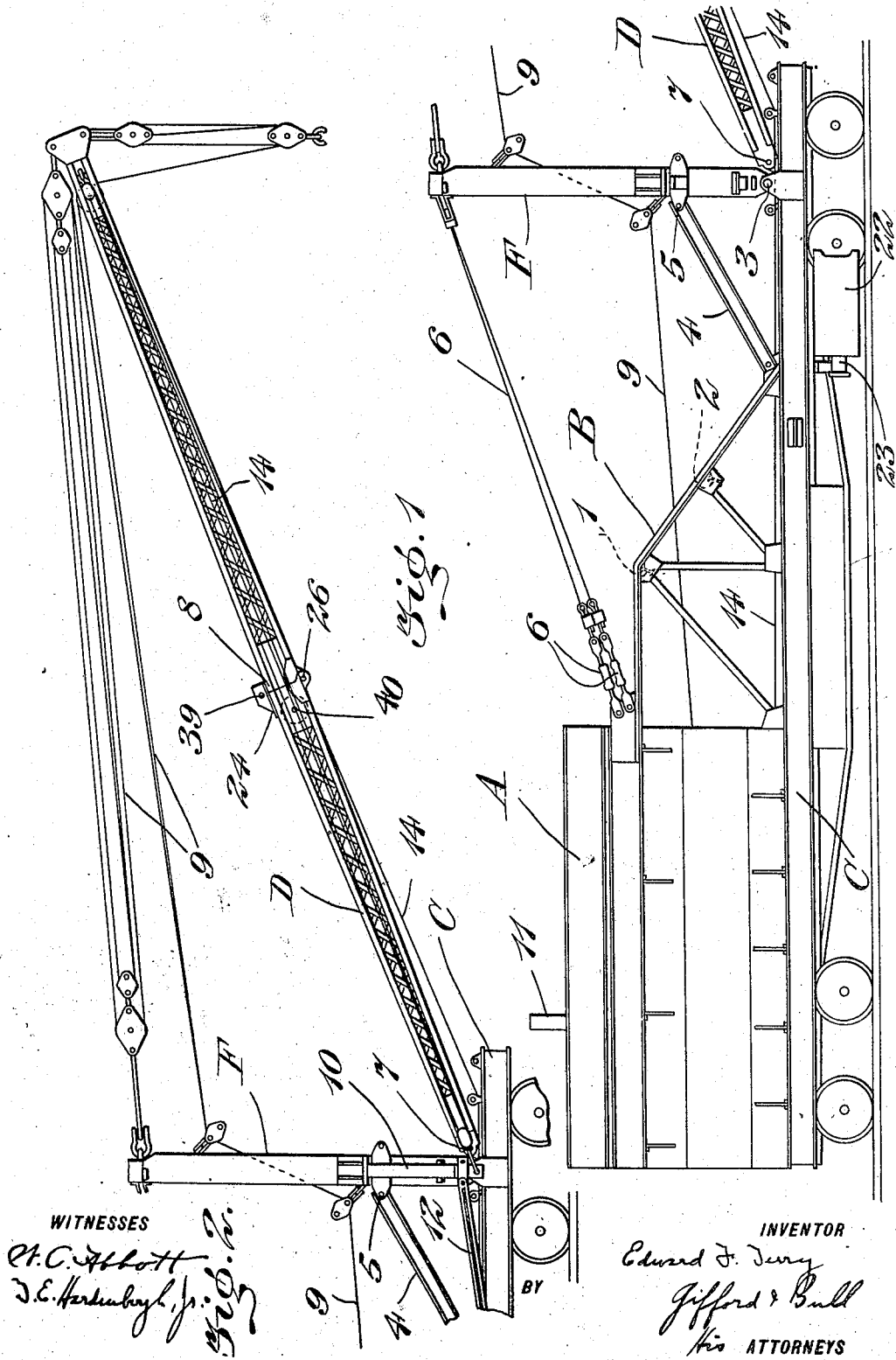

WITNESSES
C. C. Abbott
J. E. Harkness, Jr.
5/10/07

INVENTOR
Edward F. Terry
BY
Gifford & Bull
ATTORNEYS

No. 885,803.

PATENTED APR. 28, 1908.

E. F. TERRY.
COLLAPSIBLE WRECKING DERRICK AND CAR.

APPLICATION FILED DEC. 24, 1907.

6 SHEETS—SHEET 2.

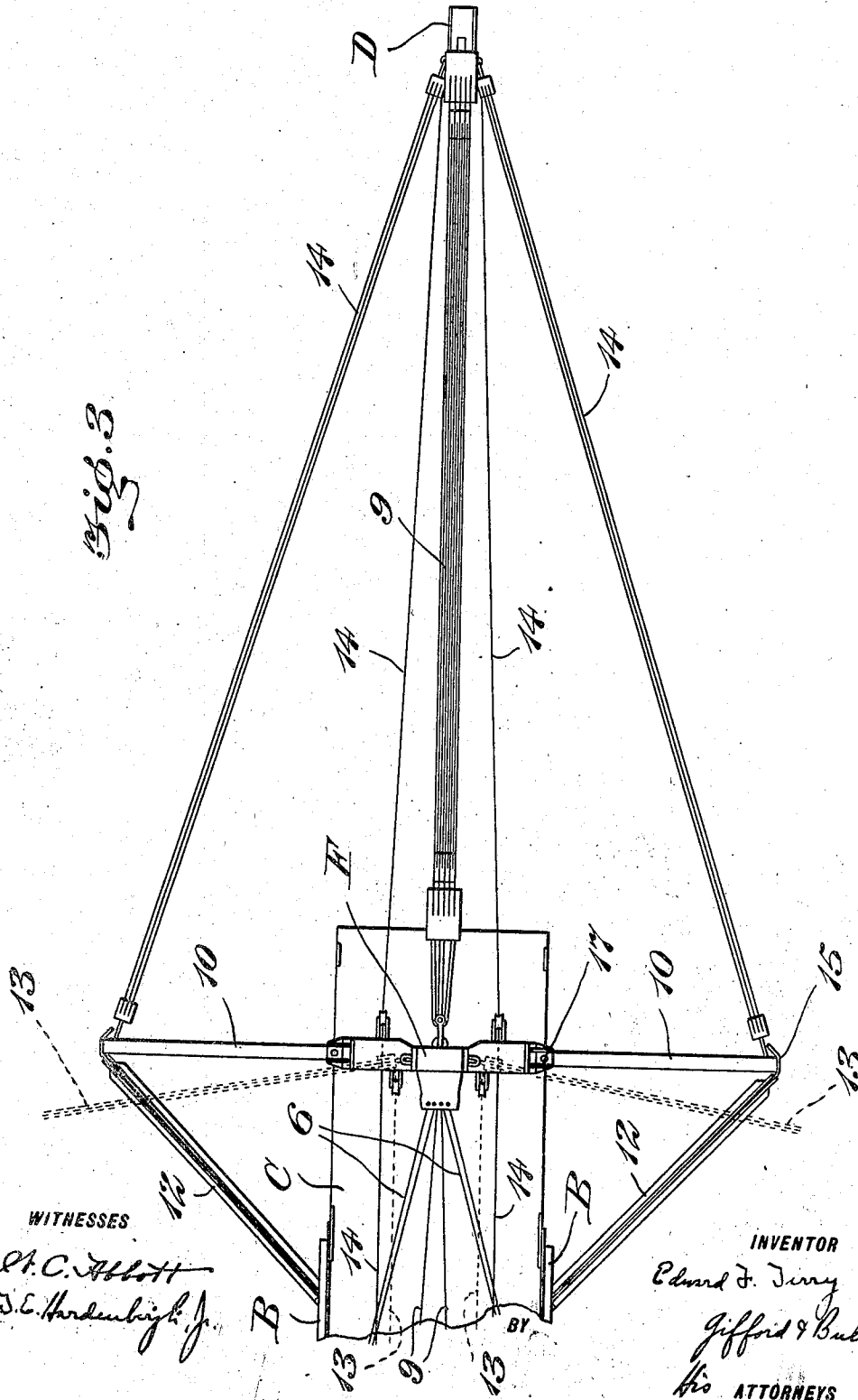

Fig. 3

WITNESSES

A. C. Abbott
J. E. Hardenbrygh, Jr.

INVENTOR

Edward F. Terry
Gifford & Bull
his ATTORNEYS

E. F. TERRY.
COLLAPSIBLE WRECKING DERRICK AND CAR.

APPLICATION FILED DEC. 24, 1907.

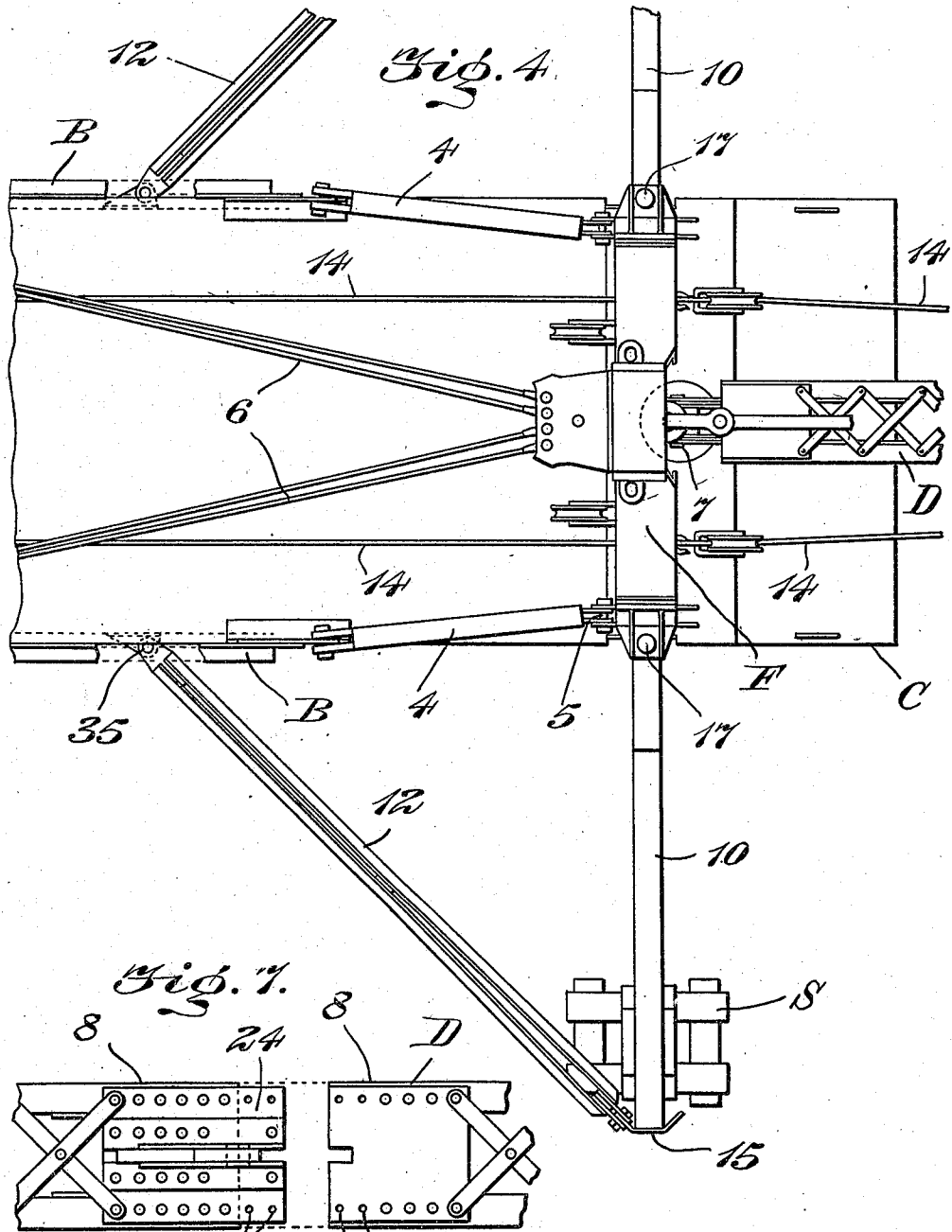

WITNESSES
W. C. Abbott
J. E. Hardenbergh, Jr.

INVENTOR
Edward F. Terry
 BY *Gifford & Bull*
 HIS ATTORNEYS

No. 885,803.

PATENTED APR. 28, 1908.

E. F. TERRY.

COLLAPSIBLE WRECKING DERRICK AND CAR.

APPLICATION FILED DEC. 24, 1907.

6 SHEETS—SHEET 4.

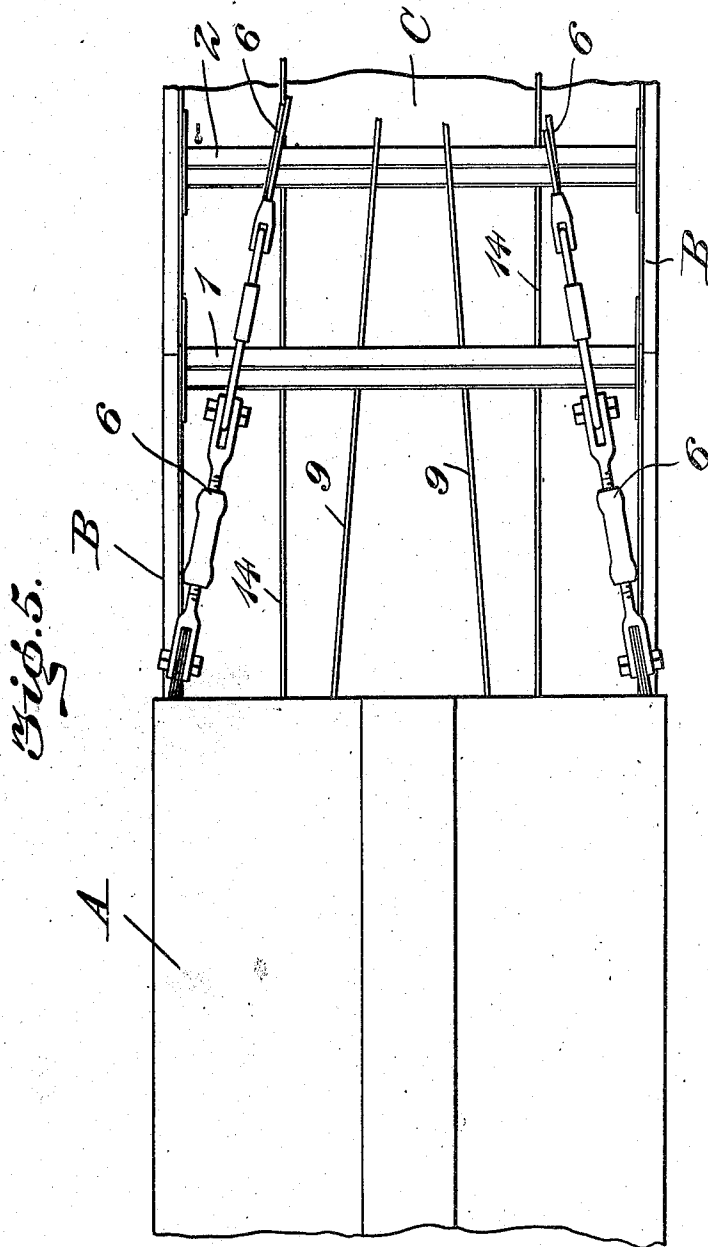

WITNESSES

P. C. Abbott
J. E. Hardinbaugh, Jr.

INVENTOR

Edward F. Terry
BY *Gifford & Bull*
his ATTORNEYS

No. 885,803.

PATENTED APR. 28, 1908.

E. F. TERRY.

COLLAPSIBLE WRECKING DERRICK AND CAR.

APPLICATION FILED DEC. 24, 1907.

6 SHEETS—SHEET 5.

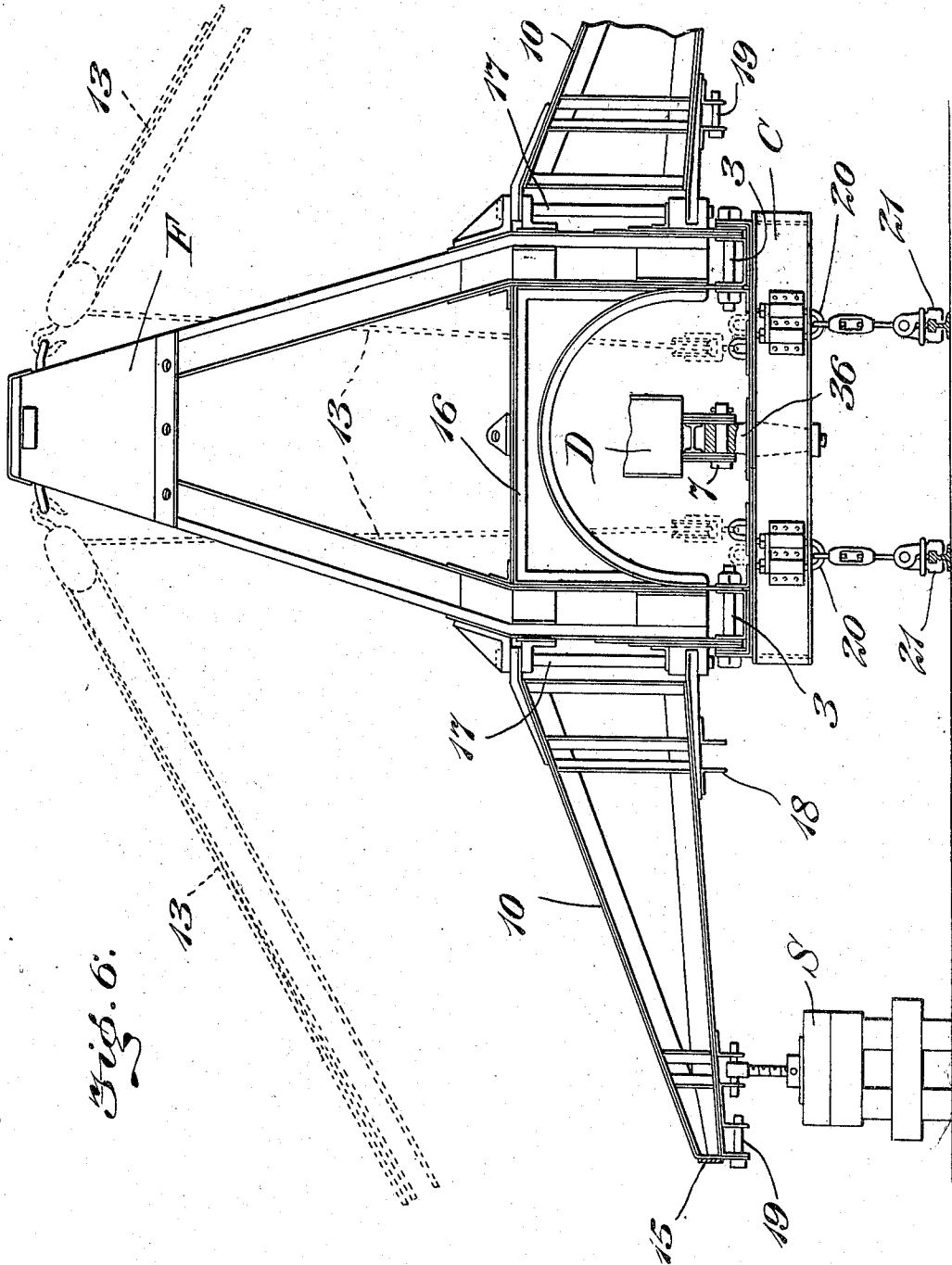

Fig. 6.

WITNESSES

W. C. Abbott
J. E. Hardenburgh, Jr.

INVENTOR

Edward F. Terry
Gifford & Bull
His ATTORNEYS

BY

No. 885,803.

PATENTED APR. 28, 1908.

E. F. TERRY.

COLLAPSIBLE WRECKING DERRICK AND CAR.

APPLICATION FILED DEC. 24, 1907.

6 SHEETS—SHEET 6.

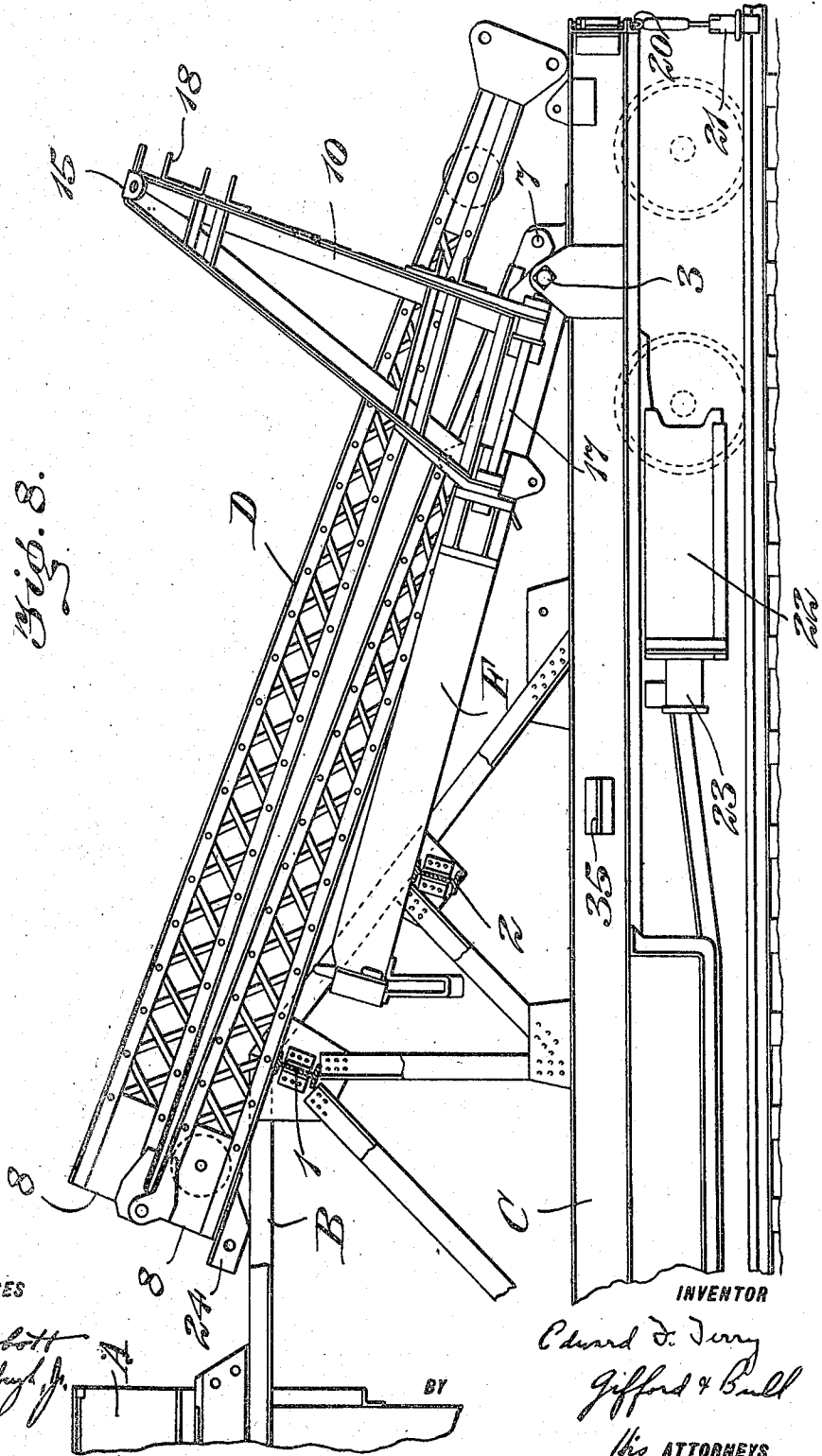

Fig. 8.

WITNESSES

R. C. Abbott
J. E. Hardenburgh, Jr.

BY

INVENTOR

Edward F. Terry
Gifford & Bull

Attorneys

UNITED STATES PATENT OFFICE.

EDWARD F. TERRY, OF NEW YORK, N. Y.

COLLAPSIBLE WRECKING DERRICK AND CAR.

No. 885,803.

Specification of Letters Patent.

Patented April 28, 1908.

Application filed December 24, 1907. Serial No. 407,939.

To all whom it may concern:

Be it known that I, EDWARD F. TERRY, a citizen of the United States, and a resident of the city of New York, borough of Manhattan, in the county and State of New York, have invented certain new and useful improvements in a Collapsible Wrecking Derrick and Car, of which the following is a specification.

It is the purpose of my invention to provide a collapsible wrecking derrick embodying the features of simplicity and strength of construction, ease of operation, and stability under working strains; adapted to be mounted on a car and in all its parts to be collapsed or folded down upon the car in such a manner that the car with the derrick collapsed may pass through tunnels and under bridges constructed to permit of the passage of railroad vehicles of the usual types. An additional advantage is secured through the fact that my improved derrick may be collapsed or folded without necessitating the removal of the derrick rigging, there being a resultant gain in the ease and rapidity with which the derrick may be prepared for removal to a new place of operation and set up after such removal.

By means of the system of braces, and outriggers and the disposition of weight, as hereafter set forth, my improved derrick may be used for the handling of loads of a weight limited only by the strength of the component parts of which the derrick is constructed, and located in any position adjacent that of the derrick structure.

In the application of my invention to the construction of a wrecking derrick and car I have shown a form suitable for the attainment of the advantages as above set forth and at present preferred by me, but various modifications in design and construction of parts may be made without departing from the spirit of my invention as set forth in and falling within the scope of the claims hereto appended.

In the accompanying drawings like characters of reference denote like parts in all the figures thereof.

Figure 1 represents a view in side elevation of the derrick car with derrick frame, the boom being broken off near the foot; Fig. 2 represents a view in side elevation of one end of the car and of the derrick frame and boom; Fig. 3 represents a top plan view of the derrick, frame and rigging; Fig. 4 represents

a top plan view in detail of the derrick frame, foot of boom and rigging; Fig. 5 represents a top plan view of a portion of the car and rigging being a continuation of Fig. 4; Fig. 6 represents a view in end elevation of one end of the car, showing derrick frame, outriggers, and track clamps; Fig. 7 represents a detail top view of the hinged portion of the boom; Fig. 8 represents a view in side elevation of one end of the car with the derrick frame, boom, and outriggers folded or collapsed.

Turning now to a description of my invention in detail, for the purpose of clearness, I will first consider the various parts of my improved structure in connection with Figs. 1 to 6 inclusive. Reference character C denotes the car body of any desired construction (Fig. 1) and provided with driving mechanism (to be hereafter described) inclosed in a casing 22 provided with a suitable inlet 23 for the purpose of connecting the driving mechanism with the boiler of the derrick engine. The driving mechanism is preferably located adjacent one of the car axles on the derrick end of the car for the purpose of giving increased stability to that end by reason of the added weight. Secured to eyes 20 attached to the derrick end of the car (Fig. 6) are clamping members 21 adapted to clamp over the track rails and prevent the raising of the sides of the car upon the operation of the derrick to raise a load from either side of the track. Upon the car body at one end is placed the derrick engine house A (Fig. 1) of such a height as to permit of the passage of the car through tunnels and under bridges, the engine stack 11 being removable. From the inner end of the engine house on each side of the car there extends an angular supporting frame B (Fig. 1); these frames are connected at their points of angle and adjacent the centers of their sloping portions by beams 1 and 2 respectively (Fig. 5). The derrick A-frame F is located at the end of the car opposite the engine house; the vertical portions of the legs of the A-frame being connected by an arched strengthening member 16 (Fig. 6). The foot of each leg of the A-frame is pivoted on a bolt 3 passing through plates secured to and projecting below the bottom of the foot, and flanges on plates secured to the car. Each leg of the A-frame is provided with a pair of flange members 5 located on the vertical portion thereof (Figs. 1 and 4); to these flanges is removably secured

the end of a brace beam 4 which slopes downward and is removably secured at its other end to the car, preferably to a plate, secured thereto, which may also be adapted to support the end of the sloping portion of the frame B. An auxiliary brace may also be used extending to the car from the A-frame on the side opposite to brace 4. Secured to the top of the A-frame, on the innerside, are guys 6 diverging and secured to plates projecting one from each side of the engine house above the frame B (Figs. 1, 4 and 5).

Pivoted on bolts 17 passing through bearings on the outer side of the vertical portion of each leg of the A frame, are side supports or outriggers 10, the bolts 17 also passing through the projecting flanges of plates secured to the outriggers (Fig. 6.) The outriggers 10 are preferably triangular in form with the bases forming the pivoted ends, and when in an extended position they are secured in place by brace beams 12, removably secured to a plate 15 secured to and bent around the outer end of each outrigger and to a horizontal flange 35 secured to the car body (Fig. 4). On the under side of each outrigger 10 are secured sets of flanges 18 (Fig. 6) to provide for the supporting of the outrigger at any desired distance from the side of the car; preferably by a bolt 19 passed through a set of flanges 18 and the head of a screw jack placed on a suitable support S. Additional guys 13 may be secured to the top of the A frame and to ground anchors to preserve the stability of the frame under excessive lateral strain.

The derrick boom D, formed in two sections preferably of channel beams with lattice bracing, is pivotally secured by a bolt 7 (Fig. 6) running horizontally through flange members secured to the foot of the boom and the top of a swivel pivot member 36 which is seated in the car body between the legs of the A frame. The boom is raised and lowered by means of tackle 9 leading from the top of the A frame to the end of the boom (Fig. 2); the boom is adapted to be swung to either side by tackle 14 running from the end of the boom to the outer ends of the outriggers 10 (Fig. 3). At a point 8 (Fig. 1) adjacent its center the boom is hinged by means of a bolt 26 passing through vertical flanges on the lower sides of the adjoining ends of the boom sections. The boom is thus adapted to fold downward at the hinge in order that the strain of the rigging 9 may constantly act against any tendency of the boom to fold up when extended; in Fig. 7 is shown the upper sides of the adjoining end of the boom sections, wherein there is provided a plate 24 secured to and projecting beyond the end of one of the boom sections and adapted to extend over and be secured to the end of the other section by bolts passing through bolt holes 25; by this means perfect rigidity of the boom when extended is secured. Should it

be desired or necessary to use a short boom, I have provided the lower or foot section of the boom, adjacent the upper end thereof, with a rigging pulley 40 and have provided plate 24 (Fig. 2) with a vertical apertured flange 39. The upper section of the boom having been removed the boom tackle 9 is attached to flange 39, the load hoisting tackle is suspended from the flange through which bolt 26 ordinarily passes, and is run over pulley 40, and the side rigging 14 having been adjusted the lower section is ready for use as a boom.

In Fig. 8 the derrick and attendant parts are represented in their collapsed or lowered positions. In order to collapse the derrick the boom D is lowered to rest on the car or some suitable support, the bolts connecting the upper edges of the boom sections at their point of joinder are removed, the tackle 9 is unfastened from the end of the boom and secured to flange 39 (see also Fig. 1), and by means of the tackle the boom is raised, permitting the upper section thereof to fold down on the lower section, until the folded boom is in an upright position in front of and adjacent to the A-frame. The braces extending from the outriggers 10 to the sides of the car are then removed, the outriggers are swung in to a position parallel with the car, and assume an upright position when the braces are removed from the A-frame and the A-frame and folded boom are lowered until the former rests on I beam 2 and the latter on I beam 1. This folding or collapsing of the derrick structure may be effected without removal or adjustment of the rigging other than the attaching of rigging 9 to flange 39 as above described. The location of the I-beams 1 and 2, the height of the frame, and the lengths of the boom and outriggers are preferably such that when the various parts are in their lowered or collapsed position, the most elevated point of any of the parts will be below or on a line with the roof of the engine house.

Having thus described my invention, what I claim is:

1. The combination with a car of a folding boom carried thereby, comprising a plurality of pivoted sections adapted to be folded together and to be lowered upon the body of the car when folded.
2. The combination with a car of a folding boom and a pivoted derrick frame carried thereby, connections between the frame and the boom, and an outrigger member carried by the frame.
3. The combination with a car of a folding boom and a pivoted derrick frame carried thereby, said boom comprising a plurality of sections adapted to be folded together, and said frame and said boom when folded being adapted to be lowered upon the car body.
4. The combination with a car of a folding boom and a pivoted derrick frame carried

thereby, and an outrigger member carried by the frame, said boom comprising a plurality of sections adapted to be folded together and lowered upon the car body, said frame being adapted to be lowered upon the car body, and said outrigger member being adapted to be swung inward of the car body.

5. The combination with a car of a folding boom and a pivoted derrick frame carried thereby, and a supporting frame mounted on the car body, said boom comprising a plurality of sections adapted to be folded together, and said boom and said derrick frame being adapted to be lowered longitudinally of the car body upon said supporting frame.

6. The combination with a car of a folding boom and a pivoted derrick frame carried thereby, an outrigger member carried by the derrick frame, and a supporting frame mounted on the car body, said boom comprising a plurality of sections adapted to be folded together, said boom and said derrick frame being adapted to be lowered longitudinally of the car body upon said supporting frame, and said outrigger member being adapted to be swung inward of the car body.

7. The combination with a car of a folding boom and a derrick frame carried thereby, an outrigger member carried by said frame, connections between the frame and the boom, connections between the boom and the outrigger member, removable means for securing the frame in an upright position, and remov-

able means for securing the outrigger member in position outward of the car body. 35

8. The combination with a car of a folding boom and a derrick frame carried thereby, an outrigger member carried by said frame, connections between the frame and the boom, connections between the boom and the outrigger member, removable means for securing the frame in an upright position, and removable means for securing the outrigger member in position outward of the car body, said boom and said frame being adapted to be lowered upon the car body. 40 45

9. The combination with a car of a folding boom, and a derrick frame carried thereby, an outrigger member carried by said frame, connections between the frame and the boom, connections between the boom and the outrigger member, removable means for securing the frame in an upright position, and removable means for securing the outrigger member in position outward of the car body, said boom and said frame being adapted to be lowered upon the car body, and said outrigger member being adapted to be swung inward of the car body. 50 55

In testimony whereof I have signed my name to this specification in the presence of two subscribing witnesses. 60

EDWARD F. TERRY.

Witnesses:

R. B. CAVANAGH,

T. E. HARDENBERGH, Jr.