

- [54] **APPARATUS FOR FELLING TREES**
- [75] Inventor: **Per Gustaf Mellgren, Soderhamn, Sweden**
- [73] Assignee: **Kockum Soderhamn Aktiebolag, Soderhamn, Sweden**
- [22] Filed: **Jan. 21, 1971**
- [21] Appl. No.: **108,385**
- [52] U.S. Cl. **144/34 R, 144/309 AC, 144/3 D**
- [51] Int. Cl. **B27b 11/12**
- [58] Field of Search **143/68 F, 68 R, 63, 61, 60, 143/43 N; 144/34 R, 309 AC**

82,789	10/1868	Bauschtliker.....	143/63 R
2,882,941	4/1959	Pope.....	143/43 N
974,971	11/1910	Irwin.....	143/63 R

Primary Examiner—Donald R. Schran
Attorney—Stevens, Davis, Miller & Mosher

[57] **ABSTRACT**

An apparatus for felling trees has an elongated beam carrying a saw-blade, a means for moving the beam back and forth with respect to the tree, and a counter-piece adapted to be moved to compress a tree trunk between it and the saw-blade.

[56] **References Cited**

UNITED STATES PATENTS

1,499,198	6/1924	Swenson	143/68 F
-----------	--------	---------------	----------

11 Claims, 5 Drawing Figures

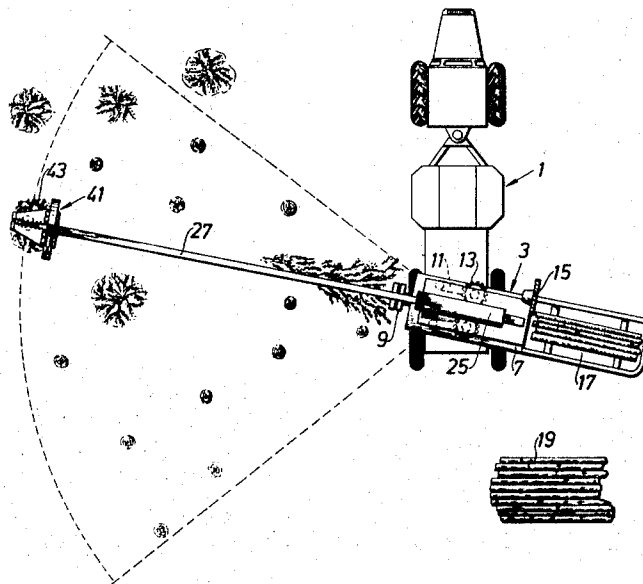

Fig. 1

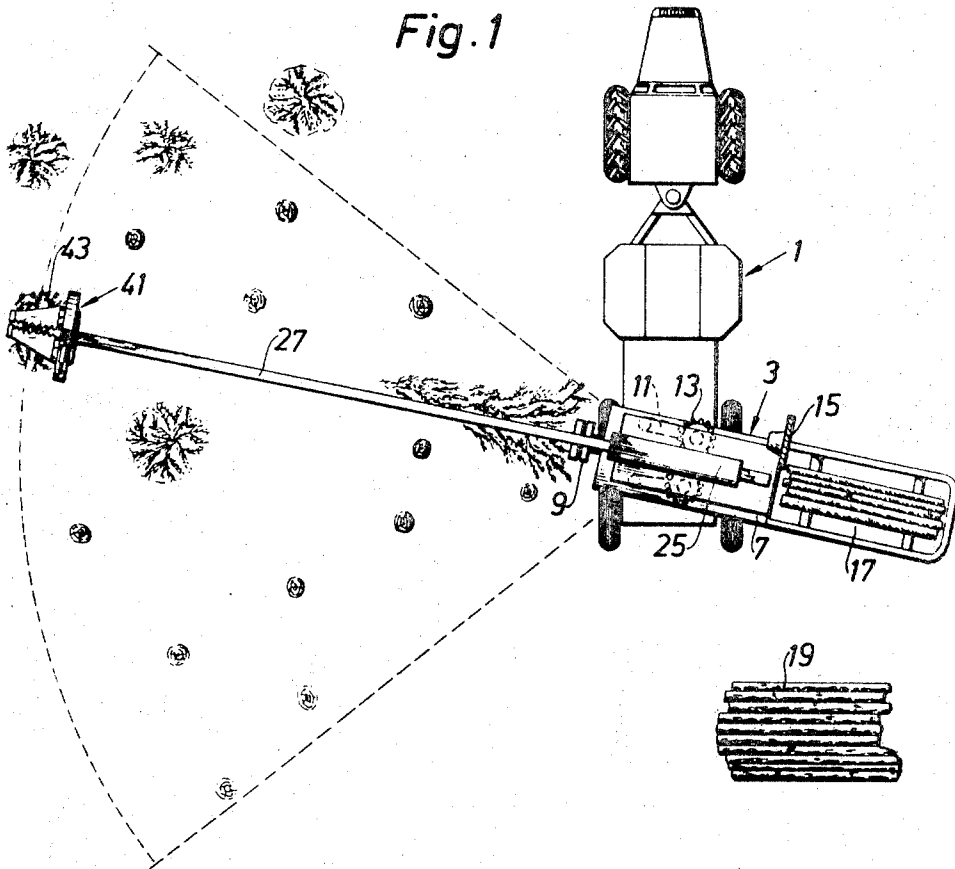
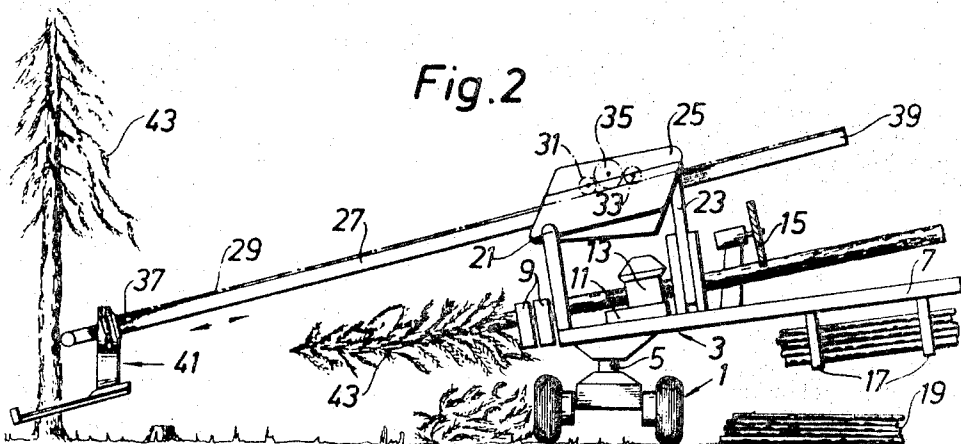

Fig. 2



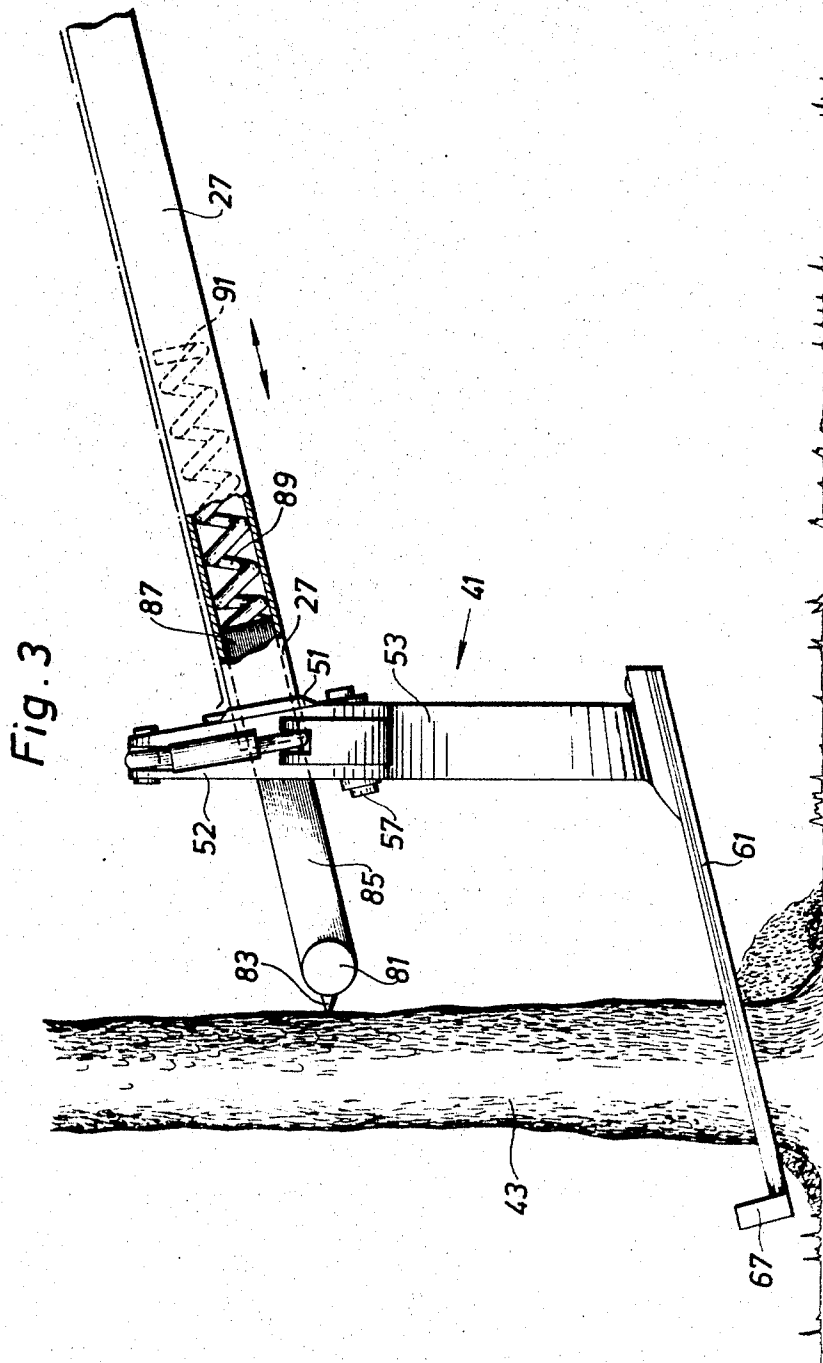

Fig. 4

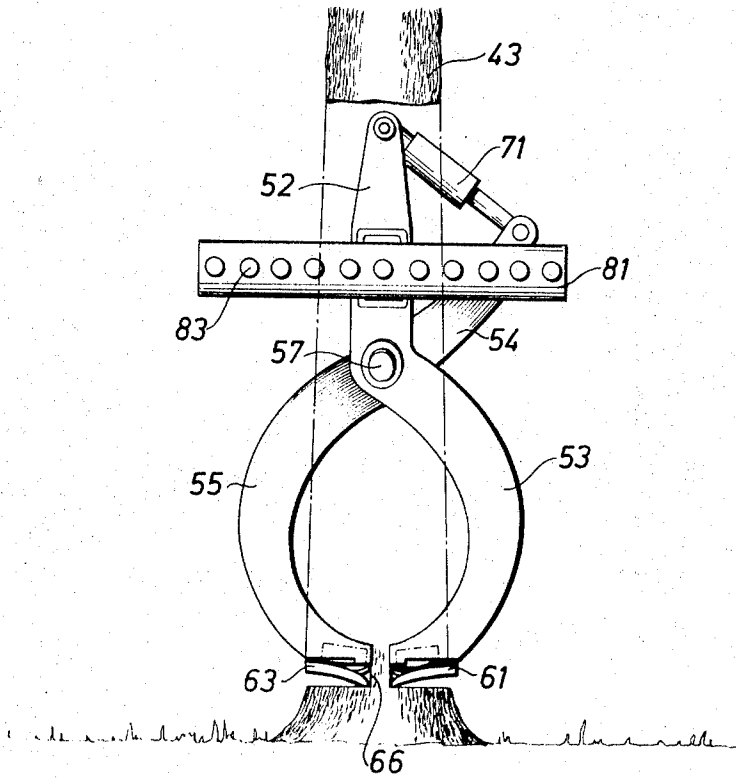
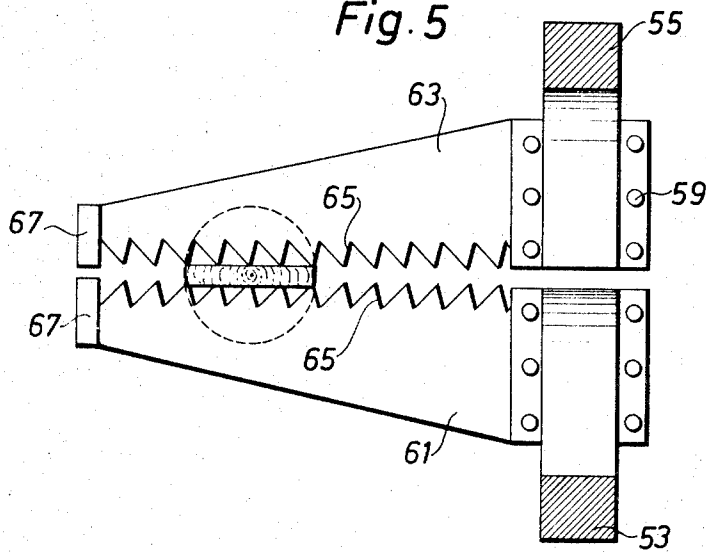

Fig. 5



APPARATUS FOR FELLING TREES

Known apparatus for felling trees can be referred to mainly two construction principles. According to the one principle the felling cut is carried out by a knife which by means of a powerful hydraulic motor is driven through the wood. According to the second principle the felling cut is cut carried out by a chain saw which is likewise usually driven by means of a powerful hydraulic motor, Splitting of the wood is avoided thereby that the tree is held in the original upright position by means of a gripping device or robust arms until the felling cut is finished. In order that a chain saw or sawing sword shall operate satisfactory it is also necessary to prevent the tree from pressing the chain saw during the finishing moment of the cutting operation.

In order to avoid wood damages in the shape of splits which are unacceptable especially in the case of saw timber, the knife for carrying out the felling cut must be thin. On the other hand it is difficult to provide a thin knife which is capable of standing the high stresses to which it is subjected during the cutting operation, and consequently a compromise must be made and, thus, the best result cannot be obtained in most cases.

A chain saw causes normally no wood damages but it is on the other hand more sensitive mechanically and it requires more maintenance costs than a cutting knife and at the same time it requires an expensive and heavy device for holding the tree in the upright position, and unloading the cutting chain from the weight of the tree.

The object of the present invention is to provide a simple apparatus for felling trees which apparatus does not have the above-mentioned drawbacks.

An apparatus according to the invention for felling trees comprises a frame which is preferably carried by a vehicle and an elongated beam or the like which is provided on said frame and is arranged so as to be movable reciprocally in its direction of length by means of a driving device, and the apparatus is characterized in that the beam at at least one of its ends is provided with a saw-blade extending substantially parallel to the beam, means being provided for pressing the saw-blade against the tree to be felled.

Preferably the saw-blade is provided in a fixed relation to the beam in the direction of length of the latter but may, if desired, be movable relatively to the beam in a transverse direction relatively to the direction of length of the beam.

The above-mentioned means for pressing the saw-blade against the tree may consist, for example, of a preferably hydraulic motor connected between the saw-blade or a part coupled thereto and a counter-piece, provided opposite to the saw-blade and adapted to abut against the opposite side of the tree, or a part coupled thereto. Also the counter-piece can consist of a saw blade in which case the cutting of the tree is effected by means of double cutting blades.

In the apparatus according to the invention the cutting of the tree is effected in that the saw-blade and the counter-piece are applied on each side of the tree at the root end thereof whereafter the beam is driven to and fro in its direction of length, the saw-blade thereby cutting into the tree trunk so as so finally cutting off same.

In order to make is possible to cut off the tree by means of only a few strokes of the beam the saw-blade is suitably provided with large teeth and a considerable

setting, e.g., so that the cutting groove with a width of about 10 - 50 mm, depending on the dimension of the tree, is obtained.

The apparatus according to the invention can also comprise a supporting device for preventing the tree from falling to the sides before the cutting operation has been finished. The supporting device is preferably constituted by a member provided with spikes or the like directed towards the tree, said member being provided on the beam and being movable in the direction of length of the beam against the action of a spring force. The support means may be arranged to abut against the tree during the entire cutting operation and, after the cutting has been finished, to act on the tree so that the tree falls in a direction away from the felling apparatus.

The invention will hereinafter be more fully described with reference to the accompanying drawings which, partly schematically illustrate an embodiment of a felling apparatus according to the invention.

On the drawings:

FIGS. 1 and 2 show a vehicle-supported apparatus according to the invention in working position on a logging area, FIG. 1 being a plane view and FIG. 2 being a side view of the apparatus;

FIGS. 3 and 4 show, on an enlarged scale as compared with FIGS. 1 and 2, the cutting arrangement proper and the supporting arrangement in side view and front view respectively, and

FIG. 5 shows the saw-blade of the cutting arrangement as seen from above.

The felling apparatus according to the shown embodiment is supported by a vehicle 1 which, if desired, can be a cross-county vehicle. The apparatus comprises a frame 3 which is turnable on the vehicle about vertical turning axis 5, so that the apparatus can be turned to any desired direction relatively to the direction of length of the vehicle. The frame 3 of the apparatus comprises an elongated supporting member 7 and may also support delimiting members 9 and arms 11 with driven feeding rolls 13 said arms being swingably mounted on the frame and said rolls being provided for feeding a cut tree through the apparatus for delimiting same. Further, the frame 3 may support a log cutter 15 for cutting the tree trunk into suitable lengths the cut logs being collected in a log pocket 17 near the frame from which pocket bundles of logs may be transferred to a log store 19.

The frame of the apparatus further comprises pillars or the like 21 and 23 carrying a housing through which a crane beam 27 extends. The beam 27 is carried in the housing 25 in a manner not shown by means of supporting rolls or supporting rails so that it is movable in its direction of length to and fro, suitably from the one end 37 to the other end 39 thereof. The driving of the beam 27 to and fro in its direction of length is suitably effected by means of a chain 29, the ends thereof being fixed to the ends 37 and 39, respectively, of the beam, the chain being lead in the housing 25 over chain wheels 31 and 33, serving as deflector rolls, and over a chain wheel 35 between the chain wheels 31 and 33, the wheel 35 being arranged to be rotated alternating in the one or the other direction by means of a motor, not shown, which is suitably a hydraulic motor.

At the one end 37 of the beam 27 a cutting unit 41 for cutting trees 43 is provided. The cutting unit consists of two arms 53 and 55 which are swingably connected to each other by means of an axis 57 situated immediately beneath the beam 27 and extending substantially parallel to the beam. At the lower ends thereof each of the arms 53 and 55 is connected to a saw-blade 61 and 63 respectively at one end thereof by means of rivets 59. At the opposite ends thereof the saw-blades are provided with stop means 67 which are intended to prevent the saw-blades from being drawn out from the saw-cut during the sawing operation. The saw-blades are robust in that the thickness thereof may be, for example, 8 to 40 mm, suitably 10 to 30 mm, at the thickest portion thereof. The saw blades are further suitably shaped in a wedge-like manner so as to show a decreasing thickness in a direction towards the back thereof in order to decrease the risk for clamping and to provide sufficient space for the saw dust to be fed out. The saw teeth 65 are made particularly robust and large for obtaining a large working capacity per saw tooth. Further, the saw teeth suitably have a considerable setting which is indicated at 66 in FIG. 4. By means of such dimensioning and setting of the saw-blades the saw-cut will become sufficiently wide suitably of the order 10 to 50 mm, thereby avoiding the risk that the saw-blades are clamped during the cutting operation.

The arm 53 has an upwardly directed extension 52 and in similar manner the arm 55 has an upwardly directed extension 54. Between the free ends of the extensions 52 and 54 is inserted a hydraulic motor 71 by means of which the saw-blades can be pressed against the tree trunk 43 with a large force during the cutting operation.

The extension 52 is fixed to the beam 27 by means of a fixing plate 51.

The apparatus according to the invention further comprises a supporting device for preventing the tree from falling to the one or the other sides during the finishing stage of the felling operation. The supporting device comprises a robust tube or the like 81 extending perpendicularly to the beam 27 and being fixed to a pin 85 provided with a portion 87 extending into the tube-shaped beam 27 and actuated by one end of a strong compression spring in the shape of a helical spring provided in the beam 27, the other end of said spring abutting against a fixed support 91 in the beam. A stop, not shown, prevents the pin 85 from being entirely pushed out from the beam. At the side thereof facing the tree the tube 81 is provided with a number of spikes 83 which are intended to penetrate into the tree trunk under the action of the pressure from the helical spring 89.

The apparatus now described is used and operates in the following manner.

After the apparatus having been moved to the intended logging site the beam 27 is directed successively towards the trees to be harvested. For such harvesting operation the saw-blades 61 and 63 are first separated as much as possible from each other by means of the hydraulic motor 71 whereafter the beam 27 is moved towards the tree so that the saw-blades encompass the tree. In this operation the supporting device will also engage the tree with its pins 83. Thereafter the hydraulic motor 71 is actuated so that the saw-blades engage

the tree trunk with a high force. After this has been done the beam 27 is driven to and fro by means of driving means in the housing 25 the length of the strokes being limited by the length of the saw-blades. During the sawing movement the supporting device engages the tree trunk all the time and keeps the tree in an upright position. Thanks to the large saw-teeth and the high pressure between the saw-blades and the tree trunk only few sawing strokes are required for cutting off the tree. As an example, in cutting tree trunks with a diameter of about 20 to 30 cm the number of sawing cycles or complete strokes to and fro for cutting of the tree can be three to four. As the tree has been cut off the pressure effected by the supporting device on the tree trunk results in that the tree falls in a direction away from the felling apparatus. When the tree has fallen to the ground it is gripped by means of the saw-blades 61 and/or the arms 53 and 55 whereafter the beam 27 is drawn backwards for feeding the tree into the delimiting and cutting device arranged beneath the housing 25. This movement of the beam is continued until the tree trunk can be gripped by the feeding rolls 13. While the tree is being delimiting the apparatus is turned towards the next tree to be harvested. It is evident that by means of the shown apparatus it is possible to choose as desired the trees to be harvested and to leave such trees which shall remain, so that the apparatus is particularly well suited for thinning purposes.

Since the work for cutting the trees is effected by the beam of the apparatus according to the invention and the driving means therefor, and since the cutting device proper only requires a single hydraulic motor of simple construction, i.e., the motor 71, the cutting unit can be a very light and simple construction. Also the hydraulic conduit, not shown, extending along the beam 2 and provided for feeding the hydraulic motor 71 can be simple and does not pose any construction problems which would be the case if the cutting unit had been made in a conventional manner with a separate motor for effecting the cutting work. Also it should be remembered that, as pointed out before, the cutting unit of the apparatus according to the invention can be directly used also as a gripping device for cut trees.

An essential advantage of the apparatus according to the invention is also that the saw-blades can be engaged against the tree trunk to be harvested at a distance from the ground which is considerably shorter than what is normally possible with cutting devices hitherto known. Thus, the wood losses can be kept to a minimum.

The invention is not limited to the embodiment shown and described since said embodiment may be modified and changed in various manners within the scope of the invention. Thus, it may be pointed out that, although the cutting operation is preferably carried out by means of two saw-blades, the one or the other hereof may be substituted by a counterpiece without sawteeth. Further, the saw-blades and the counter-piece, if any, can be supported in a different manner than by means of arms connected to each other as in the shown embodiment. Also the supporting device for the tree may be constructed in a manner differing from that shown.

What I claim is:

1. An apparatus for felling tress comprising

- a. a frame carried by a vehicle movable over a logging area;
- b. a sturdy, elongated beam supported on the frame and movable relative to said vehicle in a direction towards and from a tree to be felled;
- c. means for moving the beam;
- d. a sturdy saw-blade carried by said beam at one end thereof;
- e. a counter-piece carried by the beam disposed in opposed relationship with the saw-blade;
- f. means for moving said saw-blade and said counter-piece towards each other whereby a tree may be pressed therebetween; said saw-blade carrying large teeth and being capable of cutting through a tree trunk by a few back and forth movements of the beam and saw-blade.

2. The apparatus of claim 1, in which said counter-piece is a saw-blade.

3. The apparatus of claim 1, in which said driving means comprises a hydraulic motor connected between the saw-blade and the counter-piece.

4. The apparatus of claim 1, in which said saw-blade is swingably mounted relative to said beam about a substantially vertical axis.

5. The apparatus of claim 1, in which said counter-piece is swingably mounted relative to said beam about a substantially vertical axis.

6. The apparatus of claim 1, in which the saw-blade or the counter-piece is provided on a carrier turnably mounted to the beam about an axis substantially parallel to the direction of length of the saw blade.

7. The apparatus of claim 1, comprising a supporting device for preventing the tree from falling sidewise be-

fore the tree has been cut off.

8. The apparatus of claim 7, in which the supporting device consists of a member provided with spikes or the like directed towards the tree, said member being mounted to the beam and being movable substantially in the direction of length of the beam against the action of a spring force.

9. The apparatus of claim 1, in which the frame of the apparatus is turnably mounted on a cross-country vehicle about a vertical axis so that the beam can be set in any desired direction relatively to the direction of length of the vehicle.

10. The apparatus of claim 1, in which the saw-blade is carried from the beam at its one end and is provided at its other end with a stop member for preventing the saw-blade from being entirely drawn out from the saw groove.

11. An apparatus for felling tress comprising a vehicle, an elongated horizontal beam pivotally supported adjacent one end thereof to move about a vertical axis, means for moving the beam longitudinally back and forth, means carried by the beam at the other end thereof comprising a pair of arms having arcuate shaped portions each carrying a saw blade at one end thereof with its longitudinal axis lying in a plane substantially parallel to the longitudinal axis of the beam, said arms being pivotally secured together at a diagonally spaced point from the saw blades, and means for pivoting the arms to and from each other, said saw blades being wedge-shaped across the width thereof with the thickest edge being the cutting teeth thereof.

* * * * *

35

40

45

50

55

60

65