



INTERNATIONAL APPLICATION PUBLISHED UNDER THE PATENT COOPERATION TREATY (PCT)

| | | |
|--|------------------|---|
| <p>(51) International Patent Classification³ : F01B 31/08; F01P 3/10</p> | <p>A1</p> | <p>(11) International Publication Number: WO 83/ 02300 (43) International Publication Date: 7 July 1983 (07.07.83)</p> |
| <p>(21) International Application Number: PCT/US82/01760 (22) International Filing Date: 17 December 1982 (17.12.82) (31) Priority Application Number: 335,266 (32) Priority Date: 28 December 1981 (28.12.81) (33) Priority Country: US (71) Applicant: ALCO POWER INC. [US/US]; 100 Orchard Street, Auburn, NY 13021 (US). (72) Inventor: MILLS, Floyd, D. ; P.O. Box 233, Route 90, King Ferry, NY 13081 (US). (74) Agent: KILE, Bradford, E.; 815 Connecticut Avenue, N.W., Washington, D.C. 20006 (US). (81) Designated States: DE, JP.</p> | | <p>Published <i>With international search report.</i></p> |

(54) Title: PRESTRESSED COMPOSITE PISTON

(57) Abstract
A prestressed composite piston (34) for an internal combustion engine including a generally cylindrical piston body (70) formed from an aluminum alloy and a piston crown (50) formed from a cast metallic material. The crown (50) is mated to the piston body (70) by a single machine bolt (90) which prestresses the crown in a generally uniform concentric pattern.

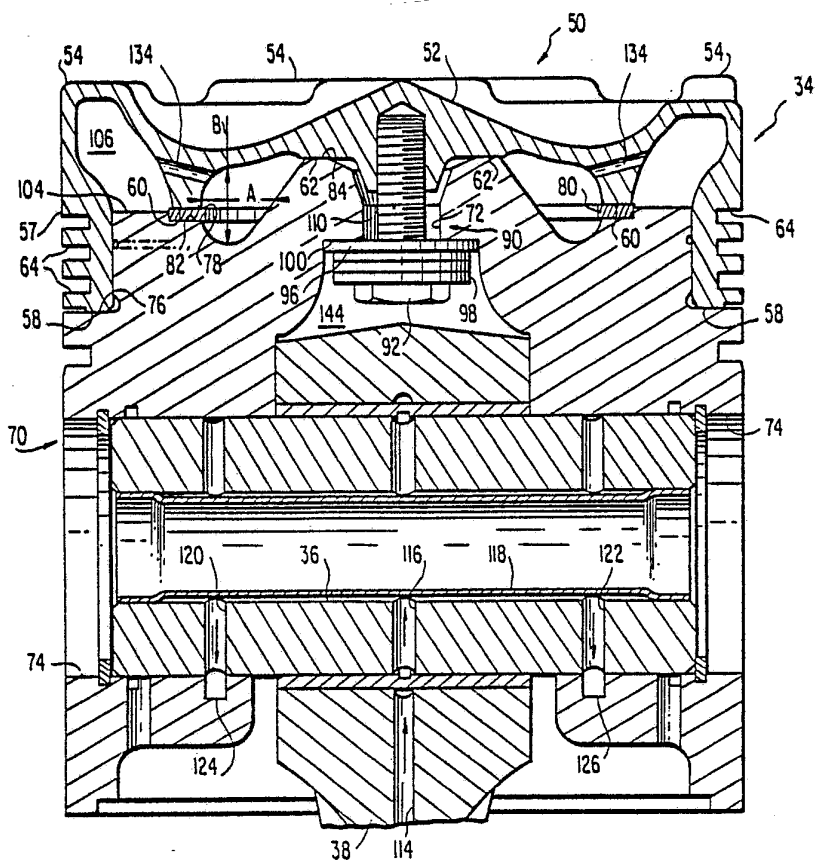

FOR THE PURPOSES OF INFORMATION ONLY

Codes used to identify States party to the PCT on the front pages of pamphlets publishing international applications under the PCT.

| | | | |
|----|---------------------------------------|----|--------------------------|
| AT | Austria | LI | Liechtenstein |
| AU | Australia | LK | Sri Lanka |
| BE | Belgium | LU | Luxembourg |
| BR | Brazil | MC | Monaco |
| CF | Central African Republic | MG | Madagascar |
| CG | Congo | MR | Mauritania |
| CH | Switzerland | MW | Malawi |
| CM | Cameroon | NL | Netherlands |
| DE | Germany, Federal Republic of | NO | Norway |
| DK | Denmark | RO | Romania |
| FI | Finland | SE | Sweden |
| FR | France | SN | Senegal |
| GA | Gabon | SU | Soviet Union |
| GB | United Kingdom | TD | Chad |
| HU | Hungary | TG | Togo |
| JP | Japan | US | United States of America |
| KP | Democratic People's Republic of Korea | | |

- 1 -

DESCRIPTION
PRESTRESSED COMPOSITE PISTON

This invention relates to a prestressed composite piston. More specifically this invention relates to
5 and is an improvement on the invention of a United States Tromel patent No. 3,465,651, of common assignment with the subject application.

Deisel engines have, for many years, been the standard working engine of industry. Diesel engines
10 key the drive train for deisel electric locomotives, ships of various classes, such as tug boats, and various other working vehicles, including tractors, tanks, and the like. In addition, diesel engines have found application in stationary environments to drive
15 large compressors and electric generators. Such stationary engines may include designs having eighteen or more cylinders with engine block bores of approximately a foot or so in diameter.

Since the inception of the diesel engine,
20 researchers have labored, with varying degrees of success, to improve the power and efficiency of diesel engines. In this connection, one notable advance was the development of a composite piston. More specifically, multi-part pistons were constructed of
25 various materials designed to benefit performance. As an example, an aluminum alloy piston body was mated with a ferrous alloy cap. Aluminum was selected because it is light in weight and exhibits excellent bearing properties. This permits the piston skirt to
30 translate smoothly within a cylinder liner and facilitate the oscillating action of a wrist pin extending through the piston body. Aluminum alloys, however, tend to have a relatively high coefficient of expansion and low strength at high temperatures.
35 Accordingly, an all-aluminum alloy piston must be isolated from the high temperatures that exist within the cylinders of internal combustion engines.



-2-

A ferrous alloy cap generally made of steel or cast iron was selected because such caps retain high strength at cylinder operating temperatures. Moreover ferrous alloys can receive piston rings without exhibiting excessive "pounding out" or wear.

One significant difficulty encountered with composite pistons was the creation of thermal stresses within the piston. This problem was alleviated to a degree by the incorporation of chambers or galleries within the piston body and cap interface. These galleries were supplied with oil circulated from the engine block which tended to cool the high operating temperature of the piston cap. Notwithstanding such cooling action, significant thermal stresses continued to exist.

A significant advance in the composite piston art was realized with the disclosure of the invention embodied in the above identified United States Tromel patent No. 3,465,651, the disclosure of which is hereby incorporated by reference as though set forth at length. Briefly, however, the Tromel patent discloses a composite piston with a central stud integral with the crown. The crown is formed from a ferrous alloy having high tensile strength and the stud is threaded to receive a nut which is used to draw the crown into progressive engagement with the piston body. Accordingly the crown is prestressed to offset operating thermal stresses.

Notwithstanding the substantial and successful application of the Tromel invention, it would be desirable to provide a uniformly prestressed composite piston exhibiting an improved operating balance to facilitate smooth operation of the internal combustion engine. Further, it would be desirable to provide a composite piston having reduced material costs. Still further, it would be desirable to facilitate manufacture of the piston crown including a contoured upper surface to optimize combustion zone configuration. In addition it would be highly desirable to



-3-

provide a composite piston with enhanced cooling characteristics. It would also be desirable to provide a composite piston wherein the crown could be configured to accommodate valve pockets for turbo-diesel engines while retaining a substantially uniform wall thickness to minimize thermal stresses in the crown.

Others have attempted to improve upon the prestressed composite piston invention of Tromel. Such designs, however, involve a plurality of bolts or fasteners which create stresses at each bolt location. Accordingly, any prestressing achieved is not uniform across the crown. Moreover in many instances prior designs employ a plurality of fasteners which pierce the piston crown and thus detract from the seal integrity of the composite piston assembly. Still further multiple fastener designs tend to be somewhat difficult to manufacture and assemble.

The difficulties and/or disadvantages suggested in the preceding are not intended to be exhaustive, but rather are among many such deficiencies known to those skilled in the art which have tended to reduce the effectiveness and desirability of prior composite piston assemblies. Other noteworthy problems may also exist; however, those presented above should be sufficient to demonstrate that prestressed composite piston assemblies appearing in the past will admit to worthwhile improvement.

OBJECTS OF THE INVENTION

It is therefore a general object of the invention to provide a novel, prestressed, composite piston which will obviate or minimize difficulties of the type previously described.

It is a specific object of the invention to provide a prestressed composite piston which will facilitate the balance of a multiple piston internal combustion engine.



-4-

It is another object of the invention to provide a prestressed composite piston which will exhibit enhanced cooling characteristics.

It is yet another object of the invention to provide a
5 prestressed composite piston which will have a substantially concentric prestress pattern across the piston crown.

It is still another object of the invention to provide a prestressed composite piston which will reduce the cost of materials utilized and concomitantly facilitate produc-
10 tion and assembly.

It is a further object of the invention to provide a prestressed composite piston which may be facilely fashioned with an irregular upper crown configuration to permit combustion chamber shape optimization while mini-
15 mizing thermal stresses in the piston crown.

It is yet a further object of the invention to provide a prestressed composite piston wherein prestressing may be achieved without piercing the piston crown.

20 BRIEF SUMMARY OF A PREFERRED EMBODIMENT
OF THE INVENTION

A preferred embodiment of the invention which is intended to accomplish at least some of the foregoing objects entails a composite piston having a generally cylindrical piston body formed from a relatively light
25 weight material and a protective crown formed from a cast metallic material.

The piston body is fashioned with a central longitudinal aperture, a first seat peripherally fashioned about the outer circumference of the piston body, a second seat
30 generally axially directed and concentrically fashioned upon the piston body radially inwardly with respect to the first seat and a third seat generally axially directed and concentrically fashioned upon the piston body radially



inward with respect to the second seat and radially outward with respect to the central longitudinal aperture.

The piston crown includes an outer peripheral skirt having a first rim portion dimensioned to interferringly engage with the first seat of said piston body, a second rim portion, generally axially extending and positioned radially inward with respect to the first rim on a lower surface of the crown and being dimensioned to cooperate with the second seat of the piston body, and a third rim portion concentrically positioned radially inward on the lower surface of the crown and being dimensioned to cooperate with the third seat of the piston body.

A threaded fastener extends through the central aperture of the piston body and has a head portion operable to bear against a peripheral seat fashioned around the central aperture and a threaded portion operable to extend through the central aperture and engage a compatibly threaded bore coaxially formed within the lower surface of the crown.

The first, second and third rim portions of the crown are axially dimensioned in a relaxed condition such that upon full seating of the first rim with the first seat an axial gap will extend between the second rim and the second seat and a greater axial gap will extend between the third rim and the third seat. The threaded fastener is operable to sequentially draw the second rim into abutting engagement with the second seat and the third rim into abutting engagement with the third seat from a single central location to uniformly prestress the crown against the piston body and produce a compact composite piston assembly operable to enhance the balance of the piston in operation without piercing the upper surface of the crown.

The upper surface of the crown is provided with a peripheral zone with elevated segments and recessed segments to accommodate valve action of an internal combustion engine and the corresponding lower surface of the crown beneath the peripheral zone generally follows the contour of the



-6-

upper surface such that the crown thickness is substantially uniform throughout the peripheral zone to minimize thermal stresses within the crown throughout the peripheral zone.

5

THE DRAWINGS

Other objects and advantages of the present invention will become apparent from the following detailed description of a preferred embodiment thereof taken in conjunction with the accompanying drawings, wherein:

10 FIGURE 1 is an axonometric view of a stationary diesel-generator set of the type suitable to advantageously utilize the prestressed composite piston of the subject invention;

15 FIGURE 2 is a partial cross-sectional and broken away view of the diesel engine depicted in FIGURE 1 wherein a prestressed composite piston is disclosed within a cylinder sleeve of the V-18 diesel engine;

20 FIGURE 3 is a top view of a prestressed composite piston in accordance with a preferred embodiment of the invention wherein the upper surface of the piston crown is contoured to accommodate valve action in a turbo-charged engine;

25 FIGURE 4 is a detail cross-sectional view of the prestressed composite piston depicted in FIGURE 3 wherein the piston body is viewed along section line 4-4 and the piston crown is viewed along section line 4-4a to disclose the generally uniform thickness of the piston crown around an outer peripheral zone having valve pockets;



-7-

FIGURE 5 is a plan view of the piston body and discloses, in phantom, oil channels within the piston body to provide cooling for the piston crown;

FIGURE 6 is a partial cross-sectional view taken along section line 6-6 in FIGURE 5;

FIGURE 7 is a partial cross-sectional view taken along section line 7-7 in FIGURE 5;

FIGURE 8 is a partial cross-sectional view taken along section line 8-8 in FIGURE 5;

10 FIGURE 9 is a cross-sectional view taken along section line 9-9 in FIGURE 5;

FIGURE 10, note sheet 3, is an exploded cross-sectional view of a composite piston in accordance with the invention prior to assembly;

15 FIGURE 11 is a cross-sectional view of the composite piston depicted in FIGURE 10 wherein a first rim portion of the piston crown is interferringly engaged with a first seat fashioned about the outer circumference of the piston body;

20 FIGURE 12, note sheet 2, is a partial, cross-sectional view taken along section line 12-12 in FIGURE 5;

FIGURE 13 is a partial cross-sectional view taken along section line 13-13 in FIGURE 5;

25 FIGURE 14, note sheet 5, is a cross-sectional view of the composite piston depicted in FIGURE 10 wherein a second rim portion of the piston crown is drawn by a central threaded fastener into engagement with a second seat to



-8-

partially prestress the piston crown in a uniform circumferential pattern; and

FIGURE 15 is a cross-sectional view of the composite piston depicted in FIGURE 14 wherein the central threaded fastener has drawn a third rim portion of the crown into engagement with a third seat of the piston body to provide a compact piston composite wherein the crown is symmetrically prestressed from a single central location without piercing the crown.

10

DETAILED DESCRIPTION

Context of the Invention

Before presenting a detailed description of the subject prestressed composite piston, it may be worthwhile to briefly outline the operating context of the instant invention.

Referring to FIGURES 1 and 2, and as noted above, one area where prestressed composite pistons have been utilized is in stationary diesel engines of diesel-electric generator type. FIGURE 1 discloses an electrical generator having an armature directly coupled to the drive shaft of a tandem mounted eighteen cylinder diesel engine. The engine is turbo charged by a compressor which delivers high pressure air through a central manifold to individual working chambers via conduits 28.

The piston cylinders are arranged in V-pairs within an engine block 30 and cylinder liners 32 slidably receive a composite piston 34 as shown specifically in FIGURE 2. The composite piston 34 is connected to a drive shaft by a wrist pin 36 and connecting arm 38. Four valves 40 are positioned above each cylinder and remain open during turbocharging as the piston passes through top-dead-center. In order to optimize the configuration of the combustion chamber it is necessary to fashion an upper portion of the piston with cut-out zones to accommodate the open valves as the piston passes through the top-dead-center position.



-9-

Moreover it has been determined that the balance of the engine can be enhanced if the mass of the piston above the wrist pin 36 is minimized.

Prestressed Composite Piston

5 Turning now to FIGURES 3 and 4 there will be seen detailed views of a prestressed composite piston in accordance with the invention. As noted in FIGURE 3 the piston 34 includes a cap or crown 50. An upper surface 52 of the crown is fashioned with a central conical shape, note
10 FIGURE 4, to provide enhanced fuel burning characteristics and optimization of the combustion chamber shape. In addition the upper surface of the crown is fashioned with a plurality of elevated segments 54 in a peripheral zone about the crown. Recessed segments 56 are formed between
15 the elevated segments 54 and have an inwardly arcuate configuration to accommodate an outer peripheral edge of valves 40 at top-dead-center of the super charging cycle of the engine as discussed above.

 Significantly the crown thickness is maintained ap-
20 proximately uniform throughout this peripheral zone to minimize thermal stressing of the crown. This uniform thickness can be achieved without expensive machining by utilizing a casting process. Ferrous metals, which can be cast, can be advantageously utilized with the present
25 invention, as opposed to previously known high tensile strength alloys which were more expensive machining and required subsequent hand blending to form valve pockets.

 The piston crown further includes a contoured lower surface having an outer peripheral skirt 57 with a first
30 rim portion 58, a second rim portion 60 and a third rim portion 62. Each of the rims are concentric and bear against corresponding seat members of a piston body portion which will be discussed more fully below. The peripheral skirt is formed with a plurality of parallel peripheral
35 channels 64 to hold conventional piston rings. The high strength character of the ferrous alloy of the cap prevents



-10-

excessive "pounding out" or wear of the piston by the rings.

A second portion of the composite piston 34 comprises a generally cylindrical piston body 70. The piston body 70 is preferably composed of a light weight material such as an aluminum alloy having good bearing characteristics. A central longitudinal aperture 72 extends axially through the piston body for receiving a mounting member and a transverse bore 74 extends at a right angle to the axis of aperture 72. As previously indicated a connecting arm 38 is connected to the piston body by a transverse wrist pin 36 extending within bore 74.

The piston body is formed with a first seat 76 peripherally fashioned about the outer circumference of the piston body. A second seat 78 is formed by a bearing ring 80 set within a recess 82. The second seat is generally axially directed and concentrically positioned upon the piston body radially inward with respect to the first seat 76. The piston body is further formed with a third seat 84 which is generally axially directed and concentrically positioned radially inward with respect to the second seat 78 and radially outward with respect to the central longitudinal aperture 72 through the piston body.

As previously mentioned a threaded fastener or machine bolt 90 operably extends through the aperture 72 in the piston body. The machine bolt has a head portion 92 and a threaded shank 94. A bearing washer 96 and a plurality of spring washers 98 are operably carried by the machine bolt and bear against an abutment 100 formed by an undercut surface of the piston body. A threaded bore 102 is coaxially formed within a lower surface of the crown 50. In operation the single machine bolt 90 draws the crown into prestressed mating engagement with the piston body as will be discussed hereinafter.



-11-

In order to cool the piston crown 50 oil is circulated beneath the crown in chambers or galleys. In this connection, an inner surface of the crown between the first rim 58 and the second rim 60 and an axial surface 104 of the piston body forms a first peripheral cooling galley 106
5 beneath the crown.

In a similar manner a second cooling galley 108 is concentrically formed inwardly with respect to the first peripheral cooling galley 106 between the second rim 60 and
10 the third rim 62 of the piston crown. This second peripheral cooling galley includes a recessed portion 108 formed within the piston body such that the second cooling galley has a width "A" to height "B" ratio of approximately one. This aspect ratio of the second galley advantageously enhances
15 the "cocktail shaking" effect of the cooling oil and thus cooling of the piston crown.

Finally a third cooling galley 110 is formed beneath the piston crown between the interior surface of the central longitudinal aperture 72 of the piston body and the exterior
20 surface of the machine bolt shank 94.

Referring now to FIGURES 4-7 there will be seen a system for delivering cooling oil from the engine crank case into the piston cooling chambers. More specifically cooling oil is pumped up to the piston body 70 through a
25 bore 114, note FIGURE 4, in the connecting rod 38. Oil then travels through a bore 116 in the wrist pin 36 and axially in both directions therefrom within a cylindrical void formed by a coaxial sleeve 118. The oil then passes outwardly through bores 120 and 122 into channels 124 and
30 126 respectively. As seen in FIGURE 6, channel 124 communicates with bore 128 which opens into the first cooling galley 106 at outlet 130, note FIGURE 5. In a similar manner, oil from channel 126 exits into the first galley via outlet 132.

35 From the first galley 106, oil passes through a plurality of bores 134 extending through the piston crown 50, note again FIGURE 4. Although two such bores are shown,



-12-

additional passages may be provided to enhance the flow of oil into the second cooling galley. A plurality of bores 140 extend through the piston body and provide communication between the second and third cooling galleys
5 to complete the supply side of the cooling system.

As the oil is pumped from galley to galley the piston reciprocates rapidly up and down to create a cocktail shaking action within the cooling galleys. The continual circulation of oil and the cocktail shaking action in
10 the three toroidal like galleys beneath the piston crown advantageously serve to keep the piston crown relatively cool and thereby reduce thermal stressing within the crown.

Return of the cooling oil to sump is provided by a plurality of bores 142 which communicate between the second
15 galley 108 and a recess 144 in the piston body above the connecting arm, note FIGURE 8. In a similar manner, the third galley is drained by bores 146 which empty into recess 144, note FIGURE 9.

Method of Assembly

20 Turning now to FIGURES 10-15 a sequence of assembly of the piston is shown. In FIGURE 10 the crown 50 is shown positioned above the piston body 70. A hardened bearing ring 80 is first mounted within recess 82 to form a seat. The crown 50 is then mounted upon the body 70 as shown in
25 FIGURE 11.

The inside dimension of the crown skirt 57 is slightly less than the outside dimension of the piston body to create an interference fit. In order to facilitate assembly, oil under 6,000 psig is delivered through a bore 150 in the
30 piston body 70, note FIGURE 12, to the skirt 57. This tends to expand the skirt portion of the crown. Simultaneously 2,000 lbs. of force is applied to the crown, as shown by arrows C in FIGURE 11 to force the crown onto the piston body until the first rim portion 58 of the crown
35 firmly engages the first seat 76 of the piston body. As



-13-

shown in FIGURES 5 and 13 drain bore 152 serves to provide a return of oil during this assembly step.

The axial dimensions of the first 58, second 60 and third 62 rim portions of the crown, in a relaxed condition, are such that upon full seating of the first rim 58 with the first seat 76 an axial gap extends between the second rim 60 and the second seat 78 and a greater axial gap extends between the third rim portion 62 and the third seat 84, note FIGURE 11.

In FIGURE 14 the machine bolt 90 is shown engaging the piston crown 50 and drawing the same toward the piston body 70. As the machine bolt 90 is tightened the second rim portion 60 of the piston crown is drawn into engagement with the second peripheral seat 78. Accordingly the piston crown between the first and second rim portions is placed in a symmetrical prestressed condition. In this posture it will be seen, however, that the third rim 62 is still spaced from the third seat 84, note FIGURE 14.

In FIGURE 15, the piston crown 50 and piston body 70 are shown in a fully assembled condition. More particularly the machine bolt 90 has been fully tightened and the spring washers 98 are partially flattened. The third rim portion 62 of the crown has been drawing into abutting engagement with the third seat 84. In this assembled posture the piston crown 50 is fully prestressed in a generally uniform concentric manner from a single central location without piercing the upper surface of the crown.

SUMMARY OF MAJOR ADVANTAGES OF THE INVENTION

After reading and understanding the foregoing description of the invention, in conjunction with the drawings, it will be appreciated that several advantages of the subject prestressed composite piston are obtained.



-14-

Without attempting to set forth all of the desirable features of the instant composite piston at least some of the major advantages include the provision of an axially compact piston having a reduced height and mass above
5 the wrist pin. This reduction of mass at the end of the connecting rod enhances the balance of the internal combustion engine.

The subject invention also provides an enlarged first cooling galley, a second cooling galley with an aspect
10 ratio of approximately one and a third cooling galley. The aspect ratio of the second galley enhances the cocktail shaking and cooling effect of the circulating oil.

The single machine bolt is operable to sequentially prestress the crown from a central location in a concentric
15 manner. Moreover the substantially uniform pretension is effected without piercing the upper surface of the crown.

With the instant invention it is possible to cast the crown out of ferrous alloys which are considerably less expensive than previously required alloys having high ten-
20 sion strength. Synergistically the casting process can be advantageously utilized to form valve wells in the upper peripheral surface of the crown. Thus expensive machining of the valve pocket surface is eliminated as well as laborious hand radiusing. Still further the casting process is
25 effective to create a contour beneath the crown which will follow the upper valve pocket surface. This generally uniform thickness of the outer peripheral rim of the crown minimizes thermal stressing of the crown in operation.

In describing the invention, reference has been made
30 to a preferred embodiment and illustrative advantages of the invention. Those skilled in the art, however, and after reading the instant disclosure of the subject invention, may recognize additions, deletions, modifications, substitutions and/or other changes which will fall within
35 the purview of the subject invention and claims.



-15-

Claims

1. A composite piston for an internal combustion engine comprising:

5 a generally cylindrical piston body formed from a relatively light weight material, said piston body having,

a central longitudinal aperture;

a first seat peripherally fashioned about the outer circumference of said piston body,

10 a second seat generally axially directed and concentrically fashioned upon said piston body radially inwardly with respect to said first seat,

15 a third seat generally axially directed and concentrically fashioned upon said piston body radially inward with respect to said second seat and radially outward with respect to said central longitudinal aperture; and

20 a crown formed from a cast metallic material said crown having an upper and lower contoured surfaces and including,

an outer peripheral skirt including a first rim portion dimensioned to interferringly engage with said first seat of said piston body,

25 a second rim portion, generally axially extending and positioned radially inward with respect to



-16-

said first rim on a lower surface of said crown and being dimensioned to cooperate with said second seat of said piston body, and

5 a third rim portion concentrically positioned radially inward on the lower surface of said crown and being dimensioned to cooperate with said third seat of said piston body;

10 threaded fastener means extending through said central aperture of said piston body and having a head portion operable to bear against a peripheral seat fashioned around said central aperture and a threaded portion operable to extend through said central aperture and engage a compatibly threaded bore coaxially formed within the lower surface of said crown;

15 said first, second and third rim portions of said crown being axially dimensioned in a relaxed condition such that upon full seating of said first rim with said first seat an axial gap extends between said second rim and said second seat and a greater axial gap extends between said third rim and said third seat, and said threaded fastener means being operable to sequentially draw said second rim into abutting engagement with said second seat and said third rim into abutting engagement with said third seat from a single central location to concentrically prestress said crown against said piston body and produce a compact composite piston assembly operable to enhance the balance of the piston in operation without piercing the upper surface of said crown; and

30 said upper surface of said crown having a peripheral zone with elevated segments and recessed segments to accommodate valve action of an internal combustion



-17-

5 engine and said corresponding lower surface of said crown beneath said peripheral zone generally following the contour of said upper surface such that the crown thickness is substantially uniform throughout said peripheral zone to minimize thermal stresses within said crown throughout said peripheral zone.

2. A composite piston for an internal combustion engine as defined in claim 1 wherein:

10 the inner surface of said crown between said first rim and said second rim and an axial surface of said piston body between said first seat and second seat forms a first peripheral cooling galley beneath said crown.

3. A composite piston for an internal combustion engine as defined in claim 2 wherein:

15 the inner surface of said crown between said second rim and said third rim and an axial surface of said piston body between said second seat and said third seat forms a second peripheral cooling galley concentrically disposed inwardly with respect to said first peripheral cooling galley beneath said crown.

20

4. A composite piston for an internal combustion engine as defined in claim 3 and further comprising:

25 first bore means extending through said piston body for operably communicating the interior of said first peripheral cooling galley with a source of cooling fluid; and

at least a second bore extending through said crown between said first peripheral cooling galley and



-18-

said second peripheral cooling galley for permitting cooling fluid to flow between said first and second peripheral cooling galleys.

5 5. A composite piston for an internal combustion engine as defined in claim 4 wherein said at least a second bore comprises:

at least two bores extending from said first peripheral cooling galley through said second rim portion of said crown and into said second peripheral cooling gallery.

10 6. A composite piston for an internal combustion engine as defined in claim 3 wherein:

the aspect ratio of said second peripheral cooling galley is approximately one..

15 7. A composite piston for an internal combustion engine as defined in claim 3 wherein:

the interior surface of said central longitudinal aperture of said piston body member and the exterior surface of said threaded fastener means forms a third peripheral cooling galley beneath said crown; and

20 third bore means extending between said second peripheral cooling galley and said third peripheral cooling galley for permitting cooling fluid to flow between said second and third peripheral cooling galleries.

25 8. A composite piston for an internal combustion engine comprising:



-19-

a generally cylindrical piston body formed from a relatively light weight material, said piston body having,

5 a central longitudinal aperture extending through said piston body,

a first seat peripherally fashioned about an upper and outer circumference of said piston body,

10 a second seat concentrically fashioned upon said piston body radially inward with respect to said first seat,

a third seat concentrically fashioned upon said piston body radially inward with respect to said second seat and radially outward with respect to said central longitudinal aperture; and

15 a piston crown having an upper and lower contoured surface and including,

an outer peripheral skirt including a first rim portion dimensioned to interferringly engage with said first seat of said piston body,

20 a second rim portion, positioned radially inwardly with respect to said first rim on the lower surface of said crown and being dimensioned to cooperate with said second seat of said piston body, and

25 a third rim portion concentrically positioned radially inward on the lower surface of said crown and being dimensioned to cooperate with said third seat of said piston body;



-20-

5 bolt means extending through said central aperture of said piston body and having a head portion operable to bear against a peripheral seat fashioned within said piston body around said central aperture and a threaded portion operable to engage a compatible threaded bore coaxially formed within the lower surface of said piston crown;

10 said first, second and third rim portions of said crown being axially dimensioned in a relaxed condition such that upon full seating of said first rim with said first seat an axial gap extends between said second rim and said second seat and a greater axial gap extends between said third rim and said third seat, and said threaded fastener means being operable
15 to sequentially draw said second rim into abutting engagement with said second seat and said third rim into abutting engagement with said third seat from a single central location to uniformly prestress said crown against said piston body and produce a compact
20 composite piston assembly operable to enhance the balance of the piston in operation without piercing the upper surface of said piston crown;

25 a first peripheral cooling galley formed beneath said piston crown by said first rim and said second rim and an axial surface of said piston body between said first seat and said second seat;

30 a second peripheral cooling galley formed beneath said piston crown by said second rim and said third rim and an axial surface of said piston body between said second seat and said third seat;

a first bore extending through said piston body for operably communicating the interior of said first



-21-

peripheral cooling galley with a source of cooling fluid; and

5 at least a second bore extending through said piston crown between said first peripheral cooling galley and said second peripheral cooling galley for per-
mitting cooling fluid to flow between said first and second peripheral cooling galleys.

9. A composite piston for an internal combustion engine as defined in claim 8 wherein:

10 the aspect ration of said second peripheral cooling galley is approximately one.

10. A composite piston for an internal combustion engine as defined in claim 98 wherein said at least a second bore comprises:

15 at least two bores extending from said first peripheral cooling galley through said second rim portion of said piston crown and into said second peripheral cooling galley.

11. A composite piston for an internal combustion
20 engine as defined in claim 8 wherein:

said upper surface of said piston crown having a peripheral zone with elevated segments and recessed segments to accommodate valve action of an internal combustion engine and said corresponding lower surface
25 of said piston crown beneath said peripheral zone generally following the contour of said upper surface such that the crown thickness is substantially uniform throughout said peripheral zone to minimize thermal stresses within said crown throughout said peripheral
30 zone.



-22-

12. A composite piston for an internal combustion engine as defined in claim 11 wherein:

5 the interior surface of said central longitudinal aperture of said piston body member and the exterior surface of said bolt means forms a third peripheral cooling galley beneath said crown; and

10 third bore means extending between said second peripheral cooling galley and said third peripheral cooling galley for permitting cooling fluid to flow between said second and third peripheral cooling galley.



FIG. 1

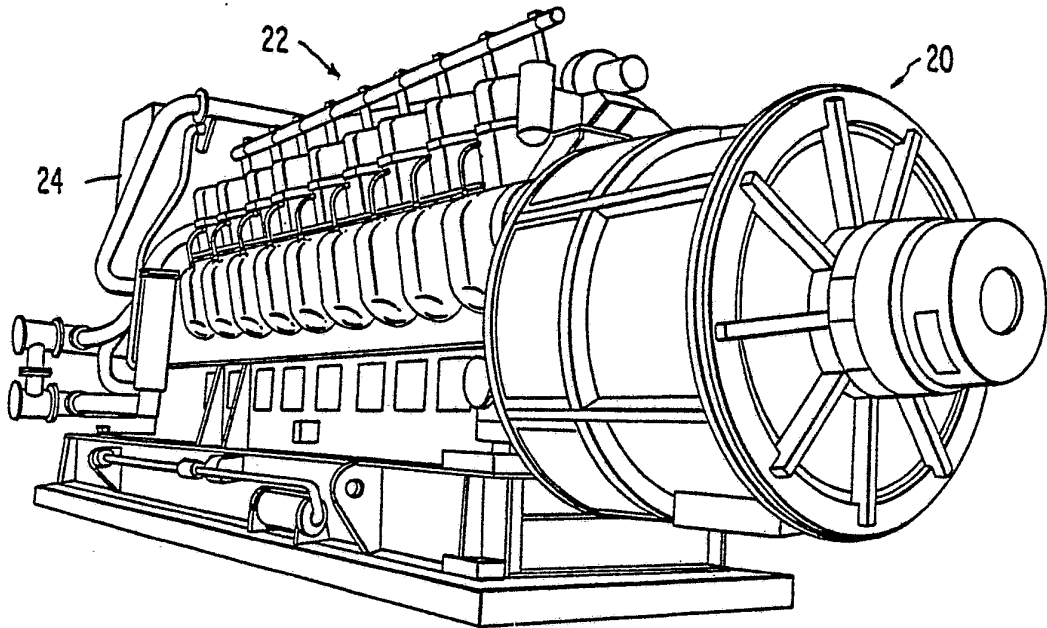
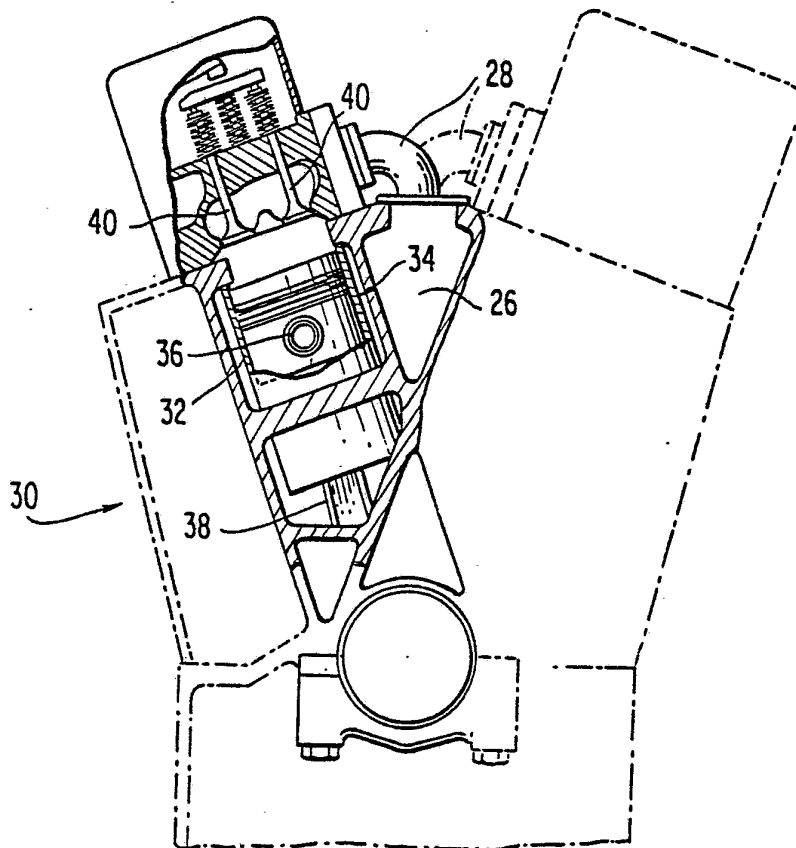

FIG. 2



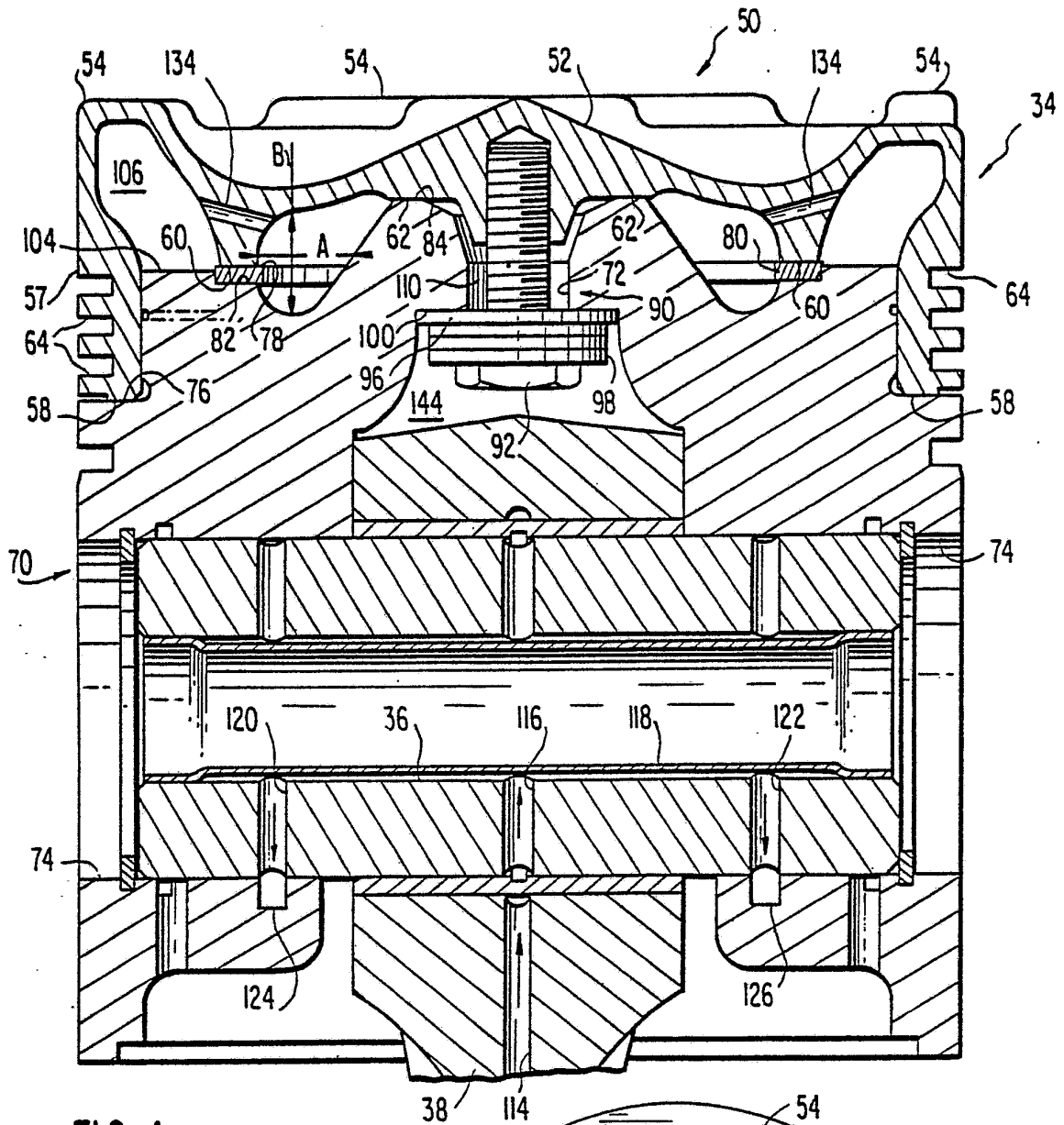

FIG. 4

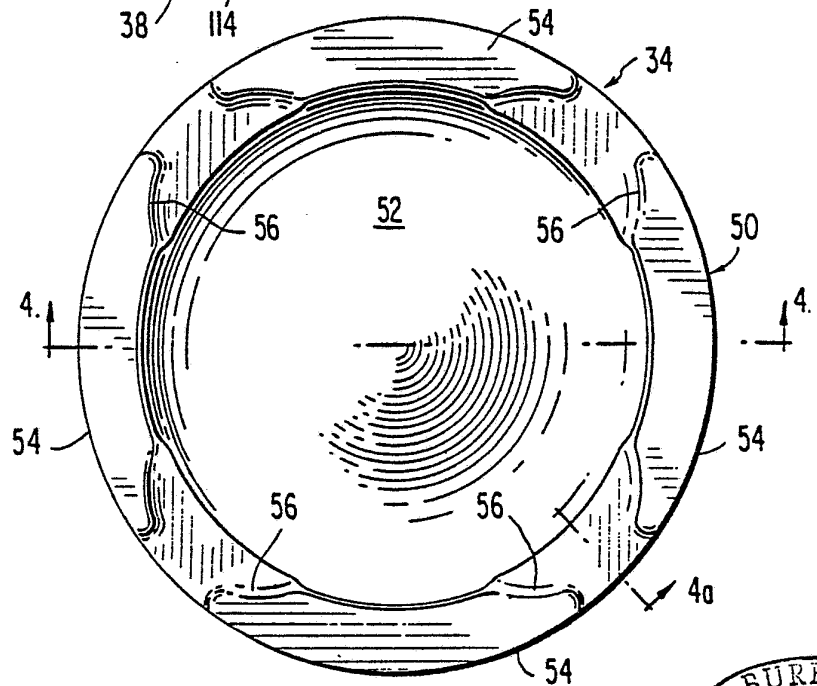

FIG. 3

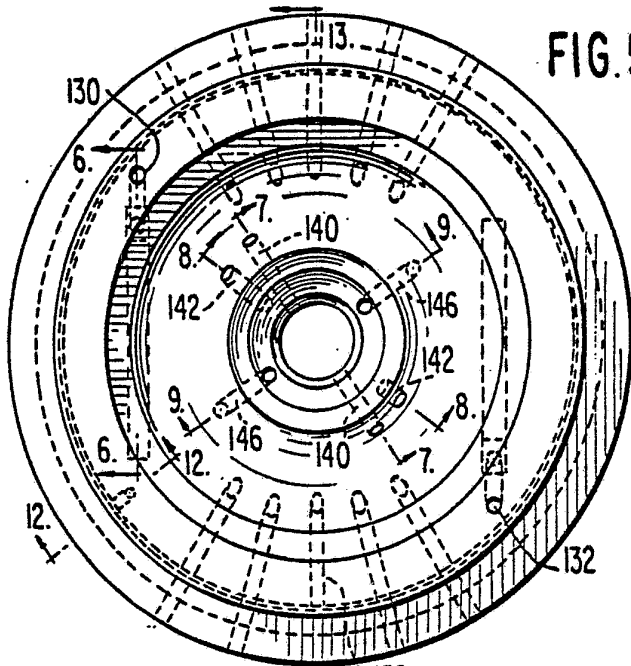

FIG. 5

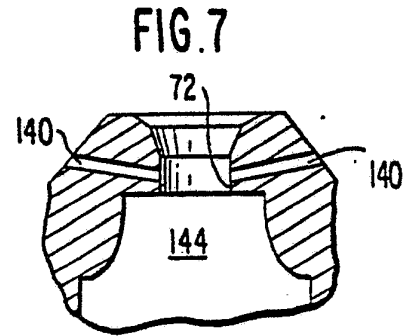

FIG. 7

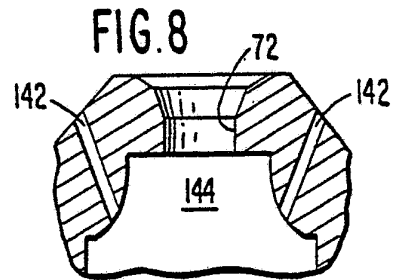

FIG. 8

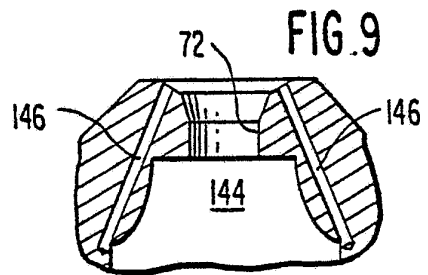

FIG. 9

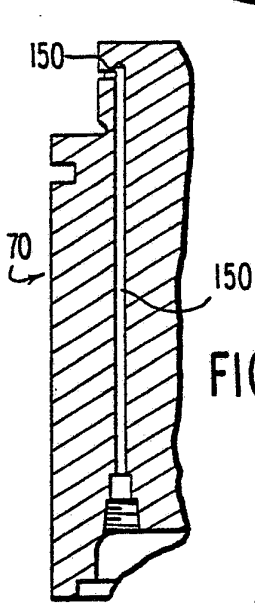

FIG. 12

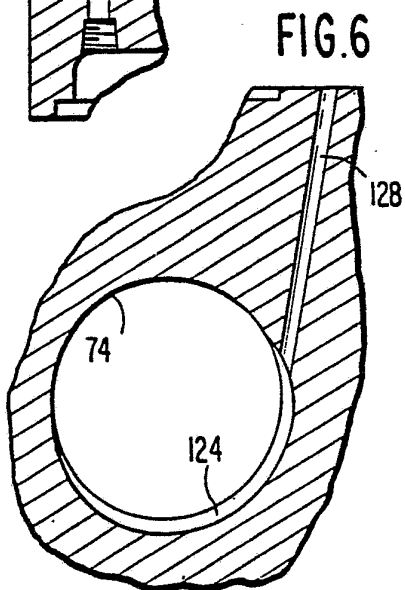

FIG. 6

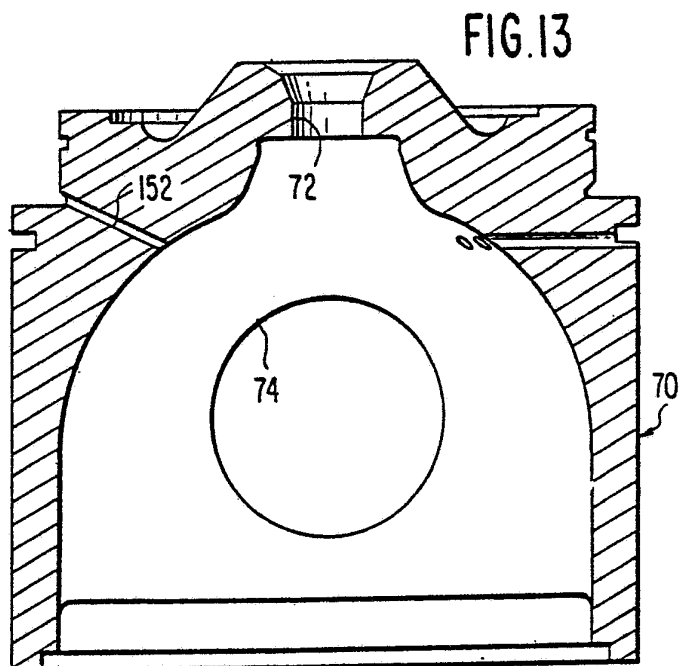
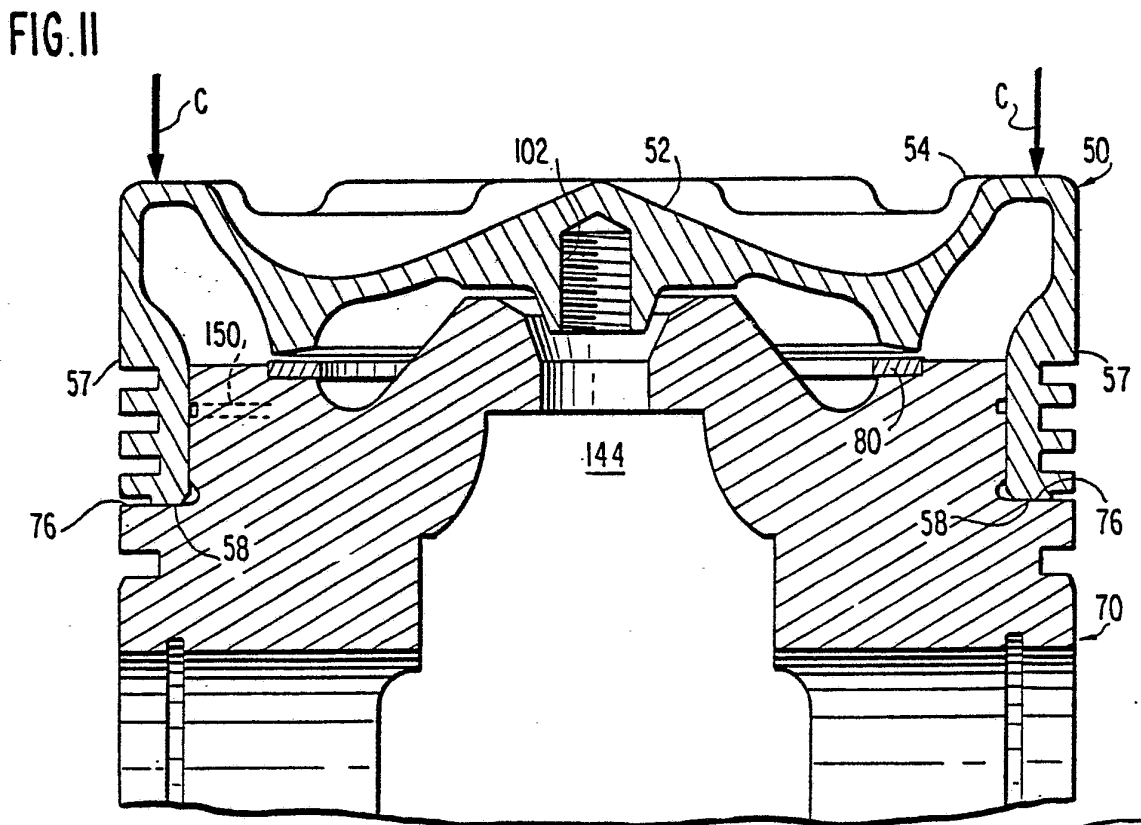
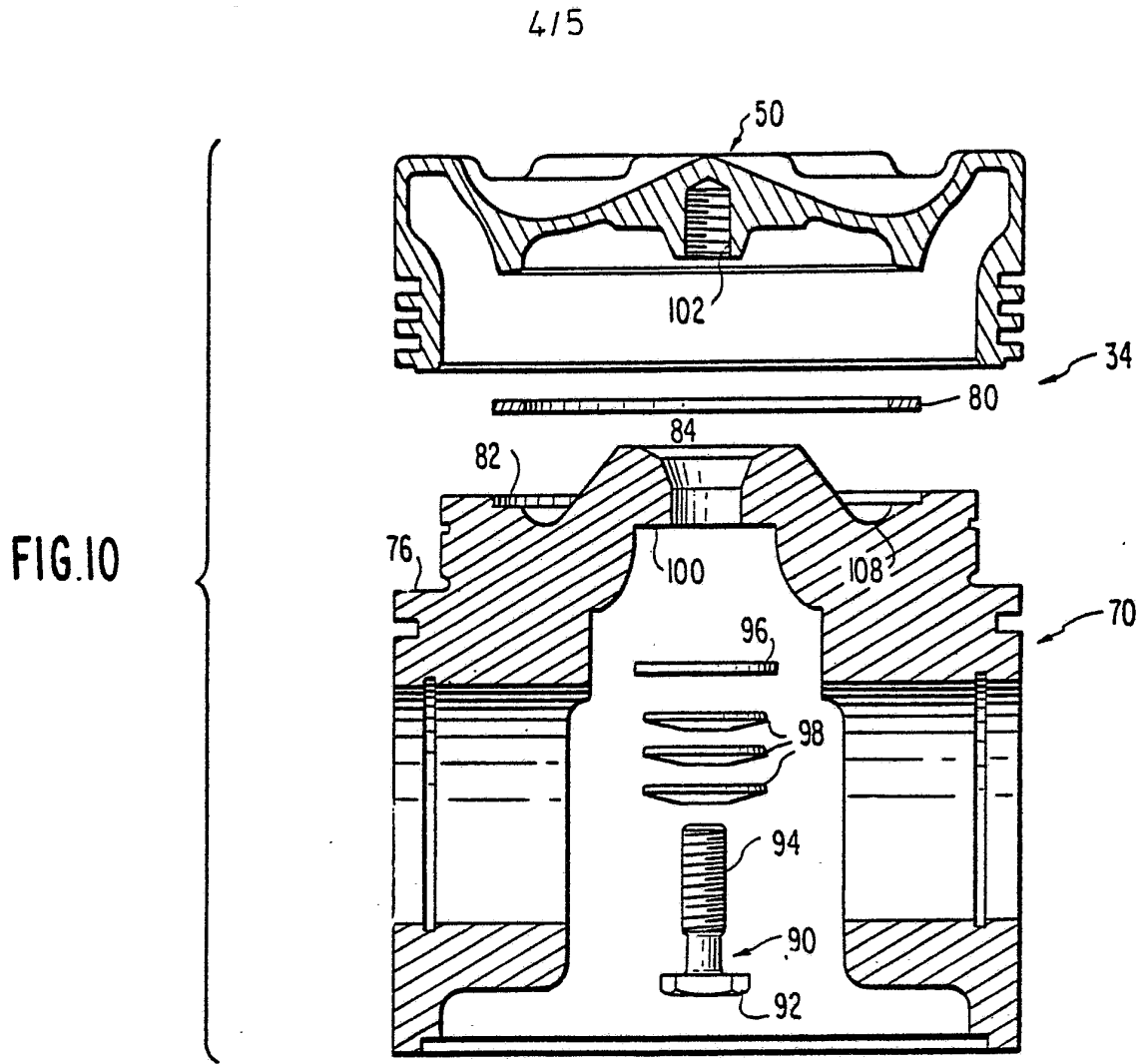

FIG. 13



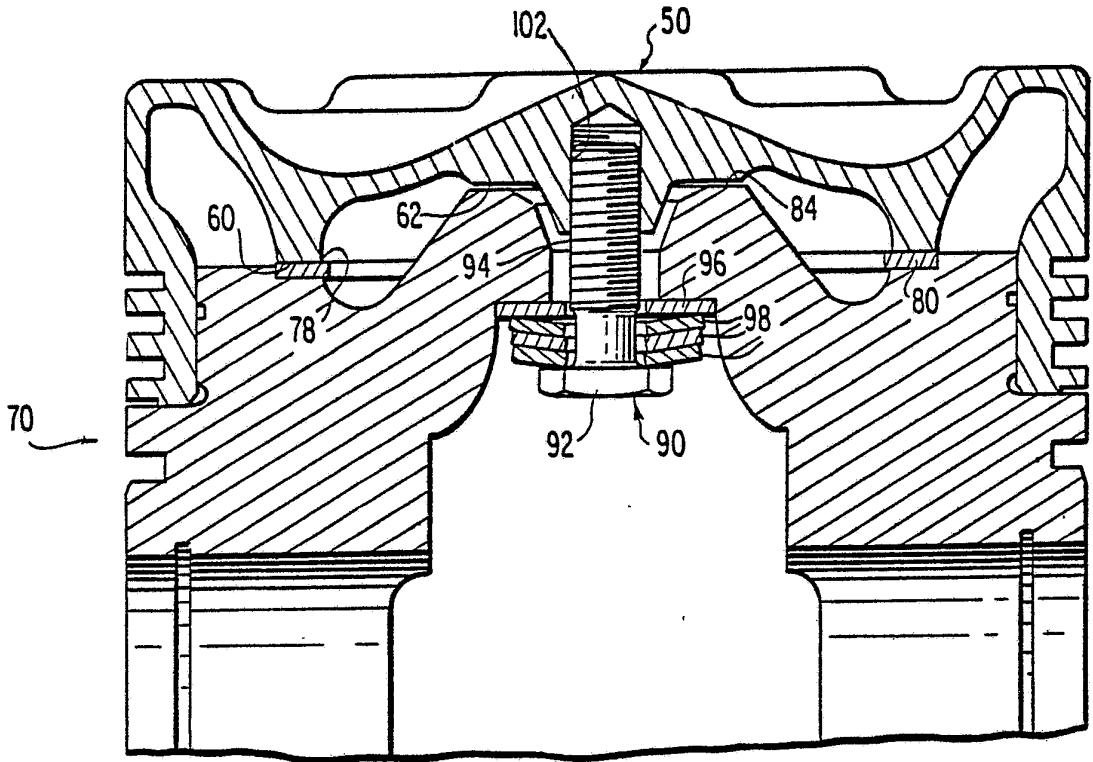
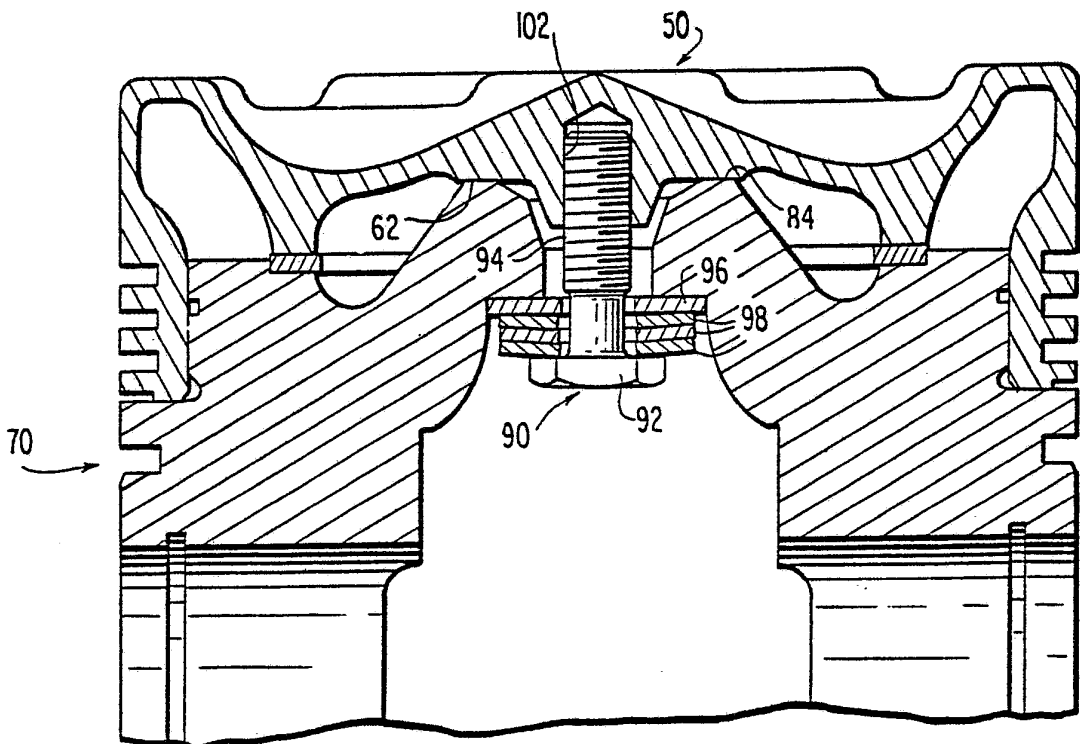

FIG. 14

FIG. 15



INTERNATIONAL SEARCH REPORT

International Application No **PCT/US 82/01760**

| I. CLASSIFICATION OF SUBJECT MATTER (if several classification symbols apply, indicate all) ³ | | |
|---|--|-------------------------------------|
| According to International Patent Classification (IPC) or to both National Classification and IPC | | |
| INT. CL. 3 | F01B 31/08 | F01P 3/10 |
| US CL. | 92/186,220 | 123/41.35 |
| II. FIELDS SEARCHED | | |
| Minimum Documentation Searched ⁴ | | |
| Classification System | Classification Symbols | |
| U.S. | 92/186,220,224,255,259,158,159, 123/41.35, 193P | |
| Documentation Searched other than Minimum Documentation to the Extent that such Documents are Included in the Fields Searched ⁵ | | |
| | | |
| III. DOCUMENTS CONSIDERED TO BE RELEVANT ¹⁴ | | |
| Category [*] | Citation of Document, ¹⁶ with indication, where appropriate, of the relevant passages ¹⁷ | Relevant to Claim No. ¹⁸ |
| Y | US, A 3,465,651 Published 9 Sep. 1969 Tromel | 8,9,10,12 |
| Y | US, A 4,083,292 Published 11 Apr. 1978 Goloff | 8,9,10,12 |
| A | US, A 1,373,263 Published 29 Mar. 1921 Regenbogen | 1,8 |
| A | US, A 1,778,064 Published 14 Oct. 1930 Calkins | 1,8 |
| A | US, A 2,619,392 Published 25 Nov. 1952 Brown | 1,8 |
| A | US, A 3,613,521 Published 19 Oct. 1971 Itano | 1,5,8,10 |
| A | US, A 4,114,519 Published 19 Sep. 1978 Speaight | 1,8,11 |
| A,P | US, A 4,356,800 Published 2 Nov. 1982 Moebus | 1,2,8 |
| <div style="display: flex; justify-content: space-between;"> <div style="width: 45%;"> <p>[*] Special categories of cited documents: ¹⁵</p> <p>"A" document defining the general state of the art which is not considered to be of particular relevance</p> <p>"E" earlier document but published on or after the international filing date</p> <p>"L" document which may throw doubts on priority claim(s) or which is cited to establish the publication date of another citation or other special reason (as specified)</p> <p>"O" document referring to an oral disclosure, use, exhibition or other means</p> <p>"P" document published prior to the international filing date but later than the priority date claimed</p> </div> <div style="width: 45%;"> <p>"T" later document published after the international filing date or priority date and not in conflict with the application but cited to understand the principle or theory underlying the invention</p> <p>"X" document of particular relevance; the claimed invention cannot be considered novel or cannot be considered to involve an inventive step</p> <p>"Y" document of particular relevance; the claimed invention cannot be considered to involve an inventive step when the document is combined with one or more other such documents, such combination being obvious to a person skilled in the art.</p> <p>"&" document member of the same patent family</p> </div> </div> | | |
| IV. CERTIFICATION | | |
| Date of the Actual Completion of the International Search ² | Date of Mailing of this International Search Report ² | |
| 8 March 1983 | 31 MAR 1983 | |
| International Searching Authority ¹ | Signature of Authorized Officer ²⁰ | |
| ISA/US | RICHARD KLEIN:dh | |