



US 20070163783A1

(19) **United States**

(12) **Patent Application Publication**
Head

(10) **Pub. No.: US 2007/0163783 A1**

(43) **Pub. Date: Jul. 19, 2007**

(54) **METHOD OF ABANDONING A WELL**

Publication Classification

(76) Inventor: **Philip Head**, West Drayton (GB)

(51) **Int. Cl.**
E21B 33/035 (2006.01)

Correspondence Address:

K.F. ROSS P.C.

5683 RIVERDALE AVENUE

SUITE 203 BOX 900

BRONX, NY 10471-0900 (US)

(52) **U.S. Cl.** **166/368**

(57) **ABSTRACT**

(21) Appl. No.: **10/576,799**

(22) PCT Filed: **Oct. 22, 2004**

(86) PCT No.: **PCT/GB04/04476**

§ 371(c)(1),

(2), (4) Date: **Feb. 8, 2007**

(30) **Foreign Application Priority Data**

Oct. 24, 2003 (GB) 0324823.4

A method of abandoning a well, said well comprising at least two concentric conduits (28,30) defining a main bore and at least one annular chamber (40) there between, comprising the steps of providing a perforation in one or more of the conduits, pumping out the fluid from the annular chamber and/or main bore to create a fluid-free void, inserting sealing material in the annular chamber and/or main bore to seal it/them. There is also provided an apparatus for abandoning a well having at least two concentric conduits defining at least one annular chamber there between, the apparatus including a pump (50) and a perforation forming device (42).

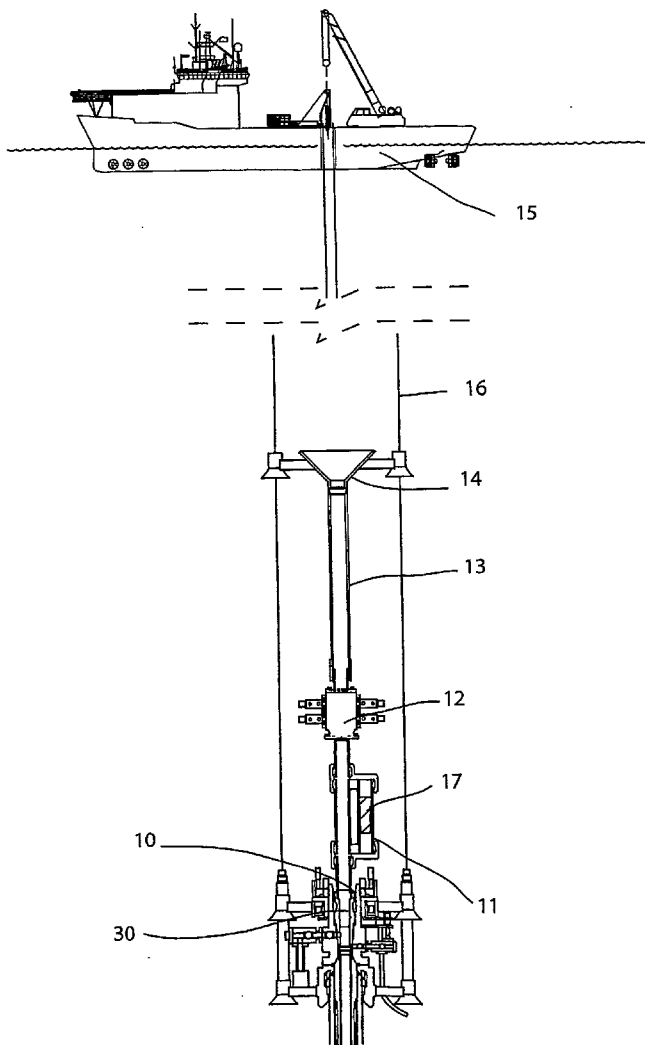

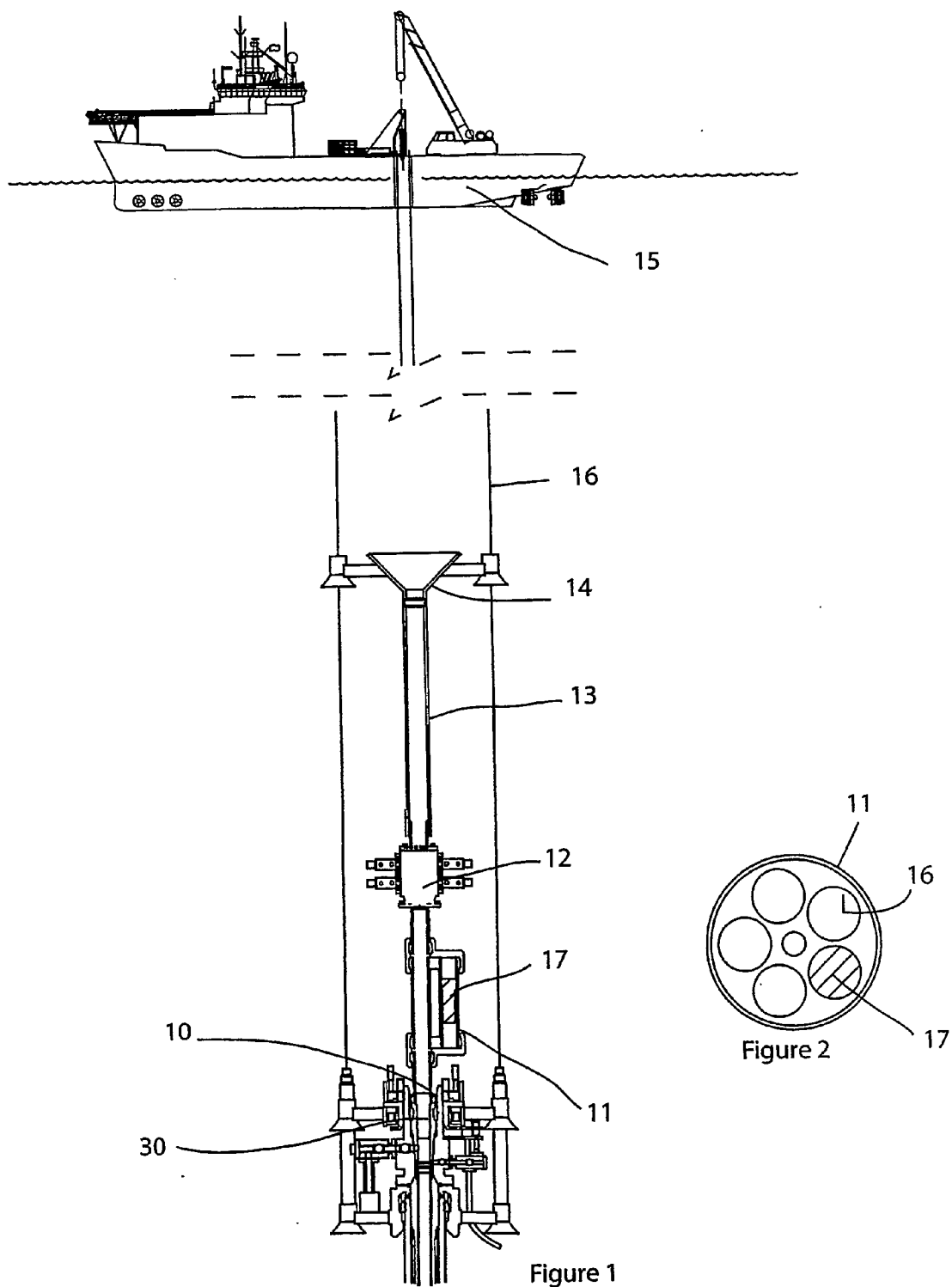

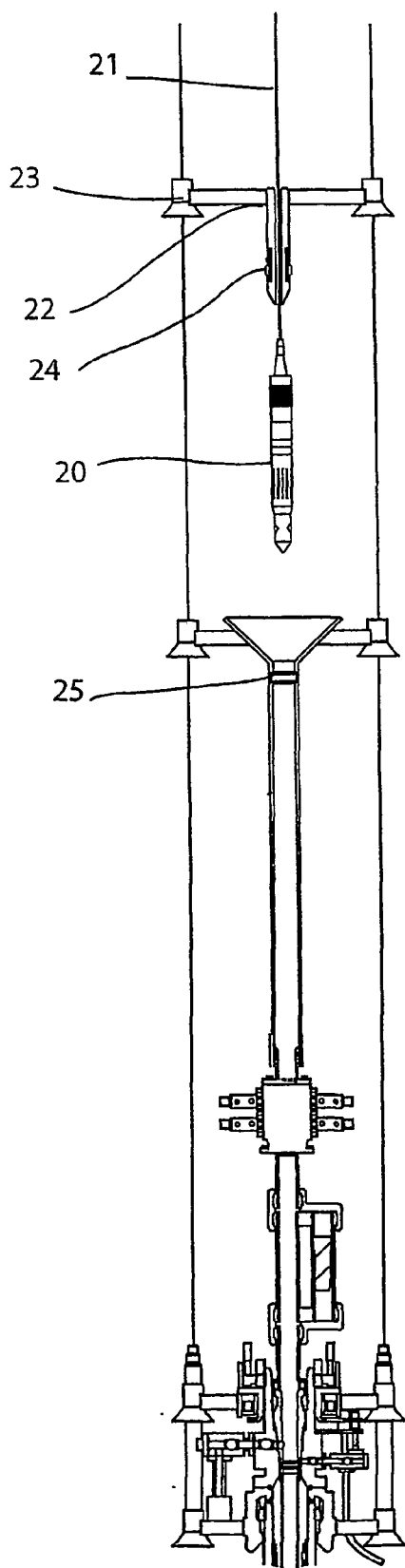

Figure 3

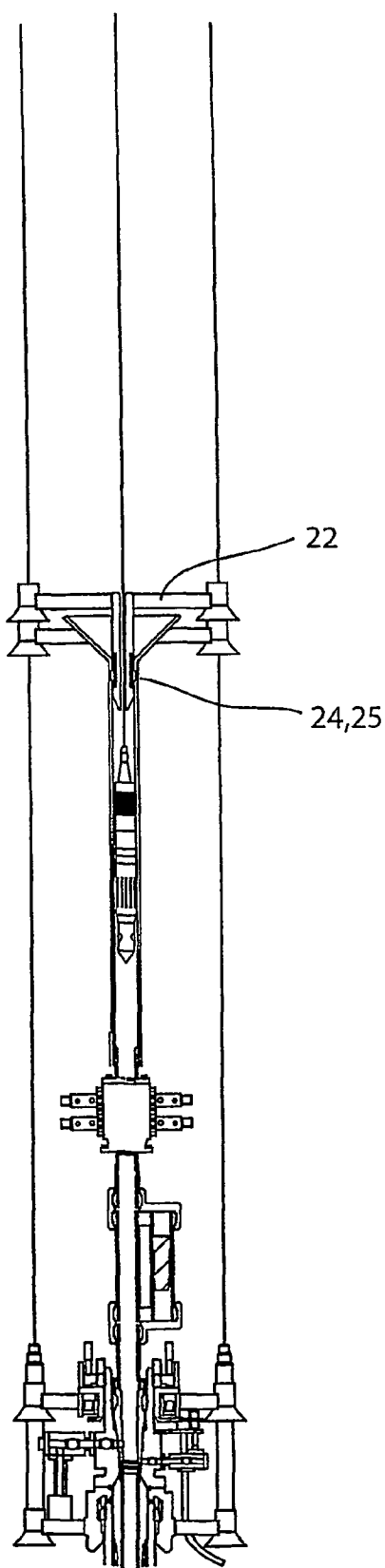

Figure 4

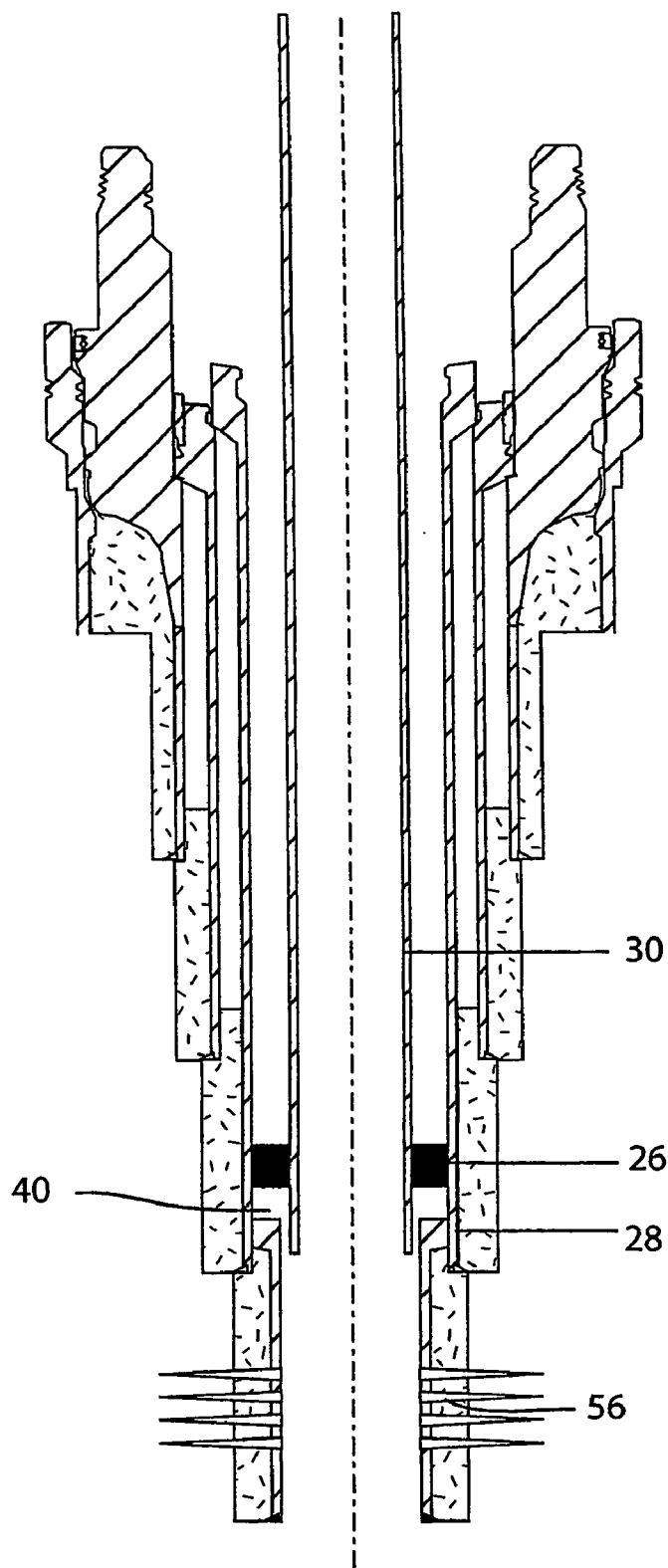

Figure 5

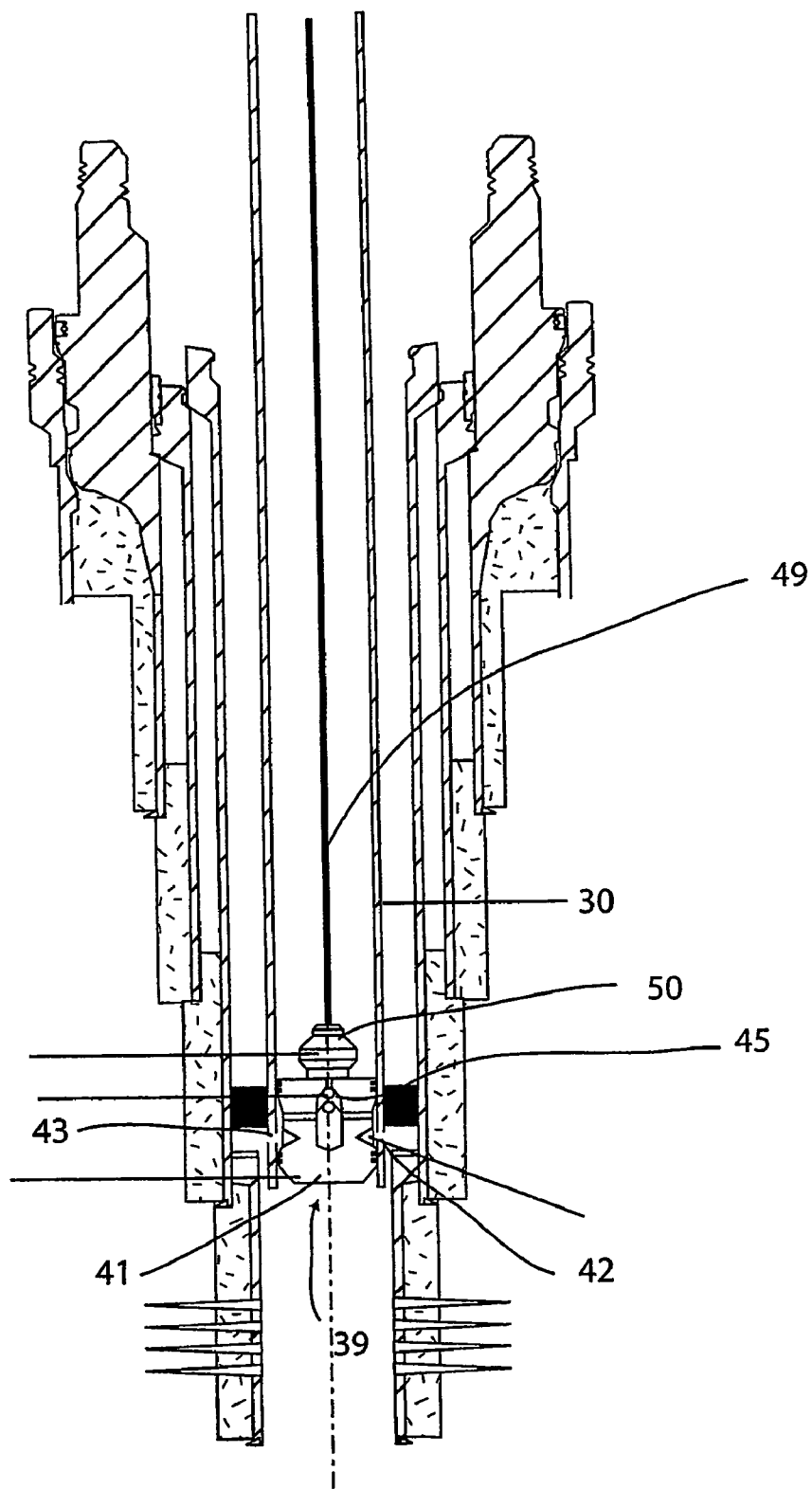

Figure 6

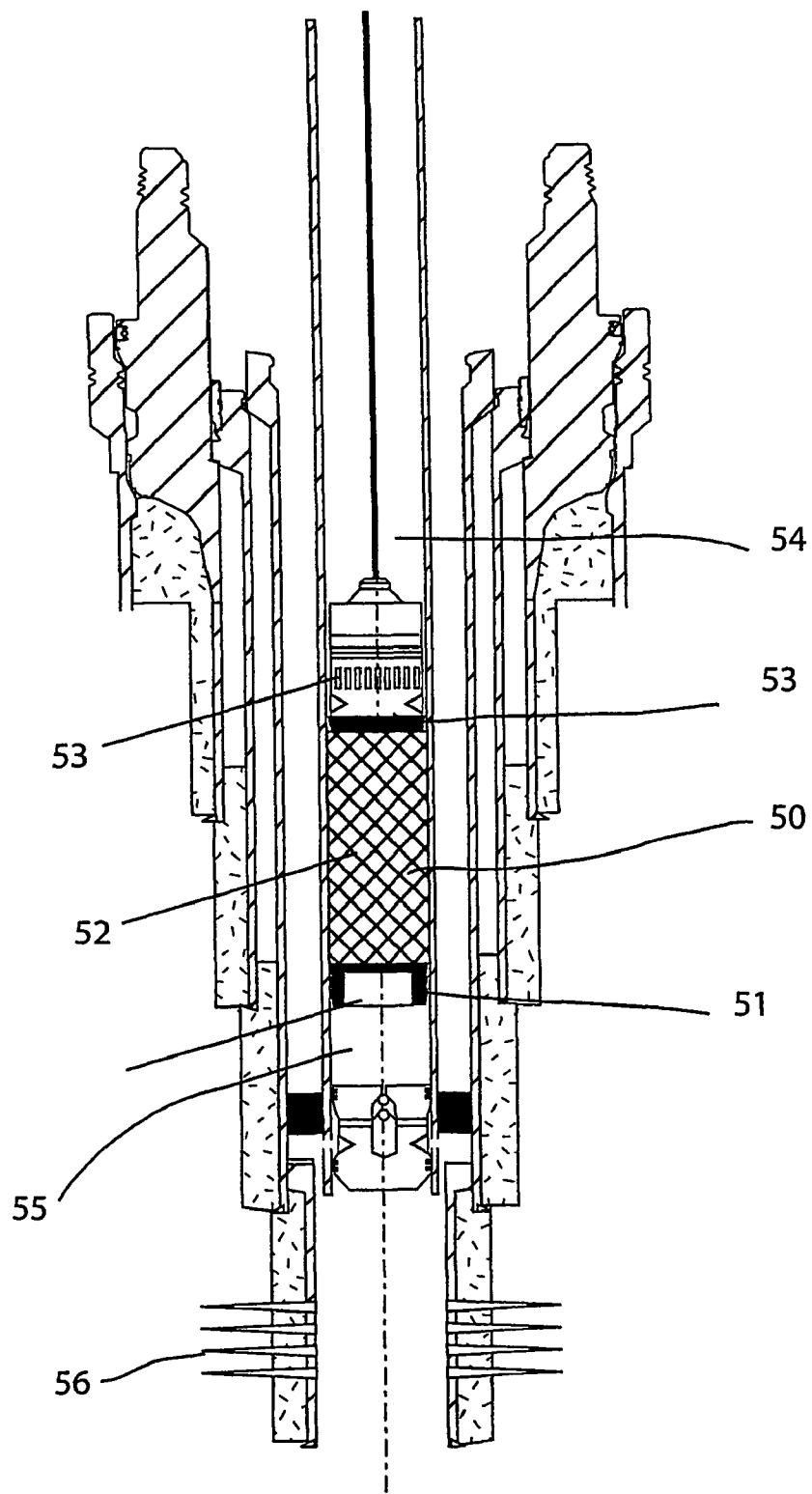

Figure 7

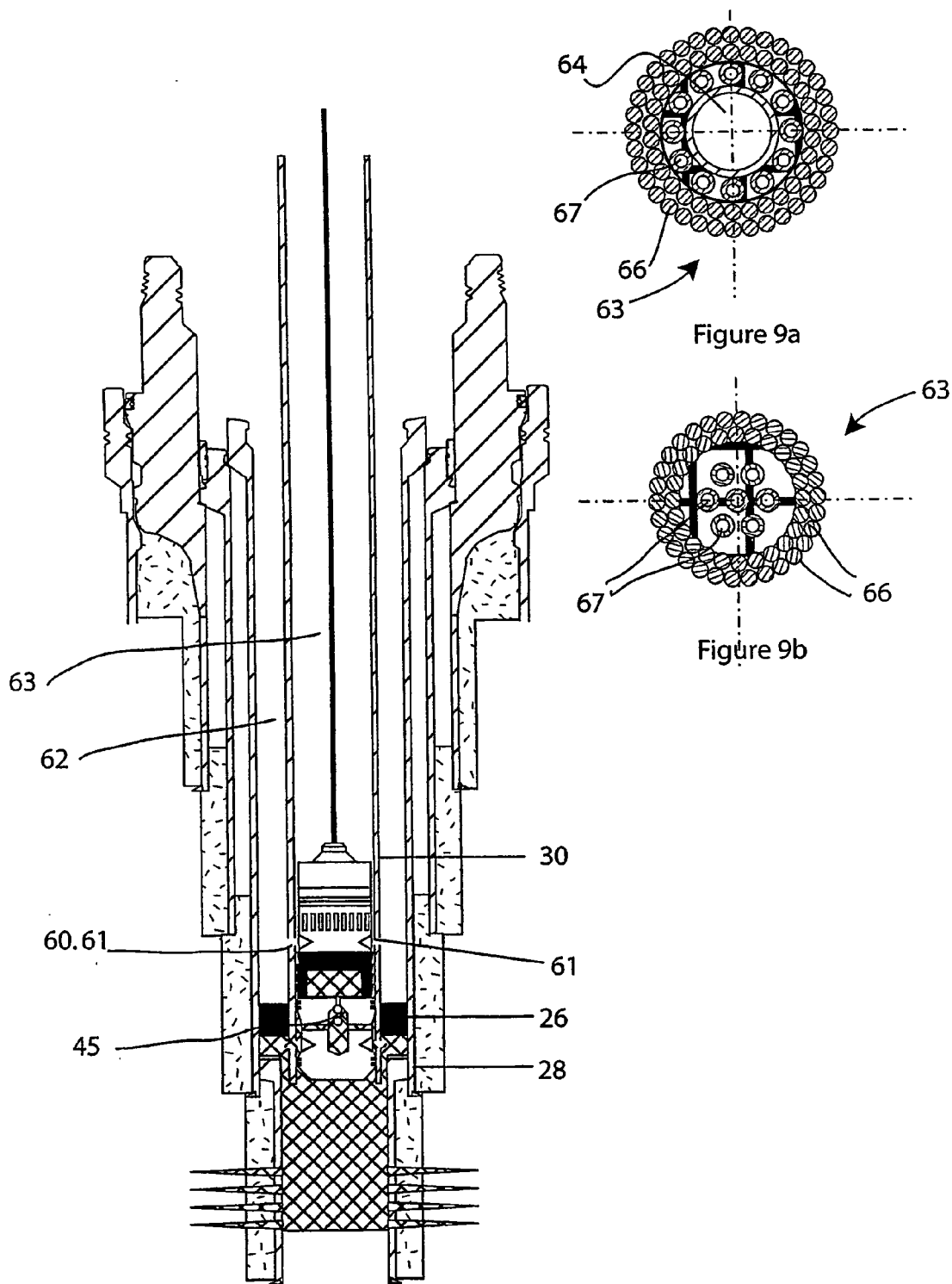

Figure 8

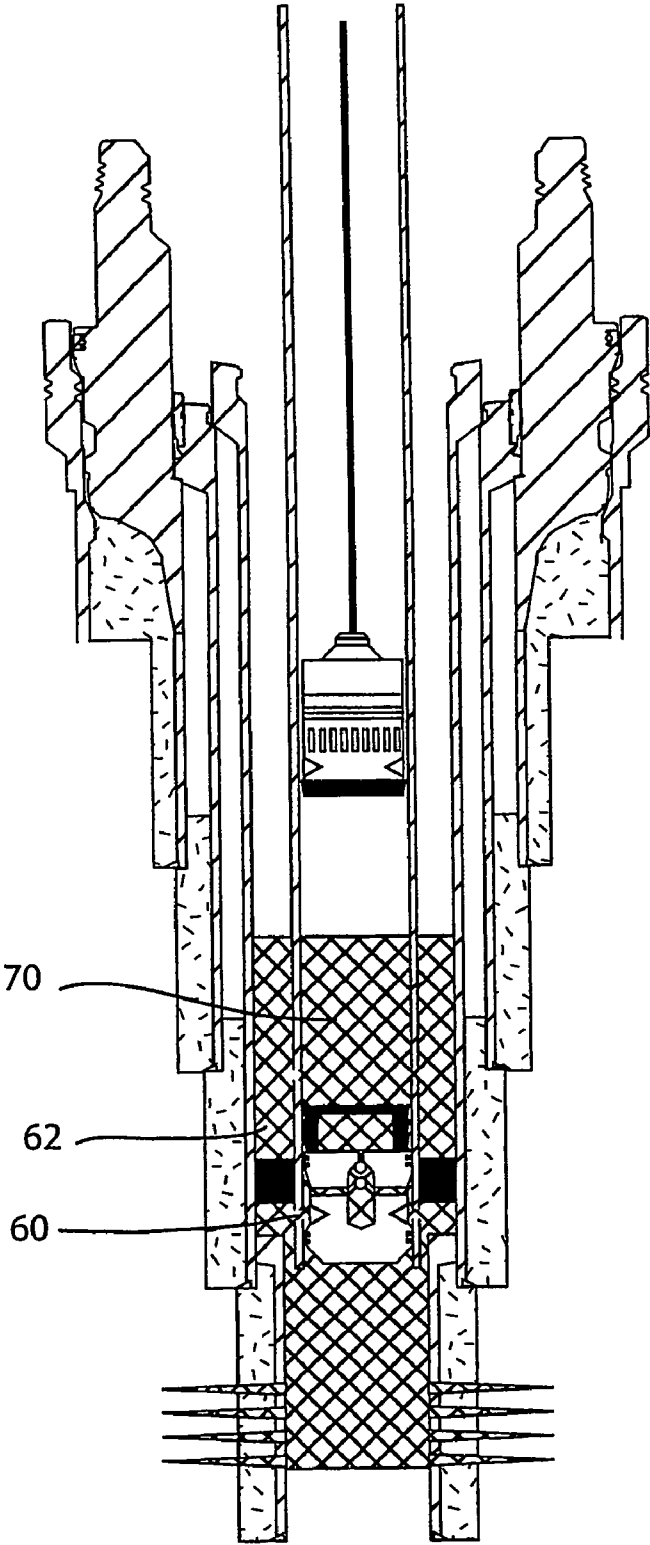

Figure 10

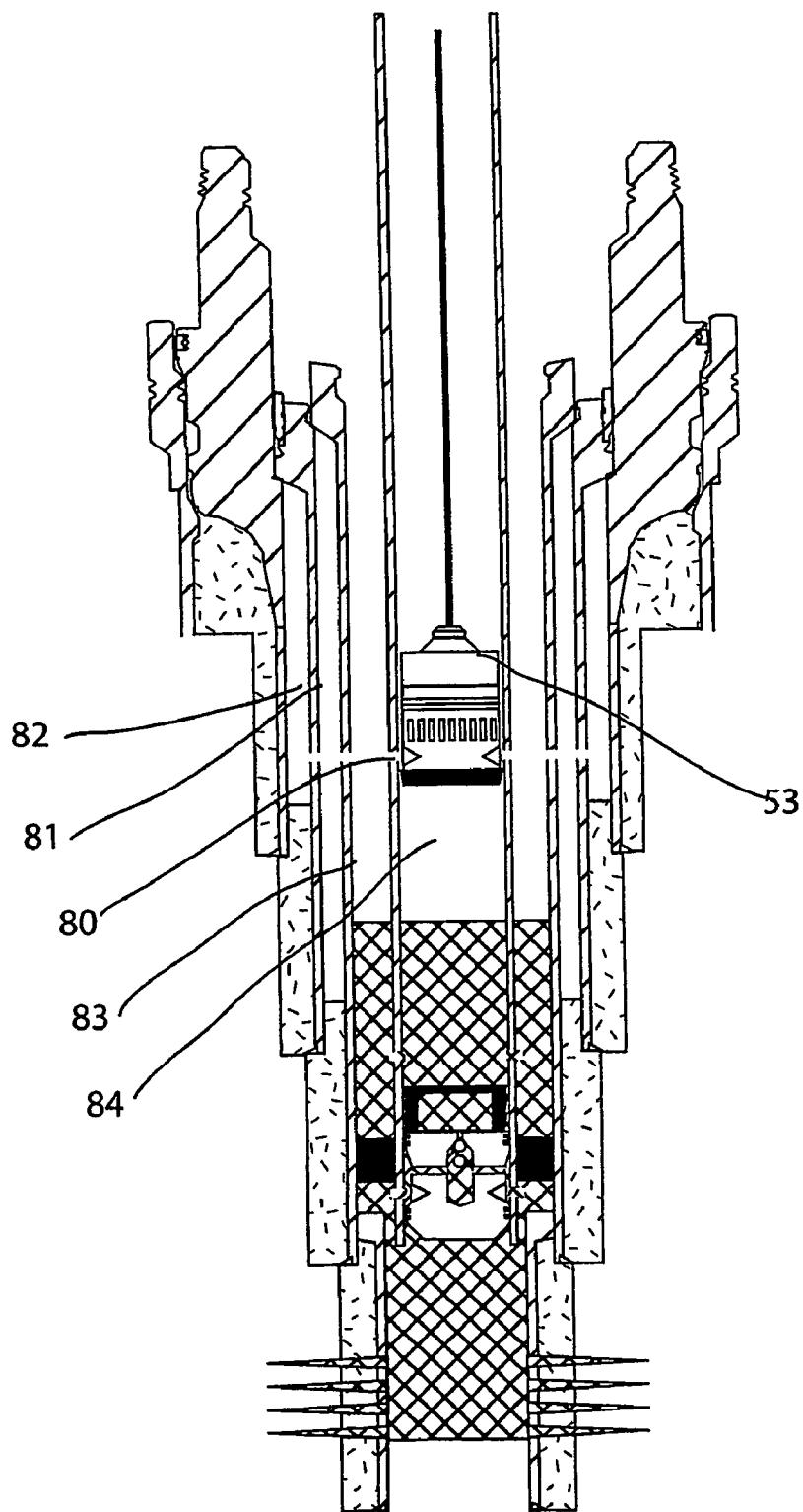

Figure 11

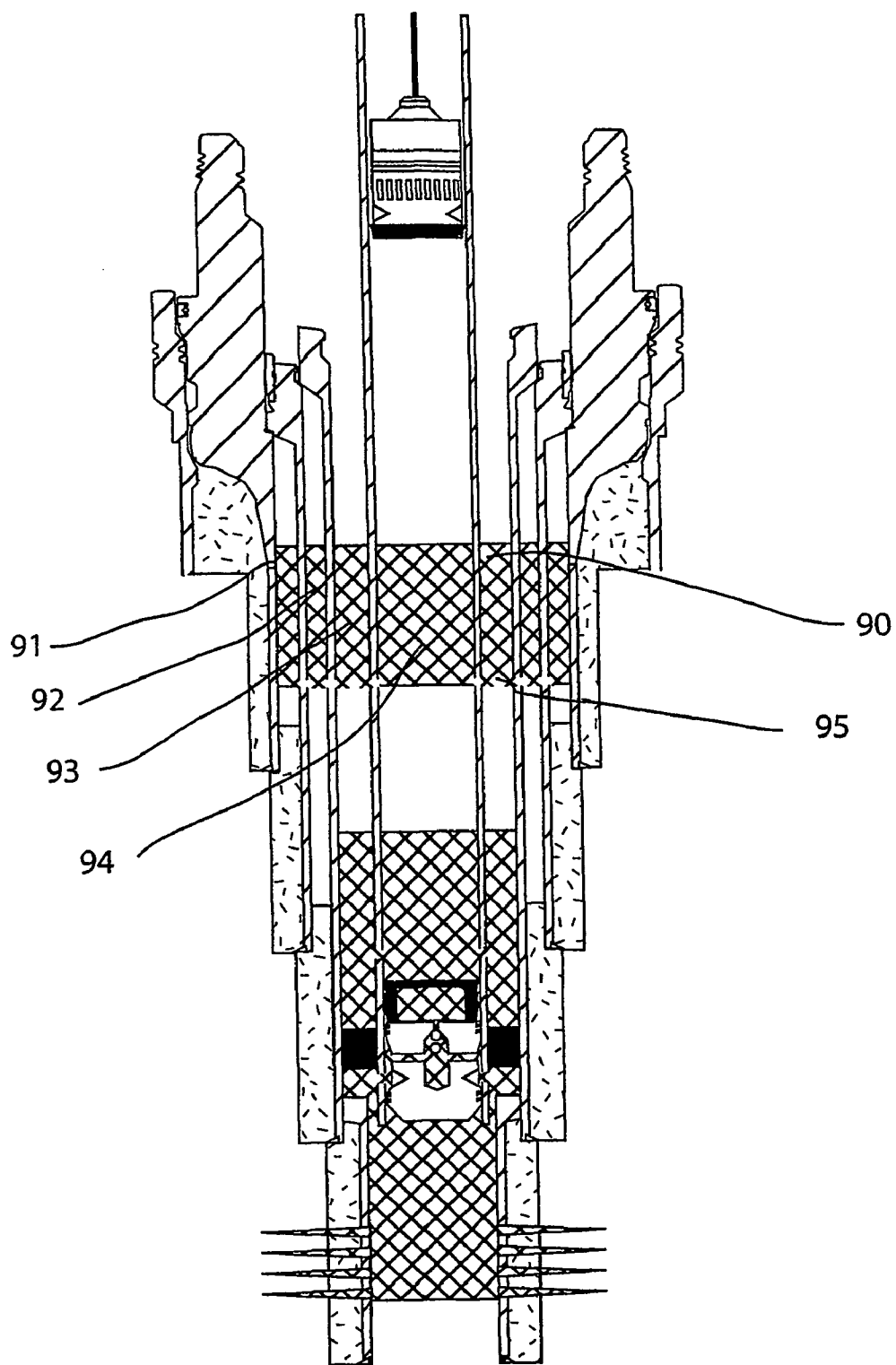

Figure 12

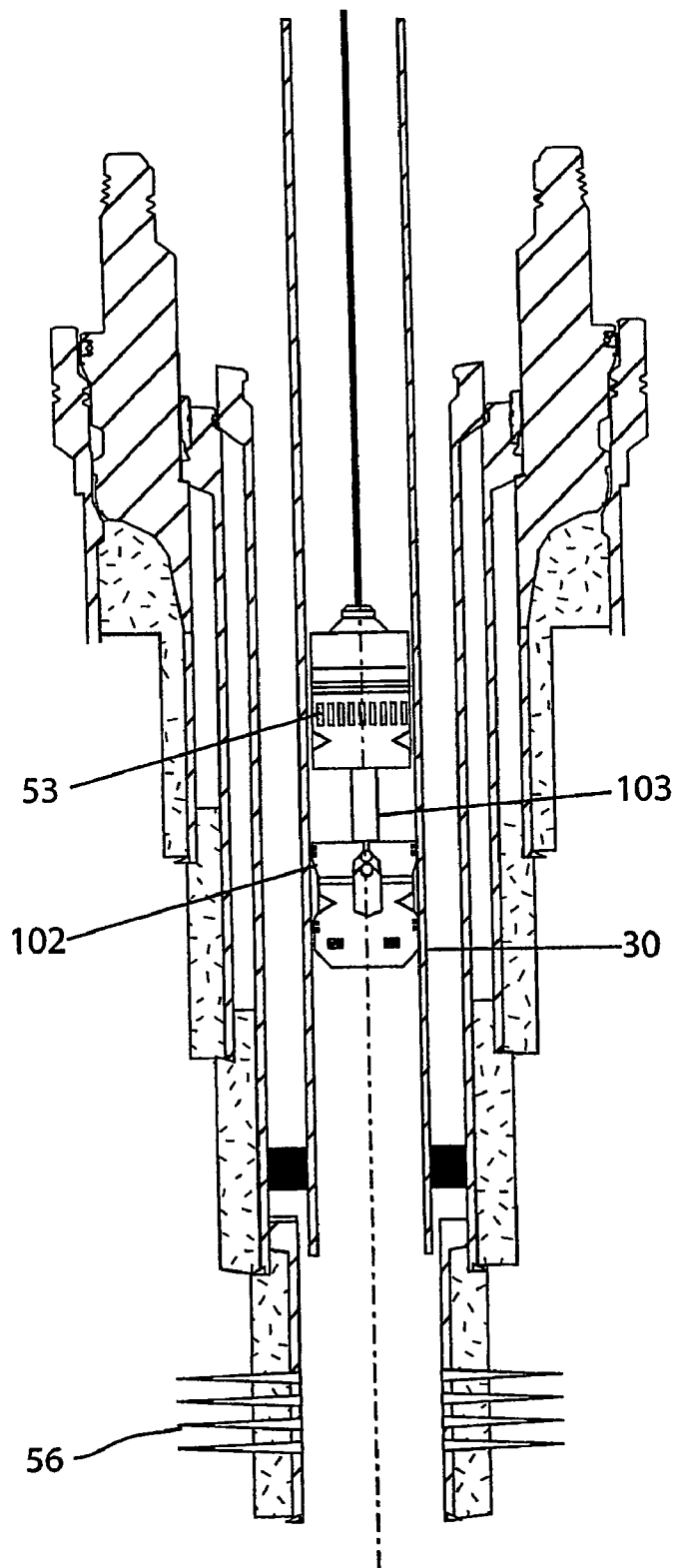

Figure 13

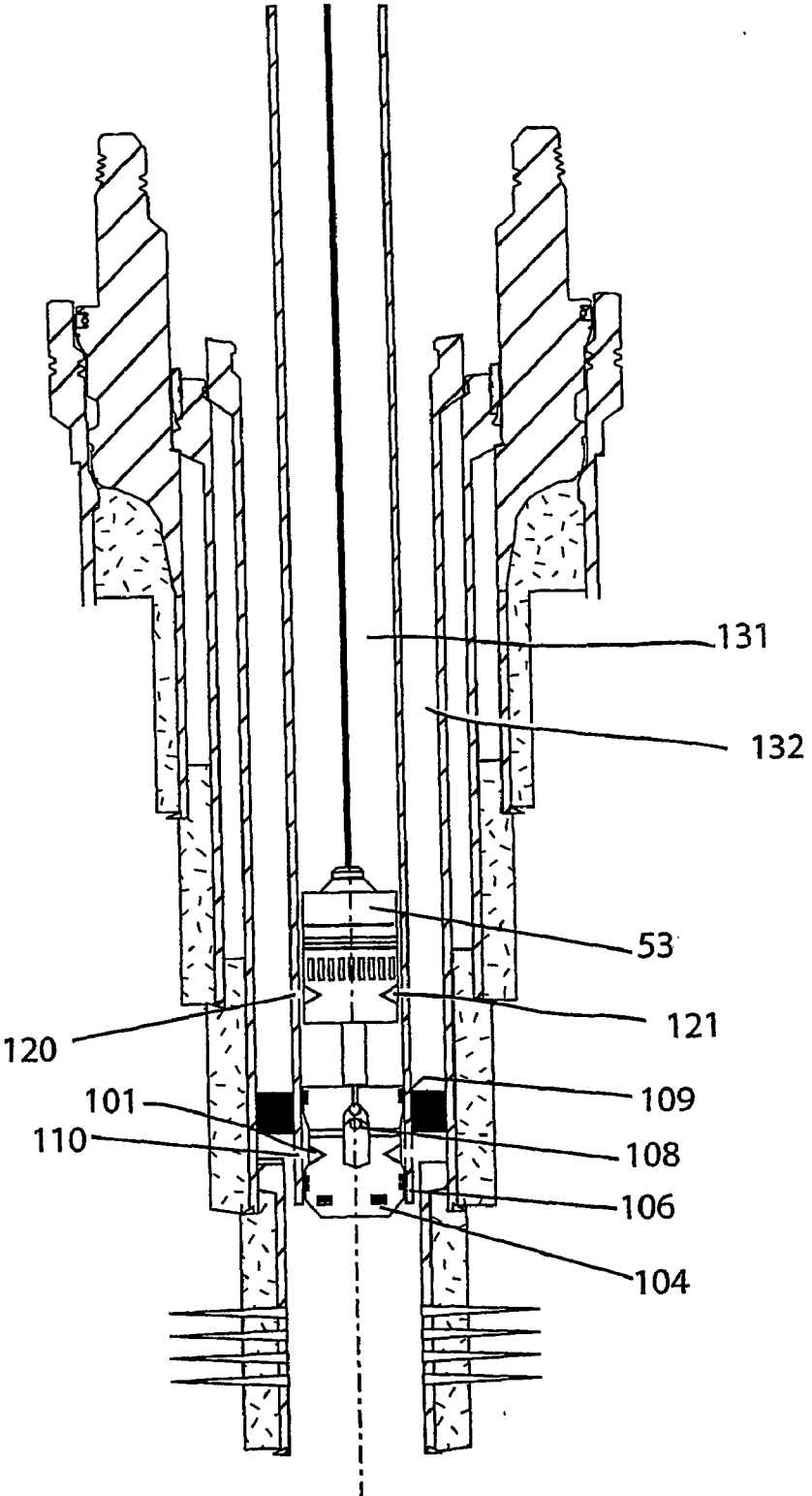

Figure 14

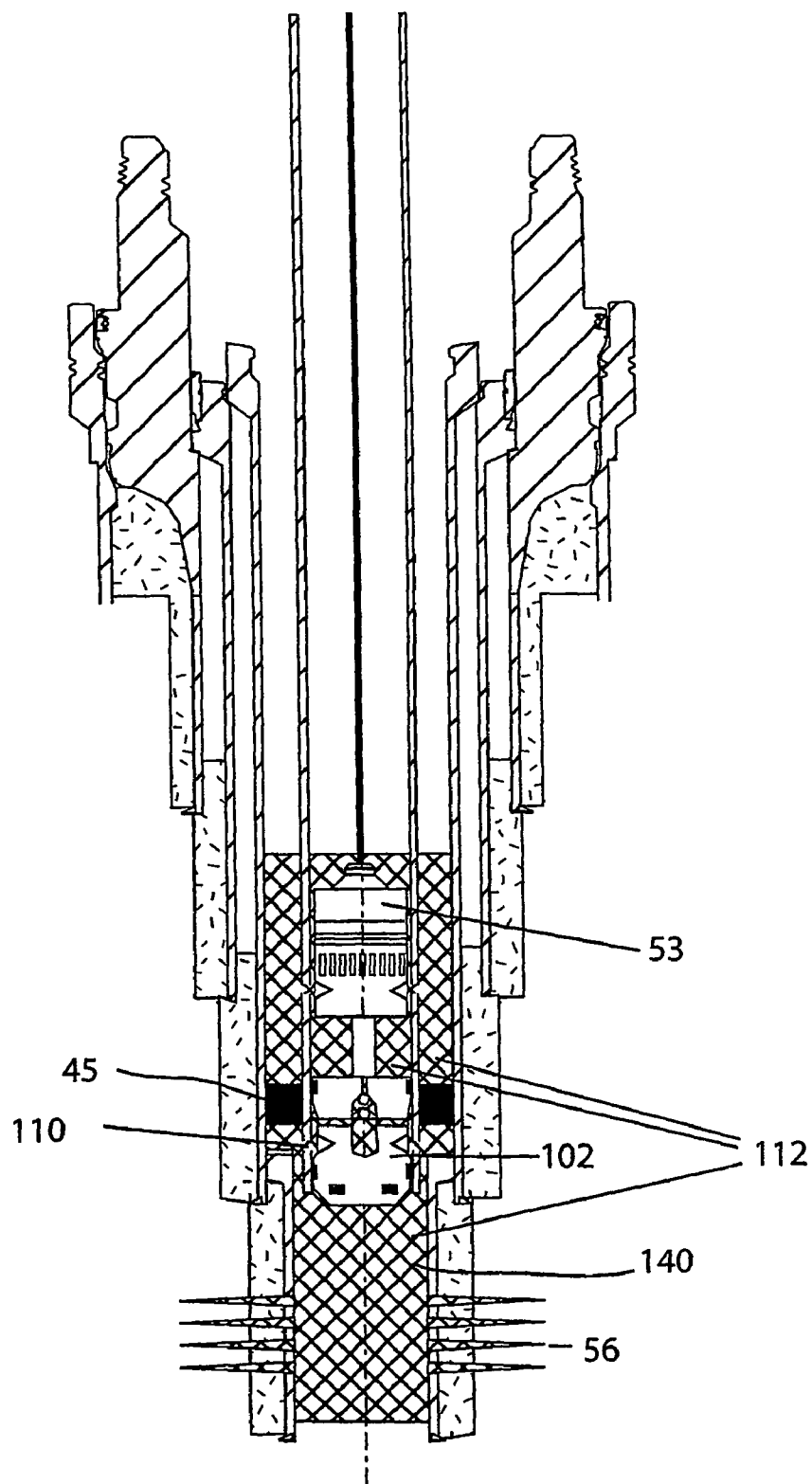

Figure 15

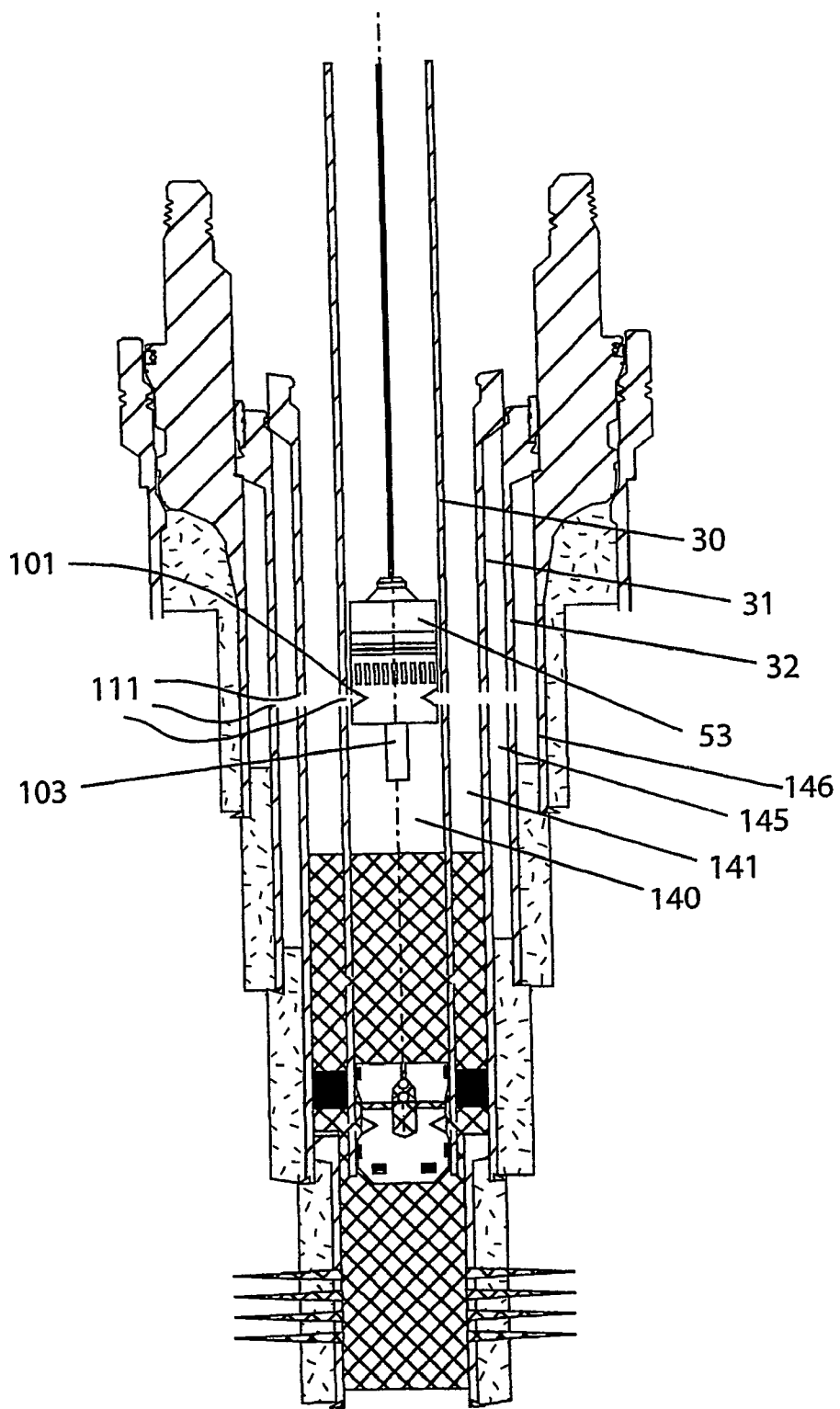

Figure 16

METHOD OF ABANDONING A WELL

[0001] Over the past 20 years or so a large number of offshore structures have been constructed which are now or will soon be exhausted and will need to be abandoned. These offshore structures may comprise production platforms which are either steel or concrete structures resting on the sea bed or floating platforms. Numerous conduits are connected to these offshore structures to carry the various fluids being gas, oil or water etc., which are necessary for the production of oil and/or gas from the well.

[0002] In abandoning a well, consideration has to be given to the potential environmental threat from the abandoned well for many years in the future.

[0003] In the case of offshore structure there is usually no rig derrick in place which can be used to perform the required well abandonment procedure. Therefore it is typically necessary to install a new derrick or alternatively a mobile derrick can be positioned above the well. This requirement adds considerable expense to the task of abandoning the offshore well, compared to a land based well.

[0004] A typical production well will comprise a number of tubular conduits arranged concentrically with respect to each. The method of abandoning the well which is presently known in the art involves the separate sealing of each of the concentric conduits which requires a large number of sequential steps.

[0005] In the abandonment method known in the art the first step is to seal the first central conduit usually by means of cement or other suitable sealant. The first annular channel between the first and second conduits is then sealed and the first central conduit is then cut above the seal and the cut section is removed from the well.

[0006] The second annular channel between the second and third conduits is then sealed and the second conduit cut above the seal and the cut section is removed from the well.

[0007] This process is repeated until all the conduits are removed. The number of separate steps required is typically very large indeed and the number of separate operations is five times the number of conduits to be removed. This adds considerably to the cost of the well abandonment due to the time taken and the resources required at the well head.

[0008] It is the purpose of the present invention to provide a method of abandoning a well which avoids the disadvantages and numerous operations which are required by the existing known methods. This will greatly reduce the costs of safely abandoning a well. It is a further objective of the invention to provide a method of abandoning a well without the requirement of a rig which involves significant expense particularly in sea based wells.

[0009] It is a further advantage of the invention to isolate all the conduits and annuli with no return of the well bore or annular fluids to the surface. Additionally if required all tubing and casing can remain in the well. Further more the method of abandonment of the well will comply with all the regulatory guidelines for the isolation of a well.

[0010] According to the present invention there is provided a method of abandoning a well, said well comprising at least two concentric conduits defining a main bore and at least one annular chamber there between, comprising the steps of:

[0011] providing a perforation in one or more of the conduits,

[0012] pumping out the fluid from the annular chamber and/or main bore to create a fluid-free void,

[0013] inserting sealing material in the annular chamber and/or main bore to seal it/them.

[0014] According to another aspect of the present invention there is provided an apparatus for abandoning a well having at least two concentric conduits defining at least one annular chamber there between, the apparatus including a pump and a perforation forming device.

[0015] Thus by means of the method according to the invention the number of operations required is greatly reduced thus resulting in a considerable reduction in the cost of carrying out the well abandonment.

[0016] The following is a more detailed description of an embodiment according to invention by reference to the following drawings in which:

[0017] FIG. 1 is a side view of a typical subsea well showing a vessel situated over it and with a well intervention package attached.

[0018] FIG. 2 is a plan view of the multi barrel storage and launching assembly, located above the wellhead and below the blow out preventors.

[0019] FIG. 3 is a side view of the wellhead, with a well intervention system connected and a tool assembly being lowered from the vessel above.

[0020] FIG. 4 is a side view of the wellhead, with a well intervention system connected and a tool assembly installed in the pressure vessel (lubricator) section of the well intervention package.

[0021] FIG. 5 is a cross section of a well showing the typical components and their relative depth.

[0022] FIG. 6 shows the same cross section of the well as the figure above, but with a tool assembly lowered to its tailpipe

[0023] FIG. 7 shows the same cross section of the well as the figure above, displacing fluid into the reservoir section and lowering an electric pump

[0024] FIG. 8 shows the same cross section of the well as the figure above, the lower tubing and tubing annuli evacuated of fluid by the electric pump.

[0025] FIG. 9a shows a cross section of the umbilical power cable

[0026] FIG. 9b shows a cross section of the umbilical power cable of another embodiment of the well system, shown in FIGS. 13 to 16

[0027] FIG. 10 Shows the lower voids filled with sealing material

[0028] FIG. 11 shows the electric pump and hole making system moved up the well and new holes perforated through all the sections of casing

[0029] FIG. 12 shows all the annuli perforated, voided of fluid by allowing to flow to the sump below and by using the electric pump, and finally filled with sealing material

[0030] FIGS. 13 to 16 shows the stages of another embodiment of the method.

[0031] Referring to the figures in more detail, FIG. 1 to 4 shows the well intervention package. This consists of a wellhead connector adaptor 10, an optional wellhead plug retrieval and plug launcher carousel 11 fitted directly above this, blow out preventors 12, high pressure wellbore extension (more commonly known as the lubricator) 13, and a funnel guide 14 to provide easy access for the tools when lowered from the vessel 15. Guide lines 16 are shown, but are not essential. A tool assembly 20 is prepared on the vessel and lowered on an umbilical 21. It is also lowered with the dynamic umbilical seal 22, a guide means 23 and a method of docking and retaining itself 24 into an internal profile 25 at the top of the lubricator 13. The wellhead plug 30 ensures the well is safe for normal production operations, but can be removed to enable the well to be accessed. A tool can either be activated from the tool carousel 11 or lowered from the vessel. In either case the plug 17 can be stored in one of the empty barrels 16 of the tool carousel. This saves considerable tripping time for the operating tool 20.

[0032] FIG. 5 to 12 shows the well abandonment process in greater detail. The main objectives are to isolate all zones and casing annuli with a multi interval 100% permanent seal or seals, prohibit the return of well bore hydrocarbon fluids to surface, eliminate the need to pull out of the well the production tubing and disposal of it. How this is achieved is described as follows.

[0033] FIG. 5 shows a well which is to be abandoned and made safe by the method and apparatus described herein. The well has production tubing 30 installed above the production perforations 56, the production tubing being sealed from an annulus by a production packer 26. If required, to ensure a good sealing, material may be placed in the annular area 40 around the tailpipe, then a tailpipe seal 41 is lowered on an umbilical and it is landed in a tailpipe nipple (not shown) to hold it in place. This is not essential, but it provides an ideal sealing and anchor point.

[0034] As shown in FIG. 6 a seal assembly 39 is provided includes a tailpipe seal 41 at its lower end which plugs the end of the production tubing 30. The seal assembly 39 includes a hole making system such as a perforating charge 42. This is used to make holes 43 in the tailpipe to permit the flow of the existing well fluids therethrough. The tailpipe seal also has a dual check valve 45 to provide a means permitting flow from the production tubing into the lower part of the well and of preventing fluid from flowing back into the production tubing. This dual check valve is preferably mechanical, which may in its simplest form be a spring loaded ball biased against a sealing seat. The seal assembly 39 is lowered into position by means of a conveyance tool 50, suspended from the end of an umbilical 49. After the seal assembly is fixed in position the umbilical 49 and conveyance tool 50 are recovered back to surface.

[0035] Referring now to FIG. 7 a pump assembly 50 is then lowered down the main bore production. The pump

assembly includes a pump 53 below which is provided tube holing means and below the holing means well sealing material 52 is provided. At the lowermost end of the well sealing material a bottom plug 51 is provided. The pump assembly is forced down the production tubing by the pressure of a displacement fluid provided above the pump assembly. The displacement fluid could be seawater or even nitrogen. The bottom plug 51 seals against the internal wall of the production tubing so that the contents of the production tubing 55 are then displaced back into the lower part of the well and into the reservoir through the reservoir perforations 56. When the pump assembly has been completely pushed down to the check valve 45, the well sealing material has passed through the plug assembly and into the lowermost part of the well. This sealing material cures in time and provides a permanent seal of the formation.

[0036] Holes are made in the production tubing 30, by the holing means. This could be any suitable holing means such as by using perforating charges 61. This is shown in FIG. 8. The pump is now activated and the pump causes the displacement fluid in the production tubing 63 to be pumped upwards through the bore in the umbilical 63 and out of the well and the fluids in the annulus 62 correspondingly drain into the production tubing and are similarly pumped out of the well up the umbilical 64 until all the fluid in annulus 62 is removed. There will be a small remainder of fluid in the annulus below the level of the perforations 60. FIG. 9a shows the structure of the umbilical 63, comprising an outer armoured supporting layer, and an inner layer of lower cables 67 surrounding the bore 64. FIG. 9

[0037] Whilst in this embodiment the plug, sealing, holing and pumping actions are carried out in that particular sequence using a single pump assembly tool, it is also possible to use separate tools for the separate steps and variations to the sequence.

[0038] For example, the sealing material could be provided after the holing of the production tubing. The fluids could then be pumped downwards into the reservoir section also instead of outwards to surface, before a sealing material is placed behind them. This would avoid the need to make separate arrangements for the disposal of the fluids pumped out.

[0039] Referring back to the embodiment shown in the drawings, and in particular FIG. 10 Once the annulus 62 and the area around the holes 60 have been voided of fluids, the pump can be moved up the hole and sealing material pumped down the production tubing annulus 62. This will equalise in both the tubing annulus and tubing ID at equal levels and form a perfect second barrier 70 to the reservoir.

[0040] Referring to FIG. 11, subsequently, at a suitable depth, a new set of perforations 80 are made and the residual mud in chambers 81 and 82 is allowed to drain into the sump 83 and 84. Preferably the next set of perforations is made at a depth where as many casing can be perforated as possible.

[0041] If the drained fluid rises above the pump 53, then the excess fluid can be pumped out the well via the umbilical. Finally, Referring to FIG. 12, sealing material 90 can be pumped into any of the voided chambers 91 or 92 and fill all the voided chambers 93 and 94 via the equalisation holes 95. The wellhead and multi casing string could then be safely removed, for example by abrasive jet cut off of the conductor below the mud line and safely recovered back to the vessel.

[0042] Referring to FIG. 13, in an other embodiment an electric pump 53 is lowered through the production tubing 30 of a cased well. A tailpipe seal assembly 102 is connected below the pump by a space out tube 103. In this embodiment, the umbilical does not have an through bore, and may simply comprise power cables 67 surrounded by a layer of armoured supporting cables 66, as shown in FIG. 9b.

[0043] Referring to FIG. 14, once the assembly is at the correct location anchors 104 on the tailpipe assembly 102 engage to secure the pump and tailpipe assembly. Perforation means 121 and 101 on the pump 53 and tailpipe assembly 102 are activated to create holes 110, 120 in the production tubing 30. The tailpipe assembly 102 includes upper and lower seals 106, 109 to isolate the area above and below the holes 110. The pump 53 then forces any well fluid 131 in the production tube above the pump, and the first annulus 132, through the space out tube 103 and check valve 108 to exit the tailpipe assembly and pass into the bottom of the well.

[0044] Referring to FIG. 15, cement or other sealing material is then pumped or poured into the production tubing 30 bore 131, the first tubing annulus 132, or both to form a seal above the production packer 45. The pump then pumps a predetermined volume of cement through the tailpipe assembly's check valve and thence beneath the tailpipe assembly 102. The cement is left to set to produce a plug of material at the bottom of the production tubing 30, the first annulus 131, and beneath the tailpipe to the well bottom 140. The a volume of cement sufficient to reach and seal the perforations 56 may be pumped into the bottom of the well.

[0045] Once this cement has set, a pressure test or a tag test may be carried out to confirm the cement's location and pressure holding capability. If such testing is not required, then the space out tube 103 and pump 53 may be pulled free of the tailpipe assembly and can be moved up the hole, as shown in FIG. 10. The top of the concrete seal may be typically at a depth of 10,000 feet. The pump is raised to between 500-1000 feet from the surface, and then the tube holding means 101 on the pump 53 make a series of holes 111 through the production tubing 30 and casing tubes 31, 32. Provided the fluid remaining the upper portions of annuli 145, 146 etc. are smaller than the voided volume of the lower part of annulus 141 and the production tube bore 140, this fluid will all drain into the lower part of annulus 141 and the production tube bore 140.

1. A method of abandoning a well, said well comprising at least two concentric conduits defining a main bore and at least one annular chamber there between, comprising the steps of:

- providing a perforation in one or more of the conduits,
- pumping out the fluid from the annular chamber and/or main bore to create a fluid-free void,
- inserting sealing material in the annular chamber and/or main bore to seal it/them.

2. A method according to claim 1 wherein sealing material is inserted into the bore of the innermost conduit to seal it.

3. A method according to claim 1 wherein a tube is introduced and the fluid pumped to the surface through the tube.

4. A method according to claim 1 wherein the fluid is pumped downwards into the well.

5. A method according to claim 1 wherein the sealing material is inserted in the annular chamber before the fluid from the annular chamber is pumped out.

6. A method according to claim 1 wherein perforations are formed in at least one conduit and the annular chamber or chambers are sealed at one level in the well, and then further perforations are formed in a greater number of conduits at a second higher level in the well.

7. A method according to claim 6 wherein after forming the further perforations in the greater number of conduits at the second higher level, the annular chambers between these conduits are sealed.

8. An apparatus for abandoning a well having at least two concentric conduits defining at least one annular chamber there between, the apparatus including a pump and a perforation forming device.

9. An apparatus according to claim 8 wherein there is also provided a valve unit capable of securing itself in an innermost conduit and including a check valve to permit the one-way flow of fluids.

10. An apparatus according to claim 8 wherein the pump and the valve unit are separable.

11. An apparatus according to claim 8 wherein there is provided a cable on which the pump may be lowered into the well.

12. An apparatus according to claim 8 wherein the perforation forming device is incorporated into the pump.

13. An apparatus according to claim 8 wherein the perforation forming device is incorporated into the valve unit.

14. An apparatus according to claim 8 wherein the cable includes a through bore.

15. (canceled)

* * * * *