

April 9, 1963

S. W. KOLK

3,084,368

HOLDER FOR SCRUBBING AND CLEANING DEVICES

Filed June 24, 1960

*Fig. 1*

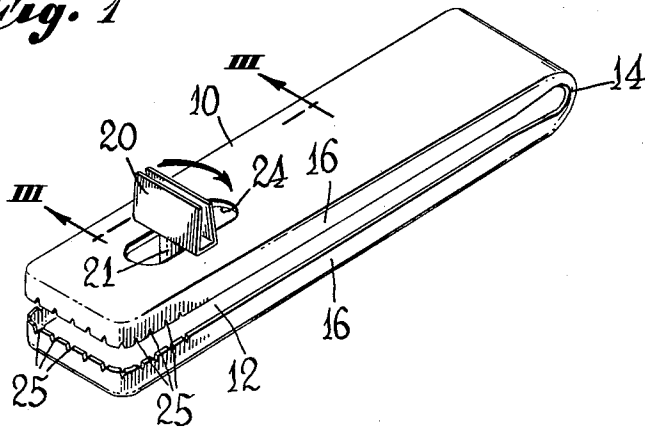

*Fig. 2*

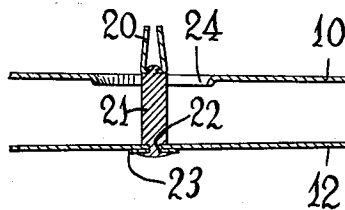
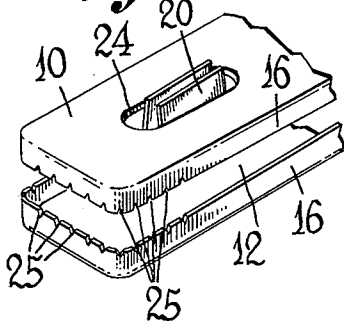

*Fig. 3*

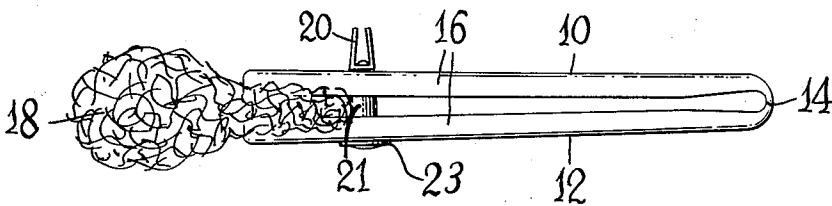

*Fig. 4*

INVENTOR.  
STEPHEN W. KOLK

BY

*Beau, Brooks, Buckley & Beau.*

1

3,084,368

**HOLDER FOR SCRUBBING AND  
CLEANING DEVICES**  
Stephen W. Kolk, 381 Old Falls Blvd.,  
North Tonawanda, N.Y.  
Filed June 24, 1960, Ser. No. 33,547  
1 Claim. (Cl. 15-209)

This invention relates to a holding handle for cleaning implements and more particularly to an improved handle or holder for such cleaning implements as scouring pads, sponges, rags and the like.

One object of the invention is to provide an improved holder for such cleaning implements as metallic wire scouring pads, sponges and the like which will enable the user to exert greater cleaning pressures to more thoroughly scour pots and pans or other objects being cleaned.

Another object of the invention is to provide a cleaning implement as aforesaid which will save the hands of the user from cuts and abrasions and from prolonged contact with the very strong and abrasive cleaners including powders used in the scouring of pots and pans, sinks, etc.

Another object of the invention is to provide a device as aforesaid which provides for very easy and quick attachment and detachment of the pads or the like being used therewith.

Still another object of the invention is to provide an implement as aforesaid which is extremely easy to use, simple in design, and inexpensive to the user.

Other objects and advantages of the invention will appear from the detailed description hereinbelow and the accompanying drawings wherein:

FIG. 1 is a perspective view of the cleaning implement holder of the invention;

FIG. 2 is a fragmentary view corresponding to FIG. 1 showing the device of the invention in the open position;

FIG. 3 is a sectional view taken substantially along the line III-III of FIG. 1; and

FIG. 4 is a side elevational view of the device of the invention which is shown holding a wire mesh scouring pad clamped therein.

As seen in the drawings, the holder-handle of the invention includes a pair of parallel arm portions 10 and 12 connected by means of a U-shaped spring end portion as indicated at 14. As illustrated, this construction may be accomplished by bending a single metal strip substantially upon itself. For increasing the rigidity and strength of the device, the arm members 10 and 12 are flanged as indicated at 16 around their free sides. The flange is cut back at the end portion 14 to facilitate opening and closing of the device.

As best seen in FIG. 4 the device of the invention is designed to hold a cleaning pad 18 or other devices such as scouring pads clamped between the jaw ends of the arms 10, 12. The arms 10, 12 are held in clamping position by a winged knob 20 which is pivotally mounted on the lower arm 12 by means of a post 21 having reduced end portions 22, 22, which are riveted to the arm 12 and the elongate knob 20 as shown. The swivelling action and strength of the joint between the post 21 and the arm 12 are improved by using a small washer 23 (FIG. 3) between the riveted end and the arm. The upper arm 10 is provided with a suitable slot 24 through which the winged knob 20 will pass when aligned longitudinally with

2

the arm 10 (FIG. 2). As best seen in FIG. 1, the winged knob will span the slot 24 when turned transversely thereto so as to hold the arms 10, 12 in pad gripping relation. In order to provide a more positive grip upon the article held between the jaws, notches as indicated at 25 may be cut into the opposed edges of the flanges 16 as shown. The post 21 is disposed adjacent but spaced from the front ends of the jaw portions of the device, whereby as shown in FIG. 4, the scouring pad 18 is held within the jaws which grip the pad along three sides thereof while the post 21 backs up the grip provided by the front edges of the jaws. Thus sidewise relative movement of the pad in the holder is restrained by two separate side grip effects, while fore-and-aft relative movement is restrained by the cooperating front edges of the jaws and the post 21. Because the pad devices to be held by the holder of the invention are of flexible nature, this improved gripping action renders the device much more effective and dependable in use.

Thus it will be appreciated that my invention provides a very simple and easily fabricated implement of great usefulness, and that although only one form of the invention has been illustrated and described herein the same has been done by way of illustration only and without thought of limitation. Having fully disclosed and completely described my invention together with its mode of operation, what I claim as new is:

A holder device for scrubbing and cleaning pads, comprising

an elongate body doubled upon itself to present substantially coextensive arms,

said arms being of channel shape in cross section providing a substantially flat web having flanges at either side, the side flanges being continuous throughout the length of said body but being of reduced height in that region wherein the body is doubled upon itself so as to permit the body to flex in such region,

each web also having a flange at its free end extending between and interconnecting the side flanges whereby the free end portions of said arms are relatively inflexible and the free edges of the flanges of the arms define pad-retaining jaws,

and means for releasably locking the relatively inflexible portions of said arms in jaw closing position, one of said arms having a longitudinally elongate opening in the relatively inflexible portion thereof, said means including an elongate wing rotatably carried by the other arm and projectible through such opening for rotation into bridging relation therewith to lock said arms as aforesaid.

## References Cited in the file of this patent

### UNITED STATES PATENTS

376,196	Hoffman	Jan. 10, 1888
832,317	Hinds	Oct. 2, 1906
911,466	Wilkins	Feb. 2, 1909
1,385,152	Schenck	July 19, 1921
1,631,791	Buckley	June 7, 1927
2,446,653	Kelly	Aug. 10, 1948
2,593,064	Silberman	Apr. 15, 1952

### FOREIGN PATENTS

3,512	Great Britain	1908
26,924	Great Britain	1902