

March 6, 1951

C. E. M. LEMBO  
ADJUSTABLE WAISTBAND

2,544,333

Filed Feb. 14, 1948

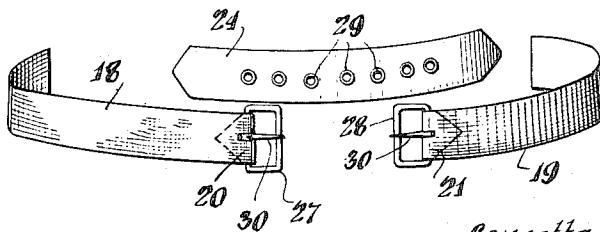
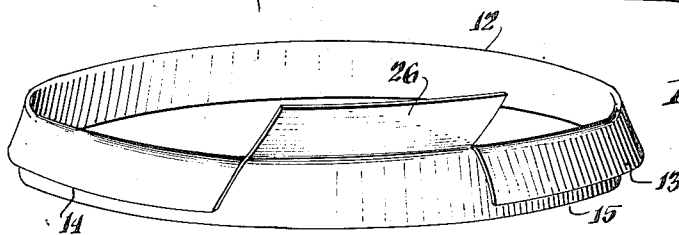
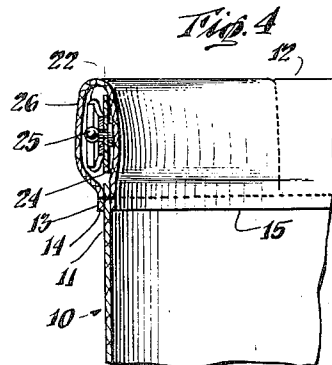
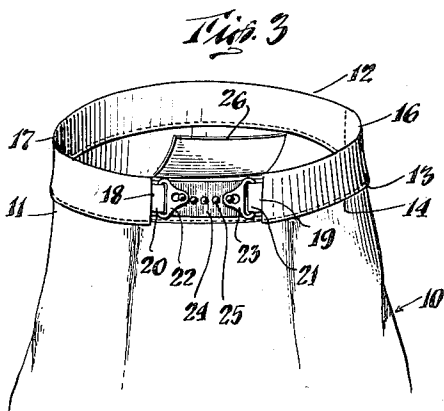
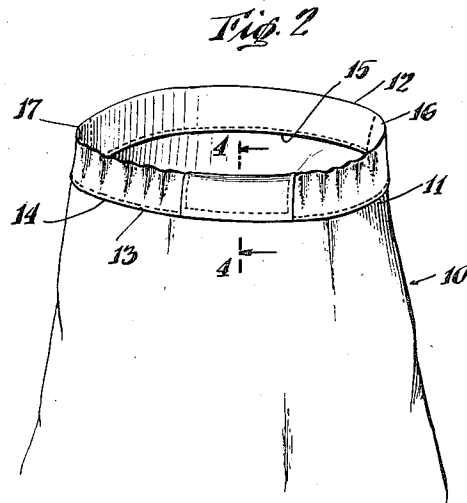
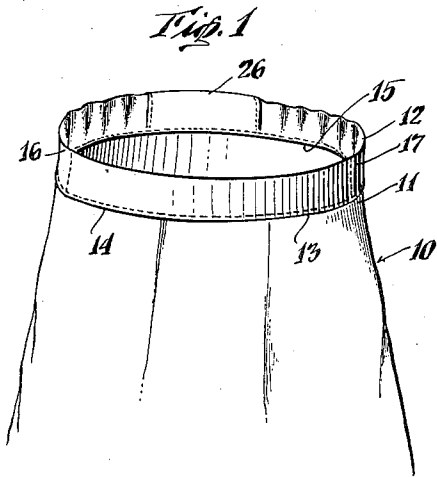

INVENTOR.  
Concetta E. M. Lembo

BY

Wick Padon and Seely

ATTORNEYS

# UNITED STATES PATENT OFFICE

2,544,333

## ADJUSTABLE WAISTBAND

Concetta E. M. Lembo, Brooklyn, N. Y.

Application February 14, 1948, Serial No. 8,432

3 Claims. (Cl. 2-221)

1

This invention relates to an adjustable waist band and, more particularly, to an adjustable elastic strap waist band for use in dresses, slacks, trunks and other types of wearing apparel.

In presently used types of clothing such as dresses and trousers, the waist hem portion of such clothing in time may stretch and not fit snugly against the girth of the wearer. Due to this variation, the waist appears somewhat ruffled and in time presents an untidy and unkempt appearance. Unless this untidiness is remedied, the clothing, because of its looseness, will permanently lose its original shape and appearance.

With the above disadvantages in view, it is an object of this invention to provide garments and other types of wearing apparel with an easily adjustable waist band.

Another object of this invention is to provide wearing apparel containing an easily attachable, economic, easily adjustable waist band adapted to assume the shape of the girth of the wearer without imparting an unpleasing appearance to the garment.

One other object of the present invention is to provide a tubular hem containing adjustable elastic and interconnecting members hidden from general view.

Other objects and advantages of this invention will become apparent from the following description taken in connection with the accompanying drawings, in which

Fig. 1 is a perspective front view of a dress embodying my invention;

Fig. 2 is a rear view of the dress showing some of the details thereof;

Fig. 3 is a view similar to Fig. 2 showing a portion of the embodiment exposed before finally covering same;

Fig. 4 is a detailed view taken on line 4-4 of Fig. 2;

Fig. 5 is a detailed, perspective view of another type of waist band used on wearing apparel in accordance with the present invention; and

Fig. 6 is an exploded, perspective, fragmental view of a portion of the embodiment shown in Fig. 5.

Referring now to the drawings in which like reference characters denote like parts throughout, a ladies' outer garment 10 such as that shown in Figs. 1 to 3, inclusive, is provided at its upper portion 11 with a tubular hem 12 forming the waist of the garment. It will be noted that the hem is preferably a flap of material folded over itself and stitched at its lower portion 13 where-

2

by the two marginal edges 14 and 15 of the flap meet and are sewed to the upper portion 11 of the garment 10, as shown in detail in Fig. 4, thus forming the tubular hem as heretofore indicated. Inside said hem and at the opposed lateral portions thereof, shown at 16 and 17, respectively, there are fitted elastic band members 18 and 19, respectively, extending toward the rear of the garment, as shown in Fig. 3. The free ends 20 and 21 of said band members are provided with eye buckles 22 and 23, respectively, which are fitted to the elastic bands in any suitable manner. It will be noted that these bands, with the eye buckles, extend from the back portion or rear of the garment to the lateral portions 16 and 17 so as to take up about two-thirds of the rear half of the garment.

Disposed at the rear portion of the tubular hem, as shown in Fig. 3, there is a strap member 24 provided with a plurality of flat-headed pins 25 fixed in any suitable manner to the strap in successive alignment whereby they can be engaged to the eye buckles at any interval, as shown in Fig. 3. After the proper adjustment has been made as to the diameter of the waist hem 12 and the elastic members, flap portion 26 of the hem is turned over the strap portion 24 and sewed to the upper portion 11 of the garment thereby rendering the waist band invisible.

In Figs. 5 and 6 there is shown a modification on my invention in which I have provided catch buckles 27 and 28 for the elastic bands 18 and 19 and in which the strap portion contains a plurality of eyelets 29 in consecutive alignment. Each of said buckles is provided with a shaft member 30 for engaging the eyelets depending upon the adjustment of the band, whereupon flap 26 is pressed over the strap portion of the band and sewed to the remaining portion of the garment.

In either modification, it is to be noted that said strap is not sewed to the hem in any way and that the buckles and strap portion are very thin and would not protrude or in any way show its outline in the hem when it is attached to the remaining portion of the garment or when the garment is worn.

It will be noted from the foregoing description, taken in connection with the accompanying drawings, that I have provided a relatively economic waist band which can be used on any type of wearing apparel and which can be easily removed or adjusted so as to conform with the girth of the wearer. Furthermore, when the elastic band has stretched, due to continuous

wear, and lost some of its elasticity, part of the band can be removed and the new free end of the band sewed to the hem thereby avoiding any shirring or unevenness to the waist of the garment. The device, according to my invention, is relatively thin and is not exposed to view nor does it protrude in any way so as to mar the appearance of the hem of the garment. The strap, as disclosed, may be padded and of any suitable material, such as leather or cloth and fits snugly against the back of the wearer without causing any discomfort from the pull of the elastic members in the hem.

It is understood that certain modifications as to form, use and arrangement of parts may be made without departing from the spirit and scope of the invention as claimed herein.

I claim:

1. Wearing apparel comprising a tubular waist hem, an elastic member fixed at one of its ends to the front portion and interior of said hem, another elastic member fixed at one of its ends to another portion of the interior of said hem and adjacent the fixed end of the other member, the free ends of the respective members extending toward the rear of the hem and being disposed in opposed relation to each other, an adjustable buckle member for each of the free ends of the elastic members, and an interconnecting strap disposed intermediate the buckle members containing a plurality of eyelets in alignment with each other for adjustable connection with the buckle members whereby the front portion of the hem is kept in a taut and smooth appearing condition.

2. An adjustable device for wearing apparel, comprising a tubular hem connected to and adapted to fit around the waist portion of the apparel, said hem being an extension of said apparel, a pair of opposed elastic members enclosed in said hem, each fixed at one respective

end to the frontal interior portion of the hem and having a free end, a buckle attached to said free end of each of said elastic members, and a strap member intermediate the buckles containing means for adjustable connection of the strap to the buckles, said members and buckles being movable and contained within the hem, and the strap connecting the buckles being adapted for relative adjustment of the buckles, said elastic members, upon stretching, being adapted to keep the frontal portion of the hem in a smooth, taut condition.

3. In wearing apparel of the character described, a tubular hem extending from the upper portion of the apparel so as to form the waist of said apparel, a pair of elastic band members in the hem, each of the members having one end fixed to opposite sides of the front portion of the hem and extending toward the rear portion thereof and having a free end, each of the free ends of said elastic members being provided with an eye buckle, and an intermediate and adjustable non-stretchable connecting strap member for said free ends disposed in the interior rear portion of the hem, having a plurality of successive flat-headed pin members projecting outwardly of the strap member to permit relative engagement of the buckles with said pin member.

CONCETTA E. M. LEMBO.

#### REFERENCES CITED

The following references are of record in the file of this patent:

#### UNITED STATES PATENTS

Number	Name	Date
549,666	Applebaum	Nov. 12, 1895
1,003,734	Goldberg	Sept. 19, 1911
2,237,022	Andrews	Apr. 1, 1941
2,393,392	Lyons	Jan. 22, 1946
2,439,339	Grisanti	Apr. 6, 1948