

(19) World Intellectual Property Organization
International Bureau



(43) International Publication Date
1 May 2003 (01.05.2003)

PCT

(10) International Publication Number
WO 03/034915 A1

- (51) International Patent Classification⁷: **A61B 5/00**
- (21) International Application Number: PCT/US02/34253
- (22) International Filing Date: 25 October 2002 (25.10.2002)
- (25) Filing Language: English
- (26) Publication Language: English
- (30) Priority Data:
60/335,694 25 October 2001 (25.10.2001) US
- (71) Applicant (for all designated States except US): **ALLEGIANCE CORPORATION** [US/US]; 1430 Waukegan Road, McGaw Park, IL 60085-6787 (US).
- (72) Inventor; and
- (75) Inventor/Applicant (for US only): **KRUEGER, John, A.** [US/US]; 2936 N. 79th Street, Milwaukee, WI 53222 (US).
- (74) Agent: **ROZYCKI, Andrew, G.**; 7000 Cardinal Place, Dublin, OH 43017 (US).

- (81) Designated States (national): AE, AG, AL, AM, AT, AU, AZ, BA, BB, BG, BR, BY, BZ, CA, CH, CN, CO, CR, CU, CZ, DE, DK, DM, DZ, EC, EE, ES, FI, GB, GD, GE, GH, GM, HR, HU, ID, IL, IN, IS, JP, KE, KG, KP, KR, KZ, LC, LK, LR, LS, LT, LU, LV, MA, MD, MG, MK, MN, MW, MX, MZ, NO, NZ, OM, PH, PL, PT, RO, RU, SD, SE, SG, SI, SK, SL, TJ, TM, TN, TR, TT, TZ, UA, UG, US, UZ, VN, YU, ZA, ZM, ZW.
- (84) Designated States (regional): ARIPO patent (GH, GM, KE, LS, MW, MZ, SD, SL, SZ, TZ, UG, ZM, ZW), Eurasian patent (AM, AZ, BY, KG, KZ, MD, RU, TJ, TM), European patent (AT, BE, BG, CH, CY, CZ, DE, DK, EE, ES, FI, FR, GB, GR, IE, IT, LU, MC, NL, PT, SE, SK, TR), OAPI patent (BF, BJ, CF, CG, CI, CM, GA, GN, GQ, GW, ML, MR, NE, SN, TD, TG).

Published:

- with international search report
- before the expiration of the time limit for amending the claims and to be republished in the event of receipt of amendments

[Continued on next page]

(54) Title: BONE BIOPSY INSTRUMENT HAVING IMPROVED SAMPLE RETENTION

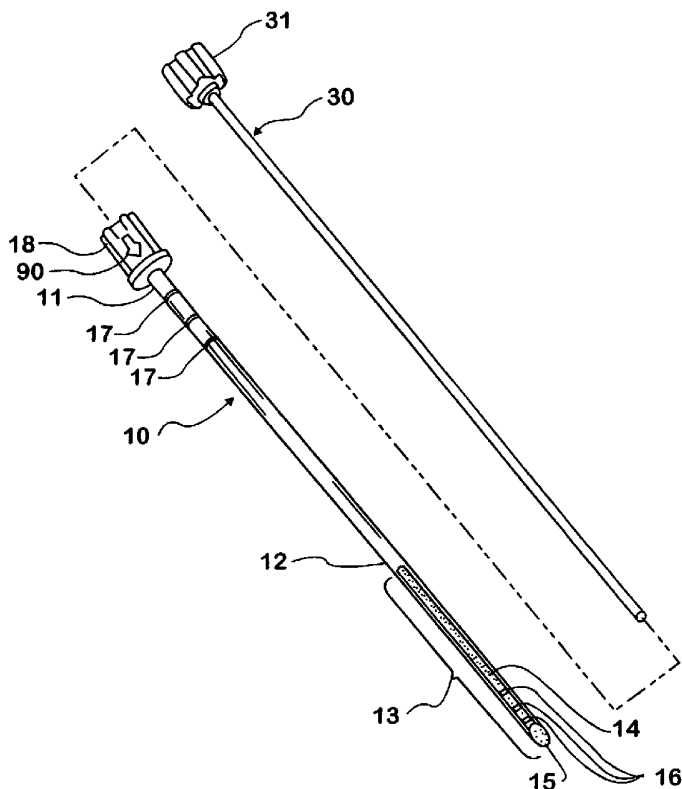

(57) Abstract: The invention disclosed herein relates to a sampling cannula (10) for use in bone marrow biopsy procedures having structural features which facilitate sample retention within the device. In particular, the sampling cannula (10) comprises an open trough-like portion (13), wherein the trough-like portion (13) comprises at least one wall opening (16) located proximal to the distal end in combination with an interior surface (14) comprising a friction-enhancing surface texture (adapted to facilitate sample retention). The invention further provides for a bone marrow biopsy system comprising an outer cannula having a sharpened distal tip (15), a sampling cannula having a distal trough portion (13) in which the interior surface of the sampling cannula (14) is exposed, at least one wall opening located within the trough portion (13) located proximal to the distal tip of the sampling cannula, a friction-enhancing surface texture on at least a portion of the interior surface of the trough portion, wherein the sampling cannula is adapted to be inserted into an outer cannula (20), and to server a sample from the sampling site by rotational motion of the sampling cannula, and a stylet (30) structured to be removably inserted into the outer cannula (20). The bone biopsy system can further include and ejector rod for expelling the retained sample from the sampling



WO 03/034915 A1
cannula.



For two-letter codes and other abbreviations, refer to the "Guidance Notes on Codes and Abbreviations" appearing at the beginning of each regular issue of the PCT Gazette.

BONE BIOPSY INSTRUMENT HAVING IMPROVED SAMPLE RETENTION**Inventor: John Krueger****RELATED APPLICATION DATA**

This application is based on U.S. Provisional Application No. 60/335,694 filed on October 25, 2001, and this application is also a continuation-in-part of U.S. patent application Serial No. 09/799,143 filed March 5, 2001, now pending, which is a divisional of U.S. patent application Serial No. 09/522,444 filed April 18, 2000, now U.S. Patent No. 6,443,910 issued on September 3, 2002.

FIELD OF THE INVENTION

The invention relates to the field of medical devices for use in biopsy procedures. In particular, the invention pertains to a bone marrow biopsy device and method for obtaining
5 bone marrow samples therewith.

BACKGROUND OF THE INVENTION

Biopsy samples from bone tissue are typically collected from a sampling site in a patient by the use of bone biopsy devices. Typical bone biopsy devices include a hollow
10 cannula which surrounds a stylet. The stylet includes a sharp distal tip which extends distally beyond the tip of the hollow cannula when the stylet is secured within the cannula. The combined cannula and stylet is used to penetrate through the cortex or outer layer of bone so as to sample the softer tissue or marrow within the bone. Once the cannula and stylet have penetrated into the bone, the stylet is removed and the cannula further advanced into the bone
15 to capture a marrow sample.

The architecture of the tissue sample is important in several respects. Initially, the size of the sample is important, with larger sample sizes representing better samples for subsequent testing to be performed on the tissue. The larger the cannula and stylet which is used, however, the more pain is generated at the penetration site for the patient. Another
5 aspect of sampling is minimizing damage to the sample, such as compressive forces, during sampling and removal.

A variety of bone biopsy devices have been proposed to improve the biopsy sampling procedure. Andelin et al. U.S. Patent No. 6,110,128, Guirtino et al. U.S. Patent No. 5,615,690 and Mittermeier et al. U.S. Patent No. 6,063,037 describe a biopsy devices with
10 structural features designed to enhance sample retention. Other bone biopsy devices have been developed which aid in the preservation of sample integrity by virtue of their structure. One such device is described in Krueger et al., U.S. Patent No. 6, 443,910, which includes a sampling cannula having a “cutting finger” on the distal portion of the cannula.

Difficulty has been encountered in the art in the balancing between the structural
15 requirements of bone biopsy devices and desirable sampling attributes. Providing bone biopsy devices that consistently sample without damaging forces being exerted upon the sample has proven challenging. Furthermore, accommodating patient comfort by reducing the need for multiple site sampling has presented another challenge. Preserving the architecture of the sample during its obtaining and removal presents yet another factor to be
20 balanced in bone biopsy devices.

There is a need in the field of medical bone biopsy devices for biopsy devices which facilitate the retention of the obtained sample while at the same time preserving the structural integrity of the sample and reducing the amount of trauma to the patient.

SUMMARY OF THE INVENTION

The invention provides for a bone marrow biopsy device, specifically a sampling cannula, having structural features which improve the ability to sever and retain a relatively large marrow sample. It has been discovered that a sampling cannula can be constructed
5 which affords the benefits of obtaining a relatively long core of bone tissue sample and enhancing the retention of the sample within the cannula while at the same time preserving the structural integrity of the sample. In particular, it has been discovered that a bone marrow sampling cannula having the advantages of an open trough-like distal structure can comprise both a friction-enhancing interior surface texture and wall openings which facilitate sample
10 retention without substantially damaging the biological "architecture" of the core sample.

The invention provides for a sampling cannula for use in bone marrow biopsy system comprising:

- a sampling cannula having a distal trough portion in which the interior surface of said sampling cannula is exposed;
- 15 at least one wall opening located within said trough portion located proximal to the distal tip of said sampling cannula;
- a friction-enhancing surface texture on at least a portion of the interior surface of said trough portion;
- wherein said device is adapted to be inserted into an outer cannula and to sever a
20 sample from the sampling site by rotational motion of the sampling cannula.

In a preferred embodiment, the trough portion comprises a plurality of wall openings. In another preferred embodiment, each wall opening comprise a substantially rectangular shape.

The invention further provides for a bone marrow biopsy system comprising:

an outer cannula having a sharpened distal tip;

a sampling cannula having a distal trough portion in which the interior surface of said sampling cannula is exposed;

at least one wall opening located within said trough portion located proximal to
5 the distal tip of said sampling cannula;

a friction-enhancing surface texture on at least a portion of the interior surface of said trough portion;

wherein said device is adapted to be inserted into an outer cannula and to sever a sample from the sampling site by rotational motion of the sampling cannula; and

10 a stylet structured to be removably inserted into the outer cannula.

In a preferred embodiment, the distal tip of the trough portion of the sampling cannula resides within the outer cannula such that the trough portion distal tip terminates proximal to the distal tip of the outer cannula. The bone marrow biopsy system can further comprise an ejector rod.

15

BRIEF DESCRIPTION OF THE DRAWINGS

Figure 1 is an overall perspective view of the sampling cannula and an ejector rod according to one embodiment of the invention.

Figure 2 is a side view of the sampling cannula according to one embodiment of the
20 invention.

Figure 3 is an enlarged frontal view of the distal trough portion of the sampling cannula according to one embodiment of the invention.

Figure 4 is a disassembled view of a bone marrow biopsy system comprising a sampling cannula, outer cannula and stylet according to one embodiment of the invention.

Figure 5 is an illustration of a sequence of biopsy steps with a bone biopsy system comprising the sampling cannula according to one embodiment of the invention.

DETAILED DESCRIPTION OF THE DRAWINGS

5 As used herein, the terms “trough” and “trough-like” as used to describe a structural feature of the device of the invention, are meant to describe a cannula structure having an open segment at which the interior surface of the cannula is exposed through an elongated, generally linear open region on the opposite side from an intact portion.

The term “substantially rectangular” as used to refer to a wall opening of the sampling
10 cannula is intended to encompass variations of length, width, and overall shape provided there is an overall longitudinal dimension of such opening.

Referring to Figures 1, 2 and 3, the sampling cannula of the invention generally comprises a cannula body 10 structure having a longitudinal body with proximal and distal portions 11 and 12 respectively. The distal portion 12 of the sampling cannula comprises a
15 trough portion 13 in which the cannula 10 structure is circumferentially incomplete, creating an exposed interior surface 14 of the sampling cannula viewable through an elongated open portion on the opposite side from an intact portion. The trough portion 13 originates at a location proximal to the distal tip and extends to terminate at the distal tip 15 of the cannula body 10. The sampling cannula, by way of the trough portion 13, is adapted to rotate about
20 its longitudinal axis in order to sever a sample from the sampling site when positioned within an outer cannula 20 (see Figure 4) which is structured to “core” into the bone tissue. The sampling cannula can be rotated 360° or less as needed to sever the sample from surrounding tissue. With the sample residing within the trough portion 13, the sampling cannula with the sample therein is withdrawn from the site. The wall opening(s) and friction-enhancing

interior surface of the trough portion 13 facilitate retention of the sample. Accordingly, the amount of compressive force exerted upon the sample is significantly reduced during separation of the sample from surrounding tissue) and retaining the sample. Thus, damage to the sample and altering its in situ "architecture" as a result of compression is reduced or
5 avoided.

The dimensions of the cannula 10 and trough 13 can vary according to the nature of the sampling site and/or desired sample size. The cannula cross-sectional diameter of the device can vary provided the device can effectively obtain and retain a sample within. For example, 8 gauge, 11 gauge or 13 gauge sizes can be used. For a given combination of
10 dimensions and materials to be used, the hoop strength of the trough portion, i.e., structural integrity of the intact cross-sectional circumference of the intact portion of the cannula body, must be maintained to an extent sufficient to withstand the physical forces exerted upon it during the penetration and sampling stages of the bone marrow biopsy procedure.

The length of the trough portion 13 can vary according to the sample size desired
15 provided the structural integrity of the device is not adversely compromised when sampling forces are exerted upon it. In a preferred embodiment, the trough portion 13 can have a length of up to about 4 cm. Most preferably, the length of the trough portion 13 is about 3 cm. A relatively long trough length is preferred so as to permit a lengthier core sample to be obtained from a patient. Such lengthy sample sizes allow the user to advantageously observe
20 the pathological history of the sampled bone.

The distal tip 15 of the trough portion 13 of the sampling cannula 10 can be shaped to facilitate penetration and cutting of the bone tissue. In one embodiment and as shown in Figure 2, the tip is angled relative to the longitudinal axis of the cannula and comprises a distal cutting edge which is beveled or shaped into a rounded curve as shown in Figures 1 and

3. In a preferred embodiment, the overall length of the sampling cannula is such that when positioned within the outer cannula, the distal cutting tip 15 of the sampling cannula resides within the outer cannula proximal to the distal tip of the outer cannula.

The dimensions of the trough portion 13 in terms of cross-sectional intact
5 circumference of the cannula body 10 can vary provided sampling by rotational motion thereof can effectively sever and retain a sample therein without adversely compromising the structural integrity of the trough portion. In addition to trough portion length, the rigidity of the cannula body material, thickness of the cannula wall, diameter (gauge) of the cannula all must be balanced together with the amount of the intact portion of the cannula body in the
10 trough. The amount of intact cross-sectional circumference of the trough portion can range from about 65% to about 85% of a complete cannula circumference. The amount of the intact portion of the trough will vary in cooperation with the diameter or size of the cannula used. Accordingly, the larger the diameter (or lower the gauge) of the cannula, the greater the amount of intact portion required. For example, if a 13 gauge cannula is used for the device,
15 the amount of intact circumferential portion can be about 65%, whereas if an 8 gauge cannula is used, the amount of intact circumferential portion can be about 85%.

During sampling, opening(s) 16 through the wall of the trough portion function to permit a slight encroachment of the tissue therein, thereby physically “interlocking” or engaging a portion of the sample within and providing resistance to longitudinal migration of
20 the sample. The number, size, shape and arrangement of wall opening(s) 16 in the trough portion 13 can vary provided the opening(s) 16 enhance the retention of the sample within the trough. In accordance with the invention, at least one opening 16 is present through the wall of the trough portion 13. In a preferred embodiment, a plurality of wall openings 16 in the

trough portion 13 are present. In one embodiment shown in the Figures, three openings can be present.

The shape of the wall opening(s) 16 can vary as well. Opening shapes which can be used include, but are not limited to, rectangular, square, ovular, circular, triangular, and the
5 like. A preferred opening shape is substantially rectangular opening wherein the longer dimension is perpendicular to the longitudinal axis of the sampling cannula body as shown in Figure 3, illustrating a plurality of substantially rectangular openings.

The size of opening 16, i.e., opening dimensions, can vary provided it is large enough to permit encroachment of the collected tissue sample while small enough to avoid
10 compromising the structural integrity of the trough portion. When a substantially rectangular opening shape is used, the opening(s) can have a length (relative to the longitudinal axis of the trough portion) ranging from about 0.25 mm to about 0.75 mm. In one embodiment, a rectangular opening has a length of about 0.50 mm. The width (relative to the longitudinal axis of the trough portion) of a rectangular opening can vary as well. The depth (inward
15 direction from a side view relative to the bottom-most portion of the base of the trough) can vary and is typically in the range from about 0.1 mm to about 0.3 mm.

When a plurality of openings are used, the trough portion of the device can comprise combinations of opening shapes having the different sizes, shapes, or both. According to the invention and when a plurality of openings are used, the arrangement of openings 16 in the
20 trough portion 13 can vary as well. Suitable opening arrangements include, but are not limited to, linear alignment along the longitudinal axis of the cannula (as shown in the Figures) and staggered within the trough portion. In a preferred embodiment, a plurality of openings 16 are located within a distance from about 1 cm to about 1.5 cm from the distal end
15 of the trough portion 13.

Referring again to Figure 3 and in another embodiment of the invention, the interior surface 14 of the trough portion 13 can further comprise a friction-enhancing surface texture that is adapted to facilitate sample retention. Surface textures which can be used include, but are not limited to, roughened surface textures. When roughened surface texture is used, the surface is roughened to the extent sufficient to increase coefficient of friction of surface to retain sample while at the same time not affording significant resistance to the movement of the tissue into the trough. Various techniques readily available to those skilled in the medical device arts can be used to roughen the interior surface of the trough portion, such as sandblasting and chemical etching. Some or all of the interior surface of the trough portion of the device can be textured.

In a further embodiment, the exterior surface of the proximal portion 11 of the sampling cannula can comprise viewable markings or indicia 17. Markings 17 which can be used include, but are not limited to, orientation indicia, depth markings, numbers, symbols, letters, and the like. Such markings can be printed, etched or embossed. In one particular embodiment and as shown in Figures 1, 2 and 4, the proximal portion 11 of the device comprises external depth markings 17. The markings are viewable upon displacement of the sampling cannula in the proximal direction while the remaining sampling cannula resides within the outer cannula.

Thus, in use, the distance of displacement of the sampling cannula relative to the outer cannula after the outer cannula has been advanced into the sampling site should substantially correspond to the length of the sample which will be obtained when the sampling cannula is likewise advanced and rotated to sever the sample.

The proximal portion 11 of the sampling cannula of the invention can further comprise a hub 18 coupled thereto in order to facilitate grip and handling by the user during

operation of device, e.g., forward pressure for insertion in longitudinal direction and rotational motion for severing sample from site. The hub 18 can be attached to the cannula body 10 using a variety of conventional techniques, such as UV-curable adhesive bonding. The exterior surface of the hub 18 can comprise a surface texture, treatment or geometry to further facilitate grip and handling. The hub 18 can also further comprise markings or indicia, such as an orientation marking 90 (see Figures 1 and 4) indicating the position or alignment of the opening of the trough portion of the sampling cannula.

According to the invention, the sampling cannula can be used as a component of a bone biopsy assembly such as that described by Krueger et al., US. Patent No. 6,443,910, the entire text of which is incorporated herein by reference. In general, bone biopsy assemblies that can be used which include the sampling cannula of the invention include those such as that shown in Figure 4, which comprises an outer cannula 20 secured or affixed to a handle 22, and a stylet 21 structured to be removably inserted into the outer cannula 20 and which, when inserted into the outer cannula 20 is used to penetrate the cortex of the bone. The outer cannula 20 can be a component of an assembly having a handle 22 secured to the proximal region thereof, and can further comprise a cap 40 which can be positioned over the proximal end of the outer cannula 20 and handle 22 to prevent proximal movement of the stylet 21 during the penetration stage of the procedure.

Accordingly, the handle 22 is fixed to the outer cannula 20, and the stylet 21 is positioned within the outer cannula 20 and the cap 40 secured onto the handle 22 and covering the proximal end of the stylet 30. The assembled system is then inserted into the bone as illustrated in Figure 5. When the distal portion of the outer cannula 20 is positioned near the sampling site, the cap 40 is removed and the stylet 21 is withdrawn from the outer cannula 20. The outer cannula 20 is further advanced into the bone to "core" a sample in the

longitudinal direction. Subsequently, the sampling cannula of the invention can be inserted into the outer cannula 20 until the distal end of the sampling cannula is positioned just proximal to the distal tip of the outer cannula 20, and then rotated to circumscribe and thus sever the sample from the surrounding tissue. The sampling cannula with the core sample 60
5 residing within the trough portion 13 is subsequently withdrawn.

The bone biopsy system can further comprise an ejector rod 30 adapted or structured to be inserted within the sampling cannula in order to expel the core sample from the sampling cannula. The ejector rod 30 can comprise an ejector rod hub 31. The ejector rod can be composed of any rigid or semi-rigid material suitable for such use, including
10 polymeric and metallic materials. Preferably, the ejector rod 30 is composed of plastic.

The sampling cannula 10, outer cannula 20 and stylet 21 can be composed of any material which is sterilizable and suitable for use in medical devices and which can withstand the physical forces exerted upon it during bone biopsy techniques. Suitable materials include metals and metallic alloys, such as stainless steel and titanium. The hub, handle and ejector
15 rod components can be composed of polymeric materials or plastic, and made according to conventional molding techniques readily available to those in the medical device field.

Process of Making the Device:

The following is one example of a manufacturing technique which can be used to make the device in accordance with one embodiment of the invention.

20 Raw stainless steel tubing is cut to the desired length using a disc cutter to prepare a cannula. A bevel or curved tip is created in one end of the cannula using a grinder at the desired angle relative to the longitudinal axis of the cannula. One or more of the cannulas are fixed onto a plate. A wheel grinder is applied to the uppermost surface of each cannula and applied to the desired depth to remove the uppermost surface of the cannula as well as the

desired length of the cannula to be removed. The grinder thus creates a trough structure and exposes the interior of the cannula. Next, a grinding machine is applied to the underside intact portion of the cannula using one or more discs sized and spaced to create the desired dimensions of the openings in the trough portion. More than one opening can be created
5 simultaneously. Electropolishing techniques using electrolytic acid solution can be used to remove burrs and particulate matter from the surface. The exposed interior of the trough portion of the cannula can be sandblasted to create the roughened surface texture. Additionally, the exterior surface of the proximal end of the cannula can be sandblasted as well to facilitate the bonding of a hub thereto. To attach a hub to the proximal end of the
10 cannula, the hub can be positioned on the proximal end and bonding material can be injected into the space between.

Plastic components, for example a sampling cannula hub 18, can be formed in accordance with conventional molding equipment and methods readily available in the art.

Biopsy Procedure using the Device:

15 Referring to Figure 4, the following is an example of a bone marrow biopsy procedure using the device according to one embodiment of the invention.

The patient is prepared in accordance with standard surgical preparation techniques for bone biopsy procedures. As seen in Step #1, a bone biopsy assembly including an outer cannula 20 with a removable stylet 21 within and coupled to a handle 22 is inserted into the
20 patient penetrating the skin and cortical layer of the bone to be sampled. Once the cortex of the bone has been penetrated by the distal end of the outer cannula 20, the stylet 21 is then removed as depicted in Step #2. As shown in Step #3, once the stylet has been removed, the outer cannula 20 is further advanced into the sampling site to create a "core" sample within the outer cannula. At this point, the device of the invention is inserted into the interior of the

outer cannula to the desired depth as indicated by observing the proximal portion of the device outside the patient's body as depicted in Step #4. Once the device of the invention, specifically the trough portion of the device, has been advanced to the desired extent, the user rotates the hub as shown in Step #5 to rotate the trough portion of the device to sever the sample from the site. The device of the invention is then removed from the bone with the sample contained within the trough. Once outside of the patient's body, the ejector rod 30 can be inserted into the device in a longitudinal direction to expel the sample from the device as shown in Step #6. Alternatively and as shown in Steps # 4 and 5, the ejector rod 30 can accompany the device of the invention throughout the insertion and removal of the device wherein the rod does not penetrate beyond the cortex.

Industrial Applicability:

The invention is useful in the medical field under circumstances where sampling a patient's bone tissue is needed. The device affords the practitioner or user the advantages of maintaining the architectural integrity of the sample as well as improved sample retention upon removal.

The invention has been described with reference to various and specific embodiments and techniques. It will be understood, however, that reasonable modifications and variations of such embodiments and techniques can be made without departing from the spirit or scope of the invention defined by the claims set forth below.

20

CLAIMS

What is claimed is:

1. A sampling cannula for use in bone marrow biopsy system comprising:
a sampling cannula having a distal trough portion in which the interior surface of said
5 sampling cannula is exposed;
at least one wall opening located within said trough portion located proximal to the
distal tip of said cannula;
a friction-enhancing surface texture on at least a portion of the interior surface of said
trough portion;
10 wherein said device is adapted to be inserted into an outer cannula and to sever a
sample from the sampling site by rotational motion of the sampling cannula.
2. The sampling cannula according to claim 1 wherein the trough portion comprises a
plurality of wall openings.
3. The sampling cannula according to claim 2 wherein the trough portion comprises
15 three wall openings.
4. The sampling cannula according to claim 2 wherein the wall openings have a
generally rectangular shape, the longer sides of the rectangle being substantially
perpendicular to the longitudinal axis of the sampling cannula.
5. The sampling cannula according to claim 1 further comprising markings located on
20 the exterior surface of the proximal portion of the sampling cannula.
6. The sampling cannula according to claim 5 wherein said markings comprise sampling
depth indicia.
7. The sampling cannula according to claim 1 wherein the proximal portion of the
sampling cannula further comprises a hub.

8. The sampling cannula according to claim 7 wherein the sampling cannula hub further comprises orientation indicia relative to the trough portion.
9. A bone marrow biopsy system comprising:
an outer cannula having a sharpened distal tip;
5 a sampling cannula having a distal trough portion in which the interior surface of said sampling cannula is exposed;
at least one wall opening located within said trough portion located proximal to the distal tip of said sampling cannula;
a friction-enhancing surface texture on at least a portion of the interior surface of
10 said trough portion;
wherein said sampling cannula is adapted to be inserted into an outer cannula and to sever a sample from the sampling site by rotational motion of the sampling cannula;
and
a stylet structured to be removably inserted into said outer cannula.
- 15 10. The bone marrow biopsy system according to claim 9 wherein the distal tip of the trough portion of the sampling cannula resides within the outer cannula such that the trough portion distal tip terminates proximal to the distal tip of the outer cannula.
11. The bone marrow biopsy system according to claim 9 further comprising an ejector rod.
- 20 12. The bone marrow biopsy system according to claim 11 wherein said ejector rod is composed of plastic.
13. The bone marrow biopsy system according to claim 9 wherein the sampling cannula trough portion comprises a plurality of wall openings.

14. The bone marrow biopsy system according to claim 13 wherein the sampling cannula trough portion comprises three wall openings.
15. The bone marrow biopsy system according to claim 13 wherein the sampling cannula wall openings have a generally rectangular shape, the longer sides of the rectangle
5 being substantially perpendicular to the longitudinal axis of the sampling cannula.
16. The bone marrow biopsy system according to claim 9 wherein the sampling cannula further comprises markings located on the exterior surface of the proximal portion of the sampling cannula.
17. The bone marrow biopsy system according to claim 16 wherein the sampling cannula
10 markings comprise sampling depth indicia that are viewable upon displacement of the sampling cannula in the proximal direction relative to the outer cannula.
18. The bone marrow biopsy system according to claim 9 wherein the proximal portion of said sampling cannula further comprises a hub.
19. The bone marrow system according to claim 18 wherein the sampling cannula hub
15 further comprises orientation indicia relative to the trough portion.
20. A bone marrow biopsy system comprising:
a sampling cannula having a distal trough portion in which the interior surface of said sampling cannula is exposed;
at least one wall opening located within said trough portion located proximal to
20 the distal tip of said sampling cannula;
a friction-enhancing surface texture on at least a portion of the interior surface of said trough portion;
wherein said sampling cannula is adapted to sever a sample from the sampling site by rotational motion of the sampling cannula; and

an ejector rod structured for removable insertion into said sampling cannula to expel a sample residing therein.

21. The bone marrow biopsy system according to claim 20 wherein the proximal portion of said sampling cannula comprises sampling depth indicia that are viewable upon displacement of the sampling cannula in the proximal direction relative to the outer cannula.
22. The bone marrow biopsy system according to claim 20 wherein the proximal end of said sampling cannula comprises a hub.
23. The bone marrow biopsy system according to claim 22 wherein the hub further comprises orientation indicia relative to the trough portion.

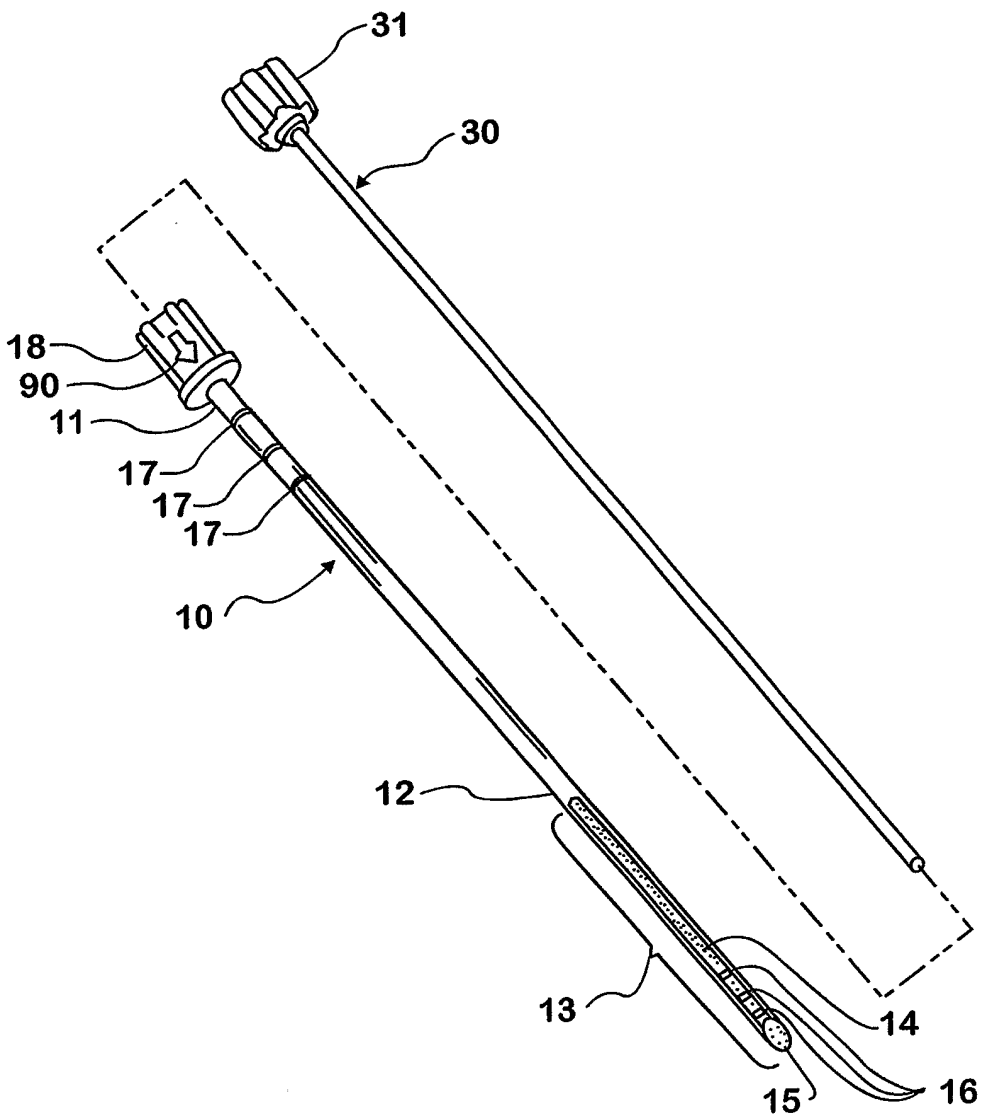

FIG. 1

┌

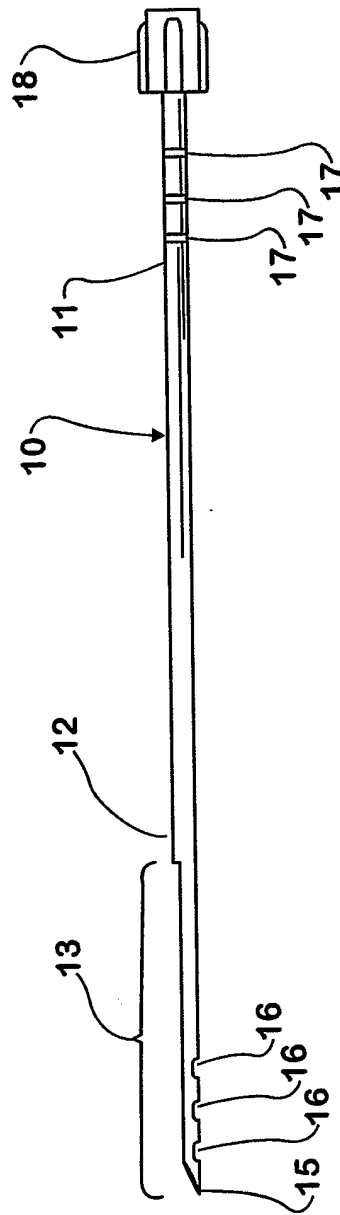

FIG. 2

└

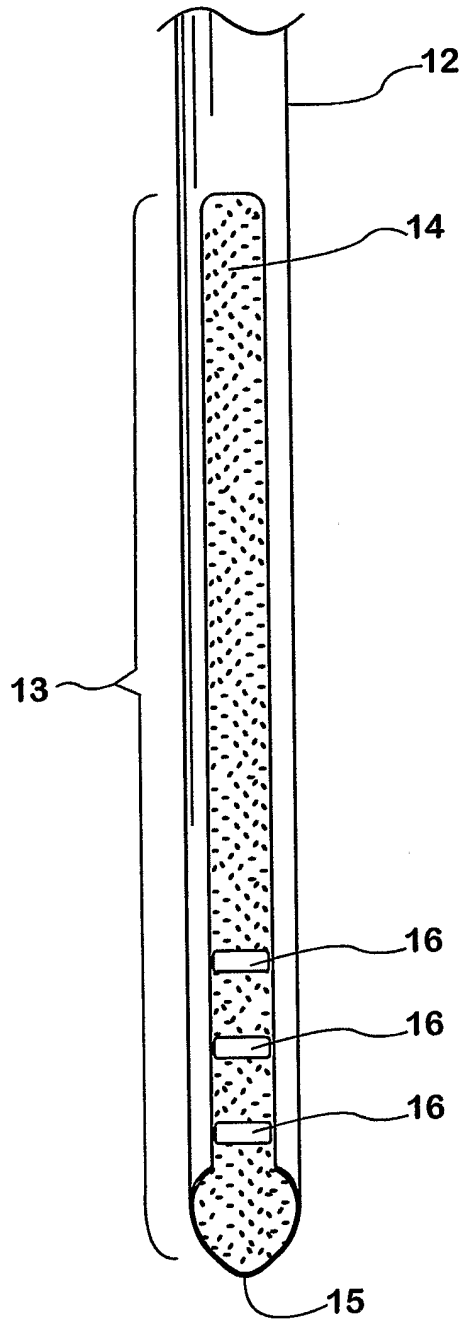

FIG. 3

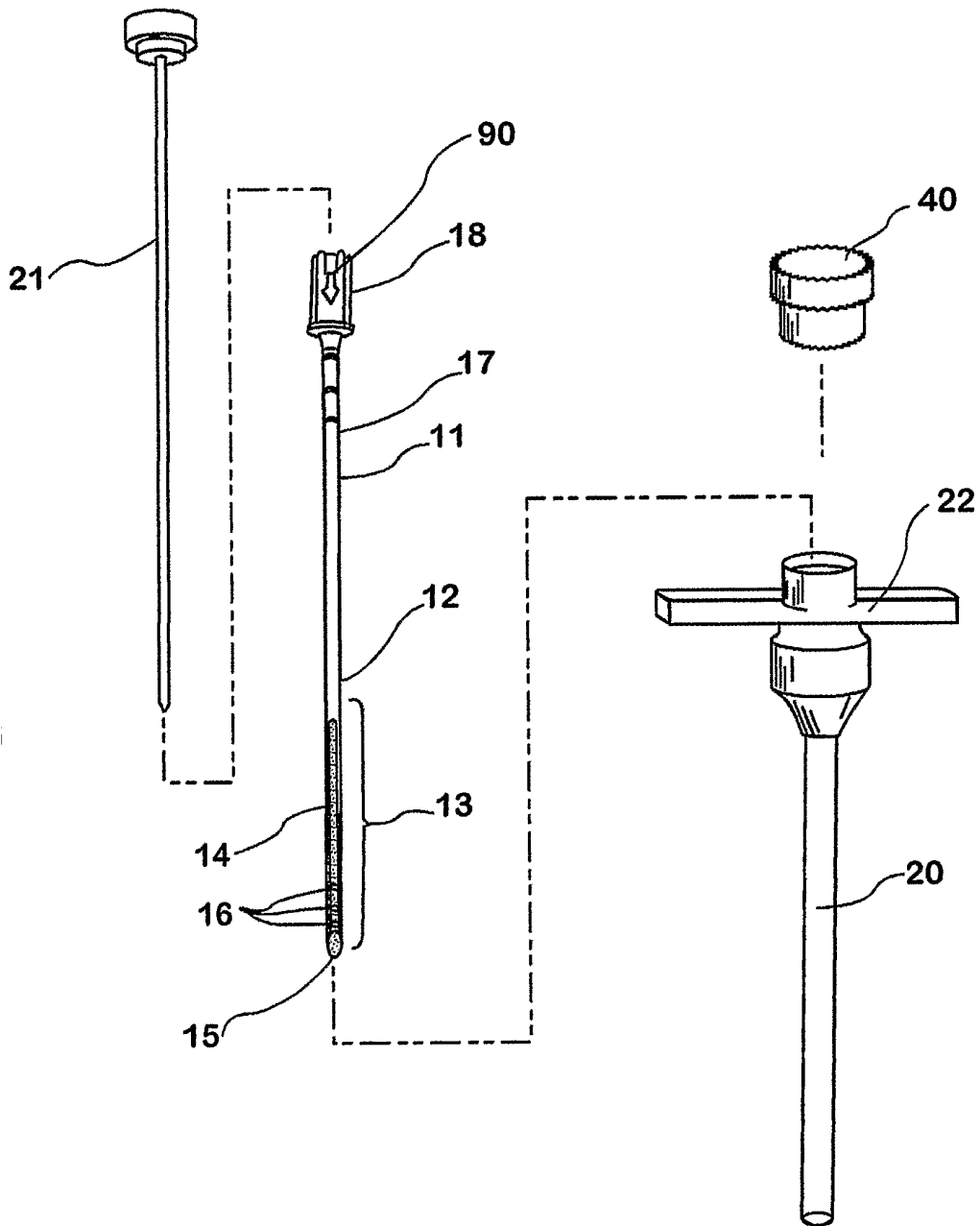

FIG. 4

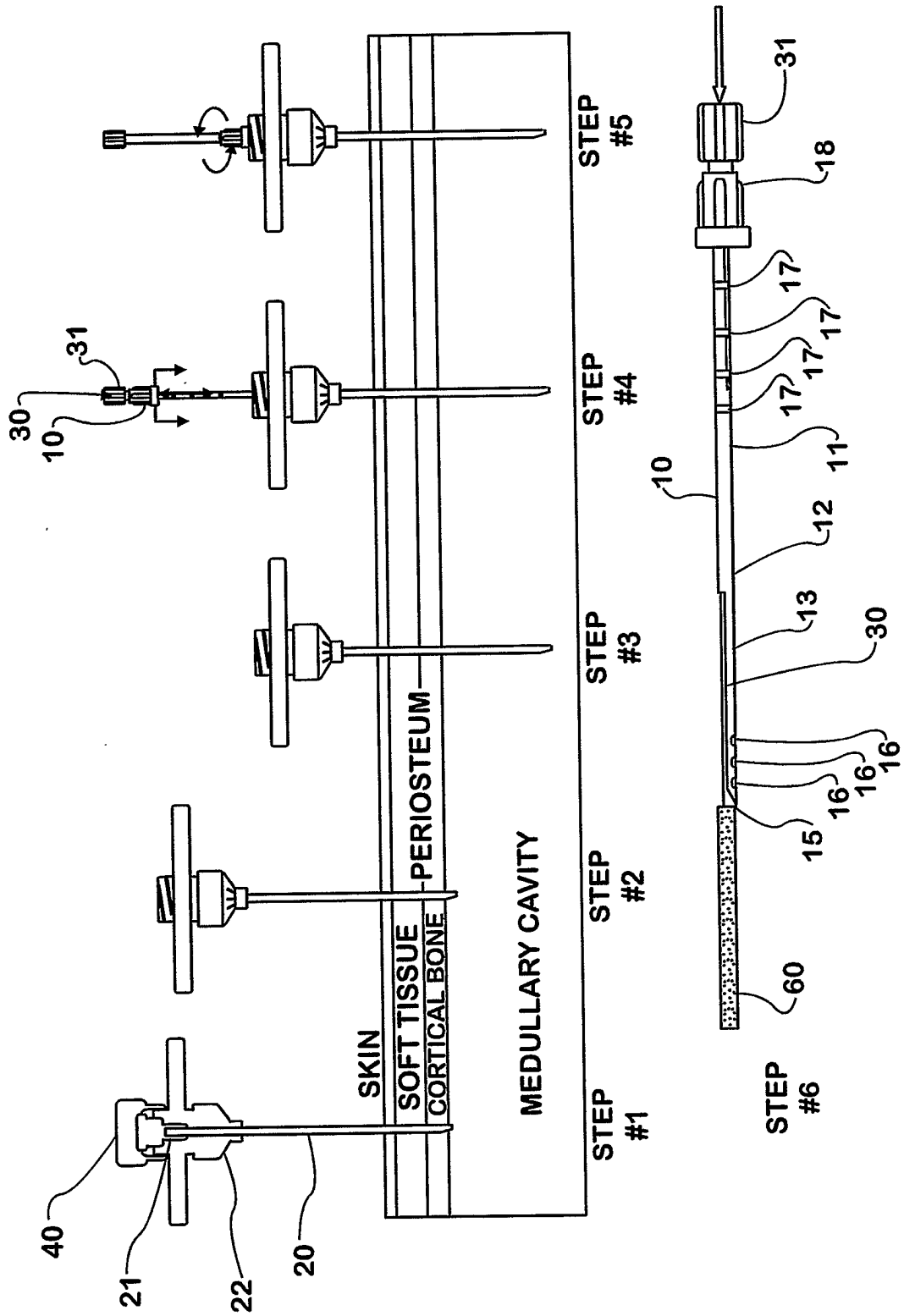

FIG. 5

INTERNATIONAL SEARCH REPORT

International application No.

PCT/US02/34253

A. CLASSIFICATION OF SUBJECT MATTER		
IPC(7) : A 61B 5/00		
US CL : 600/562		
According to International Patent Classification (IPC) or to both national classification and IPC		
B. FIELDS SEARCHED		
Minimum documentation searched (classification system followed by classification symbols) U.S. : 600/562, 563-569; 604/164.01-164.11, 170.01-170.03		
Documentation searched other than minimum documentation to the extent that such documents are included in the fields searched None		
Electronic data base consulted during the international search (name of data base and, where practicable, search terms used) WEST, EAST		
C. DOCUMENTS CONSIDERED TO BE RELEVANT		
Category *	Citation of document, with indication, where appropriate, of the relevant passages	Relevant to claim No.
A	US 6,110,128 A (ANDELIN et al.) 29 August 2000, see Entire Disclosure	1-23
A	US 6,086,543 A (ANDERSON et al.) 11 July 2000, see Entire Disclosure	1-23
A	US 5,477,862 A (HAAGA) 26 December 1995, see Entire Disclosure	1-23
<input type="checkbox"/> Further documents are listed in the continuation of Box C. <input type="checkbox"/> See patent family annex.		
* Special categories of cited documents:		
"A"	document defining the general state of the art which is not considered to be of particular relevance	"T" later document published after the international filing date or priority date and not in conflict with the application but cited to understand the principle or theory underlying the invention
"B"	earlier application or patent published on or after the international filing date	"X" document of particular relevance; the claimed invention cannot be considered novel or cannot be considered to involve an inventive step when the document is taken alone
"L"	document which may throw doubts on priority claim(s) or which is cited to establish the publication date of another citation or other special reason (as specified)	"Y" document of particular relevance; the claimed invention cannot be considered to involve an inventive step when the document is combined with one or more other such documents, such combination being obvious to a person skilled in the art
"O"	document referring to an oral disclosure, use, exhibition or other means	"&" document member of the same patent family
"P"	document published prior to the international filing date but later than the priority date claimed	
Date of the actual completion of the international search		Date of mailing of the international search report
26 December 2002 (26.12.2002)		06 MAR 2003
Name and mailing address of the ISA/US Commissioner of Patents and Trademarks Box PCT Washington, D.C. 20231 Facsimile No. (703)305-3230		Authorized officer Pamela Wingood Telephone No. (703)308-0858