

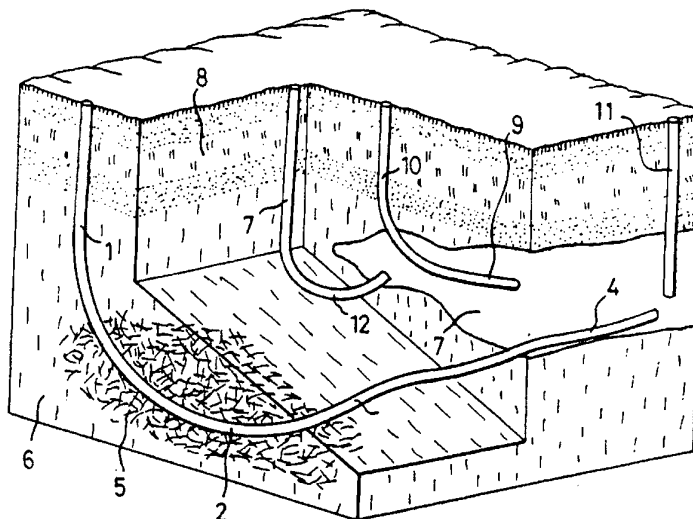

INTERNATIONAL APPLICATION PUBLISHED UNDER THE PATENT COOPERATION TREATY (PCT)

<p>(51) International Patent Classification⁵ : E21B 43/24, 43/25, 10/32, 4/18, 7/06, 10/62, 10/26, F04C 2/16, F03C 2/30, F24J 3/08, E21B 43/30</p>	A2	<p>(11) International Publication Number: WO 94/21889</p> <p>(43) International Publication Date: 29 September 1994 (29.09.94)</p>											
<p>(21) International Application Number: PCT/GB94/00515</p> <p>(22) International Filing Date: 15 March 1994 (15.03.94)</p> <p>(30) Priority Data:</p> <table border="0"> <tr> <td>9305532.5</td> <td>17 March 1993 (17.03.93)</td> <td>GB</td> </tr> <tr> <td>9317690.7</td> <td>25 August 1993 (25.08.93)</td> <td>GB</td> </tr> <tr> <td>9319994.1</td> <td>28 September 1993 (28.09.93)</td> <td>GB</td> </tr> <tr> <td>9321003.7</td> <td>12 October 1993 (12.10.93)</td> <td>GB</td> </tr> </table> <p>(71)(72) Applicant and Inventor: NORTH, John [GB/GB]; 15 Lilian Close, Hellesdon, Norwich, Norfolk NR6 6RZ (GB).</p> <p>(74) Agents: STURT, Clifford, Mark et al.; J. Miller & Co., 34 Bedford Row, Holborn, London WC1R 4JH (GB).</p>	9305532.5	17 March 1993 (17.03.93)	GB	9317690.7	25 August 1993 (25.08.93)	GB	9319994.1	28 September 1993 (28.09.93)	GB	9321003.7	12 October 1993 (12.10.93)	GB	<p>(81) Designated States: AT, AU, BB, BG, BR, BY, CA, CH, CN, CZ, DE, DK, ES, FI, GB, GE, HU, JP, KP, KR, KZ, LK, LU, LV, MG, MN, MW, NL, NO, NZ, PL, PT, RO, RU, SD, SE, SI, SK, TT, UA, US, UZ, VN, European patent (AT, BE, CH, DE, DK, ES, FR, GB, GR, IE, IT, LU, MC, NL, PT, SE), OAPI patent (BF, BJ, CF, CG, CI, CM, GA, GN, ML, MR, NE, SN, TD, TG).</p> <p>Published <i>Without international search report and to be republished upon receipt of that report.</i></p>
9305532.5	17 March 1993 (17.03.93)	GB											
9317690.7	25 August 1993 (25.08.93)	GB											
9319994.1	28 September 1993 (28.09.93)	GB											
9321003.7	12 October 1993 (12.10.93)	GB											

(54) Title: IMPROVEMENTS IN OR RELATING TO DRILLING AND TO THE EXTRACTION OF FLUIDS



(57) Abstract

A first aspect of the invention provides a method of extracting fluid from a reservoir (7) of said fluid comprising the use of geothermal energy. Preferably, the method comprises the drilling of a well (1) into an area of geothermal energy (6) so as to enable release of the geothermal energy into the fluid reservoir (7). One configuration of wells is disclosed for the extraction of geothermal energy generally. In implementing the first aspect of the present invention it can be particularly beneficial to have the ability to drill horizontal and/or upwardly extending bores from a conventional downward extending well bore. Further aspects of the invention are concerned with the apparatus which enable such well bores to be drilled. These tools include: an adjustable reamer/stabiliser, a thrust calliper, a positive displacement drilling motor, a trajectory control unit, and ultralobe cavity trirotor positive displacement pump/motor, a trirotor mud drilling motor and a compensating underreamer.

FOR THE PURPOSES OF INFORMATION ONLY

Codes used to identify States party to the PCT on the front pages of pamphlets publishing international applications under the PCT.

AT	Austria	GB	United Kingdom	MR	Mauritania
AU	Australia	GE	Georgia	MW	Malawi
BB	Barbados	GN	Guinea	NE	Niger
BE	Belgium	GR	Greece	NL	Netherlands
BF	Burkina Faso	HU	Hungary	NO	Norway
BG	Bulgaria	IE	Ireland	NZ	New Zealand
BJ	Benin	IT	Italy	PL	Poland
BR	Brazil	JP	Japan	PT	Portugal
BY	Belarus	KE	Kenya	RO	Romania
CA	Canada	KG	Kyrgystan	RU	Russian Federation
CF	Central African Republic	KP	Democratic People's Republic of Korea	SD	Sudan
CG	Congo	KR	Republic of Korea	SE	Sweden
CH	Switzerland	KZ	Kazakhstan	SI	Slovenia
CI	Côte d'Ivoire	LI	Liechtenstein	SK	Slovakia
CM	Cameroon	LK	Sri Lanka	SN	Senegal
CN	China	LU	Luxembourg	TD	Chad
CS	Czechoslovakia	LV	Latvia	TG	Togo
CZ	Czech Republic	MC	Monaco	TJ	Tajikistan
DE	Germany	MD	Republic of Moldova	TT	Trinidad and Tobago
DK	Denmark	MG	Madagascar	UA	Ukraine
ES	Spain	ML	Mali	US	United States of America
FI	Finland	MN	Mongolia	UZ	Uzbekistan
FR	France			VN	Viet Nam
GA	Gabon				

Improvements in or Relating to Drilling
And to The Extraction of Fluids.

The present invention relates to drilling, apparatus therefor and to the extraction of fluids from reservoirs. In one specific application the invention relates to the extraction of oil and the like from underground or undersea reservoirs.

The extraction of oil from underground or undersea natural reservoirs, often referred to as oil recovery, has long since passed the stage of simple pumping techniques especially in relation to heavy oils. It is generally considered that the average initial recovery of oil from a reservoir is only about 20% of the oil in the reservoir. Particularly with a view to enhancing the quantity of oil which can be recovered from a reservoir and in some circumstances making extraction from certain types of reservoir or deposit feasible, it is known to use techniques such as hot water or steam flooding of an oil reservoir. These techniques consist of pumping hot water or steam, respectively, into the natural reservoir so as to reduce the viscosity of the oil or the like so as to enable it to be pumped more readily to the surface. Average oil recovery can be increased using these techniques to between 30 % and 50%, depending on the particular characteristics of the reservoir and the oil.

Despite relatively low current day oil prices, techniques as drastic as fire flooding have also been proposed and used. The fire flooding technique involves igniting part of the oil in the natural reservoir such that the heat thereby released lowers the viscosity of the remaining oil so that it can successfully be pumped to the surface. The detailed techniques are often quite complex, with variations such as forward and reverse combustion, additional air injection and the like. It is also known to pump solvents into an oil well in order to reduce the viscosity of the crude oil and so enable recovery thereof.

In the above mentioned "flooding" techniques energy has to be used to generate and apply the heat to the oil to be recovered. Typically, at least 25% of the recoverable oil resource is used (or the energy equivalent thereof) to generate the heat needed to facilitate recovery of that recoverable oil. For many years these techniques have been the best available, despite the enormously large financial gain from reducing the 25% or more wastage of the recoverable resource.

With a view, for example, to mitigating the above mentioned disadvantage, according to a first aspect of the present invention there is provided a method of extracting fluid from a reservoir of said fluid comprising the use of geothermal energy.

Preferably, the method comprises the drilling of a well into an area of geothermal energy so as to enable release of the geothermal energy into the fluid reservoir.

The applicant has invented an especially advantageous configuration of wells for the extraction of geothermal energy generally. Thus, according to another aspect of the present invention there is provided a method of extracting geothermal energy from the ground comprising the drilling of a configuration of wells as shown in figure 14A of the accompanying drawings alone or as shown in figures 14A and 15A of the accompanying drawings in combination.

In implementing the first aspect of the present invention it can be particularly beneficial to have the ability to drill horizontal and/or upwardly extending bores from a conventional downward extending well bore. Further aspects of the invention are concerned with the apparatus which enable such well bores to be drilled.

Thus, according to a second aspect of the present invention there is provided a tool for use in the drilling of wells, comprising a tool body and a plurality of segments movable with respect to the body in a radial direction with respect to the well bore.

Similarly, according to another aspect of the present invention there is provided a tool for use in the drilling of wells, comprising a main body, a calliper body, a plurality of segments movable with respect to the calliper body in a radial direction with respect to the well bore, and a mechanism for moving the main body with respect to the calliper body.

According to another aspect of the present invention there is provided a tool for use in the drilling of wells, comprising a body having first and second portions coupled by a joint wherein the joint is adapted to be controlled by fluid pressure so as to change the angle of inclination of the said body portions relative to each other.

According to yet another aspect of the present invention there is provided a tool for use in the drilling of wells, comprising a tool body and a plurality of segments movable with respect to the body with each segment having a cutting edge at one end thereof

and with movement of the segments being such that the said ends move in a radial direction with respect to the well bore.

According to yet another aspect of the present invention there is provided a pump/motor for use in the drilling of wells, comprising a housing having an internal helix, a fixed female external helix outer stator with an internal helix and a fixed male helix.

According to yet another aspect of the present invention there is provided a drilling motor for use in the drilling of wells, comprising an epitrochoidal rotary cylinder and a trirotor.

The various aspects of the invention will now be described by way of example only and with reference to the accompanying drawings, in which:-

Figure 1 illustrates a well drilled with a downward bore followed by a horizontal bore, by means of which three reservoirs of oil or the like are accessed;

Figure 2 illustrates a "U" shaped well in which a downward vertical bore 1 is followed by a short horizontal bore 4 and then an upward vertical bore 2;

Figure 3 illustrates a well which accesses two oil reservoirs;

Figure 4 illustrates the use of multiple bores extending from a common downward bore;

Figure 5 illustrates the use of multiple wells including in particular a well which passes through an area of geothermal energy and which subsequently extends into an oil reservoir;

Figure 6 illustrates the use of multiple "J" shaped bores extending from a single vertical bore and a subsequent horizontal bore;

Figure 7 illustrates an arrangement of wells which might be provided so as to apply geothermal energy directly to a reservoir of heavy crude oil;

Figure 8 illustrates an arrangement in which separate wells are used to create the artificial fracturing of the granite rock formation and to form a pathway for the geothermal energy to enter the oil reservoir;

Figure 9 illustrates a variation of the arrangement shown in figure 8;

Figure 10 illustrates a further arrangement in which a separate cold water injection well is used to create an artificial network of fractures in a granite formation;

Figure 11 shows a diagrammatic view of the drilling and production of an oil reservoir and a hot dry rock steam injection method;

Figure 12 illustrates an arrangement in which high flow rates are used;

Figure 13 illustrates an arrangement in which a shaft/tunnels are drilled and horizontal twin wells are drilled with coiled tubing units

Figures 14A & B show well injection and production geometry for high production flow rates with single injector well and twin trilateral production wells;

Figures 15A & B illustrate a plan views of the wells shown in figures 14A & B, respectively;

Figure 16 shows a radial cross-section of an adjustable rotary reamer/stabiliser;

Figure 17 shows a radial cross-section of an adjustable reamer/stabiliser blade with spherical cutter balls;

Figure 18 shows a radial cross-section of a reamer/stabiliser blade with cross cutting barrel rollers;

Figure 19 shows a radial cross-section of a reamer/stabiliser blade with vertical cutter rollers;

Figure 20 shows an axial cross-section of a reamer/stabiliser body;

Figure 21 shows a radial cross-section of a caliper thrust unit;

Figure 22 is an axial cross-section of the caliper thrust unit;

Figure 23 is an axial cross-section of the caliper thrust unit caliper body and hydraulic drill collar piston valve block assembly;

Figure 24 is a radial cross-section of a caliper thrust unit piston;

Figure 25 is a radial cross-section of the hydraulic drill collar piston valve assembly and cylinder body with telemetry unit controllers and valve control spool, telemetry unit controllers for dump valves;

Figure 26 is a radial cross-section of a telemetry control unit;

Figure 27 shows a radial cross-section of a dual acting telemetry unit controller;

Figure 28 shows an axial top section of a pivot ball joint;

Figure 29 shows an axial cross-section of the trajectory control unit, cylinder body and piston with piston guide control tube and rod;

Figure 30 shows a radial cross-section of a flexible connection;

Figure 31 shows a radial cross-section of a fluid dump valve;

Figure 32 shows a radial cross-section of a down-hole drilling motor;

Figure 33 shows a diagrammatic drawing of a drilling assembly for directional/horizontal drilling;

Figure 34 shows radial cross-sections of a telemetry unit controller;

Figure 35 shows radial cross-sections of a telemetry unit controller;

Figure 36 shows a radial cross-section of the toggle bar and toggle latch with latch plates;

Figure 37 shows a diagrammatic drawing of two single trajectory control units in a drilling assembly;

Figure 38 shows a diagrammatic drawing of a single trajectory control unit in a drilling system;

Figure 39 shows radial cross-section of an orientation unit;

Figure 40 shows a diagrammatic view of a twin bend housing assembly trajectory control unit;

Figure 41 shows a radial cross-section of a universal joint and output thrust shaft;

Figure 42 shows a radial cross-section of a trajectory control unit and down-hole motor sealed bearing assembly (single bend sub);

Figure 43 shows the main mechanism of the figure 42b arrangement to a larger scale;

Figure 44 shows a radial cross-section of a compensating underreamer, hole opener/milling tool;

Figure 45 shows epitrochoidal rotor/trirotor stator positive displacement mud drilling motor with fixed orbital trirotor stator and rotary epitrochoidal outer rotor with rotary stabiliser;

Figure 46 illustrates the position of the trirotor in the epitrochoidal rotary chamber of the motor shown in figure 45; and

Figure 47 shows a radial cross-section of a multiphase flow type ultralobe cavity trirotor pump.

Figure 1 to 13 inclusive show examples of the extraction of oil from an oil reservoir using the method of drilling into a an area of geothermal energy adjacent the oil reservoir. Although geothermal energy has previously been used, eg for the generation of electricity, it has not previously been proposed to use geothermal energy to aid in the recovery of heavy oils and the like.

It has been well known for very many years that molten rock lies beneath the earth's crust. The materials of the crust are poor conductors of heat and are cooled by ground water circulation. At sufficient depths, a steep temperature gradient exists - often as

high as 20°C/km or even 40°C/km. What is not well known, and what has not previously been utilised to any significant extent, is the fact that in most parts of the world temperatures sufficiently high to produce high pressure steam exist at depths which can be reached with conventional drilling techniques, namely of the order of 10km to 15 km.

The conventional methods of hot water or steam flooding are inefficient, since rapid cooling takes place as the water or steam is passed through pipes to the well and passes through the cool ground materials and/or seawater above the oil reservoir. Generation of the hot water or steam typically involves the burning of fuels which are environmentally damaging; causing acid rain, accelerating the destruction of forests and adding to global warming. Particularly for undersea oil wells, where the production of the hot water or steam must take place on the confined area of an oil platform, the risks arising from potential ignition of fluids from the reservoir are sufficiently great to prevent extensive use of such techniques. Techniques involving the use of solvents also involve a significant risk of causing pollution.

Use according to the present invention of geothermal energy can avoid the above mentioned difficulties associated with conventional techniques.

There are various methods by which geothermal energy can be applied to a reservoir of oil. One preferred method according to the present invention is to fracture the rock formations between the geothermal area and the oil reservoir. This involves engineering to provide artificial permeability of the rock formations. The engineering comprises the drilling of appropriately configured wells and the injection of a fluid, usually water under high pressure, to cause a network of fractures which will provide a pathway for the geothermal energy to be applied to the oil reservoir. Another preferred method involves the drilling of a well through an area of geothermal energy and extending the well beyond the area of geothermal energy into the oil reservoir. In an alternative arrangement, the well may be drilled through the oil reservoir and beyond the reservoir into an area of geothermal energy with subsequent blocking of the well above the fluid reservoir. In this arrangement preferably the well is blocked using a non-return valve, so as to permit the subsequent introduction downhole of any desired fluids.

Particularly in the above described embodiment in which a well is drilled into the geothermal area and subsequently into the oil reservoir, the well bore will often need to first extend down to the geothermal area and then extend upwardly to the oil reservoir.

Often it will also be desirable for the well bore to extend horizontally for part of its length. The drilling of upwardly and/or horizontally extending well bores is generally not feasible, or is inefficient and unreliable, using conventional drilling apparatus. Thus, in accordance with other aspects of the present invention there are provided various devices which enable the desired well configurations to be drilled with ease, efficiency and reliability.

Figure 1 illustrates a well drilled with a downward bore followed by a horizontal bore, by means of which three reservoirs of oil or the like are accessed for extraction of the oil. A downward, vertical bore 1 is drilled from the surface 6 through the layers of surface material 7. A generally horizontal bore 2 is drilled from the base of the vertical bore 1, so as to extend through one oil reservoir, 4, and into another, 5. A third oil reservoir, 3, is accessed via an upward directed bore 8 extending from the horizontal bore 2.

Figure 2 illustrates a "U" shaped well in which a downward vertical bore 1 is followed by a short horizontal bore 4 and then an upward vertical bore 2. Rock formations are indicated generally by reference 5 and reference 6 indicates a granite rock strata. High pressure water injected into the well bores 1,2 and 4 cause the granite to rupture, as indicated by reference 3.

Figure 3 illustrates a well which accesses two oil reservoirs, 4 and 5. First a downward bore enters the first oil reservoir and the bore is then extended in a generally horizontal direction, at section 2, followed by a short upward bore 3 and finally another horizontal bore 7 which extends into reservoir 4. Reference 6 indicates the layers of surface material.

Figure 4 illustrates the use of multiple bores extending from a common downward bore, 1. The bottom of bore 1 branches into two bores which extend into different parts of a large oil reservoir 5. One of the two bores, bore 2, is a generally horizontal bore. The other of the two bores, bore 3, has a horizontal portion followed by an upward portion. The upward portion extends into the second oil reservoir, 6. A third bore, 4, extends into reservoir 6 from a side wall part way down the downward bore 1. Reference 7 indicates the layers of surface material.

Figure 5 illustrates the use of multiple wells including in particular a well which passes through an area of geothermal energy and which subsequently extends into an oil reservoir. Reference 8 indicates layers of surface material and reference 6 indicates a granite rock formation which has been artificially fractured, as indicated by reference 5. The well extending through the geothermal area comprises a downward bore 1, an upward bore 3 and a generally horizontal bore 4. Bore 4 extends into the oil reservoir, 7. Geothermal energy enters the well in the region of the artificial fractures 5 and passes along the well to reach the oil reservoir 7. The vertical bore 1 may be blocked off as appropriate. Geothermal energy entering the reservoir 7 reduces the viscosity of heavy crude oil in the reservoir and thus enables the recovery thereof via the three

additional wells which are independently drilled from the surface into the reservoir 7. The three additional wells are included so as to illustrate the various configurations which might be used. One of the additional wells consists of a simple vertical downward bore 11. Another of the wells comprises a downward bore 10 followed by a generally horizontal bore 9. The third additional well has a generally "J" shaped configuration, with a vertical bore 7 and a curved extension , 12, at the end thereof.

Figure 6 illustrates the use of multiple "J" shaped bores 3 extending from a single vertical bore 1 and a subsequent horizontal bore 2. References 5 and 6 indicate rock formations and reference 4 indicates the crude oil reservoir.

Figure 7 illustrates an arrangement of wells which might be provided so as to apply geothermal energy directly to a reservoir of heavy crude oil, so as to enable the recovery of oil which might not otherwise be possible. A vertical bore 6 is drilled from the surface 1 through rock formations 2, 4 until an area of granite 5 is reached. A generally horizontal bore 7 is drilled in the granite formation, or along the surface thereof.. The well is extended beyond the granite area by an upward bore 8 so as to reach a reservoir of heavy crude oil 3. Within the reservoir the well continues as a generally horizontal bore 9, so as to increase dispersion of geothermal energy within the reservoir. The granite lies above an area of geothermal energy and is artificially fractured by the injection of high pressure cold water into bores 1 and 7. A separate well is used for extraction of the reduced viscosity oil. The extraction well comprises a vertical bore 11 drilled from the surface 10 and an upward bore 13 and a horizontal bore 14 which extend from the bottom of the vertical bore 11 into the reservoir 3.

Figure 8 illustrates an arrangement in which separate wells are used to create the artificial fracturing of the granite rock formation and to form a pathway for the geothermal energy to enter the oil reservoir. Three wells are shown in total, one being a cold water injection well for fracturing the granite and the other two being oil extraction wells which penetrate the oil reservoir 4. Each of the three wells are drilled from the surface 1 through surface rock formations 2 and 3. The cold water injection well comprises a bore 7 which extends down to the granite formation 5. Each of the two wells entering the oil reservoir comprise a downward bore 9 continuing into at least one further bore. In one case the further bore is a generally horizontal bore 8 and in the other case multiple bores extend from the vertical bore. The multiple bores comprise a "J" shaped bore and a generally horizontal bore 11, both of which access different parts of the oil reservoir. The horizontal bore is drilled laterally from the

vertical bore of the "J" and below that junction a downward bore 10 is drilled to access, via a subsequent horizontal bore 12, the artificially fractured granite.

A variation of the arrangement shown in figure 8 is shown in figure 9. Again a separate well, 7, is used for the formation of an artificial network of fractures, 6, in a layer of granite, 5. An extensive reservoir, 3, of heavy crude oil is accessed by a plurality of wells. One of the wells is shown as having dual horizontal bores extending within the reservoir from the bottom of a vertical bore 8. Another well has a configuration which may be referred to as generally "S" shaped. That is, the well comprises a vertical bore 10 drilled from the surface 1 through surface layers of material 2 followed by a horizontal bore 11 which extends within the oil reservoir and finally a downward bore 12 which passes through various rock formations 4 below the oil reservoir so as to reach the fracture network 6 in the granite. An additional horizontal bore 11 is drilled laterally from the base of vertical bore 10 and the well is blocked off, preferably using a non-return valve 13, just above the base of the vertical bore 10. The well thus acts as a pathway for wide dispersal of geothermal energy within the oil reservoir.

Figure 10 illustrates a further arrangement in which a separate cold water injection well, 7, is used to create an artificial network of fractures, 6, in a granite formation 5. An additional side bore 8 is used to extend the area of artificial fracturing. A single large diameter bore 9 is drilled from the surface 16 vertically into an extensive reservoir 3 of heavy crude oil. Multiple bores are drilled from the base of bore 9. A "J" shaped bore 14 and a horizontal bore 13 access different parts of the reservoir. Two "S" shaped bores 11 and 12 extend through rock formations 4 below the reservoir and access the artificial fracture network.

Crude oils below 20 degree API gravity are usually considered to be heavy. The lighter conventional crudes are often waterflooded to enhance recovery. The injection of water into the reservoir helps to maintain reservoir pressure and displace the oil toward the production wells. In general waterflooding is most effective with light crude oil of 25 degree API gravity and higher and becomes progressively less effective with oils below 25 degree API. with crudes of 20 degree and lower, waterfloods are essentially ineffective and thermal recovery becomes necessary. Very few thermal projects are successful in recovering oil of less than 10 degree API gravity. Heavy crude oils have enough mobility that, given time, they will be producible through a well bore in response to thermal recovery methods. Tar sands

contain immobile bitumen that will not flow into a well bore even under thermal stimulation.

For world production of oil of all types, primary recovery (flowing and pumped wells) averages about 20 percent of in-place oil. Secondary recovery methods (waterflooding or gas injection) are used in an effort to maintain or restore reservoir pressure and can improve recovery from 30 to 50 percent of the in-place oil, depending on reservoir conditions and oil properties.

Enhanced recovery processes are designed to reduce oil viscosity and capillarity by introducing into a reservoir other substances, such as carbon dioxide, polymers, solvents and micellar fluids in various combinations. Processes of this sort can further increase recovery from 40 to 80 percent of the in-place oil.

Thermal recovery methods are used to enhance the production of heavy crude oils, the recovery of which is impeded by viscous resistance to flow at reservoir temperatures. The recovery of the immobile oil in tar sands that will not flow even in response to thermal stimulation requires mining.

This is no longer a problem with the ultradeep crude technology (UCT) method as total heat at varying depths can now be placed directly into the oil bearing formation from the underlying hot dry rocks (HDR) reservoir and various types of horizontal "J" and "S" type production well bores to drain the reservoir.

Energy from accessible regions of hot rock beneath the earth's surface that do not contain sufficient natural porosity or permeability, energy can be extracted from artificially fractured reservoirs that emulate natural geothermal systems. The primary technique for engineering these so-called hot rock (HDR) geothermal reservoirs utilises fluid pressure to open and propagate fractures from an inclined well, creating artificial permeability within a fracture network. This hydraulically stimulated region is then connected to a second well to complete the underground system. Heat is extracted by circulating water from the surface, down one well, through the fractured rock network, and up the second well. The heated water then passes through an appropriately designed power plant on the surface where, for instance, electricity or process steam is generated. The cooled fluid is then reinjected to complete a closed loop cycle. Thus, effluents from HDR systems are practically non-existent.

Because hot dry rock systems do not require contained hot fluids and high permeability, the HDR resource - the accessible thermal energy in the earth's crust - is much larger and more widely distributed than natural geothermal systems. Numerous estimates place the accessible HDR resource base somewhere between 10 and 13 million quads in the U.S.A., and over 100 million quads worldwide. Accessible is defined as the normal depth attainable using conventional drilling technology (about 10 Km).

The recovery of heavy crude oils is impeded by a viscous resistance to flow at reservoir temperatures. The heating of heavy crudes markedly improves their mobility and promotes their recovery. Heat may be introduced into the reservoir by injecting a hot fluid, such as steam or hot water, or by burning some of the heavy oil in the reservoir (a process referred to as in situ combustion or fire flooding).

The bitumen in tar sands can be recovered by surface mining methods.

A common method involving the use of steam to recover heavy oil is known as steam soak, or cyclic steam injection, it is essentially a well-bore stimulation technique in which steam generated in a boiler at the surface is injected into a production well for a number of weeks, after which the well is closed down for several days before being put back into production. In many cases there is a significant increase in output. It is sometimes economic to steam soak the well several times, even through heavy oil recovery using declines with each succeeding treatment. Steam soaks are economically effective only in thick permeable reservoirs in which vertical (gravity) drainage can occur.

Continuous steam injection heats a larger portion of the reservoir and achieves the most efficient heavy oil recoveries known are steam flooding, this technique is a displacement process similar to waterflooding. Steam is pumped into injection wells and the oil is displaced to production wells.

Because of the relatively high cost of steam, water is sometimes injected at an optimum time to push the steam toward the production wells. Since the steam serves two functions, the heating and transporting of the oil, some steam must always be circulated through the rock formation without condensing. Even in some of the most favourable reservoirs, it is necessary to consume an amount of energy equivalent to burning roughly 25 to 35 percent of the heavy oil produced in order to generate the required amount of steam. The mechanics of heavy oil displacement in an in situ combustion operation is similar to that in the steam-flooding process. Steam is produced by vaporising water that has been injected therein with heat from the in situ combustion of some of the oil in the reservoir. After the in place heavy oil has been ignited the burning front is moved along by continuous air injection, in one variation of the in situ combustion process known as forward combustion, air is injected into a well so as to advance the burning front and heat and displace both the oil and water to surrounding produced wells.

A modified form of forward combustion incorporates the injection of cold water along with air to recover some of the heat remains behind the combustion front. The air-water combination minimises the amount of air injected and the amount of in-place oil burned (to between 5 and 10 percent), in another variation of in situ combustion called reverse combustion, a short-term forward burn is initiated by air

injection into a well that will eventually produce oil, after which the air injection is switched to adjacent wells. This process is used for recovering extremely viscous oil that will not move through a cold zone ahead of a forward-combustion front.

The costs associated with the generation of heat within a heavy oil reservoir and the success of the recovery process are influenced by the depth of the reservoir.

In general shallower reservoirs are candidates for steam soaks and steam floods while deeper reservoirs are for in situ combustion. Solvent extractions also have been used to recover heavy oils, in this process a solvent emulsifying solution is injected into a heavy oil reservoir. The fluid dissolves or emulsifies the oil as it advances through the permeable reservoir. The oil and fluid are then pumped to the surface through production wells. At the surface, the oil is separated from the fluid and the fluid is recycled.

The ultradeep crude technology (UCT) uses the method of hot dry rock (HDR) geothermal energy (high pressure steam) to utilise natural heat contained in the earth's crust for thermal enhanced oil recovery, it can provide a non-polluting energy in the form of high pressure steam or hot water.

Few people have considered that the earth's internal heat is one of our largest supplies of energy, in fact almost anywhere in the world it is already possible to drill holes deep enough to reach temperatures sufficiently high to produce high pressure steam and high pressure water, this heat, geothermal energy, is produced mostly by disintegration of naturally occurring unstable forms of uranium, thorium and potassium because the rocks soil and gravels that make up the earth's outer crust conduct heat poorly, much of the heat remains stored in the solid rock at considerable depth in most places a hole drilled from the surface passes first through layers of sediments and fractured rock that are kept cool as ground water circulation temperature begins to increase quite rapidly as typically occurs in any insulating material between a hot body and its cool surroundings this temperature increase and the increasing pressure of the material above it cause the rocks to become progressively drier as well as hotter, the typical hot dry rock (HDR) situation worldwide. It can help mitigate the continued warming of the earth through the greenhouse effect and the accelerating destruction of forests and crops by acid rain, two of the major environmental consequences.

The use of fossil fuels to run steam generator plants to produce steam to thermally enhance reservoirs on and offshore to produce oil that would not otherwise be recoverable from 5 degree API and above, one offshore field discovered north of the Shetlands was capped and abandoned as the viscosity of the oil in place was 25 degree API it was not fluid enough to be produced without steam, that could not be produced offshore until now with this (UCT) production system.

HDR energy (steam) or high pressure hot water is available virtually everywhere on the earth's surface with the resources temperature inexorably increasing with depth. The actual quality or grade of the (HDR) resource at a specific location will control development costs, the primary parameter determining the local grade of the resource is the average temperature gradient or conversely the drilling depth required to reach a temperature suitable for the specified thermal enhanced oil recovery, either high pressure steam or hot water. Unlike hydrothermal or geopressured resources that require indigenous hot fluids, hot dry rock systems need only hot rocks at accessible depths in the earth's crust (HDR) resources range from low-grade regions having normal to near normal temperature gradients of 20° C to 40° C/km to high grade regions with above-normal gradients greater than 40°C/km. The lower-grade gradients is distributed more or less uniformly throughout the world. While the higher grade resources are found frequently within or near active natural geothermal areas.

For the (HDR) concept to work in practice the underground system must be properly engineered, a large open fractured reservoir should be created providing artificial permeability where it does not exist naturally to permit efficient heat extraction by circulating water in addition, optimally placed well(s) that maximise the efficiency of the heat-mining process must access the reservoir stimulation methods in the hot crystalline rock are used to properly engineer an (HDR) system. A method of drilling "J", "U" and "S" type wells and horizontal branch from the "J" loop for oil and gas hot rock geothermal and heavy oil and tar sands production with the use of caliper thrust units (CTU) (hydraulic) used to thrust forward, (add weight) to the drill bit with the aid of a drilling mud motor with near bit stabiliser unit used in conjunction with coiled tubing or drill pipe.

To recover heavy oil, tar sands and oil shale the technical criteria requires:-

- A. Ability to generate heat into the reservoir at efficient rates.
- B. Ability to displace the heated oil.
- C. Ability to recover the oil in a controlled manner.

An initial well is drilled into non-porous porosity of 1 part in 10000 granite. The well at this point is drilled horizontal to a given point then drilled upwards in a "J" type configuration into the oil bearing formation and if necessary can even be taken along horizontally from the top of the vertical "J" or "S" loop or by injection well and production extraction well drilled laterally or horizontally through the oil bearing formation then vertical or laterally down in to the HDR reservoir the extraction well is then plugged back above the oil formation. Production wells are then pattern drilled into the reservoir from the surface, with hot water the gas phase can be supplied by carbon dioxide CO₂ or nitrogen injection into the (HDR) reservoir on the closed loop

system, to fully sweep the oil reservoir. The main cold water injection line into the (HDR) in the horizontal section is fractured along its length, cold water is injected into the well at pressure to hydraulically fracture the (HDR) reservoir to produce super heated steam at very high temperatures above 300°C depending on the depth of the injection well. A method to produce steam by (HDR) is by an injection well, and a second intersecting well into the fractured zone to produce well head steam, but obviously steam driven to the surface then fed by flow lines to various parts of the field for re-injection into the oil reservoir would be costly and would lose temperature very quickly, in the same way as produced steam by steam generation on the surface. The (UCT) method quickly places the total heat from the steam/hot water directly into the oil reservoir driving the oil to the production wells in the pressurised closed HDR circulation loop.

Subterranean hot spots are so wide spread all over the world with (HDR) reservoirs created in myriad locations such as offshore, as all oil fields have underlying granite formation with subterranean hot spots that can be utilised. Above average values of heat are obtained when hot rocks are overlaying by thick sediments of hydrocarbon that provide insulation.

The bore hole is drilled to target depth, then the water is pumped in to the well bore at pressure. This, combined with depth of head pressure in the well bore column of thousands of feet, makes the pressure at the well bottom far too great for the rocks to resist, so they simply fracture, explosive charges may be used to induce fractures. The water is then forced up through the horizontal or lateral and up the "J" loop vertical of the well bore and comes out as superheated steam in the oil, tar sands, or, oil shale formation where the pressure and heat is so great that the oil is forced up through the production well bore system under pressure to the well heads to the separation and extraction plant where the cold water is then returned back down the injection well on a closed loop system. Further injection of solvents and or gas may also be injected into the well bore injector, producing large quantities of super heated steam or hot water and follow up hot water sweep after the steam breakthrough which correspondingly lowers oil to steam ratios to up to 50% attributing higher recoveries. The (UCT) high pressure method of steam drive makes this a very attractive proposition even with low well head prices.

By making optimal use under the (UCT) method steam and hot water in the early stages of the project in addition to limiting wastage of heat, it is expected that the steam or hot water that is kept in the formation in this way will ultimately improve the oil production from the other producers.

Also selective production from the deeper parts of the reservoir can be expected to induce steam or hot water entry into this reservoir area or other underlying

formations and improve the vertical steam/water distribution with a very high oil to steam/water ratio is expected production water is fully recycled so it is returned to the (HDR) injection well, sea water under offshore is ideal for this process flashing the brine back by return line may also be needed in this process to keep the reservoir fractures clear.

High pressure hot water can be produced at about 130 degrees C and above at lower drilling depths, this would be ideal for hot water at pressures from 1,000 to 4,000 PSI depending on the formation with ultra high flow rates delivered by high pressure pumps to fully sweep the whole of the reservoir to ultimately improve the heat flow within the reservoir.

It has been impossible to exploit for crude oil, heavy crudes, tar sands and oil shales economically and environmentally under reservoir conditions until now, and was not possible offshore. Production at any depth by the (UCT) method under pressure in the formation with vertical, lateral and horizontal well bores, considerable amounts of crude can now be produced by pressure fracturing. Injection is controlled from the HDR injection well by the cold water and/or carbon dioxide CO² into the oil reservoir from the hot rocks then superheated steam or hot water is driven up at pressure via the vertical or horizontal well through the vertical "J" loop well bore into the oil reservoir, the pressure forces the crude oil through the production well bores drilled into the reservoirs outlying wells, they will need to be piped into the closed loop system as the hot front is pushed towards them as the pressure lowers at the furthestmost point of the reservoir. A fracture occurs in the hydraulically connected oil bearing sand in the well bore when hydraulic pressure in the hole is larger than the stress produced by the overburden weight.

A vertical bore is drilled to target depth below the oil reservoir, then drilled horizontally under the reservoir (large bore holes can then be drilled with the TCU method) then multiple vertical upward bores are drilled into the oil reservoir. The oil flows into horizontal collection bore area by gravity and is pumped to the surface under pressure by the main vertical bore to the wellhead on a closed loop system. This method is extremely efficient at extracting most of the oil from the reservoir. The system can be used in conjunction with (HDR) (EOR) thermal steam drive Fig. 2, 5 and 8 "J" type drilling.

The process of high pressure reservoirs is derived from the capability of hydrocarbons to dissolve in water at near critical conditions so the pressure is above 3000 PSI and temperature above 300 degrees centigrade, and are efficient in densely fissured reservoirs for heavy and light oil, temperatures of 380 degrees centigrade to 480 degrees centigrade are required for oil shale recovery, so deeper well bores are required.

To drill extended reach horizontal wells and vertical wells from the horizontal and horizontal wells from the vertical known as "S" "U" and "J" type drilling and horizontal from the "J" type loop drilling for oil, gas, hot dry rock geothermal, heavy oil, tar sands and oil shales and production wells with the use of thrust calliper units (hydraulic) used to thrust forward (add weight to the drill bit or bits) along with the trajectory control drilling mud motor with near bit stabiliser all used in conjunction with coiled tubing or drill pipe. The coiled tubing carries an internal multicore electrical conduit for control purposes (MWD) improving drilling control, to improve the link between the coiled tubing unit for drilling (MWD), exploration, production and work-over wells from the smallest to the largest wellbores.

This method is also efficient for producing lower pressure/temperature steam/hot water into the reservoirs by the (HDR) method at lesser drilling depths. The HDR geothermal concept is a proven method of producing high or low pressure steam and or hot water no obstacle has been found that would hold back its development, HDR reservoirs can be found in regions of previously impermeable crystalline rock with thermal/flow properties to allow for efficient heat/steam flows, in New Mexico (HDR) temperatures were as high as 232 degrees centigrade at under 4km depth, and to create even larger HDR reservoirs you would only need to pump cold water down for longer periods of time since the reservoir producing the steam volume is directly proportional to the amount of water injected in to the HDR reservoir, so one would only need to hydraulically fracture the reservoir at the outset.

Water under high pressure can be used to open and extend the fractured area. This dilated region of hot jointed crystalline rock is referred to as (HDR) hot dry rocks, the drilling of the vertical/lateral injection well or wells bore and the production wells or wells vertical lateral then into the horizontal, then vertical again into the HDR reservoir.

The producing steam well bore can either be plugged above the oil bearing zone or a none return valve placed down hole so as to allow for injection or other agents, and temperature recording equipment as shown in Fig. 9 item: 13 further side tracked horizontal wells can also be drilled from each vertical bore as item: 9 further steam injector horizontal bore can also be run from producing steam well shown in Fig. 9 item: 11, the scope to drill this type to produce (HDR) steam injected into an oil bearing reservoir from underneath has vast enhanced oil recovery potential and is the most economical way to produce oil from a reservoir and the only way in which to produce heavy oil offshore and above all is environmentally safe, with abundance of water. UCT steam or hot water is injected continuously from one well bore or more upwards from hot dry rocks (HDR) into the reservoir causing the viscosity of the oil to be reduced until it becomes mobile and can be displaced or produced by gravity

drainage or vertical and horizontal in surrounding wells in a closed loop or open system. The principal advantage is high pressure, volume and heat retention in the process of steam transmission to the oil reservoir. When the steam is driven upwards and forward into the reservoir, it is the only safe method to produce ultradeep oil bearing formations also with the possible aid of injecting high temperature super critical carbon dioxide CO² in to the (HDR) reservoir increasing recovering efficiency due to the action of CO² with oil or other types of stimulants and the resulting displacement and sweep efficiencies. UCT high grade steam quality will enter into sand body to allow partial coking or in-situ sand consolidation without undue reservoir permeability damage.

Wells over 5,000 feet in depth could not normally be drilled for use with generated steam to enhance oil recovery because heat loss would be great and efficiency so low that steaming is not a viable technique, the UCT method overcomes all of these problems as the total heat is placed where it is most needed in the oil bearing formation, there is no limitation to depth of oil production with this (UCT) method, this method also increases the amount of original oil in place (OOIP) to be produced as none is used to produce the steam normally, between one third and a quarter of all oil produced is used by the steam generators to produce the steam. This alone is a tremendous cost saving. When using the (UCT) method it allows you to drill larger bore holes to inject steam in to the reservoir at much larger quantities than surface type injection methods, also with long horizontal (HDR) drilled sections to cover all points of the reservoir for high pressure fracturing and steam drive of soak. The basic difficulty was distributing heat induced into the reservoir along with the total volume of the oil heavy crude, tar sands and oil shale increasing their viscosity and making them mobile. This is now possible with the use of the (UCT) method when the high pressure steam or other agent is released into the formation (reservoir) from underneath the reservoir in horizontal and "J" type drilling (large bore drainage system) the pressure is so great with high injection rates forming fractures and fissures for the heating up of the reservoir oil by uniform thermal stimulation of the reservoir.

With this efficiency of the warm up in saturated adjacent zones by means of thermal agent injection temperatures of 200 degrees C to 500 degrees C are possible for the stimulation of the reservoir by bottom hole reservoir injection in the active zone between injection and production wells temperature is dependent on the depth and heat flow gradient of the underlying basement (HDR injection well or wells), the heat flow in granite, projected bottom hole temperatures increase with different crustal successions of sedimentary rocks / shale / coal / limestone / mudstone / sandstone to cover 200 degrees C at 4km depth with all granite formation temperature is only about

120 degrees C for the same depth the main temperature in underlying granite formation is about 30 degrees C for each 1km depth.

In high grade (HDR) resources drilling will result in significantly lower reservoir development costs for example, for a 60 degree c/km resource one needs only to drill to about 4km (13,000 feet) depth for initial rock temperatures of about 250 degrees C.

Heavy oil deposits require the creation of fractures to induce artificial injectivity and significantly enlarge the interface between oil sands and injected fluid. This improves heat transfer by convection and conduction fractures created during the stimulation process are acting as natural channels for fluid and heat transfer into the reservoir.

The UCT method is expected to be used for either high pressure, low volume steam/hot water or low pressure, high volume steam/hot water and high pressure high volume steam/hot water.

As steaming temperatures continue through the reservoir, the heated oil is driven to the producing wells by a complex array of displacement mechanisms including hot gas driven water displacement, hot water drive and steam or solvent assisted steam/hot water drive in a closed loop system.

Injection of fluids at significant rates can only be achieved by exceeding the parting or fracturing pressure of the formation continued injection with only partial withdrawal of fluid can cause reservoir pressures to increase until in-situ formation stresses are exceeded, this high pressure injection can induce formation movement, good communication between the injector wells and producers is vital for maximum production in this closed loop system.

The major thermal losses from conventional steam generators can be categorised as follows:-

- A. Steam generator inefficiencies chiefly heat losses in the existing gas flue gas.
- B. Heat loss from surface transmission lines.
- C. Down hole heat losses - function of well construction and steam temperature.
- D. Ancillary equipment and pollution control equipment utility control equipment.

Excessive water production in a field can be drawn and re-injected down the HDR injection well. Engineering and cost considerations are foremost in simplicity with pressurised hot water for enhanced recovery in all type of reservoirs high viscosity crudes, heavy crudes and tar sands in commercial quantities, with heat content of the (HDR) water/fluid transferred to the oil reservoir unlike generated heat from a small amount of steam fraction obtained by flashing the hot water, a continuous hot water flood would be superior to steam injection by oil field generators in some reservoirs.

The normal method of steam drive has always been used from the surface down to the formation and never upwards into the formation from underneath the reservoir. With superheated steam the method of fractures and channelling for efficient sweep of the reservoir by steam drive (flooding) to increase ultimate recovery using this (UCT) method in the reservoir in the high injection rates can give rise to reservoir channels and subsequent oil flows.

Normal steam drive, flood, cyclic thermal recovering uses large amounts of produced crude to operate the steam generator with the limited depth restrictions due to heat loss and very expensive to run. With the (UCT) method there are no heat losses, no running costs, other than the cold water injection, with at least a twenty five year life span before deepening or expanding the HDR reservoir, with no air pollution, this will allow the reservoir to remain very hot, accomplishing good production rates, about 600 tar sand occurrences are known to exist in the United States of America alone.

The handling of the effluent water is part of the production cycle being re-injected into the cold water injection well down to the hot dry rocks, again this may possibly be treated first, in some cases before being re-cycled for produced steam, again injection rates can be high and pressure also. It is also possible to inject raw sewage into the (HDR) reservoir to produce steam in the same way.

One major problem when using hot water or steam for enhanced oil recovery for increased production and extraction of oil from the reservoir, compared to conventional production methods, to produce one barrel of oil large amounts of hot water or steam has to be injected into the reservoir, but some of the produced water is obtained from underground wells, however the extra barrels of waste water produced could not be re-introduced back into the reservoir, only by re-injection into the reservoir of old gas wells, or through pipelines and pumping stations or by the costly method of vapour compressive plants to allow the re-use of the water in the environment, but with the HDR/EOR/thermal (UCT) method the solution to this problem is very simple, just increase the injection flow rate pressures to allow the (HDR) hot dry rock reservoir to grow in size to allow extra storage of produced water within the crystalline rock reservoir for future use, solving a major environmental problem when producing oil with minimal equipment cost on this closed loop system.

Enhanced oil recovery and heavy crude, tar sands by (UCT) method of production development on offshore platforms are far cheaper to produce with less equipment needed on the platforms, and could be the only method to steam drive a reservoir offshore, this alone is a tremendous cost saving offshore, due to government regulations covering oil fired boilers.

Steam or hot water injection is the most advanced enhanced oil recovery technology for crude oil production, in some cases it may be necessary to use additives, like foaming agents to plug the steam filled zones so that it is driven into those parts of the reservoir that are still saturated with oil, in order to increase the efficiency it is necessary to use additives to decrease interfacial tension and mechanical completions to allow for production after steam breakthrough.

Steam injection into a high fissured reservoir will preferably flow through the fissure and continuously condense against the walls of the matrix blocks until these blocks have reached steam temperature, the condensed water will be removed rapidly from the steam zone by gravity. As a result of the high fissure permeability during the heating process, oil will be expected from the matrix blocks as a result of the thermal expansion and thermally induced solution gas drive. The oil which amounts to some 15% of the oil in place is produced almost immediately and renders the recovery balance for the steam process right from the start.

Heavy oil occurrences of economic importance occur in most countries in sandstone or limestone at depths of between 150 ft and 1400 ft. As numerous evaluations show resources of oil shale in the world are very significantly larger than first thought running into trillions of barrels of oil. The oil shale reserves in Colorado, U.S.A., alone are 4-5 trillion short tons, oil shale, tar sands and heavy oil occupy the lower part of the hydrocarbon scale if they are located in the order of increasing density and viscosity. The deposits can be effectively developed only by using heat or hot agents, that is, by thermal methods, there are four methods to develop heavy crude, tar sands and oil shale deposits.

- A. Open pit mining plus hot agent processing of the rock in the plant.
- B. Mine development plus same as "A".
- C. Mine well drainage, drilling wells in the mine vertically and injection of hot agent heat into the well bore.
- D. Well drainage drilling the well from the surface injector of hot agent from the surface to the reservoir.

Most countries in the world have granite formations which underlie oil bearing formations, the granite formation has a high geothermal gradient potential for HDR/UCT production, the vast amount of heavy crude oil, tar sands and oil shale and conventional oil by the (UCT) enhanced recovery method. These resources are guaranteed for the future continuation of the oil industry.

Steam injection quality is the key factor in steam zone formation, some higher quality will be problematical. The effect of steam quality on oil recovery has a dual role, it determines heat input, and it also determines the two phase flow in the rock. The quality of steam can be controlled in hot dry rock enhanced oil recovery

(HDR/EOR) thermal ultradeep crude technology (UCT) by depth of hot dry rock reservoir, or with carbon dioxide CO², with a super-critical carbon dioxide condition.

The artificial lifting of crude oil from reservoirs with steam, hot water and water-flood creates constant changes that effect artificial lift design. The lifted liquid volume increases while the percent of crude oil in the produced fluid decreases. This increased expense and decreased return on capital will cause many producing wells to become marginal and some uneconomic, so the need to lift greater produced fluid volumes more efficiently is required. The closed loop production system with the ultradeep crude technology - hot dry rock - enhanced oil recovery is very efficient for this purpose, with very high injection and produced fluid flow rates with no extra artificial lifting equipment, with no restrictions on depth for producing reservoir fluid, work-over well costs are minimal, efficiency is high, capital costs low and environmentally good with high capital return.

Extra heavy crude oil, tar sands, and oil sands are bitumens or petroleum like liquids or semi solid occurring naturally in porous and fractured media, oil impregnated rock, bitumens have viscosities greater than 10,000 mPas. Crude oils have viscosities less than 10,000 mPas. These viscosities are gas free as measured and referenced to original reservoir temperature extra heavy crude oil have densities greater than 1,000 Kg per cubic metre (API gravities less than 10 degrees). Heavy crude oils have densities from 934 to 1000 Kg per cubic measure (API gravities from 20 degrees to 10 degrees inclusive). These densities (API gravities) are referenced to 15.6 degrees C (60 degrees F) and the atmospheric pressure.

Crude oil with densities less than 934 Kg per cubic measure (API gravities greater than 20 degrees) are classified as medium light, other crude oil below 20 degree API gravities are classified as heavy, extra heavy crude oil, tar sands, oil said and oil shale. These are world wide at depths as great as 14,000 feet in rocks of various lithologies and ages, in all climatic regions both on shore and offshore. A vast amount of reservoirs that have been discovered have been plugged and abandoned or else never tested. The amount of heavy crude oil also extra heavy crude oil, tar sands and oil shale resourced runs into many trillions of barrels.

Thermal processes are the predominant recovery methods the processes are primarily aimed towards a viscosity reduction and hence increase the mobility of this type of crude oil for production. The technological advances in the (UCT) recovery methods, if we take one oil field in California where 4000,000 barrel per day of heavy crude is produced in the field, to produce this, 100,000 of crude per day is required to run the steam generators, to produce the steam to recover the 4000,000 barrels, most of the oil produced in this reservoir ranges from 11 degrees to 15 degrees API. With the (UCT) method, the production would be 500,000 barrels per day, as no crude oil is

required to run the steam generators. If we take 18 USD per barrel, this is a saving of 1,800,000 USD per day, so using the (HDR) (UCD) method is a very small price to pay for the increased production, and will also be extremely economical.

The (UCT) method is expected to be used for either high pressure, low volume steam or low pressure high volume steam and high pressure volume steam. As steaming temperatures continue through the reservoir the heated oil is driven to the producing well by a complex array of displacement mechanisms including hot gas drive, water displacement, hot water drive and steam drive or solvent assisted steam drive and even compressed air within oil shale formation as air with oil is exothermal and will aid in the recovery of oil from the kerogen rocks by the large wellbore draining system and the (HDR) method. One of the North Sea oil fields, Efofisk, in the Norwegian sector, used cold water re-injection for the EOR to recover extra oil in place within the reservoir, thermal recovery would have been much more productive, with a far greater recovery rate. but, the well was offshore and the depth of the reservoir was too great, for it to be used.

With the (UCT) method it can now be used to recover even more oil, within the reservoir, obviously these numbers are small, compared to the Venezuelan Orinoco deposits, if the production reached 10,000,000 barrels per day, and the savings on that level of production are enormous. The heavy oil deposits of Canada, Venezuela, Columbia, U.S.A, the Russian Commonwealth of Independent States and China, amount to over twelve trillion barrels, even two trillion barrels of crude produced, would still be twelve times as much as Saudi Arabia's stated recoverable reserves of 165 billion barrels.

Development of the economically marginal resources, and the development of increased recovery efficiencies (EOR), a vast amount of heavy crude, tar sands and heavy shale are present in the world. The very best extractions costs are one barrel burnt to produce the steam for about twenty barrels produced, but normally it is one barrel used to produce the steam, for every three produced. Environmentally and equally important is the sulphur and nitrogen sulphides from the stack gases by scrubbers. The recovery factor using (UCT) method could include increase recovery rates of over 90% of the oil in place in the reservoir with this new innovative production technology (UCT) these include water, gas, solvent, surfactants and polymers.

The ideal way to produce the oil from the reservoir is to drill vertical, then horizontal under the formation, then vertical into the reservoir using the (UCT) drilling method with large bore hole as described in figure 6, with the use of "J" type well drilling, and using the horizontal well for collecting the oil by gravity drainage, then produced to the surface by the vertical well.

The drilling of "J" type wells can be of large diameter, the geology of all oil fields are a crystalline basement under sedimentary basins are constituted by metamorphic volcanic rocks and granite. The very high cost of high pressure steam injection from the surface normally makes uneconomical to produce crude oil until now. Vast heavy oil occurrence offshore underlying the huge Frigg and Heimdal gas fields in the Norwegian sector of the North Sea, the Bressay fields, also close to the Ninian field, and the Clair field in the U.K. sector, and the Den-Helda field in the Dutch sector of the North Sea.

The depth of each underlying granite formation will vary in each location hot spots are found at a depth from 30 degrees C per kilometre depth and above to 70 degrees C km.

The right kind of low conductivity sediment layer with different crustal successions can effectively insulate the buried granite further enhancing its geothermal potential and obviating the need for excessively deep drilling.

There is a granite layer in the earth's crust which completely surrounds the earth. This granite layer is relatively hot compared to surface temperatures. In some areas of the world, it is close to the surface, and in others, it is buried below miles of surface formations. The first step in the process of recovering the heat energy from this layer is to drill an injection well into the HDR formation which has very low permeability (e.g. granite) and sufficient temperature (preferably 240° to 330°C). Next, artificial fractures are created and held open in the rock formation using hydraulic stimulation techniques. Once the fracture system is created, one or more productions wells are drilled into the fracture zone so that they connect the fracture system to the surface. Water is then circulated under pressure from the surface into the injection well through the fracture system where it collects heat energy from the hot rock formation, and then to the surface where the heat energy is extracted from the water using a heat exchanger. The cooled water is then reinjected into the injection well starting the cycle over again. The low permeability of the fractured reservoir prevents most of the water from being lost, creating a closed loop system of continuous circulation. Backup water reservoirs on the surface are used to supplement the injection well as necessary to keep the reservoir fully charges with fluid until the reservoir size has stabilised. The heat energy thus collected on the surface may be used directly to heat the oil reservoir or make electricity. The system for mining heat energy from hot dry rock (HDR) is essentially pollution free, as compared to conventional steam power generation plants, which create heat energy by burning fossil fuels. The well configurations shown in figures 14 and 15 of the accompanying drawings are especially beneficial and are estimated to be capable of potentially reducing the cost of geothermal generation by as much as 80%.

Well-Bore Drilling Trajectory Development for Production Wells

By ultra-extended reach horizontal wells "J" shaped wells, reverse wells that are deviated to the horizontal load, drilled laterally through a section of the pay zone then deviated upwards, the upward direction to achieve:-

- (a) To drill into a second target or pay zone areas
- (b) Extending recovery high into the pay zone area
- (c) To place injector high into the reservoir
- (d) Underground access technology, large bore holes are drilled vertically so it reaches under the oil reservoir from which wells can be drilled vertically upwards to the reservoir, draining the reservoir by gravity is extremely efficient
- (e) Horizontal well sections will be lined with slotted liners
- (f) Injector and injector producers well bore or bores are on a closed loop production system

All this achieved with the use of the thrust calliper unit trajectory control drilling motor.

Drilling with Coiled Tubing Units

To drill large diameter or slimhole and horizontal "J" and "U" type wells a downhole thruster tool is extremely useful to drill long reach wells with coiled tubing or drill pipe together with special guidance tools, better downhole motors and drill bits to make the hole with light pressure. With coiled tubing you cannot rotate the string so normal methods do not allow for rotation of reamers/stabilisers and normal use of directional control unit overcomes all forms of directional well control from the surface, unlike the normal method where tripping the drill string from the hole is needed to replace directional control tools in the drill string.

This method opens up a completely new field of drilling practices together with cost saving in exploration and production drilling using coiled tubing drilling units or conventional drill pipe, coiled tubing can be tripped in very fast and out of the well with continuous fluid circulation. Unlike normal rotary drilling, bottom hole conditions can be monitored with through tubing electrical cables, kill weight drill fluids are not required to control the well. Multiple bores can be drilled from the one bore, drilling can take place with the well under full pressure, back wrapping of the pipe (tube torquing) is overcome with the thrust calliper units drilling vertically, horizontal "U" and "J" type wells is now possible and even drilling horizontal from the vertical loop of the "J" type well.

The downhole positive displacement motor (PDM) is also very advantageous in a drilling system. This invention employs trajectory control unit with the drilling motor and sealed bearings with stabiliser body which will propel itself by hydraulic thrusters, thrust calliper units anchored against hydraulic drill collars that grind the well bore. In place of the drill collars the system eliminates the need for drill string weight on the drill bit and eliminates the limitations of compressively loading the lower part of the drill string to push the bit through the vertical and horizontal and the "U" type drilling. Wells which are deviated to the horizontal mode, drilled laterally through a section of pay zone then deviated upwards, either to reach a second pay zone or extend higher into the pay zone or place injections well high in the reservoir, are ideal for drilling hot dry rock, geothermal injection and production of steam wells, also "J" type well for heavy oil production in combination with the hot rock drilling to inject into heavy oil and tar sand formations from the one bore hole. The wells can be deviated through any range of vectors and are ideal for pressure depleted zones. The system can drill radials of $2\frac{7}{8}$ " inside diameter (I.D.) well bores to the largest size well-bore.

Ultradeep Crude Technology (UCT)

Schematic drawing (figure 8) shows where a situation may be encountered, depth wise with either coiled tubing or conventional drill string where "J" type drilling may prove to be costly using present day tubing technology. In this situation, bore hole (7) will be cold water feed injector and bore hole (9) will be the steam production outlet line from the hot dry rocks, drilled from the top to intersect the HDR fractures. The bore hole (9) will run through the oil bearing reservoir. The casing will be cut just above the oil reservoir as shown at (10), by the milling or cutting method, the bore hole (9) will be side tracked into a horizontal bore hole (11), and the remainder of the production line (9), intersecting the HDR will then become bore hole (12), producing steam into the oil reservoir (4), the bore hole (8) is drilled horizontal into the oil reservoir and item (13) can be drilled in the "J" type configuration, well bore to be placed from underneath the reservoir.

Schematic drawing (figure 9) shows where a situation is encountered depth wise showing injector for cold water (item 7) drilled into fractured HDR reservoir and production extraction steam or hot water well (item 10) is drilled in the "S" type vertical or lateral from the surface and lateral or horizontal through the oil bearing foundation, then laterally or vertically down to intersect with the HDR reservoir. The well bore is then plugged back at item 13. Above the oil reservoir, more than one injector and/or producer can be drilled in each field if required with each well placed to a closed loop production system.

The schematic drawing shows figure 12 where high flow rates are required to be brought to the surface for separation and reinjection of the geofluid into the oil reservoir.

1. Shows doublet and trilateral well bores for high geofluid production rates.
2. Shows horizontal injection geofluid well bore to oil reservoir.
3. Shows cold water/geofluid injection (HDR) well.
4. Shows horizontal production geofluid well bore.
5. Shows oil reservoir.
6. Shows formation above oil reservoir.
7. Shows hot dry rock fractured reservoir.
9. Shows side track laterals.
10. Shows side track radials.
11. Shows horizontal/lateral well bore.

The schematic drawing shows figure 13 where a shaft/tunnels are drilled and horizontal twin wells are drilled with coiled tubing units. The top well bore is for water/steam geofluid injection, and the lower well bores for oil production, the HDR production well is placed in the mine shaft floor with wellhead flow lines connected to the horizontal geofluid injector well bores, and the cold water/geofluid surface injector is drilled from the surface to the HDR reservoir.

1. Shows surface HDR injector.
2. Shows formation.
3. Shows granite formation.
4. Shows oil reservoir.
5. Shows lateral injector.
6. Shows horizontal producer bores.
7. Shows horizontal injector geofluid bores.
8. Shows radial bores.
9. Shows radial bores.
10. Shows doublet production bores.
11. Shows lateral production bores.
12. Shows horizontal producer bores.
13. Shows horizontal injector geofluid bore.
14. Shows producer wellhead.
15. Shows mine shaft and tunnels.
16. Shows hot dry rock (HDR) reservoir.

Figure 1 shows vertical and extended reach, horizontal large diameter bore holes through three reservoir showing:-

1. Shows vertical well bore.
2. Shows horizontal well bore.
- 3,4 & 5. Shows oil or gas vertical fractured reservoirs.
6. Shows coiled tubing unit or drilling rig.
7. Shows earth foundation.
8. Shows "J" the well bores.

Figure 2 is "U" type drilling showing:-

1. Shows vertical well bore.
2. Shows vertical well bore (upwards).
3. Shows fractures from the well bore.
4. Shows horizontal well bore.
5. Shows earth foundation.
6. Shows 1 part in 10,000 granite foundation.

Figure 3 is showing "J" type drilling through two foundation reservoirs showing:-

1. Shows vertical well bore.
2. Shows horizontal well bore.
3. Shows upwards vertical well bore.
4. Shows reservoir.
5. Shows reservoir.
6. Shows earth foundation.
7. Shows horizontal well bore.

Figure 4 showing multiple horizontal bore holes from the one vertical well bore showing:-

1. Shows vertical well bore.
2. Shows horizontal well bores.
3. Shows "J" type well bores.
4. Shows horizontal well bores.
5. Shows reservoir.
6. Shows reservoir.
7. Shows earth foundation.

Figure 5 is "J" type drilling with a horizontal well bore from the "J" loop with vertical or horizontal production wells to the reservoir from the surface, the "J" type well is drilled vertical into hot dry rock foundation of one part 10,000 granite and fractured then up into the heavy oil reservoir from the horizontal into the vertical and then horizontally showing:-

1. Shows vertical well bore.
2. Shows horizontal well bore.
3. Shows upward vertical well bore.
4. Shows horizontal from the loop.
5. Shows fractures.
6. Shows granite one part in 10,000 formations.
7. Shows reservoir crude oil.
8. Shows earth foundation.
9. Shows horizontal production.
10. Shows vertical well bore.
11. Shows vertical well bore.
12. Shows "J" type well bore.

Figure 6 is showing "J" type drilling with multiple vertical "J" type loops from the horizontal under the oil reservoir with multiple vertical upward well bores into the oil reservoir showing:-

1. Shows vertical well bore.
2. Shows horizontal well bore.
3. Shows vertical upward "J" loop well bores.
4. Shows oil reservoir.
5. Shows earth foundations.
6. Shows earth foundations.

Figure 7 shows coiled tubing units drilling a vertical highly deviated well then horizontally in hot dry rocks then vertically upwards into the oil reservoir then horizontally from the "J" loop for maximum steam drive in the reservoir. The second coiled tubing unit is drilling production wells vertical then horizontal in the formation under the reservoir and vertically upwards into the reservoir then horizontally from the "J" type loop for maximum production by the use of the drainage system with large well bores showing:-

1. Shows coiled tubing unit, or drilling rig.
2. Shows formation.

3. Shows oil reservoir.
4. Shows formation.
5. Shows one in 10,000 granite formation.
6. Shows vertical bore.
7. Shows horizontal bore.
8. Shows vertical upward bore.
9. Shows horizontal bore from the "J" type loop.
10. Shows coiled tubing unit.
11. Shows vertical bore.
12. Shows horizontal bore.
13. Shows vertical upward bore.
14. Shows horizontal bore from the "J" type loop.
15. Shows fractures in granite (heat reservoir).

Figure 8 shows a diagrammatic view of the drill, and production of an oil reservoir and a hot dry rock steam injection method, showing:-

1. Shows coiled tubing unit or drilling rig.
2. Shows formation.
3. Shows formation.
4. Shows oil reservoir.
5. Shows granite formation.
6. Shows hydraulic fractures HDR reservoir.
7. Shows cold water injection water well.
8. Shows vertical and horizontal production well.
9. Shows vertical and horizontal production well.
10. Shows cut and milled casing from original bore hole intersecting HDR fracture.
11. Shows horizontal side track from (9).
12. Shows intersecting bore hole drilled from (9).
13. Shows vertical and "J" type production well bore.

Figure 9 shows a diagrammatic view of drilling and production of an oil reservoir and hot dry rock steam injection method, showing:-

1. Shows formation.
2. Shows formation.
3. Shows oil reservoir.
4. Shows formation.
5. Shows granite formation.
6. Shows HDR hydraulic fractures reservoir.

7. Shows cold water injection well.
8. Shows production oil well vertical "S" type.
9. Shows horizontal well bore from (8) "S" type.
10. Shows steam outlet bore to oil reservoir.
11. Shows steam outlet horizontal, lateral or vertical "S" type.
12. Shows steam outlet downward vertical from the horizontal or lateral.
13. Shows plug back or none-return valve or temperature recording equipment.

Figure 10 shows a diagrammatic view of the drilling and production of an oil reservoir and a hot dry rock steam injection method, showing:-

1. Shows drilling rig or coiled tubing unit.
2. Shows formation.
3. Shows oil bearing formation (reservoir).
4. Shows underlying formation.
5. Shows crystalline granite formation.
6. Shows fractured crystalline reservoir.
7. Shows large bore cold water inlet bore with injector.
8. Shows side track cold water injector bore.
9. Shows injecting steam production bore from HDR reservoir to oil reservoir.
10. Shows horizontal or lateral portion of (9).
11. Shows downward vertical or lateral bore of (10).
12. Shows downward vertical or lateral bore side track down from (10).
13. Shows side track from (9) to horizontal and lateral bore to HDR.
14. Shows downward vertical or lateral bore side track down from (13).
15. Shows plug back above formation or to use bore (9) for temperature recording or steam bleed (flash) of line, or production line.
16. Shows drilling rig or coiled tubing unit.

Figure 11 shows a diagrammatic view of the drilling and production of an oil reservoir and a hot dry rock steam injection method, showing:-

1. Shows vertical production bore hole.
- 2,3,4 & 5. Shows horizontal production screens.
6. Shows thermal set packer.
7. Shows special injector screen for steam.
8. Shows production injector base casing outlet.
9. Shows vertical cold water inlet injector casing.
10. Shows lateral inlet injector casing.

11. Shows oil bearing reservoir.
12. Shows fractured hot dry rock reservoir.
- 13&14. Shows two pairs of lateral and horizontal side track production bore holes.
15. Shows upper formation.
16. Shows crystalline granite formation.
- 17& 18. Shows well heads for tie-in to the closed loop production and separation units.

Advantages of the present invention

- (1) Allows the use of "J", "S", "U" and horizontal from the "J" loop wells to be drilled in hydro carbon, geothermal (HDR) type wells.
- (2) Allows the use of hot dry rocks (HDR) steam reservoirs to be fractured offshore for sea water injection and steam production into oil bearing formations for high enhanced oil recovery (EOR).
- (3) Allows light oil, heavy oil, tar sands, oil sands, oil shale to be produced onshore and offshore, with high pressure steam and other agents form subterranean crystalline rock formations (granite) that underly oil bearing formations.
- (4) Allows the oil to be produced by "J" type drilling in horizontal well bores, that are drilled through the oil bearing formation then drilled upward into the reservoir with large or small bore holes to drain the reservoir, and horizontal from the "J" loop also.
- (5) Allows hot dry rocks (HDR) to be used for oil recovery in any type of reservoir.
- (6) Allows a production method whereby the intersecting bore hole to a hot dry rock (HDR) reservoir, where the top portion of the well bore is cut away from the bottom portion by cutting or by milling, and where the top portion is sidetracked into the horizontal for use as production method in the oil reservoir and the bottom portion of the bore hole is used as a produced steam injection link into the oil reservoir, the top portion of the well bore may also if required be plugged back, or used for running, holding temperature recording equipment.
- (7) Allows the use of coiled tubing drilling for (HDR) hot dry rock geothermal drilling, also in "J", "S" and "U" type drilling in conjunction with oil HDR/EOR oil production.
- (8) Allows production under pressure at the well head by the use of a closed loop system between the HDR well and oil reservoir.

- (9) Allows the use of any directional and orientation controlled tools to be used to drill hot dry rock (HDR) geothermal energy type wells, to be used on conjunction with enhanced oil recovery methods.
- (10) Allows the use of carbon dioxide CO² or nitrogen to be used (injected) with hot water or steam for the gas phase in enhanced oil recovery with the ultradeep crude technology (UCT), hot dry rock (HDR), enhanced oil recovery (EOR) method, or on its own.
- (11) Allows the use of HDR steam/hot water to be used for EOR methods when the geofluid is returned to the surface in conjunction with the drilling of UCT methods.
- (12) Allows the use of horizontals, laterals/doublets/triplets and radials to be used on HDR/EOR/UCT injectors and producers.
- (13) Allows the use of carbon dioxide CO² to be used in the super critical condition to stimulate oil recovery through the use of HDR/EOR.
- (14) Allows the use of carbon dioxide CO² to be used in the super critical condition to clean drilling cuttings at the surface.
- (15) Allows the use of water/steam, light fraction hydrocarbons and/or gas, i.e. CO₂ or N, all in solution at pressure to aid petroleum recovery in light, medium or heavy crude oils, when used in the hot dry rock (HDR), enhanced oil recovery (EOR) method, in a closed loop system, to be used underground or at the surface for reinjection to the reservoir.
- (16) Allows the ultradeep crude technology (UCT) method to be used in large bore holes, shafts or tunnels with coiled tubing drilling into the reservoir with twin horizontal bores and radials for maximum oil recovery, with a steam wellhead in the mine shaft.
- (17) Allows the use of propants in the form of pellets made from ceramics high temperature elastomer compounds above 350°C to keep the HDR reservoir fractures open.
- (18) Allows the use of HDR/UCT geofluid or hot water/steam to move paraffins and asphaltines. The heavy hydrocarbons that settle out and clog production casings/tubings and pipe lines, either by reservoir produced HDR/UCT geofluid, or by bring the geofluid to the surface for reinjection into the well before or pipeline to clear them.
- (19) Allows the use of produced geofluid (hot H₂O/steam, light fraction hydrocarbons and/or gas) to be used to reduce the viscosity of any heavy, medium or light oil underground or at the surface.
- (20) Allows the use of an expansion chamber (polished bore) receptacle, to receive super heated hot water through large bore injection casing, to flash to steam by choke outlet tubes through the base of the receptacle unit.

(21) Allows the use of milled tooth drilling bits (PDC) polycrystalline diamond compacts inserts and/or diamond inserts type drilling bits (heads) with ultra/high pressure flow nozzles/inserts. The ultra/high pressure fluid can be supplied from direct surface equipment, to the bit down-hole or converted to ultra/high pressure by other means, in the drilling bit (head) body downhole, to cut the rock/formation prior to the crushing/cutting action with the drilling head, to be used for enhanced oil recovery (EOR) methods in conjunction with hot dry rock (HDR) method ultradeep crude technology (UCT).

High Flow Rates

Figure 14 showing ideal well injection and production geometry for high production flow rates with single injector well and twin trilateral production wells., allows for high flow rates due to in-situ two-way (sides) growth stress in the HDR reservoir e.g. 2,000 GPM injector and 2,000 GPM producing through trilateral production system

1. Shows injection well.
2. Shows production well to surface or downhole packer for reservoir heat input (geofluid).
3. Show production well to surface or downhole packer for reservoir heat input (geofluid).
4. Shows oil geofluid production well.
5. Shows oil geofluid production well.
6. Shows trilateral production well geometry.
7. Shows trilateral production well geometry.
8. Shows horizontal production steam/hot water/gas production HDR well (geofluid).
9. Shows horizontal production steam/hot water/gas production HDR well (geofluid).
10. Shows oil formation.
11. Shows hot dry rock (HDR) fractured reservoir.
12. Shows hot dry rocks.
13. Shows overburden formation.
14. Shows ground surface.

Near Critical, Critical and Super-Critical Fluid Recovery Method

Extraction of soluble organic matter from sedimentary rocks by near critical, critical and super-critical gases including N₂ with light fraction hydrocarbons and hot water/steam.

Adding CO₂ alone to hot water/steam at pressure will substantially improve the oil (hydrocarbons) recovery rate as the CO₂ will dissolve in the oil phase and cause the oil to swell and lower the gravity with hot water/steam drive, all in a closed loop injection and production system, to provide added volume for displacement of oil from the hydrocarbon strata.

A small increase in pressure induces a large increase of density, the viscosity of super-critical fluids is lower than that of liquids, the diffusion coefficient is about one hundred times greater for super-critical than for liquid.

The temperature at which production to the hot dry rocks for injection in to the hydrocarbon reservoir is important, at low pressure the fluid has properties of a gas which means that for an increase of temperature the solubility decreases at high pressure, the fluid has properties of a liquid and an increase of temperature results in an increase of solubility, hot water/steam, light fraction hydrocarbons and near critical carbon dioxide CO₂ all in a gaseous slurry will provide an ideal enhanced oil recovery (EOR) sweep fluid for a pressurised closed loop production system (UCT-EOR-HDR).

Adjustable reamer/stabiliser

One aspect of the present invention provides an adjustable reamer/stabiliser tool. This tool is a valuable aid in the drilling of multidirectional wells, such as those required to implement the first part of the invention. Reamers and stabilisers are conventional drilling tools but the tools according to this aspect of the present invention are structurally distinct and advantageous compared with the known tools.

One distinctive feature of the reamer/stabiliser of the present invention is that it is adjustable. That is, the radial extent of the tool is capable of fine adjustment - to suit the particular diameter of the well bore at any particular location. Such a feature is extremely advantageous when one wishes to drill multidirectional wells.

The reamer/stabiliser is referred to as such since it can be used either as a reamer or as a stabiliser, according to the operative blades selected for fitting to the body of the tool. An embodiment of the tool is shown in figure 16. A cross-sectional view, taken across the diameter of the tool and showing the tool body and operative blades, is shown in figure 20. Figures 17, 18 and 19 show variations of the operative blades which can be fitted to the body of the tool. The operative blades shown in figures 16 and 20 are stabiliser blades whereas those shown in figures 17, 18 and 19 are reamer blades. The tool is inserted at the required location in the down hole well string.

With reference to figure 16, the tool body 1 is connected to the drill string at one end by the pin connection 35 and at the other end by a box connection 36. Box connection 36 is provided in an end locator sub-assembly 2 attached to the tool body 1. The operative blades 13 are carried by the main tool body and are, of course, arranged for radial movement with respect to the tool body. As shown, the blades have a generally trapezium shaped cross section with the shorter of the parallel sides being inner most. The inclined edges/surfaces rest on respective angle blocks 11,12. As indicated in figure 20, four blades are located around the circumference of the tool and each is seated in a respective guide slot 46.

Each blade guide slot has a fixed angle block 12 at the end of the slot adjacent the pin connector 35 and a moveable, or thrust, angle block 11 at the other end of the slot. The angle blocks each have an inclined surface, on which the respective inclined surfaces of the blade 13 rest. The thrust angle block is capable of movement in the slot in the longitudinal direction of the tool body. It will be readily appreciated that such

movement changes the distance between the angle blocks 11 and 12 and thus causes the inclined surfaces of the blade 13 to slide over the inclined surfaces of the angle blocks. This has the result of moving the blades radially with respect to the tool body. The blades are retained in the tool body by means of pivotal links 15 by which they are attached to the angle blocks.

Movement of the thrust angle blocks, and thus movement of the blades, is achieved by respective telemetry control units, eg 62. Each telemetry control unit comprises a piston 17 connected to the respective thrust angle block by a connecting rod 22. A return spring 29 acts to return the angle block to the position in which the respective blade is fully retracted. Movement of the piston 17, and hence block 11 and blade 13, is controlled by an operator above ground by means of telemetry.

In the illustrated embodiment, movement of piston 17 is achieved in the following manner. Acting on the face of the piston 17 is a toggle rod 23. The toggle rod 23 is coupled to a tooth shaped latch 24, which interacts with two latch flats 26 and 27 which are of different longitudinal extent. The flats abut a fluid pressure piston 28. Piston 28 moves under pressure of fluid in chamber 7 and control of component 8. Component 8 is a conventional unit which is operated by pressure pulses induced in the hydraulic fluid contained in the central bore of the drill string/tool body. The pressure pulse is electronically analysed and inlet/outlet valves to chamber 7 actuated in accordance with predetermined pulse formats. The pressure pulses are controlled/initiated above ground to control operation of the tool downhole.

A device is provided within the tool in order to indicate the state of expansion or contraction (radial position) of the blades to an operator above ground. This device comprises a venturi flow dart 37. Movement of the thrust angle blocks affect flow past the dart and the change in flow rate is detectable above ground.

The adjustable rotary reamer/stabiliser is an ideal tool to be used in all types of multi-directional drilling operations, the assembly uses adjustable integral blades either straight or helix with barrel roller cutters or balls to reduce friction and drag down-hole from the accumulator unit fitted to the top end of the reamer/stabiliser body.

The system is controlled from the surface by hydraulic pressure which actuates the telemetry unit controllers (TUC's) fitted into the side pockets of the body, either three or four, subject to the configuration of the blades, which is controlled by hydraulic pressure supplied by the accumulator, when the drilling assembly is picked up from the bottom of the well allowing the weight of the assembly to activate the

downward force of the accumulator, to exert differential pressure across the faces of the three or four pistons, allowing the pistons to travel forward to activate the toggle and latch system within the telemetry unit controllers unit (TUC's).

With the toggle and latch in the back position the reamer/stabiliser blades are in the minimum gauge position, and when the toggle and latch are in the forward position the reamer/stabiliser blades are in the full gauge position.

The action of the thrust piston travelling forward by the differential pressure across the tool allows the drive angle block to travel forward, pushing the angle faces of the helix type, or straight blade, against the angled face of the fixed forward block, allowing the blade to travel outwards in a controlled manner by the two connecting roller links which are held in place by the roller pins. When pressure is exerted on to the fluid pressure piston next time, the toggle and latch is released into the second position, this allows the spring pressure on the back seat of the thrust piston to pull the blade back into the closed position in a reverse blade action. The approximate time to operate the valve in the forward or closed position is the velocity of pressure transmission and can be considered instantaneous in the order of 1470 metres/second or 4850 feet/second when using typical hydraulic oil. The use of drilling fluid would slightly increase this time. Using either fluid, opening and closing of the valve will be very fast.

The advantage of this type of actuation is that it is operated from the minimum gauge to the maximum gauge position by the method known as the hydraulic toggle and latch, operated by the weight set accumulator by over pull on the drill string, this is particularly useful in high torque situations. The other advantage of this type of tool is that it can be used as a near bit or string type of reamer/stabiliser. It is also important for the driller on the rig floor to know when the tool has been activated, this is done by a flow indicator dart fixed to the internal venturi sleeve, fixed inside the venturi sleeve is a sliding venturi piston with seals, either three or four retaining pin locators depending on the number of blades used within the body of the reamer/stabiliser, the retaining pins are then secured into the body of the thrust angle block allowing the sliding venturi piston to travel forward with the thrust angle block by three or four oblong slide portscut through the body of the stabiliser and the internal venturi sleeve allowing for the locator pins to travel back and forth by the movement of the thrust angle block and the sliding venturi piston and allowing restricted flow through the venturi piston by the flow indicator dart.

In the activated locked position, ie maximum gauge, the flow indicator dart will restrict the flow through the sliding venturi piston that will be in the forward position, this will give a 200psi flow restriction when the tool is in the full gauge locked position and the head of the flow indicator dart is inside the venturi piston and there will be a

corresponding 200psi pressure drop on the drillers surface pressure gauge, indicating to the driller which position the tool is in, ie. minimum or maximum gauge of the reamer/stabiliser.

The body of the reamer/stabiliser is grooved either in the straight configuration for straight blades or spiral grooved for the helix shaped blade. The blades are shaped to the diameter of the body in a convex outer shape and a concave lower shape with parallel sides.

The blade openings in the reamer/stabiliser body are milled out, either three or four depending on configuration, to allow a good fit of the reamer/stabiliser blade with the two angled blocks. The two end faces of the reamer/stabiliser are machined to matching angles to correspond with the thrust angle blocks. In the box end of the main reamer/stabiliser body three or four cylinder retaining ports are drilled to house the above mentioned telemetry unit controllers in the body housing toggle and latch, these are retained in position by three or four end blanking plugs. Full circumference flow ports are machined into the main reamer/stabiliser body to allow full flow differential pressure across the three or four piston faces.

The bore of the main reamer/stabiliser body is bored out to a pre-set depth larger than the main bore to accommodate the main internal venturi sleeve that houses the flow indicator dart and venturi piston. This is secured in position by an end sub with a box connection at one end and a pin connection at the other which fits into the main reamer/stabiliser body. The other end of the reamer/stabiliser body can be either a pin or box connection by is shown in the drawing as a pin connection. The end sub also overlaps the end retaining seal plugs securing the telemetry unit controller in place, this safeguards against the loss of any components down-hole.

The reamer/stabiliser blades are held in position within the angle blocks by two ball type forged links and held in place in the angle blocks and blade by four roller pins, completely secured within the reamer/stabiliser body with no possibility of losing any components down-hole.

The thrust piston within the telemetry unit controller is threaded into the thrust angle block securing it within the main reamer/stabiliser body. The fixed angle block is held in place by round locator pins fitted to the underside of the angle block. The bottom ends of the pins are milled halfway across their diameter. They are then fitted through pre-drilled holes in the bottom of the blade recess through the main reamer/stabiliser body into the main bore, this allows the internal venturi sleeve to locate itself into the half round milled out windows locking the fixed angle blocks into position. This then allows forward motion when the valve is activated pushing the thrust piston, whereby the thrust angle block travels forward opening the blades from minimum gauge position to maximum gauge position, travel of the blades for

maximum gauge, ie. increasing diameter, is controlled by the allowance given to the forged links within the angle blocks and main body.

The adjacent faces of the two angle blocks and blade are self adjustable to the wear occurring within the connecting roller links and the inner link housing of the two blocks and blade. The pattern of the reamer/stabiliser blades can be either or angled roller type reamer cutters or spherical balls encapsulated within a housing and secured within boreholes in the reamer/stabiliser blade or, ideally, angled cross type barrel roller cutters of various types that are secured within milled out housings within the reamer/stabiliser blade by roller bearing pins fitted through the sides of the reamer/stabiliser blade. The total assembly is encapsulated within the blade by the main reamer/stabiliser body. This total design allows for no component part to work loose through vibration, therefore no component part can be lost in the hole.

This adjustable angle rotary roller reamer/stabiliser allows true vertical, lateral and horizontal drilling control, free from excessive torque and drag experienced in highly deviated lateral and horizontal wells.

It should also be noted that either one or two reamer/stabilisers can be used eccentrically when employed with drilling mud motors for fine tuning the directional control by use of the predetermined settings of the return springs of the hydraulic latch valves, allowing for one blade to remain in the closed position while the other two are open, this allows the stabiliser to lay within the well bore eccentrically north facing while the other stabiliser lies within the well bore eccentrically south facing, ie. one up one down. This allows the down-hole adjustable stabilisers to be free from torque and drag in this mode. The roller action and honing of the well bore allows the drill string to be pushed with ease with weight on the bit, allowing for faster rates of penetration.

The new concept of the adjustable rotary roller reamer/stabiliser which can be activated and de-activated down-hole by a simple pressure change through the telemetry unit controller, will change the face of directional drilling techniques. In the past, the driller would have to pull out of the hole (trip) to change the stabilisers gauge or to ream the hole. The use of a single adjustable stabiliser might provide a semi-steerable system. The present invention allows for the use of two making it a fully steerable system by altering the gauge between the two positions and will be able to simplify, and easily follow the planned curvature of the well path, giving very accurate trajectory control.

The configuration of the adjustable angle rotary roller reamer/stabiliser in its various forms can be substituted with other types of blades as shown in figures 17, 18 and 19.

It has long been recognised in the drilling industry that angle type rotary reamers are ideal for full gauge hole reaming and drill stabilisation, and is ideal for

directional drilling control, but the conventional reams (which have on many occasions fallen apart down-hole) this together with the enormous cost of fishing for broken parts left down-hole. Repair and re-dressing of stabilisers, reamers etc. make this invention highly desirable for all types of drilling control in high extended reach lateral and horizontal wells, and in particular with the new laws of the non-use of oil base muds, when water base muds are used this reduces the torque and drag on the drilling assembly.

This invention has been developed as a near bit integral and string adjustable bladed rotational angle roller reamer/stabiliser and will radically change the current stabiliser market. This is due to the wall contact and full roller driving action of the bottom barrel roller that stops the old slide drilling action of the bottom hole assembly. Due to the unique method of continual rolling of the reamer/stabiliser down-hole, allowing the drill bit to have a continual cutting action in the well bore face, cutting out bit walk, and making hole much faster than the old slide method. By altering the gauge of the reamer/stabiliser it is possible to make the hole build hold or drop angle, as required, the basis of the reamer/stabiliser tool allows the angle barrel rollers, 15 or 20 of them, giving full gauge stabilisation, correct positioning of the drill string in the well bore which is rotating on barrel rollers, with full width or bore roller movement, allowing the tool to roll down the well bore eliminating torque and drag, enhances stabilisation, stopping side forces on the drill bit and thereby cutting out bit walk by rolling across the full face of the wall rather than climb up the side (unlike normal reamer/stabiliser) allowing increased ability for bits to drill in the direction that they are aimed. The diameter of the reamer/stabiliser is remotely controlled from the surface on the rig floor, by lifting the drilling assembly from the bottom hole position allowing the accumulator to activate the telemetry unit controllers (TUC's)

Figure 16 shows a radial cross-section of an adjustable rotary reamer/stabiliser.

1. The main reamer/stabiliser body.
2. Shows end locator sub.
3. Shows internal venturi sleeve
4. Shows venturi sleeve seal top.
5. Shows venturi sleeve seal bottom.
6. Shows sliding venturi piston.
7. Shows fluid chamber.
8. Shows piston accumulator lift sub.
9. Shows accumulator flow ports.
10. Shows slide pins.
11. Shows thrust angle block
12. Shows fixed angle block.

13. Shows reamer blades.
14. Shows milled window retainer angle block pins.
15. Shows forged links.
16. Shows bearing pins
17. Shows valve assembly.
18. Shows valve retaining plug and piston stop.
19. Shows valve chamber.
20. Shows full flow differential port.
21. Shows internal venturi sleeve ports.
22. Shows thrust piston.
23. Shows ball toggle rod.
24. Shows tooth shaped latch.
25. Shows valve body cylinder.
26. Shows top flat on valve cylinder.
27. Shows bottom flat on valve cylinder.
28. Shows fluid pressure piston.
29. Shows pressure spring.
30. Shows lift sub. key anti-rotation.
31. Shows piston seals.
32. Shows housing for reamer/stabiliser blades.
33. Shows bore holes for 14.
34. Shows threaded connection on thrust piston to thrust angle block.
35. Shows pin connection.
36. Shows box connection.
37. Shows flow ports in flow indicator darts.
38. Shows box connection.
39. Shows key way main body.
40. Shows opposing angle faces.
41. Shows bearing link housing.
42. Shows spiral flow cut.
43. Shows seals/sub to piston lift sub.
44. Shows equalising port.
45. Shows bore.
46. Shows reamer blade housing.
47. Shows restricted flow in full gauge position.
48. Shows elongated guide hole for eccentric blades (if required).

Figure 17 shows a radial cross-section of an adjustable reamer/stabiliser blade with spherical cutter balls.

- 49. Shows blade body.
- 50. Shows seal cups.
- 51. Shows locking pins.
- 52. Shows spherical balls.

Figure 18 shows a radial cross-section of a reamer/stabiliser blade with cross cutting barrel rollers.

- 53. Shows blade body.
- 54. Shows vertical rollers.
- 55. Shows guide rod.
- 56. Shows bushings or bearings.

Figure 19 shows a radial cross-section of a reamer/stabiliser blade with vertical cutter rollers.

- 57. Shows blade body.
- 58. Shows barrel rollers.
- 59. Shows guide pins.
- 60. Shows bushings or bearings.

Figure 20 shows an axial cross-section of a reamer/stabiliser body.

- 61. Shows stabiliser body
- 62. Shows differential flow ports and TCU.
- 63. Shows full return flow grooves.
- 64. Shows blade body.
- 65. Shows full flow bore.
- 66. Shows reamer/stabiliser body.

Thrust callipers

Another aspect of the present invention provides a thrust calliper tool. This tool is a valuable aid in the drilling of multidirectional wells, such as those required to implement the first part of the invention. An embodiment of the tool is shown in figure 21.

With reference to figure 21, the tool body 41 is connected to the drill string at one end by the pin connection 31 and at the other end by a box connection 34. Bore gripper blades 24 are carried by the main tool body and are, of course, arranged for radial movement with respect to the tool body. As shown, the blades have a generally trapezium shaped cross section with the shorter of the parallel sides being inner most. The inclined edges/surfaces rest on respective angle blocks 23,29. As indicated in figure 22, four blades are located around the circumference of the tool and each is seated in a respective guide slot 25.

Each blade guide slot has a fixed angle block 29 at the end of the slot adjacent the pin connector 31 and a moveable, or thrust, angle block 23 at the other end of the slot. The angle blocks each have an inclined surface, on which the respective inclined surfaces of the blade 24 rest. The thrust angle block is capable of movement in the slot in the longitudinal direction of the tool body. It will be readily appreciated that such movement changes the distance between the angle blocks 23 and 29 and thus causes the inclined surfaces of the blade 24 to slide over the inclined surfaces of the angle blocks. This has the result of moving the blades radially with respect to the tool body. The blades are retained in the tool body by means of pivotal links 26 by which they are attached to the angle blocks.

Movement of the thrust angle blocks, and thus movement of the blades, is achieved by respective telemetry control units, eg 2. Each telemetry control unit comprises a piston 18 connected to the respective thrust angle block by a connecting rod. A return spring 19 acts to return the angle block to the position in which the respective blade is fully retracted. Movement of the piston 18, and hence block 23 and blade 24, is controlled by an operator above ground by means of telemetry.

The thrust calliper, as its name implies, provides thrust as well as calliper action. Thus, with the calliper blades gripping the well bore, the central portion of the tool can be thrust forward so as to exert forward thrust on a drill bit attached to the tool via pin

connector 31. The mechanism for achieving this thrust is located longitudinally behind the gripper blades 24 (to the left in figure 21) and is shown in more detail in figure 25. Figure 25 also shows the detail of the telemetry control units used to control the movement of the calliper gripper blades 24.

With reference to figure 25, the mechanism for controlling movement of the calliper gripper blades is essentially shown in the upper half of the figure and the mechanism for forward thrust of the tool is essentially shown in the lower half of the figure. However, it will be apparent from the figure that the two mechanisms are interconnected such that forward thrust occurs when the gripper blades are extended, gripping the bore, when forward thrust occurs and that the blades are released after forward thrust has occurred. Typically two of the thrust calliper tools will be used together in a drill string. Thus, one tool grips the bore and thrusts the entire drill string forward. Subsequently the second tool grips the bore and thrusts the entire drill string forward. The first tool is now in position again to grip the bore and thrust forward, and so the sequence is repeated. A third thrust calliper tool may also be used in the drill string. For example, the calliper blades of the third tool can be used to grip the inner cylindrical surface of a bore liner. Thus, the tool can be used to pull a liner along the bore behind the drill bit.

Forward thrust is achieved by fluid pressure in chamber 40. As the tool moves forward, actuator 61 moves to the end of its travel within its chamber and further forward movement of the tool causes cam piston 64 to move radially inwards towards the central longitudinal axis of the tool. This movement of the cam piston operates control units 1 and 2. These control units have a toggle and latch mechanism and control the flow of hydraulic fluid into chambers 40 and 33 respectively.

The two control units 50 and 53 which control movement of the calliper gripper blades are of essentially the same design as control units 1 and 2. The detail of one of these control units is shown in figure 26.

Hydraulic fluid within the drill string is used to operate the various mechanisms. After use the fluid is dumped to the annulus between the drill string and the well bore.

The caliper thrust units hereafter referred to as CTU's consists of a caliper body employing the same trust angle blocks and fixed angle blocks together with centre angle blades as described in relation to the adjustable rotary roller reamer/stabiliser.

The caliper system consists of the main caliper body with either three (3) or four (4) oblong caliper housings machined into the caliper body, fitted into each caliper housing are the two (2) thrust angle blocks and fixed angle blocks together with the caliper blade well bore gripper segments, these are activated by a caliper thrust piston which is controlled by hydraulic pressure feed from the rear thrust collar valve control sub which is controlled by the forward thrust and return valve system within the centre valve assembly, this caliper thrust unit assembly simultaneously applies forward thrust to the hydraulic drill collar thrust piston exerting a forward motion on to three (3) or four (4) control pistons on the thrust angle caliper blocks which in turn forces out the caliper blades locking them into the well bore, and the return action of the caliper blade is again simultaneous, when no. one (1) telemetry unit controller opens and no. three (3) telemetry unit controller closes the no. four (4) telemetry unit controller opens and the no. two (2) telemetry unit controller closes, these valves are sequenced by the cams and camshafts at the end of each thrust and return travel of the hydraulic drill collar (piston), this then equates to the caliper segments locked into the well bore and the caliper thrust units travelling forward, adding weight to the forward drilling assembly and drill bit, simultaneously behind the front caliper the rear caliper performs the closing and retracting sequence whereby valve no. seven (7) is open, valve no. five (5) is closed, valve no. six (6) is open and valve no. eight (8) is closed, this allows fluid pressure to be exerted on to the centre valve assembly (CTU) forcing the caliper body, which is now in the closed position, by the opening of valve no. six (6) allowing the return spring to retract the caliper blades from the locked to the retracted position, this places the back caliper assembly of the (CTU) in the return position ready for the next drilling thrust caliper sequence, this is a continual opening and closing movement of the telemetry unit controller and a thrusting and retracting of the (CTU) by the sequencing of the telemetry unit controller, as described more fully in relation to the adjustable reamer/stabiliser, whereby valves 1, 5, 4 and 8 will always be in one position and valves 2, 3, 6 and 7 will be in the opposite position by a pre-determined change in flow pressure, eg. 400 psi above drilling pressure, the pressure pulse then operates the toggle/latch assembly on no's nine (9) and ten (10) telemetry unit controllers, then shutting down the pumps to close both front and rear calipers (CTU) for tripping the drilling assembly out or into the well. The length of stroke of the (CTU) will be recorded on the measurement while drilling system (MWD), the information is fed to a computer when the maximum travel is obtained by the (CTU) recording complete depth record. The cams and camshaft allows the valve sequences to be changed one set of calipers is retracted while the other set is locked to the well bore and simultaneously the (CTU) is thrust forward from the locked calipers adding weight to the drilling assembly and drill bit, while the other set of calipers is retracting.

The operational principle of the tool is by differential pressure across the tool, when each pair of valves are open to allow differential pressure into one side of the main valve body cylinder.

The telemetry unit controllers as used in the adjustable rotary roller reamer/stabiliser and thrust caliper units can also be used as a dump valve system as shown, which are activated at a pre-determined spring pressure set above the spring pressure of the other telemetry unit controllers, both of the dump valves will operate as a pair, either both in the closed position, allowing drilling fluid to leave chamber and feed port, which feeds the chamber allowing the piston to return to the unlocked position, allowing the calipers to be retracted, this sequence is simultaneous on both front and rear calipers to allow tripping in and out of the well. To allow the calipers to continually thrust forward, adding weight to the drill bit, at the end of the hydraulic drill collar travel, allowing the caliper to return to the start position ready for the next thrust operation, this can be achieved by hydro mechanical actuation on the first and second caliper, whereby one caliper is locked into the well bore by the actuation of the angle blocks exerting pressure the gripper inserts which are forced out under pressure locking the caliper to the well bore. Hydraulic pressure is applied to the rear chamber applying force to the centre valve body which is an integral part of the hydraulic drill collar, thrusting forward and adding weight to the drill bit, when it reaches the end of its travel within the chamber it strikes the cam striker face on the camshaft end. To operate the twin caliper drilling system for running the caliper in the well bore, start the mud pumps and apply the pre-determined drilling fluid pressure, above the normal drilling pressure, for a set amount of time, then pull back on the pressure to lock the two telemetry unit controller dump valves (figure 25 items 50 and 53) open, ie. telemetry unit controller valve (figure 25) open position in hydraulic drill collar (figure 25 item 53) in cylinder body allowing fluid pressure through ports (figure 25 items 13 and 15) to operate the second dump valve (figure 25 item 53) in the open position in the hydraulic caliper body allowing fluid to leave through port (16) so that the two calipers are in the closed position. To start drilling increase pump pressure to pre-determined telemetry unit controller dump valve rate for the present number of seconds and then pull back on pump pressure to normal drilling fluid pressure, this will close the two (2) dump valves (figure 25 items 50 and 53) as shown allowing simultaneously for drilling fluid to enter through inlet flow port (figure 25 item 9) with the valve (1) in the open position, this allows fluid to enter chamber, simultaneously entering the caliper segment flow ports (17) to thrust the caliper segments outward, either 3 or 4 segments depending on the amount used and the pressure thrust pistons (figure 25 item 19=8) locking the caliper segments to the well bore holding the caliper body secure within the well bore, at the same time as this is happening the spool valve

(figure 25 item 69) in the front chamber is closing, item 3 to stop fluid entering the chamber item 40, valve item 1 is opening to allow fluid to enter chamber item 40 to allow the hydraulic drill collar (piston) item 30 to thrust forward through the locked caliper, the four hydro mechanical spool and telemetry unit controllers are all simultaneously operated with the internal cylinder operating mechanism by the spool valve piston item 69 and camshaft item 61 relief ports and return side spool valves, the spool valve item 4 is open to allow fluid out of chamber item 33 and the telemetry unit controller item 2 is closed to stop fluid entering chamber item 33 when the hydraulic drill collar piston item 30 reaches the end of its travel in the caliper body chamber item 33, the spool control valve item 69 is activated in the forward position and opens exhaust spool valve item 3 to allow fluid to leave exhaust port item 12 and close port item 11 simultaneously operating the camshaft and striker piston item 61 to activate the cam item 64 to open the telemetry unit controller item 2 to allow fluid to enter chamber item 33 and close the telemetry unit controller item 1 to stop fluid entering chamber item 40 to return the hydraulic drill collar back to the start thrust position with the calipers in the closed position, when one caliper is in the operating thrust mode, the other one is in the reverse order returning back along the hydraulic drill collar as the forward drilling assembly is thrusting forward adding weight to the drilling assembly and drill bit.

Use of the twin caliper eccentric system with eccentric stabilisers will allow the measurement while drilling system (MWD) to be placed as close as possible to the drill bit allowing complete trajectory control when used in the eccentric blade setting, it allows complete directional control with the use of two (2) adjustable reamer/stabiliser, one near bit and the other first string.

Depending on how the telemetry unit controllers (TUC's) valves are sequenced before running in to the well. The pair of reamer/stabiliser can be full gauge together or under-gauge or one under-gauge and the other full gauge, allowing full directional control, for coiled tubing or conventional drill string drilling. It is also possible to set the blades in the reamer/stabiliser in the eccentric positions within the tool body of the rear one and orientation of this is performed from the rig floor allowing ideal curvature in directional control when used with mud motors, this can be used with twin calipers to hold eccentricity of the caliper that is returning back to the start position, this method is ideal for complete controlled trajectory drilling giving a much smoother (low-micro) dog-leg well bore precisely along a planned 3D path, reducing torque and drag allowing extra long extended reach drilling, and reducing drilling and well costs dramatically. The twin caliper system fitted to either rotary drill pipe or coiled tubing allows thrust to the drilling assembly, the trajectory control unit for bit angle face and orientation unit may also be used if required, the adjustable rotary roller

reamer/stabiliser gives a cutting and rolling action in the well bore reducing torque and drag and stopping slide drilling the complete system is operated on differential hydraulic pressure with all adjustments to the drilling assembly being performed down-hole purely by an increase in pressure by weight set control from the rig floor by the weight set accumulator fitted above the reamer/stabiliser and the trajectory control unit with orientation unit, by an increase in drilling pressure, the caliper system is working fully automatically with normal drilling pressure and can only be stopped by the increase of a pre-determined pressure to allow the four (4) telemetry unit controller dump valves to open, allowing tripping in and out of the well bore with the drill string. The drilling assembly continues closed and mud pressure maintained the drilling assembly continues drilling and thrusting, making hole again, with the four (4) telemetry unit controller valves fitted in the thrust caliper valve block assembly on each caliper.

A pair of thrust caliper units can also be fitted to the end of coiled tubing with drill pipe fitted to the thrust side between the drilling motor and trajectory control unit (TCU).

To adjust the rotary roller reamer/stabiliser just lift the drilling assembly to operate the four (4) telemetry unit controller valves in the valve body of the adjustable rotary roller reamer/stabiliser, again to release. Pressure increases apply to the operation of the trajectory control unit by the telemetry unit controller valves fitted into the body of the trajectory control unit and orientation unit, operation depends on the depth but from a 10,000 ft well time is approximately 2.4 seconds, each set of valves require separate operation with different pre-determined pressures set above normal drilling pressure.

Figure 21 shows a radial cross-section of a caliper thrust unit showing:-

1. Shows front caliper inlet piston telemetry unit controller thrust.
2. Shows front caliper inlet piston telemetry unit controller return.
3. Shows front caliper outlet valve control spool thrust.
4. Shows front caliper outlet valve control spool return.
5. Shows rear caliper inlet piston telemetry unit controller thrust (not shown on drawing, reference only).
6. Shows rear caliper inlet piston telemetry unit controller return (not shown on drawing, reference only).
7. Shows rear caliper outlet valve control spool thrust (not shown on drawing, reference only).
8. Shows rear caliper outlet valve control spool return (not shown on drawing, reference only).
9. Shows thrust inlet port.

10. Shows return inlet port.
11. Shows outlet port return.
12. Shows outlet port thrust.
13. Shows valve operating ports to the TUC dump valve piston assembly.
14. Shows valve operating ports to the TUC dump valve cylinder assembly.
15. Shows valve flow ports to the TUC dump valve piston.
16. Shows valve flow ports to the TUC dump valve cylinder.
17. Shows flow port to caliper thrust piston.
18. Shows caliper thrust piston.
19. Shows caliper piston return spring.
20. Shows fluid chamber return side.
21. Shows seals hydraulic drill collar to cylinder body.
22. Shows end plugs.
23. Shows angle thrust caliper block.
24. Shows caliper blade.
25. Shows caliper housing.
26. Shows forged caliper links.
27. Shows bearing link pins.
28. Shows forged link housing.
29. Shows fixed angle caliper block.
30. Shows hydraulic drill collar (piston) and valve assembly.
31. Shows pin connection.
32. Shows caliper body hydraulic drill collar bore.
33. Shows caliper body cylinder return dump valve port (hydraulic drill collar).
34. Shows box connection.
35. Shows telemetry unit controller bore.
36. Shows caliper body control sub (cylinder).
37. Shows centre valve assembly of hydraulic drill collar (piston).
38. Shows back caliper body valve sub.
39. Shows pin and box connection caliper body.
40. Shows fluid chamber thrust side.
41. Shows caliper body.
42. Shows seals cylinder for spool valve.
43. Shows valve hydraulic thrust (piston) cylinder.
44. Shows angle block lock pins.
45. Shows hydraulic drill collar torque rod and spool valve.
46. Shows seals cam shaft.

47. Shows seals in cylinder body.
48. Shows seals hydraulic drill collar piston assembly.
49. Shows seals spool valve piston.
50. Shows outer dump valve (valve body).
51. Shows thread on piston hydraulic drill collar.
52. Shows slide pads and seals.
53. Shows inner dump valve (cylinder casing.)
54. Shows flow pathways.
55. Shows cam/piston valve.
56. Shows cam/piston valve.
57. Shows bore of hydraulic drill collar.
58. Shows thread for striker piston cylinder.
59. Shows cam shaft cylinder body (striker) (rear).
60. Shows cam shaft cylinder body (striker) (front).
61. Shows cam shaft valve body and striker piston.
62. Shows actuator cam cylinder (rear).
63. Shows actuator cam cylinder (front).
64. Shows actuator cam piston.
65. Shows camshaft striker piston cylinder.
66. Shows spool control valve connection.
67. Shows spool valve locator.
68. Shows stirker plates valve control spool.
69. Shows spool valve piston.
70. Shows thread on thrust rod.

Figure 22 is an axial cross-section of the caliper thrust unit showing:-

1. Shows thrust caliper body.
2. Shows thrust pistons (four).
3. Shows hydraulic drill collar.
4. Shows hydraulic drill collar bore.
5. Shows inside diameter (I/D) of well bore.
6. Shows fluid pathways.
7. Shows caliper gripper segments (blades).
8. Shows blades closed.

Figure 23 is an axial cross-section of the caliper thrust unit caliper body and hydraulic drill collar piston valve block assembly showing:-

1. Shows caliper body.
2. Shows hydraulic drill collar piston valve block assembly.
3. Shows telemetry unit controller s(two).

4. Shows flow ports to caliper pistons.
5. Shows torque rod and spool valve.
6. Shows dump valve.
7. Shows inner cam shaft.
8. Shows bore of hydraulic drill collar.
9. Shows hydraulic drill collar.

Figure 24 is a radial cross-section of a caliper thrust unit piston showing:-

18. Shows caliper thrust piston and seals.
19. Shows caliper piston return spring.
22. Shows end plug and piston stop.
43. Shows valve cylinder body.
53. Shows retaining thread to angle thrust block.
54. Shows fluid chamber.
56. Shows piston seals.

Figure 25 is a radial cross-section of the hydraulic drill collar piston valve assembly and cylinder body with telemetry unit controllers and valve control spool, telemetry unit controllers for dump valves showing:-

1. Shows thrust telemetry unit controller.
2. Shows return telemetry unit controller.
3. Shows valve control spool thrust side.
4. Shows valve control spool return side.
9. Shows flow port into item: 1 telemetry unit controller.
10. Shows flow port into item: 2 telemetry unit controller.
11. Shows exhaust out port return side.
12. Shows exhaust out port thrust side cylinder.
143. Shows flow control port to piston dump valve.
145. Shows flow control port to cylinder dump valve.
15. Shows flow port in piston dump valve.
16. Shows flow port out cylinder dump valve.
17. Shows inlet feed to thrust caliper pistons.
21. Shows seal hydraulic drill collar to caliper cylinder body.
30. Shows hydraulic drill collar (piston).
33. Shows cylinder chamber return side.
36. Shows caliper body control sub cylinder rear.
37. Shows hydraulic drill collar piston valve assembly.
38. Shows back cylinder body valve sub.
40. Shows cylinder chamber thrust side.
42. Shows seals for cylinder spool.

46. Shows seals striker piston cylinder.
47. Shows seals in cylinder body.
48. Shows seals in hydraulic drill collar piston assembly.
49. Shows seals spool valve piston.
50. Shows cylinder body TUC dump valve.
51. Shows thread on valve control sub hydraulic drill collar.
53. Shows hydraulic drill collar piston valve assembly TUC dump valve.
54. Shows flow port to caliper pistons.
55. Shows control piston to no. 1 TUC.
56. Shows control piston to no. 2 TUC.
61. Shows camshaft and striker piston.
64. Shows control cam.
65. Shows camshaft/striker piston cylinder.
66. Shows connection control spool.
67. Shows spring locator (spool valve).
68. Shows striker plates valve control spool.
69. Shows spool valve piston and torque rod.
70. Shows bore for cam.

Figure 26 is a radial cross-section of a TUC with fluid valve spool type showing:-

1. Shows control unit body (front and rear).
2. Shows pressure control piston (actuator).
3. Shows fluid valve spool.
4. Shows inlet port.
5. Shows outlet port.
6. Shows spring adjuster.
7. Shows male and female threads.
8. Shows actuator housing.
9. Shows toggle bar.
10. Shows latch plate open.
11. Shows pressure inlet port.
12. Shows latch plate closed.
13. Shows toggle latch.
14. Shows toggle housing.
15. Shows spring.

Figure 27 shows a radial cross-section of a dual acting telemetry unit controller showing:-

1. Shows telemetry unit controller body.

2. Shows outlet from pump (off) chamber.
3. Shows inlet from pump (on) chamber.
4. Shows outlet from pump (on) chamber.
5. Shows inlet from pump (off) chamber.
6. Shows inlet pilot pressure drilling fluid in.
7. Shows dual piston spool.
8. Shows piston spool return spring.
9. Shows metering piston (angle).
10. Shows metering piston (straight).
11. Shows return springs.
12. Shows metering ports.
13. Shows seals.
14. Shows metering chamber (angle).
15. Shows metering chamber (straight).

ADVANTAGE OF THE CALIPER THRUST UNIT (CTU)

1. Allows the use of angle blocks to thrust out and retract caliper blades in any down-hole drilling equipment.
2. Allows the use of centre side ports and valve assemblies, used inside thrust caliper units to control the hydraulic drill collar for adding weight to the drill bit in any form of caliper assembly or any down-hole drilling equipment.
3. Allows the use of a toggle/latch pressure pulse valve assembly.
4. Allows the umbilical thrust calipers to stop back wrapping of the tubing (tube torquing) with coiled tubing drilling unit.
5. Allows the use of a toggle/latch pressure pulse valve assembly with a shear gate assembly or thrust piston.
6. Allows the use of telemetry unit controllers in hydraulic drilling thrust caliper units.
7. Allows for continual automatic drilling operation of forward thrust and reverse with the use of telemetry unit controller (TUC) valves actuated by hydro mechanical means within a hydraulic drill collar caliper system with down-hole drilling fluid pressure.
8. Allows for a drilling fluid dump valve system either single use or in pairs with the telemetry unit controller (TUC) valves.
9. Allows the use of hydraulic and hydro mechanical adjustable down-hole tools to be used with the telemetry unit controller valve.
10. Allows multiple hydraulic and hydro mechanical adjustable tools to be used and controlled individually down-hole with the use of telemetry unit controller valves.
11. Allows the use of adjustable down-hole tools to be in coiled tubing operation without the use of multi-conduit lines for full down-hole tool control.
12. Allows drill pipe to be used with coiled tubing between a pair of thrust caliper units (TUC's) and the drilling motor with trajectory control unit.

Positive displacement drilling motors

Another aspect of the present invention provides a trajectory control unit and, preferably, a positive displacement drilling motor with at least one motor housing trajectory control unit. Such tools are a valuable aid in the drilling of multidirectional wells, such as those required to implement the first part of the invention.

Embodiments of this part of the invention are shown in figures 227 to 43 of the accompanying drawings.

To drill horizontal wells total control of the down-hole assembly is imperative, to drill long reach wells with conventional drill pipe or coiled tubing. This invention employs a double motor housing bend sub (telemetry unit controller) fitted to the bottom of the rotor stator motor housing, with the sealed bearing and output shaft incorporated in the near bit stabiliser housing and bottom pivot body sub. This innovation opens up a complete new field for drilling practices, and will realise significant cost savings over present methods now in use.

The first string stabiliser is adjustable between full gauge and under gauge that can be used for holding or dropping angle on bottom hole assembly in conjunction with the double bend (TCU) for kicking off the well or building angle, allowing a fully steerable motor system.

Configurations of bottom hole assembly designs can vary, each configuration is designed to perform total directional control with the down-hole motor orientated in a particular direction by drill string rotation or by the orientation unit when used with coiled tubing, and to drill straight ahead by re-setting the double bend unit. The straight position by the pre-determined pressure increase to the telemetry unit controllers (TUC's). This avoids totally dog legs within the well bore which can be used to plan and select a fully automated down-hole steerable assembly, which will drill a pre-determined well path.

The trajectory control units, telemetry unit controllers calibrated fluid chamber allows for 0.25 degree permitted build rate increments put to 3 degrees, the two bends are featured in opposite directions which tilts the bits axis from the hole axis to enable a down-hole system to drill a curve when orientated in the right position. Drilling straight ahead requires a pressure change or pump on/off to go back to zero, this allows minimum bit offset reducing bit side loading. A single bend motor housing can also be used to achieve a variety of build rates, this is ideal for re-entry work, two single trajectory control units, giving the drilling motor adjustment below and above the motor. The reamer action on the first string stabiliser is employed to smooth the

well bore, stabilise the assembly and straighten the well bore where kinks and dog legs are encountered. These unique features allow directional adjustments to be made from the rig floor while the drilling assembly is down-hole.

Extended bearing life is obtained by the sealed bearing assembly housed within the near bit stabiliser body and pivot sub, this allows all of the drilling fluid to be circulated through the bit for the maximum bit hydraulics and cleaning. Sealed bearing assemblies are lubricated by high temperature oil and fitted with high temperature seals. A dump sub valve is located at the top of the drilling motor to allow drilling fluid to by-pass the motor and fill the drill pipe while tripping into the hole, it also permits draining of the drill pipe when tripping out of the well or making a connection, closure occurs automatically with pump activation.

The universal joint assembly (flex joint) converts offset motion to the rotary drive shaft, effectively transferring power from the motor assembly. It is designed with a 1 to 2 or multi-helix configuration for high torque low speed output or low torque high speed output.

The trajectory control unit is controlled by a power section that employs a helical type screw sleeve and piston, round or square section with seals on the top and bottom of the piston fitted inside the main cylinder body with top and bottom housing subs, rotation of the piston is prevented by a guide rod and guide tube running through the piston and held in place by the top and bottom housing subs, the helical screw sleeve is fitted with eccentric cams, one facing in the opposite direction. The telemetry unit controller is fitted into the bottom housing sub and is controlled by the guide tube running through the piston. The unit is charged by means of a refill valve fitted in the side of the bottom housing sub allowing the bottom fluid outlet chamber to be pressurised and pushing the piston to the top start position. The length of the helical screw and depth together with the fluid outlet chamber will determine the amount of rotations of the helical screw sleeve before the outlet fluid chamber requires recharging, rotation of the helical screw sleeve is allowed when fluid from the outlet fluid chamber is bled out of the telemetry control unit allowing the piston to travel downwards by drilling fluid entering into the top fluid inlet chamber via the non-return inlet valve, this in turn allows the rotation of the eccentric (bottom and top) trajectory crank cams to allow 0.25 degree angle change each time the telemetry control valve is operated by a pre-determined pressure increase from the rig floor. This same system of piston drive power section is also used in the orientation unit, but with a bottom sealed bearing thrust sub and larger fluid chamber in the telemetry control valve allowing one (1) degree upwards directional orientation control.

The purpose of the trajectory control unit is to control the direction of drilling down-hole from the surface. The main elements of the device are; (1) a pivot sub in

the trajectory unit and a swivel thrust sub in the orientation unit with zero to three degrees trajectory control and 360 degree directional orientation with one degree or more increments, (2) the piston drive shaft pressure assembly to produce the movement and (3) a telemetry unit controller to control the piston and rotary shaft movement by pressure impulses injected into the drilling fluid at the surface (pre-determined momentarily increase in drilling fluid pressure) by means of applying pressure to force the piston down, powering the drive sleeve is by direct drilling fluid pressure, the piston pressure is a constant proportion of the drilling fluid pressure.

The number of actuations possible before tripping to recharge the power section is determined by piston stroke and helical screw sleeve. The telemetry unit controller is activated by a pressure pulse in the drilling fluid line and on actuation metres a defined volume from the power section, the required surface control feature thus results, correct sizing of the various elements, to achieve for example, one pulse equals 0.25 of trajectory change, it is designed to actuate within a window of drilling fluid pressure, for instance if drilling pressure was normally 1,600 psi the valve could be arranged to actuate in the trajectory control unit at 2,200 psi for trajectory change, after actuation the pressure would have to fall back to below say 1,900 psi before another actuation was possible, this would also activate the orientation unit, but this would not be significant, as to set directional orientation would be performed last at a pressure below trajectory change, say 2,000 psi, after actuation the pressure would have to fall back to 1,700 psi before another actuation was possible.

The reamer/stabiliser fitted with a telemetry unit controller with thrust piston and rod, this unit consists of a valve housing body and actuator body, the valve housing body incorporates a thrust piston and rod held in place by a piston return spring, tension on the spring is adjustable by means of a spring adjuster, the piston and rod is activated by a toggle and latch fitted inside a toggle and latch housing that houses a toggle open latch plate, and a toggle close latch plate that is operated by an actuator piston fitted in the actuator body, when the toggle is on the toggle open latch the reamer/stabiliser is in full gauge position, when the toggle is in the close latch position the reamer/stabiliser is in the under gauge position, as shown in the toggle actuation diagram.

A pressure spring may also be fitted above the helical thrust piston inside the top fluid inlet chamber for continual pressure on the piston, and without the use of a non-return valve for drilling with two (2) phase fluids. A single or multi helical screw or lobe type can be used in the piston and rotary sleeve.

The dual action telemetry unit controller (TUC) allows tripping in and out of the well in the straight ahead mode. The (TUC) is activated by pump pressure when the pumps are on. The metering piston in the (TUC) travels forward and allows

rotation of the rotor sleeve allowing trajectory control bit angle face as the piston displaces fluid from the bottom chamber through the (TUC), when the pumps are shut off the metering piston returns and displaces fluid from the bottom chamber allowing the piston to travel downwards rotating the rotor sleeve allowing the bit angle face to return to the straight ahead position for tripping out of the well. The trajectory control unit and orientation control unit can also be controlled by pulses within the drilling fluid to activate the telemetry unit controller (TUC) with pulse control unit fitted.

The cam action in the fork can be set for the dual action telemetry valve to be used to change angle with pump on and pump off positions, ie. pump off straight ahead 0 degree, pump on 1 degree angle (drill), pump off 1.5 degree angle, pump on 2 degree angle (drill), pump off 2.5 degree angle, pump on 3 degree angle (drill), pump off 0 degree angle well bore to drill straight ahead when down-hole, the first position would be changed by the setting of the can face design, this will allow angle face changes by pump on and off without any hydraulic pressure increase or pulse changes down-hole, a drilling record will need to be recorded on the amount of pump stopping and starting to determine bit angle face.

The size of the metering chamber determines the amount of piston travel and rotation of the drive sleeve and degree angle of bend.

Figure 27 shows a radial cross-section of a trajectory control unit (TCU), and down-hole motor sealed bearing assembly (double bend sub or single).

1. Shows piston helical rotary sleeve.
2. Shows eccentric trajectory crank (cam).
3. Shows anti-rotational cross bar, radial bearings with top and bottom radial seals.
4. Shows pivot body sub.
5. Shows output thrust shaft.
6. Shows universal joint assembly.
7. Shows radial bearings output shaft to pivot sub.
8. Shows pivot ball joint with bore and top fork.
9. Shows male (pin) thread pivot sub to body.
10. Shows bottom male (pin) thread pivot ball joint to stabiliser body.
11. Shows pivot ring seat retainer.
12. Shows top stabiliser/output shaft retaining housing.
13. Shows top radial seal.
14. Shows thrust (lock ring) bearing.
15. Shows thrust bearings.
16. Shows lower output thrust shaft and bit box connection.
17. Shows stabiliser sleeve.

18. Shows bottom stabiliser sleeve and bearing housing retaining sub.
19. Shows bottom radial seal.
20. Shows seal retaining clip.
21. Shows cylinder body.
22. Shows thrust piston helical.
23. Shows piston guide control tube and seals.
24. Shows piston guide rod and seals.
25. Shows piston seal.
26. Shows piston helical rotary sleeve.
27. Shows output thrust shaft.
28. Shows bottom bearing and TCU control sub.
29. Shows top bearing and tube control sub.
30. Shows lock nut and seal control tube.
31. Shows lock nut and seal guide rod.
32. Shows helical screw male (sleeve).
33. Shows helical screw female (piston).
34. Shows bearing radial bottom on helical rotary sleeve.
35. Shows bearing radial top on helical rotary sleeve.
36. Shows refill valve port.
37. Shows radial seals for rotary sleeve bottom.
38. Shows radial seals for rotary sleeve top.
39. Shows bore of output thrust shaft.
40. Shows top double (or single) trajectory control unit/sealed bearing assembly connection to down-hole drilling motor.
41. Shows top fluid inlet chamber.
42. Shows inlet port and non-return valve.
43. Shows inlet port telemetry unit controller (TUC).
44. Shows outlet fluid chamber.
45. Shows outlet fluid port from telemetry unit controller (TUC).
46. Shows flexible connection between swivel sub fork item 8 and item 29 top bearing and tube control sub to item 42 inlet port and item 43 control (TCU) port.

Figure 27a shows a sub-assembly, the detail of which is essentially shown in figure 34.

Figure 28 shows an axial top section of item 8 pivot ball joint with bore and top fork.

1. Shows piston helical rotary sleeve.
2. Shows eccentric trajectory crank (CAM).

3. Shows anti-rotational cross bar, radial bearings and with top and bottom radial seals.

4. Shows pivot body sub.

5. Shows output thrust shaft.

7. Shows radial bearings output shaft to pivot sub.

8. Shows top fork on item 8 pivot ball joint.

Figure 29 shows an axial cross-section of the trajectory control unit, cylinder body and piston with piston guide control tube and rod.

21. Shows cylinder body.

22. Shows thrust piston.

23. Shows piston guide control tube.

24. Shows piston guide rod.

25. Shows piston seal.

26. Shows piston helical rotary sleeve.

27. Shows output thrust shaft.

Figure 30 shows a radial cross-section of item 46 flexible connection.

47. Shows seal cup with flexible ball joint.

48. Shows seals cup ball.

49. Shows seal cup.

50. Shows seal spring.

51. Shows item 8.

52. Shows item 29.

Figure 31 shows a radial cross-section of a fluid dump valve.

1. Shows box connection.

2. Shows valve body.

3. Shows piston.

4. Shows spring.

5. Shows piston bore.

6. Shows dump port piston.

7. Shows pin connection.

8. Shows dump port body.

Figure 32 shows a radial cross-section of a down-hole drilling motor.

53. Shows motor body.

54. Shows stator (rubber type compound) 1 - 2 or multi-helix.

55. Shows rotor with or without through bore 1 - 2 or multi-helix.

56. Shows top connection female box.

57. Shows bottom connection female box to female box.

58. Shows connection for universal joint to output thrust shaft.

59. Shows axial cross-section of rotor/stator.
60. Shows axial cross-section of rotor/stator.

Figure 33 shows a diagrammatic drawing of a drilling assembly for directional/horizontal drilling.

1. Shows drill string or coiled tubing.
2. Shows orientation unit if used with coiled tubing.
3. Shows adjustable first string reamer/stabiliser.
4. Shows dump valve.
5. Shows down-hole drilling motor.
6. Shows (single bend) trajectory control unit (TCU).
7. Shows reamer body sealed bearing thrust assembly.
8. Shows drill bit.

Figure 34 shows radial cross-sections of a telemetry unit controller (TUC) (fluid metering type).

- A. Shows initial condition.
- B. Shows pressure pulse received.
- C. Shows metered volume fills.
- D. Shows pulse decays and metered volume empties.
5. Shows control unit body.
6. Shows metering piston.
7. Shows pressure control piston.
8. Shows metering spring.
9. Shows pressure spring.
10. Shows inlet port.
11. Shows outlet port.
12. Shows pressure port.
13. Shows metered volume.

Figure 35 shows radial cross-sections of a telemetry unit controller (TUC) (hydraulic thrust type).

1. Shows control unit body (front and rear).
2. Shows pressure control piston (actuator).
3. Shows thrust piston and rod.
4. Shows spring adjuster.
5. Shows male and female threads.
6. Shows actuator housing.
7. Shows toggle bar.
8. Shows latch plate open.
9. Shows pressure inlet port.

10. Shows latch plate closed.
11. Shows toggle latch.
12. Shows toggle housing.

Figure 36 shows a radial cross-section of the toggle bar and toggle latch with latch plates, showing the seven (7) positions.

Figure 37 shows a diagrammatic drawing of two (2) single trajectory control units in a drilling assembly.

1. Shows adjustable reamer stabiliser.
2. Shows dump valve.
3. Shows trajectory control unit (TCU) top.
4. Shows down-hole drilling motor.
5. Shows trajectory control unit (TCU) bottom.
6. Shows stabiliser and sealed bearing assembly.
7. Shows drill bit.

Figure 38 shows a diagrammatic drawing of a single trajectory control unit in a drilling system.

1. Shows adjustable reamer stabiliser.
2. Shows dump valve.
3. Shows trajectory control unit (TCU).
4. Shows down-hole drilling motor.
5. Shows stabiliser and sealed bearing assembly.
6. Shows drill bit.

Figure 39 shows radial cross-section of an orientation unit.

1. Shows orientation tool body.
2. Shows piston helical rotary orientation shaft.
3. Shows thrust sub rotary ball assembly body.
4. Shows radial top bearing cup assembly.
5. Shows thrust bearings bottom cup.
6. Shows seals (rotary).
7. Shows top control inlet sub.
8. Shows bottom outlet control sub.
9. Shows control torque tube.
10. Shows control torque rod.
11. Shows torque nut and seal for tube.
12. Shows torque nut and seal for rod.
13. Shows helical piston thrust control.
14. Shows charging valve port.
15. Shows telemetry unit controller (TUC).

16. Shows outlet port.
17. Shows rotary ball shaft output sub.
18. Shows pin thread connection.
19. Shows orientation ball top bearing assembly.
20. Shows box connection.
21. Shows inlet port to TUC tube.
22. Shows top chamber.
23. Shows female helical thread piston.
24. Shows male helical thread drive shaft.
25. Shows pin thread from ball to shaft.
26. Shows inlet port to piston.
27. Shows top sub.
28. Shows seals for TUC tube.
29. Shows drive keys.
30. Shows bottom chamber.

Figure 39a shows a sub-assembly which is essentially the same as that shown in figure 34.

Figure 40 shows a diagrammatic view of a twin bend housing assembly trajectory control unit (TCU) as per figure 27.

1. Shows adjustable reamer/stabiliser.
2. Shows dump valve.
3. Shows down-hole drilling motor.
4. Shows twin bend trajectory control unit (TCU).
5. Shows stabiliser and sealed bearing assembly.
6. Shows drill bit.

Figure 41 shows a radial cross-section of a universal joint and output thrust shaft.

9. Shows pin connection.
10. Shows constant velocity universal joint.
11. Shows flow port.
12. Shows bore.
13. Shows output shaft.

Figure 42 shows a radial cross-section of a trajectory control unit (TCU) and down-hole motor sealed bearing assembly (single bend sub).

1. Shows piston helical rotary sleeve.
2. Shows eccentric trajectory crank (CAM).

Shows anti-rotational cross bar, radial bearings with top and bottom radial seals.

4. Shows pivot body sub.
5. Shows output thrust shaft.
6. Shows universal joint assembly.
7. Shows radial bearings output shaft to pivot sub.
8. Shows pivot ball joint with bore and top fork.
9. Shows male (pin) thread pivot sub to body.
10. Shows bottom male (pin) thread pivot ball joint to stabiliser body.
11. Shows pivot ring seat retainer.
12. Shows top stabiliser/output shaft retaining housing.
13. Shows top radial seal.
14. Shows thrust (lock ring) bearing.
15. Shows thrust bearings.
16. Shows lower output thrust shaft and bit box connection.
17. Shows stabiliser sleeve.
18. Shows bottom stabiliser sleeve and bearing housing retaining sub.
19. Shows bottom radial seal.
20. Shows seal retaining clip.
21. Shows cylinder body.
22. Shows thrust piston helical.
23. Shows piston guide control tube and seals.
24. Shows piston guide road and seals.
25. Shows piston seal.
26. Shows piston helical rotary sleeve with bearing journals.
27. Shows output thrust shaft.
28. Shows bottom bearing and TCU control sub.
29. Shows top bearing and tube control sub.
30. Shows lock nut and seal control tube.
31. Shows lock nut and seal guide rod.
32. Shows helical journals male (sleeve).
33. Shows helical journals female (piston).
34. Shows bearing radial bottom on helical rotary sleeve.
35. Shows bearing radial top on helical rotary sleeve.
36. Shows refill valve port.
37. Shows radial seals for rotary sleeve bottom.
38. Shows radial seals for rotary sleeve top.
39. Shows bore of output thrust shaft.
40. Shows top double (or single) trajectory control unit/sealed bearing assembly connection to down-hole drilling motor.

41. Shows top fluid inlet chamber.
42. Shows inlet port and non-return valve.
43. Shows inlet port telemetry unit controller (TUC).
44. Shows outlet fluid chamber.
45. Shows outlet fluid port from telemetry unit controller (TUC).
46. Shows flexible connection between swivel sub fork item 8 and item 29 top bearing and tube control sub to item 42 inlet port and item 43 control (TCU) port.
47. Shows micro-logic control valve.
48. Shows battery pack (activator unit/receiver unit).
49. Shows ball bearings.

Figure 42a is basically the same as figure 34.

Figure 42b shows an alternative arrangement to figure 42a.

Figure 43 shows the main mechanism of the figure 42b arrangement to a larger scale.

TRAJECTORY CONTROL POSITIVE DISPLACEMENT DRILLING
MOTORS TRAJECTORY CONTROL UNIT (TCU)
ADVANTAGES

1. Allows trajectory control down-hole from the surface with a double bend motor body with a helical screw piston and helical screw sleeve controlling eccentric crank (CAM) via a pivot sub and telemetry unit controller valve to meter a defined volume of fluid to control piston travel and rotary movement.
2. Allows orientation control down-hole from the surface with a helical screw piston and helical screw sleeve connected to a rotary thrust bearing sub and telemetry control valve to meter a defined volume of fluid to control piston travel and rotary movement.
3. Allows the use of an accumulator (weight set) to control the telemetry unit controllers thrust piston, to control the movement of the reamer/stabiliser blades within the reamer/stabiliser body.
4. Allows for a down-hole drilling motor to house the double motor body bends, and for the bottom section to retain a stabiliser sleeve, held in place on the bottom bend section stabiliser sleeve body that houses the thrust bearing and radial bearings, also radial seals in the bottom pivot sub, allowing full thrust loads to be directly applied to the bottom part of the assembly before the first bend, and radial bearings in the second bend allowing for shorter bend sub units.
5. To allow total steerability this system employs a positive displacement motor with a double motor housing bend (trajectory control unit), telemetry control allows the motor to drill a curve and remain down-hole to drill a tangent section so that the double bend can be set in the straight ahead position by telemetry control. To remain concentric with the bit to the hole at all times allowing maximum cutting efficiency. Two stabilisers, the upper one adjustable determines the directional performance of the bottom hole assembly.

The two stabilisers and the bit serve as tangency points, the top stabiliser being adjustable has fine control that defines a constant radius arc oriented hole curvature, build rate can be adjusted down-hole by telemetry control varying the trajectory control units (double bend motor body) angle setting, allowing total trajectory and orientation control down-hole from the rig floor by telemetry control.

6. Allows total down-hole control with this system by the use of adjustable first string reamer/stabiliser and fixed near bit stabiliser with trajectory control units (TCU's) fitted between the two stabilisers, either one or more trajectory control units can be used predicting how a given bottom hole assembly (BHA) will perform by contact points with the bore hole wall, the two stabilisers and the bit serve as tangency

points that define a constant radius arc along which the assembly will drill when orientated. Hole curvature, or design build rate, can be adjusted by varying the trajectory control unit angle, the variable diameter and the placement of the first string reamer/stabiliser. During drilling, build rates can be fine tuned by telemetry control down-hole to the trajectory control unit for precise directional control.

7. Allows the use for short radius drilling with multiple trajectory control units fitted with telemetry unit controllers to the drill string or coiled tubing, to build wellbore inclination to horizontal 90 degree on a radius of only 40 feet with short motor section with precise directional control over inclination and hole azimuth and will drill horizontal extended reach of over 2,000 feet. This system does not require string rotation which is the cause of critical hole damage, allows fewer trips for BHA changes.
8. Allows the use for medium radius steerable angle build with build rates of up to 20 degrees per 100 feet with two trajectory control units for horizontal and "J" type wellbores and caliper thrust units.
9. Allows the use for long radius steerable angle build with one or two trajectory control units for build rates of up to 5 degrees per 100 feet for horizontal and "J" type "U" type wellbores with caliper thrust units.
10. Allows total down-hole directional control without the use of umbilical lines from the drill floor in single and two phase drilling fluids with coiled tubing or drillpipe.
11. Allows down-hole control of the trajectory control unit and orientation unit by the length of the piston helical threads or lobes and drive sleeve helical threads and lobes, that will determine the amount of rotation of the drive sleeve, the boom chamber returns the piston back when recharging in the accumulator type unit, the telemetry unit controller meters a pre-determined amount of fluid from the chamber allowing rotation of the drive sleeve for trajectory or orientation control by pre-determined pressure increases.
12. Allows the use of composite flexible joints in trajectory control unit tools.
13. Allows the use of any design of the standard or umbilical orientation or trajectory control stabiliser tool, also covers any type of eccentric/concentric type pump/motor design that can be used in this type of tool to enable its use to give single control of the drilling unit for directional drilling control, it is intended that any type of rotor stator piston sleeve system or epitrochoid chamber trirotor (equilateral triangle) rotor is included.
14. Allows total orientation control down-hole with the use of telemetry unit controller (TUC) and helical screw piston/helical screw sleeve or helical lobes.

15. Allows the use of an accumulator type hydraulic power section to control down-hole drilling tools.
16. Allows the use of a fork type lever with a pivot to swivel (knuckle joint) on a top and bottom bearing plate housings by the use of eccentric or concentric CAMs that prevents rotation by the use of cross tie bar through the fork to the sides of the body.
17. Allows the use of an adjustable blade type reamer/stabiliser fitted within the drill string in conjunction with trajectory control, orientation control by hydraulic pressure increased in the telemetry unit controller, or micro-logic unit by control from the rig floor down-hole in controlling the tangent control points.
18. Allows the use of a replaceable sleeve or fixed type stabiliser on a down-hole bearing assembly used in the telemetry unit controlled, trajectory control unit or orientation unit for directional drilling control.
19. Allows the use of adjustable bend or bends in the drill string to be controlled down-hole when drilling by telemetry hydraulic unit control by micro-logic unit or the increase in drilling pressure for directional drilling and being able to return back to the straight mode of drilling without pulling the drill string or coiled tubing from the well.
20. Allows the trajectory control unit to be used with or without near bit stabiliser and or sealed bearing housing.
21. A deflection side pad can also be fitted to the bottom sub figure 18 items 17 and 18 to allow directional drilling control.
22. Allows the use of special high pressure and high temperature elastomers and rubber type compounds over 350°C. Working temperature, with high durometer (shore-hardness) to stop leakage past the rotor/stator in drilling motors, for use in high pressure and high temperature wells, allowing high flow rates for hydraulic and well cleaning returns.
23. Allows high pressure and high temperature seals to be used above 350°C in all down-hole tools.
24. Allows an adjustable hydraulic deflection pad controlled by angle blocks to be used within the motor body housing trajectory control unit behind the adjustable bent housing.
25. Allows trajectory control, orientation control and side thrust pad control, for maximum drilling control by micro-logic mud pulse signals, negative type by a transmitter surface unit to a down-hole receiver/activator unit in tool bodies, to control the telemetry unit controllers.

Compensating underreamer

Another aspect of the present invention provides a compensating underreamer. This tool is a valuable aid in the drilling of multidirectional wells, such as those required to implement the first part of the invention. An embodiment of the tool is shown in figure 44 of the accompanying drawings.

This tool uses side ported pistons and cylinders fitted around the outside of the tool body, around the bore, two three or four to operate the corresponding cutter arms, this system allows single action to each cutter arm by the hydraulic piston action onto the thrust piston road, when the pumps are on, delivering down-hole pressure by drilling fluid onto the pistons, pushing forward the thrust pistons onto the thrust blocks, that in turn drive the cutter arms forward and outwards by the use of cam guide slots in the body of the underreamer housing for the cutter arm assembly, by milling in curved slots, with corresponding guide pin roller, in the side of the tool body, like a dowel type pin through the cutter arm, allowing the outward movement of the cutter arms, and retraction in the reverse operation when the micro-logic activator/receiver unit, pulse signal in the drilling fluid pressure is received, allowing the cutter arms to retract into the closed position, by the return springs fitted to the hydraulic pistons, allowing complete simultaneous closing and opening, each time the micro-logic valves are operated.

The underreamer is a tool designed to pass through a restriction, opening up below the restriction to clean out the hole to full gauge and then close up again to be retrieved from the well-bore, normally the restriction is the production tubing and other production accessories in the string.

The underreamer should open out to a diameter of about 0.5 inches less than the diameter of the liner, the tool is again actuated by a mid-pulse in the drilling fluid to activate the control thrust pistons by pressure on the hydraulic pistons, which move to activate the thrust pistons to force the blades open, by differential pressure across the piston faces, when the pressure is released to close the tool, the sequence is reversed and does not require hydraulic pressure to keep the tool closed, as is the case with other types of underreamer.

The blades cannot close up when drilling and will always disengage when activated in the closed position. With cutter lubrication and jetting, within the blade area for any solid particles in the return flow, to be jetted away by the hole opener/milling tool pressure to stop any solids locking up the tool whilst in use. When

used as an underreamer the bottom of the tool is fitted with a cutting type face to form a flat pilot hole for the underreaming tool.

The hole opener/milling tool works on the same principle and is ideal for opening up the well-bore below the casing point or for cutting the section of casing away to expose the well-bore formation for opening up the hole, ie. side tracing for lateral and horizontal drilling.

The electro-hydraulic hardware consists of a signal transmitter unit located at the surface, and a pulse signal receiver unit located in the activator unit, in either the trajectory control unit, orientation control unit, reamer stabiliser unit, thrust pad unit, underreamer unit and the dump valves on the caliper thrust units, to control the telemetry unit controllers.

The transmitter unit consists of a single chip microcomputer unit and a power amplifier, two switches, on/off, activate the microcomputer and solenoid valves, operate the pressure pulse valve.

The receiver unit consists of a pressure transducer and amplifier, analog to digital converter, single chip microcomputer watch dog power amplifier battery power supply, with oil/nitrogen accumulator, solenoid valve and mud valve, the solenoid valve is used to activate the mud valve, which controls the telemetry unit controller. The watch dog is a circuit which is used to reset the microcomputer unit, in case of failure due to electromagnetic noise, etc. The circuit is also used to avoid uncontrolled activation of the solenoid valve.

Figure 44 shows a radial cross-section of a compensating underreamer, hole opener/milling tool (cut) showing:-

1. Shows box thread connection.
2. Shows pin and box connection top sub.
3. Shows feed port to pistons.
4. Shows fluid chambers and micro-logic control valve.
5. Shows piston seals.
6. Shows hydraulic thrust piston assembly and thrust rod (open).
7. Shows thrust head return spring (open).
8. Shows connection pin thread to thrust head guide block.
9. Shows thrust head guide block (open).
10. Shows cutter arm swivel pin.
11. Shows cutter arm assembly (2, 3 or 4 arms (open) 3).
12. Shows locking guide slot pins in cutter arms.
13. Shows locking guide slots (closed) in tool body.
14. Shows milled tooth cutters on bearings (2, 3 or 4 cutters) or other

types.

15. Shows housing for cutter arm assembly.
16. Shows body of underreamer.
17. Shows box thread connection.
18. Shows thrust head guide block assembly.
19. Shows top sub seal.
20. Shows top sub.
21. Shows bore of underreamer.
22. Shows battery pack activator/receiver unit.

ADVANTAGES OF THE COMPENSATING UNDERREAMER

1. Allows the use of two (2), three (3) or four (4) side ported pistons and cylinders to control cutting arms in underreamers, hole openers and milling tools.
2. Allows full through bore in the underreamers, hole openers and milling tools with side pistons and cylinders for improved down-hole hydraulics and cleaning.
3. Allows the use of thrust blocks controlled by thrust pistons, to thrust forward and out the cutter arms in underreamers, hole openers and milling tools.
4. Allows the use of milled curve guide slots in the underreamer body, and dowel type bearing pins in the cutter arms to control the outward and inward movement of the cutter arm assembly in underreamer, hole opener and milling tools.
5. Allows the use of side hydraulic pistons, cylinders and return springs, to compensate for the outward and inward action of the cutter arms within underreamers, hole openers and milling tools.

6. Allows the use of a micro-logic activator/receiver unit by rig floor transmitter controlled drilling mud pulse, for control of the cutter arms in underreamers.

Trirotor Positive Displacement Mud Drilling Motor

Another aspect of the present invention provides a Trirotor Positive Displacement Mud Drilling Motor. This tool is a valuable aid in the drilling of multidirectional wells, such as those required to implement the first part of the invention. An embodiment of the tool is shown in figures 45 and 46 of the accompanying drawings.

The epitrochoidal rotary cylinder and trirotor is an ideal method when used as a drilling mud motor which has advantages over the normal rotor/stator type motor due to the absence of the rubber compound type stator/rotor which will not perform in temperatures in excess of 350 degrees F. As the epitrochoidal rotor chamber/trirotor stator has no rubber compound sealing arrangement.

The epitrochoidal rotor cylinder is rotated round the fixed thrust bearing sub by the fixed drive pinion gear shaft connected to the fixed thrust bearing sub by a non rotating constant velocity flexible joint to allow orbital movement of the outer epitrochoidal casing rotor by the force of drilling fluid pumped under pressure through the peripheral two inlet ports machined into the sides of the epitrochoidal rotor cylinder, rotating the trirotor and discharging the drilling fluid through the peripheral two outlet ports.

The long inlet and outlet peripheral ports never close. This leads to volumetric efficiency in excess of 100%. The fixed drive pinion is held in place at the bottom of the epitrochoidal rotor cylinder in a central position and secured in the trirotor at the top end by an eccentric crank, and the trirotor is connected to the epitrochoidal rotor cylinder by a further eccentric crank allowing a fixed orbital motion of the trirotor within the epitrochoidal rotary cylinder by the fixed inside gear fitted central to the trirotor faces rotates the epitrochoidal rotary cylinder in a concentric outer rotation around the thrust bearing sub while the trirotor stator moves in a stationary orbital movement as fluid is pumped through to both peripheral outlet ports.

The position of the trirotor in the epitrochoidal rotary chamber is shown in figure 46. The peripheral inlet and outlet ports as shown in figure 46 - 6 outlet port and - 7 inlet port.

Figure 45 shows epitrochoidal rotor/trirotor stator positive displacement mud drilling motor with fixed orbital trirotor stator and rotary epitrochoidal outer rotor with rotary stabiliser showing:-

1. Thrust collar.
2. Shows female box connection.
3. Shows inlet chamber.

4. Shows fluid ports in fixed orbital flexible joints.
5. Shows top eccentric guide thread.
6. Shows peripheral inlet port.
7. Shows bearing for eccentric crank (internal gear and pinion).
8. Shows eccentric crank inside internal gear and splined pinion guide.
9. Shows epitrochoidal bore.
10. Shows trirotor stator.
11. Shows splines on internal gear.
12. Shows splines on pinion.
13. Shows pinion.
14. Shows retaining key for pinion.
15. Shows fixing recess for pinion in bottom sub.
16. Shows outlet flow port.
17. Shows female box connection for drill bit.
18. Shows bottom sub.
19. Shows splines on pinion.
20. Shows splines on internal gear.
21. Shows peripheral outlet port.
22. Shows pinion bearings in eccentric gear crank.
23. Shows drive head from trirotor stator to fixed flexible joint.
24. Shows main rotor body.
25. Shows bearings for top eccentric trirotor crank.
26. Shows fixed flexible joint.
27. Shows thrust bearing sub.
28. Shows top fluid port.
29. Shows thrust bearings.
30. Shows rotary bearings.
31. Shows top sub.
32. Shows stabiliser straight blade or spiral type.

Ulatalobe Cavity Trirotor Displacement Pump/Motor

Another aspect of the present invention provides a Ulatalobe Cavity Trirotor Displacement Pump/Motor. This tool is a valuable aid in the drilling of multidirectional wells, such as those required to implement the first part of the invention. An embodiment of the tool is shown in figure 47 of the accompanying drawings.

This part of the invention provides an alternative outer pump casing, with internal helix, a fixed female external helix outer stator with internal helix and a fixed male inner external helix fitted to the pump end casing at one end and the central male external helix/female internal helix rotor drive head fitted within the two stators by a constant velocity flexible connecting joint. The use of one male/female cylindrical rotor, spinning inside the outer female stator and inside the central male stator ensures that cavities are formed and progress in an upward or downward direction, depending upon the rotation of the pump or motor. Fluid enters the cavities and is driven through the rotors, stators/stator.

The lobes on the rotors/stators form cavities between the cylindrical multi-helix male/female rotor and the male/female stators as the cylindrical male/female rotor turns about its eccentric rotation around the outer male stator and also eccentric rotation inside the female stator, fluid enters and leaves the central male/female rotor stator cavities through the inner and outer feeder pathways on the cylindrical male/female rotor ends, or by direct feed into the cavities in pumps or motors when the bearings are not used on the outlet side of the inner male stator and inlet side of the drive head male and female rotor, but still retaining the flow pathways on the drive head shaft rotor end.

Multi phase fluids can also be pumped by the use of twin outer left hand and right hand female internal helix stators allowing for centre fluid chamber and outer fluid feed chambers, the centre male left hand and right hand exterior helix stator with centre flow recess, the male stator is fixed to the pump casing at the bottom end and held in position in the main rotor by bearings so that the rotor and the flexible joint rotate around the inner male fixed stator. The only moving part is the male/female internal helix cylindrical rotor with left hand and right hand helix, with out fluid pathways to feed the central rotors, stators through the cavities formed by the contra rotating helix allowing fluid to be driven to the centre outlet pump chamber. The cylindrical male/female contra rotating helix rotor has central fluid pathways to allow the fluid to enter the centre outlet chamber with the fluid from the outer male

rotors/stators, the outer cylindrical rotors and fixed male stators with one less lobe than the outer stator and inner rotor both move around the inside of the stator/rotors. This combined geometry sequentially seals the flow chambers through which the fluid moves axially, the configuration of the rotors and stators contra rotating act as integral opposing reducing gears and opposing power generation units which delivers high pump volume with high pressure by the contra rotating multi-helix rotors and stators.

The ultralobe cavity trirotor positive displacement pump has only one moving part, that of the male/female multi-helix drive head rotor with male external helix rotor and female internal helix rotor, the outer female internal helix stators and the fixed male external helix stator. The female and male stators can be precision moulded from durable corrosion resistant synthetic elastomer which is permanently bonded to a steel housing.

The drive head cylindrical rotor internal helix is precision moulded and permanently bonded to the drive head rotor but other methods may be used by those skilled in the art, with the external helix bonded to the central male fixed stator. This type of design cannot gas lock so pumping free gas is ideal for this system. It is also ideal for pumping in adverse conditions such as sand, gypsum, salt, parafin, wax, gas and high viscosity crude.

Multi-helix or 1/2 lobe rotors/stators are covered within the invention.

With the ultralobe cavity trirotor motor rotational power is created when fluid is pumped through the multi-helix which operates on the Moineau principle rotor/stator configuration multi stage progressive cavities allowing low and high speeds with high torque with the use of internal and external multi-helix rotors/stators allowing a continuous flow of pressurised fluid to pass through the cavities. Special types of rubber compounds can be used thereby preventing abrasive wear and allowing the use of wear resistant materials to eliminate erosive wear on the internal external rotor/stator system.

The male stator and female stator is fitted with a constant velocity flexible connecting rod assembly. The male/female rotor/stator can also be contra rotating.

Figure 47 shows a radial cross-section of a multiphase flow type ultralobe cavity trirotor pump showing:-

1. Shows pump casing.
2. Shows fluid transfer chamber.
3. Shows pump chamber.
4. Shows pump end cover.
5. Shows pump end drive cover.
7. Shows female right hand fixed internal helix stator.
8. Shows female left hand fixed internal helix stator.

9. Shows left hand and right hand internal and external helix rotor drive shaft.
11. Shows constant velocity flexible joint with flow pathways for fluid.
12. Shows constant velocity flexible joint with flow pathways for fluid.
13. Shows centre flow pathways for fluid.
14. Shows male stator bearing housing.
15. Shows male stator fixed drive bearing housing bottom.
19. Shows pump end cover fixing studs and nuts.
20. Shows bearing housing.
21. Shows male and female rotor bearing drive.
22. Shows inlet port.
23. Shows outlet port.
24. Shows external cavities.
25. Shows internal cavities.
28. Shows left and right hand external helix fixed male stator.
29. Shows male stator fixing point.
30. Shows joint for male and female internal/external helix cylindrical drive head rotor.

Claims

1. A method of extracting fluid from a reservoir of said fluid comprising the use of geothermal energy.
2. A method as claimed in claim 1, comprising the drilling of a well into an area of geothermal energy so as to enable release of the geothermal energy into the fluid reservoir.
3. A method as claimed in claim 2, comprising the step of passing a liquid down the well so as to rupture rock formations between the area of geothermal energy and the fluid reservoir.
4. A method as claimed in claim 2, comprising the drilling of a well between the area of geothermal energy and the fluid reservoir.
5. A method as claimed in claim 2, comprising drilling the well with a downward bore and a subsequent upward bore.
6. A method as claimed in claim 5, comprising drilling the well with a generally horizontal bore extending from the upward bore.
7. A method as claimed in claim 2, comprising drilling the well with a downward bore and one or more generally horizontal bores extending from the downward bore.
8. A method as claimed in claim 7, comprising drilling the well with a downward bore extending from the said generally horizontal bore.
9. A method as claimed in claim 1, comprising the drilling of a well through an area of geothermal energy, extending the well beyond the area of geothermal energy into the said reservoir.
10. A method as claimed in claim 1, comprising the drilling of a well through a reservoir of said fluid, extending the well beyond the fluid reservoir into an area of geothermal energy and subsequently blocking the well above the fluid reservoir.

11. A method as claimed in claim 10, comprising the use of a non-return valve to block the well but permit subsequent down well injection of fluids.
12. A method of extracting fluid from a reservoir of said fluid comprising the use of geothermal energy and the drilling of a configuration of wells as shown in any one of figures 1 to 15 of the accompanying drawings inclusive.
13. A method of extracting fluid from a reservoir of said fluid comprising the use of geothermal energy and any combination of any of the features described herein with reference to figures 1 to 15 of the accompanying drawings inclusive.
14. A method of extracting geothermal energy from the ground comprising the drilling of a configuration of wells as shown in figure 14A of the accompanying drawings alone or as shown in figures 14A and 15A of the accompanying drawings in combination.
15. A tool for use in the drilling of wells, comprising a tool body and a plurality of segments movable with respect to the body in a radial direction with respect to the well bore.
16. A tool as claimed in claim 15, comprising a control unit which controls movement of the segments in accordance with control signals transmitted to the said unit by means of a fluid.
17. A tool as claimed in claim 15 or 16, wherein the segments are provided with cutting surfaces such that the tool can be used as a reamer.
18. A tool as claimed in any of claims 15 to 17, wherein the segments are releasable so that different segments can be fitted to the tool body whereby different stabilising or reaming surfaces can be presented to the well bore.
19. A tool as claimed in claim 15, further comprising in any combination any of the features shown in figures 16 to 20 of the accompanying drawings.
20. A tool for use in the drilling of wells, comprising a main body, a calliper body, a plurality of segments movable with respect to the calliper body in a radial direction with respect to the well bore, and a mechanism for moving the main body with respect to the calliper body.

21. A tool as claimed in claim 20, wherein the said mechanism comprises two toggle and latch units which control the flow of operating fluid to respective chambers for effecting the said movement of the main body.

22. A tool as claimed in claim 20, further comprising in any combination any of the features shown in figures 21 to 26 inclusive of the accompanying drawings.

23. A tool for use in the drilling of wells, comprising a body having first and second portions coupled by a joint wherein the joint is adapted to be controlled by fluid pressure so as to change the angle of inclination of the said body portions relative to each other.

24. A tool as claimed in claim 23, wherein the body further comprises a third portion coupled to the said second portion by a second joint such that the second portion is coupled between the first and the third portions with the second joint being adapted to be controlled by fluid pressure so as to change the angle of inclination of the second and third body portions relative to each other.

25. A tool as claimed in claim 23 or 24 including a positive displacement fluid operated motor.

26. A tool as claimed in claim 23, further comprising in any combination any of the features shown in figures 27 to 43 inclusive of the accompanying drawings.

27. Any one of: an adjustable reamer/stabiliser, a thrust calliper, a positive displacement drilling motor, a trajectory control unit, an ultalobe cavity trirotor positive displacement pump/motor, a trirotor mud drilling motor and a compensating underreamer tool as hereinbefore described.

28. A tool for use in the drilling of wells, comprising a tool body and a plurality of segments movable with respect to the body with each segment having a cutting edge at one end thereof and with movement of the segments being such that the said ends move in a radial direction with respect to the well bore.

29. A tool as claimed in claim 28, further comprising in any combination any of the features shown in figure 44 of the accompanying drawings.

30. A pump/motor for use in the drilling of wells, comprising a housing having an internal helix, a fixed female external helix outer stator with an internal helix and a fixed male helix.

31. A drilling motor for use in the drilling of wells, comprising an epitrochoidal rotary cylinder and a trirotor.

FIG.1

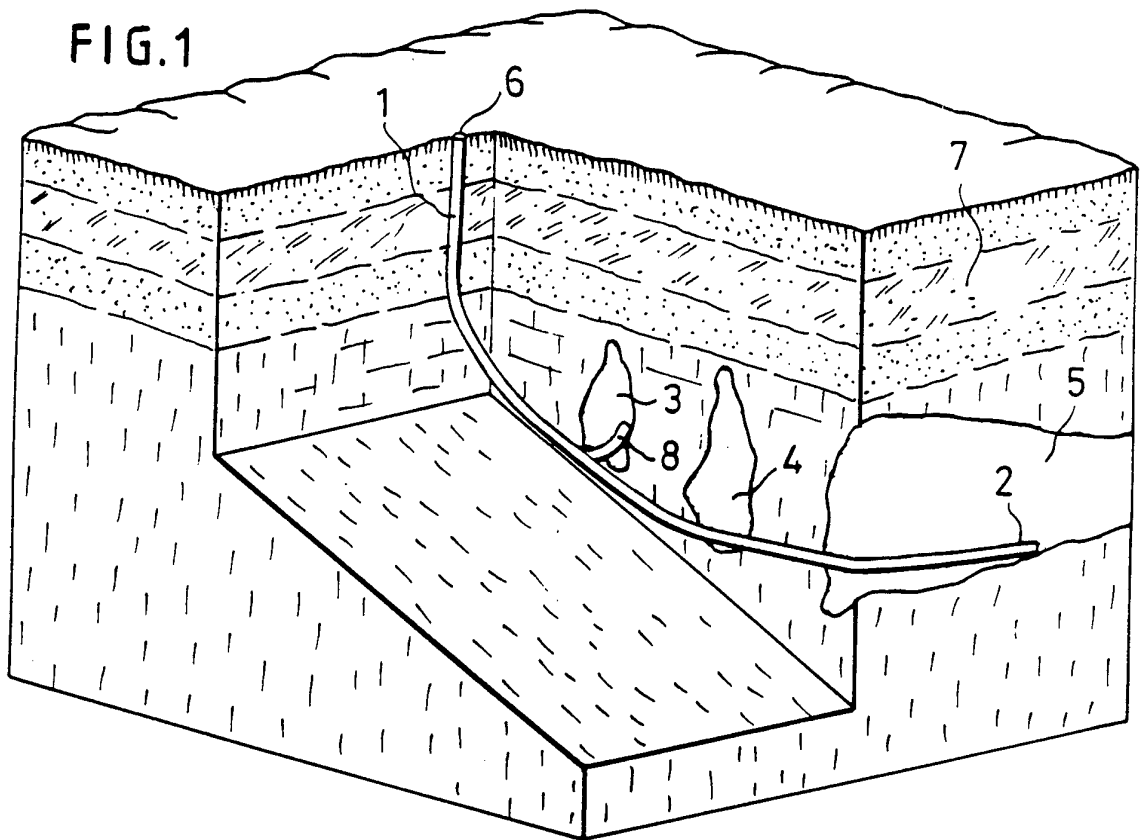

FIG.2

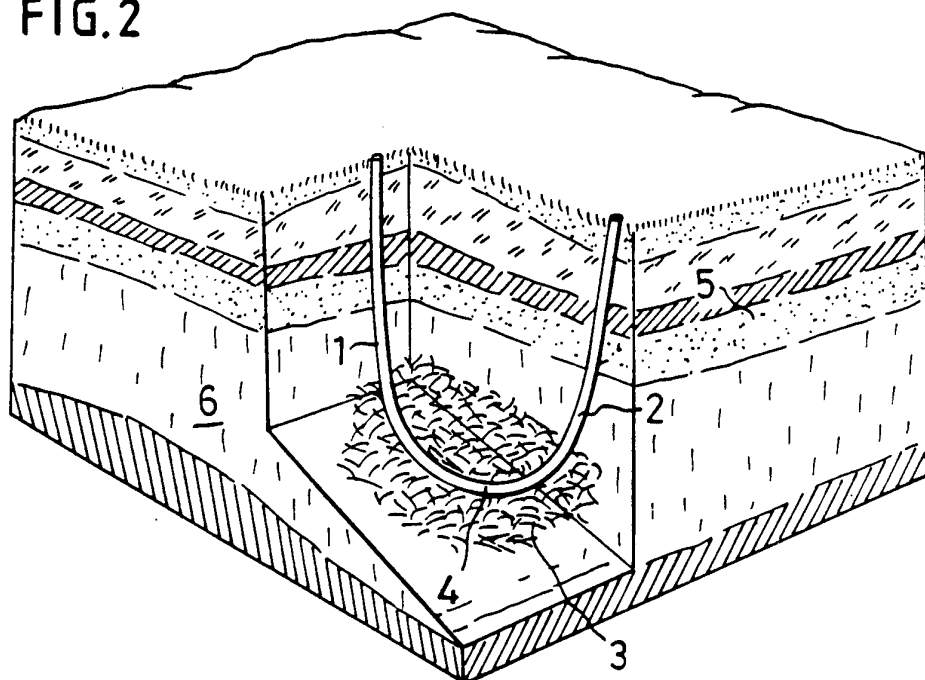

FIG.3

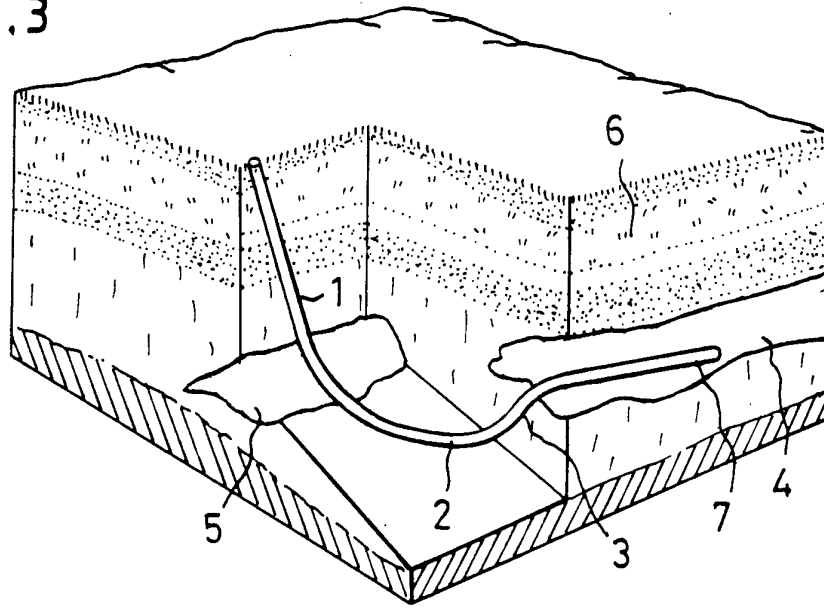

FIG.4

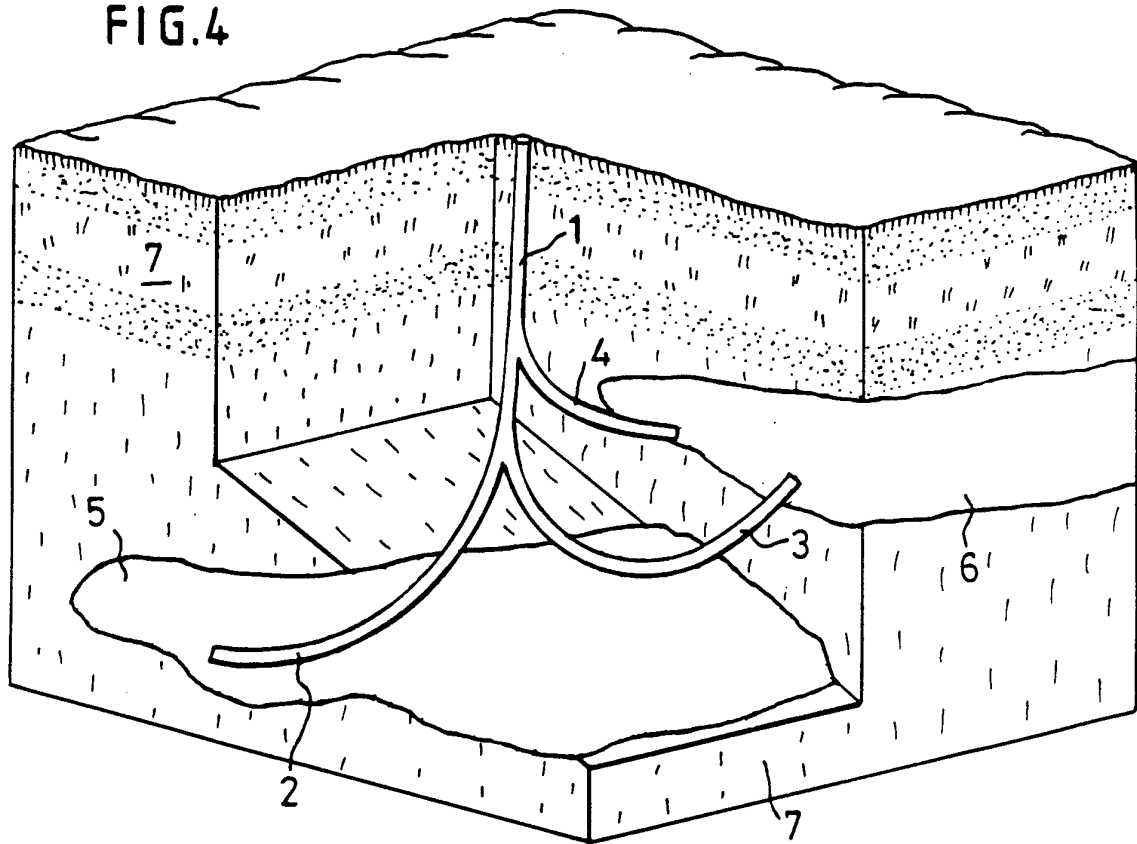

FIG. 5

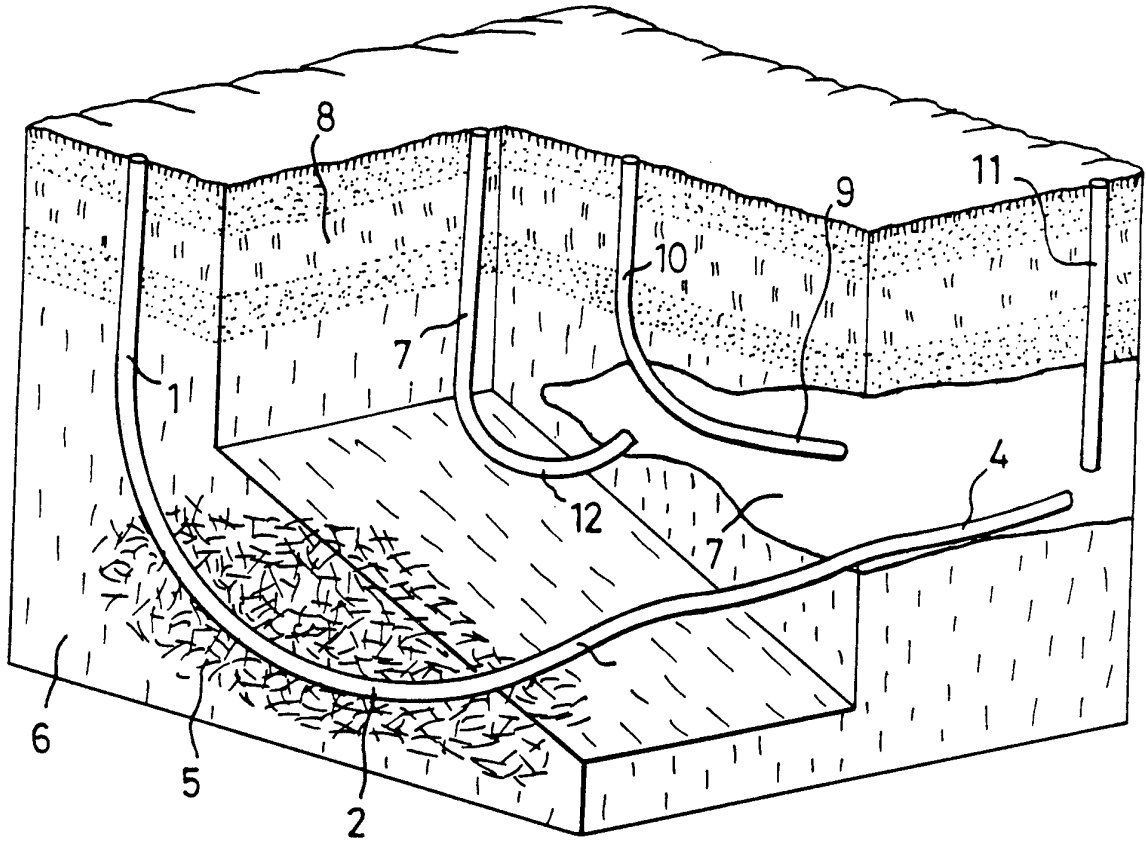
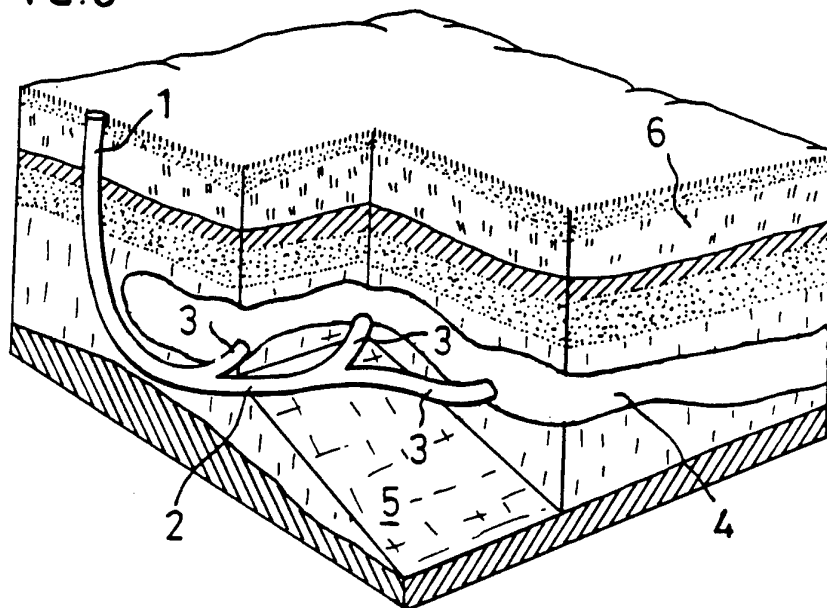

FIG. 6



4/22

FIG. 7

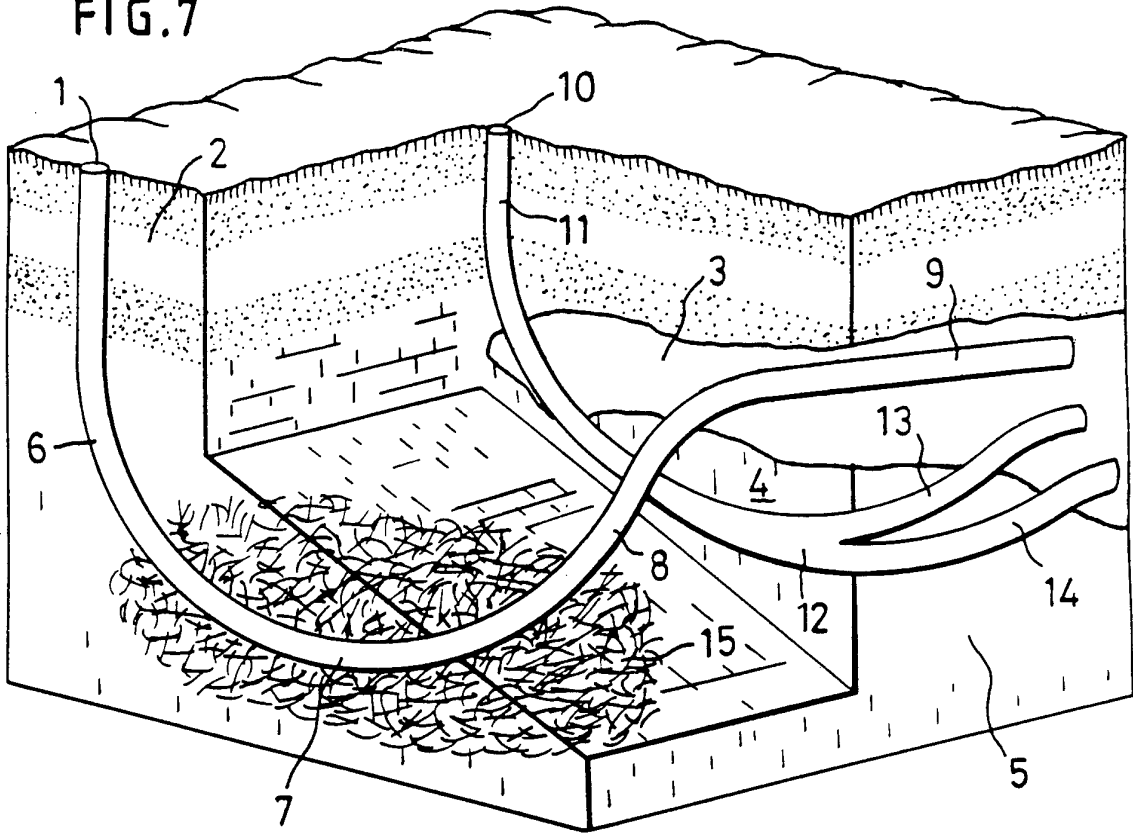
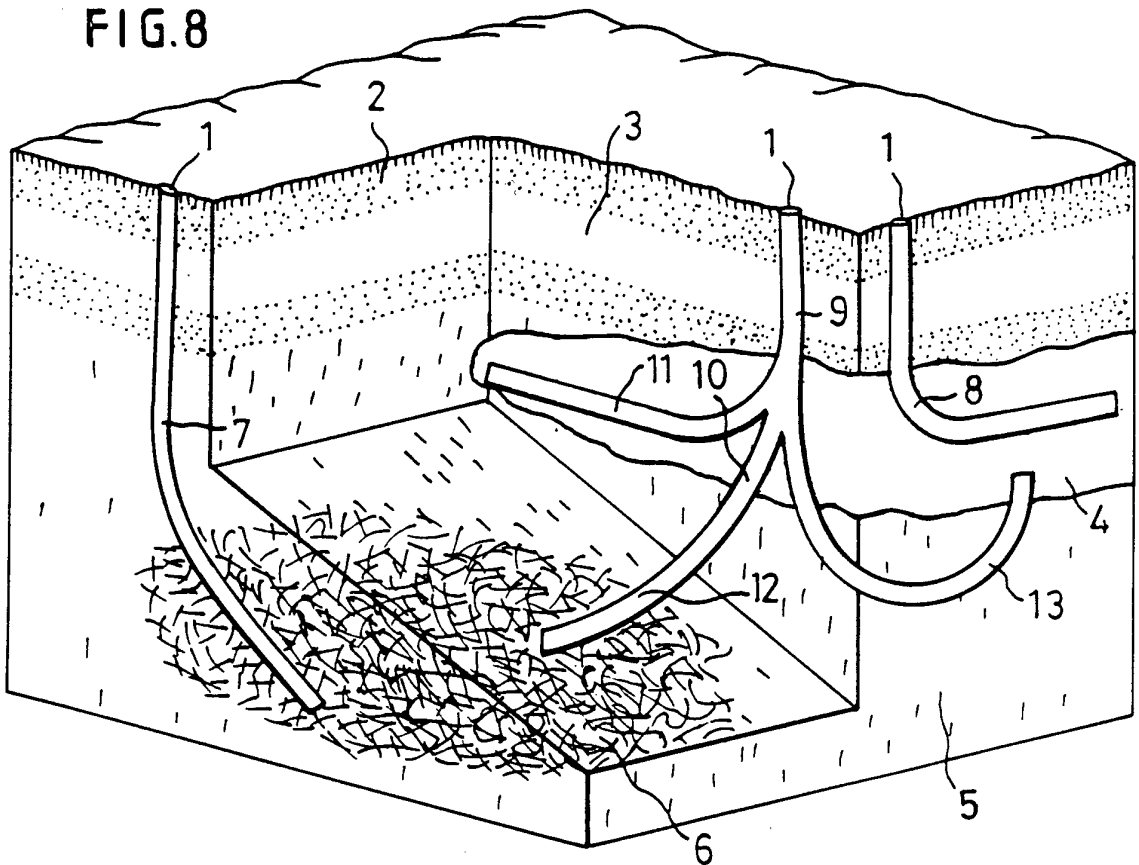

FIG. 8



5/22

FIG.9

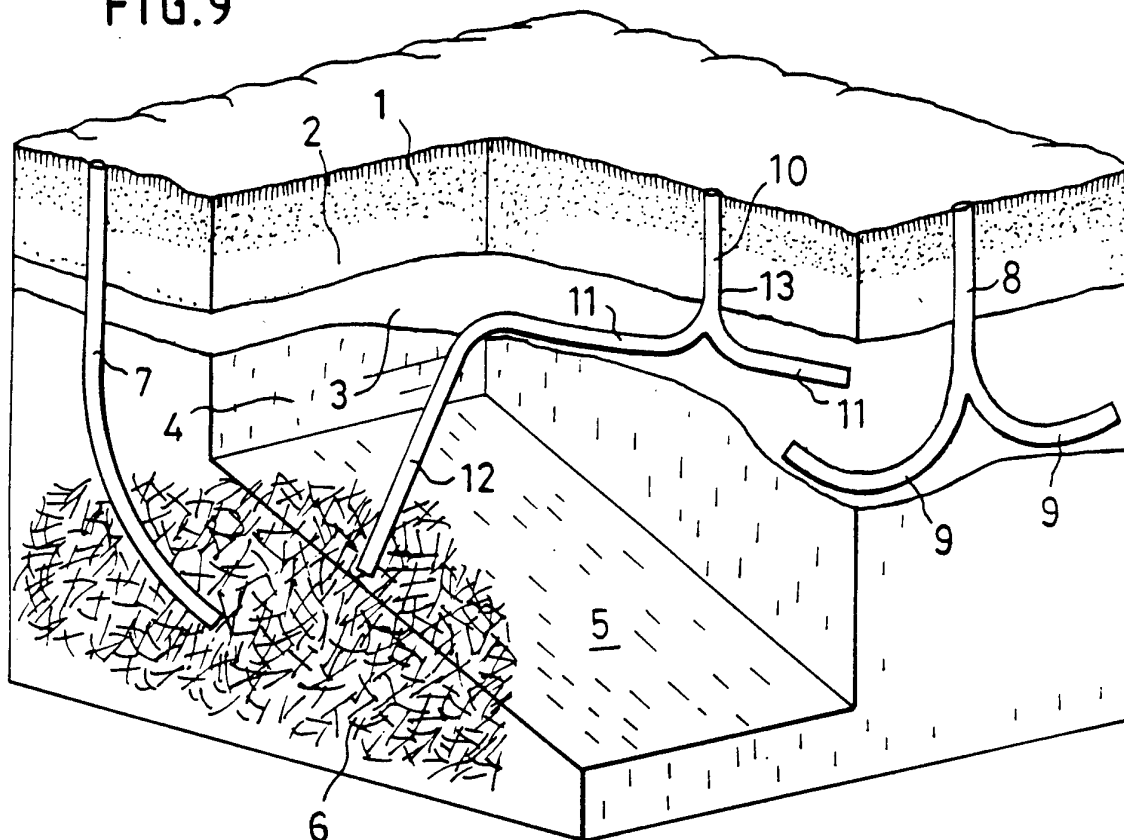

FIG.10

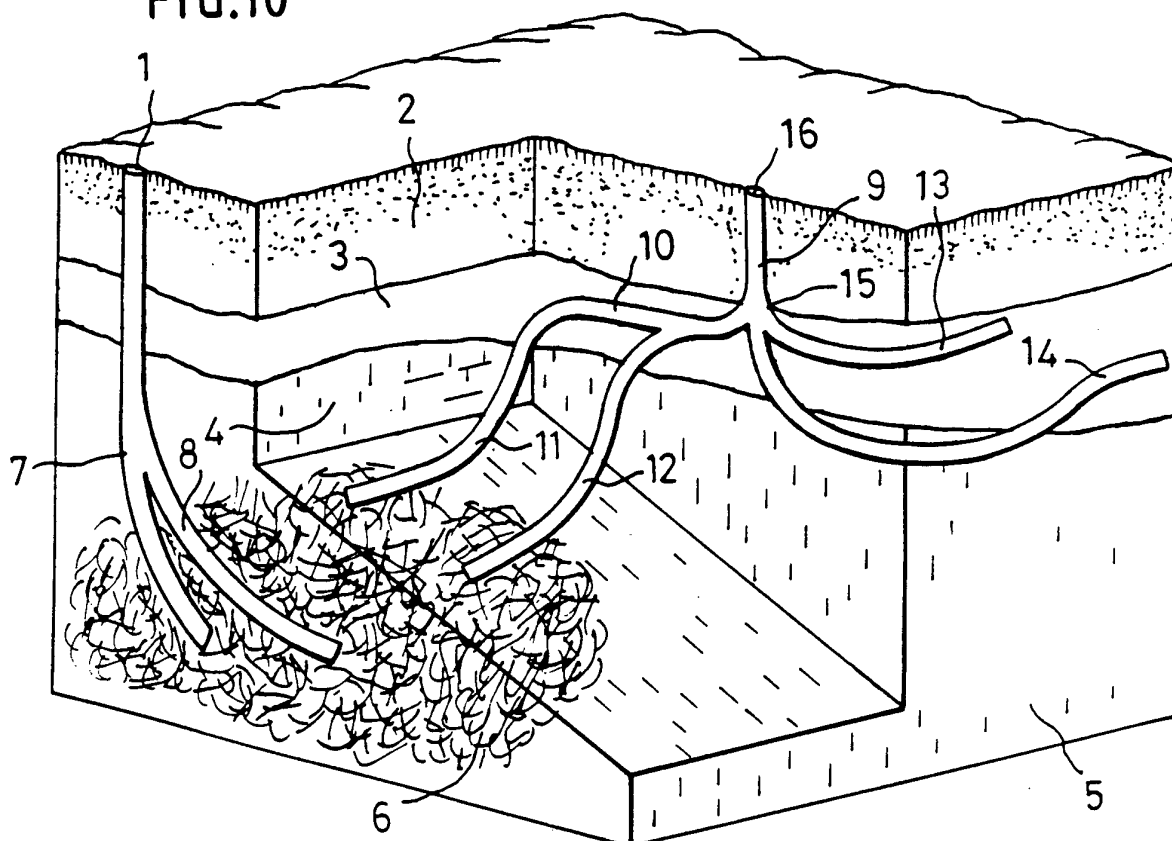

FIG.11

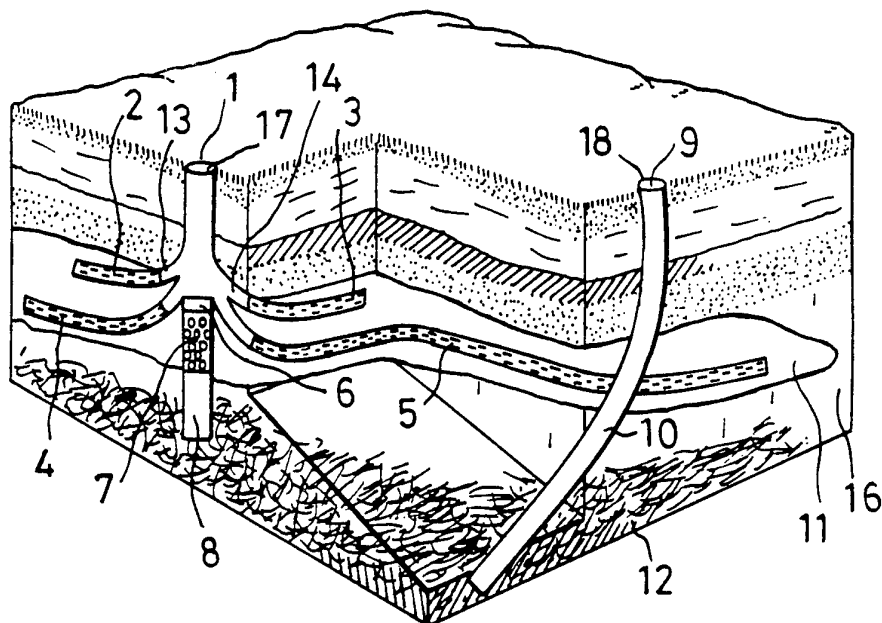

FIG.12

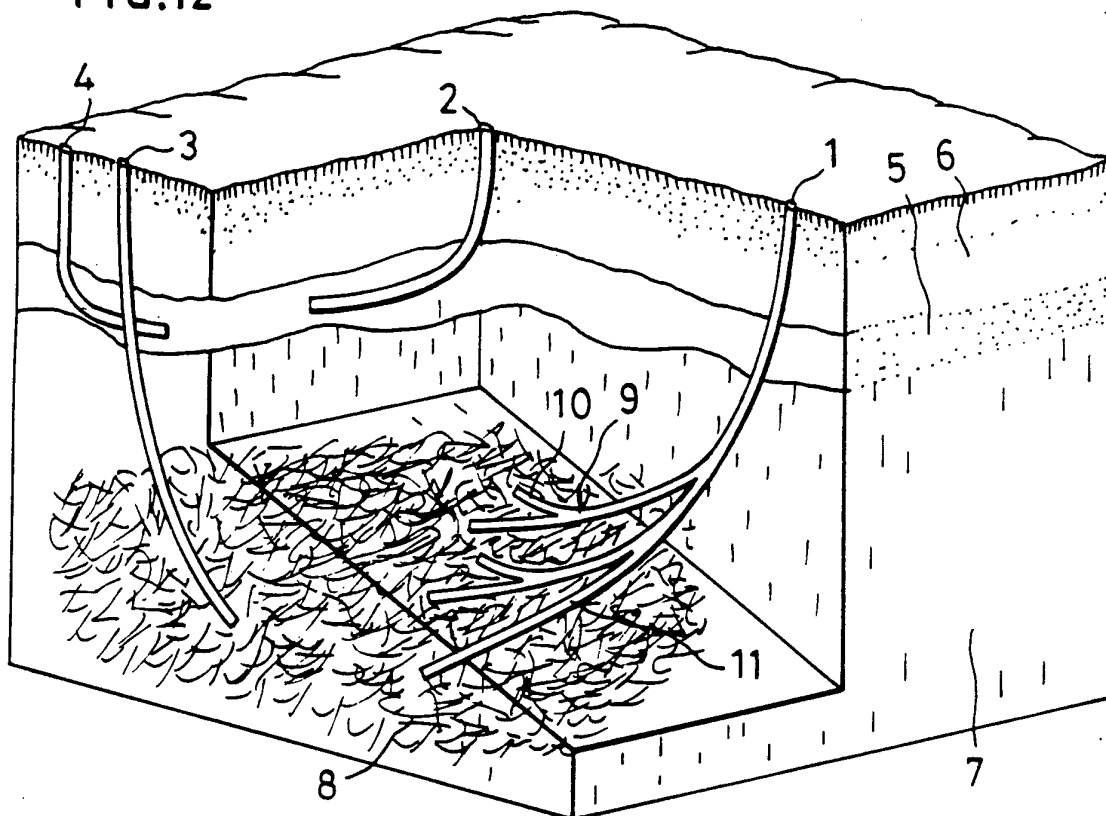
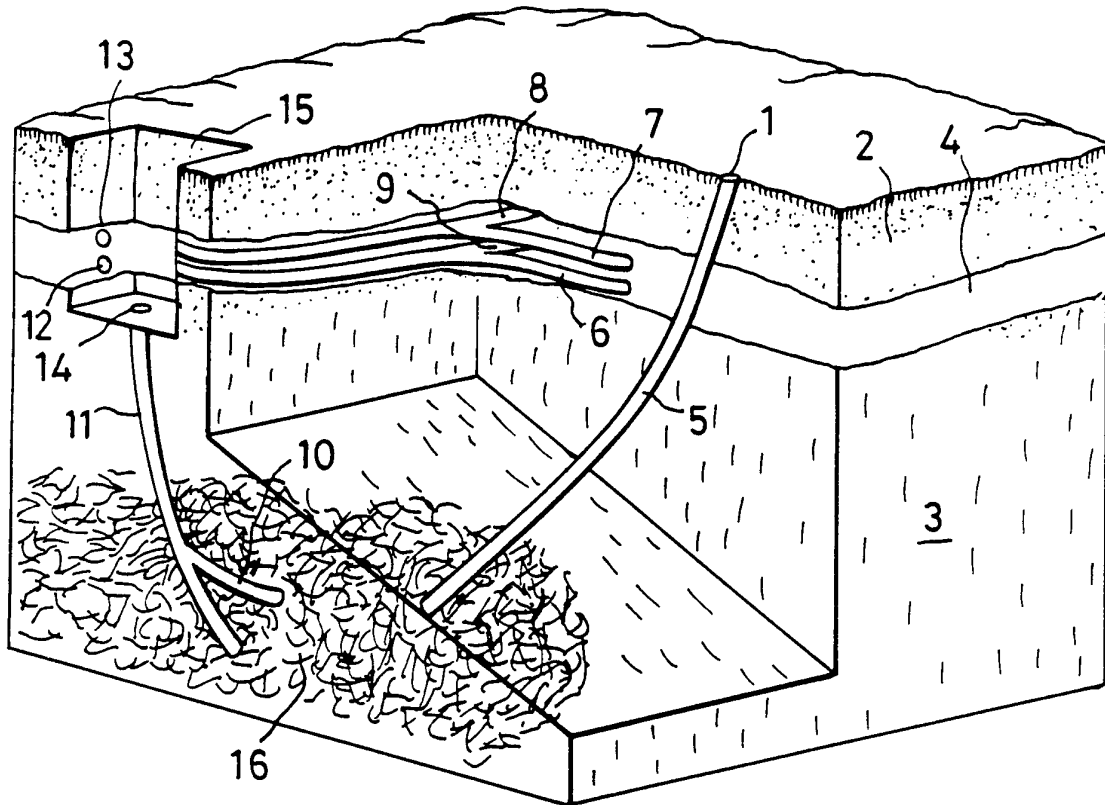

FIG.13



8/22

FIG.14 A

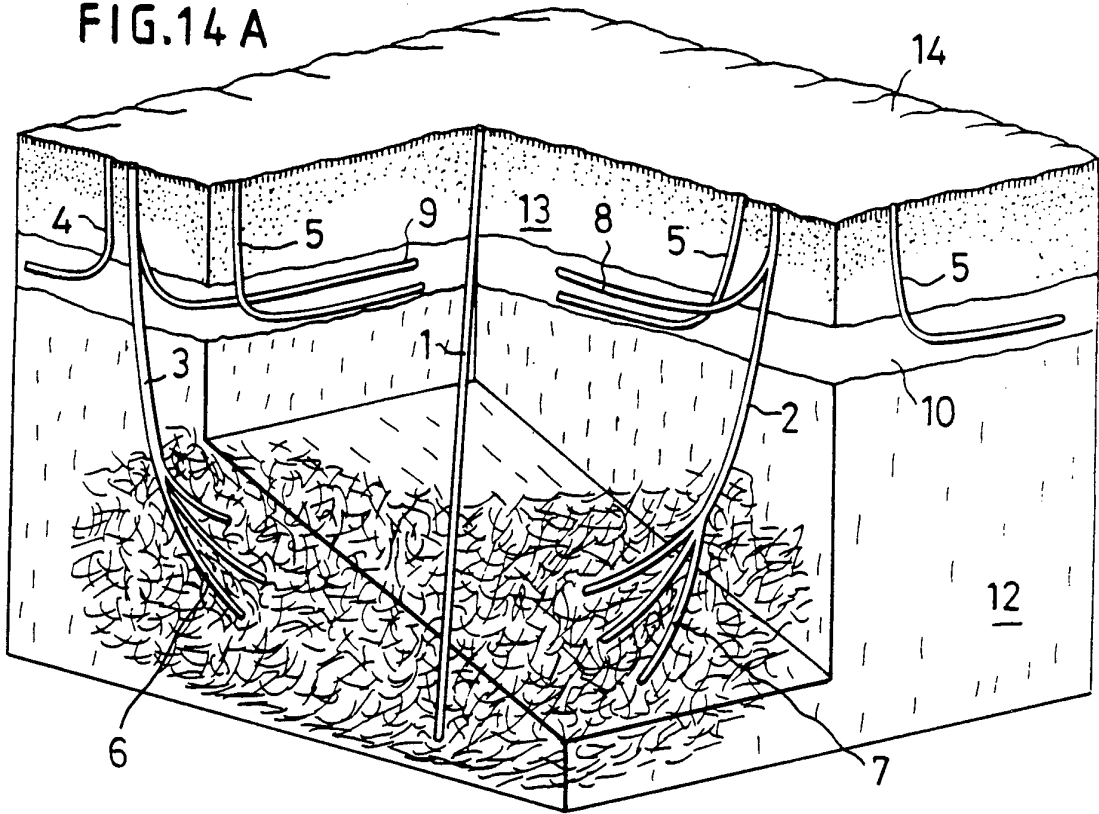
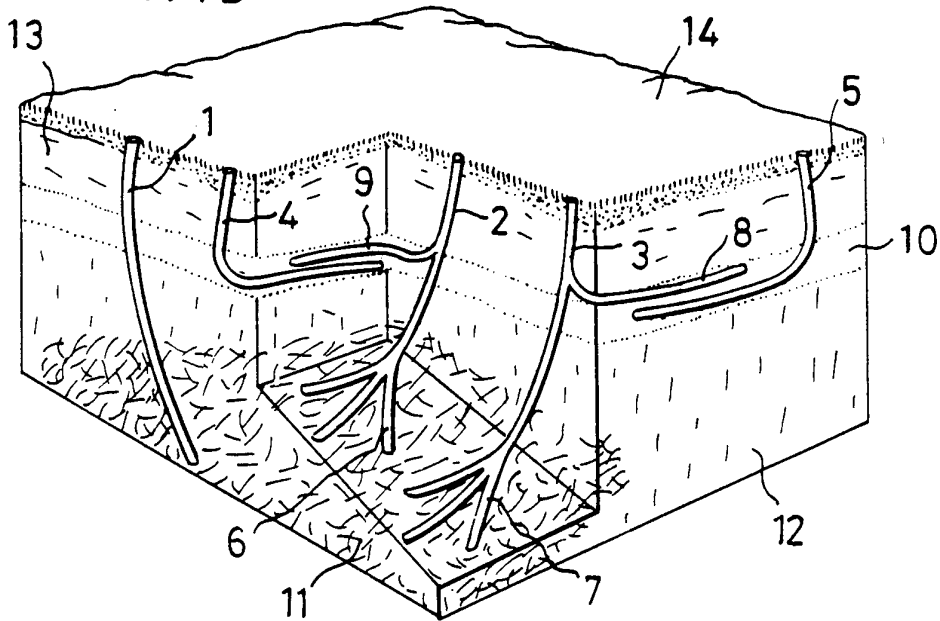

FIG.14 B



9/22

ORIGINAL INJECTION WELL TURNED INTO PRODUCTION WELL
AFTER FRACING OPERATION WITH TRILATERAL SIDE
TRACKS FOR MAXIMUM PRODUCTION

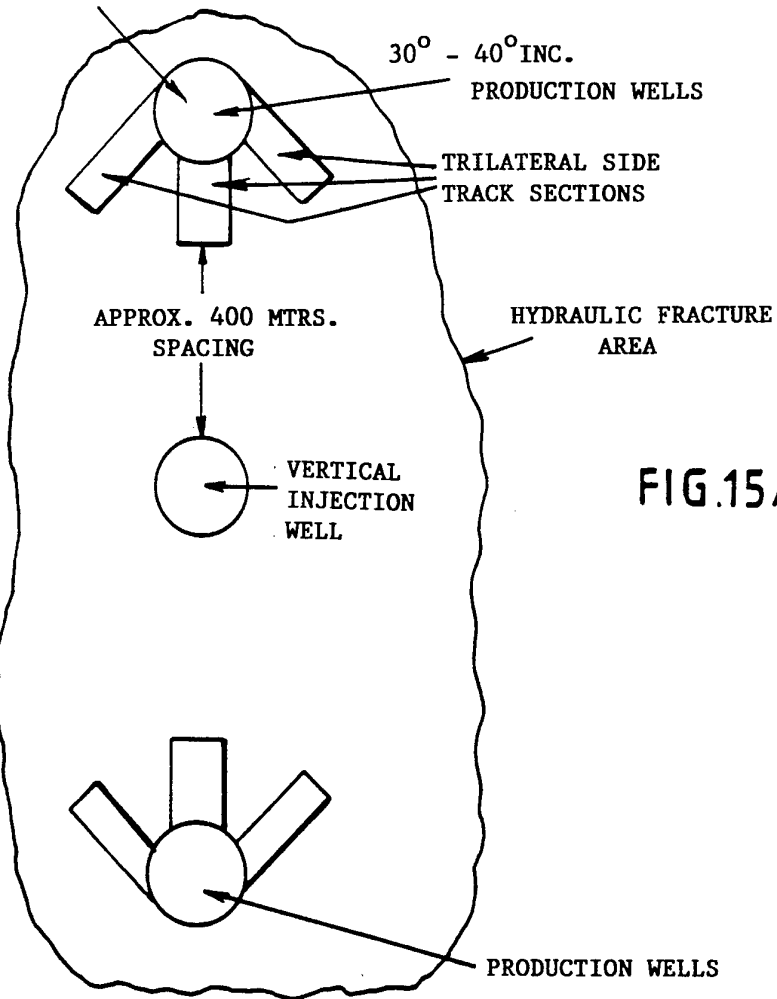

FIG.15A

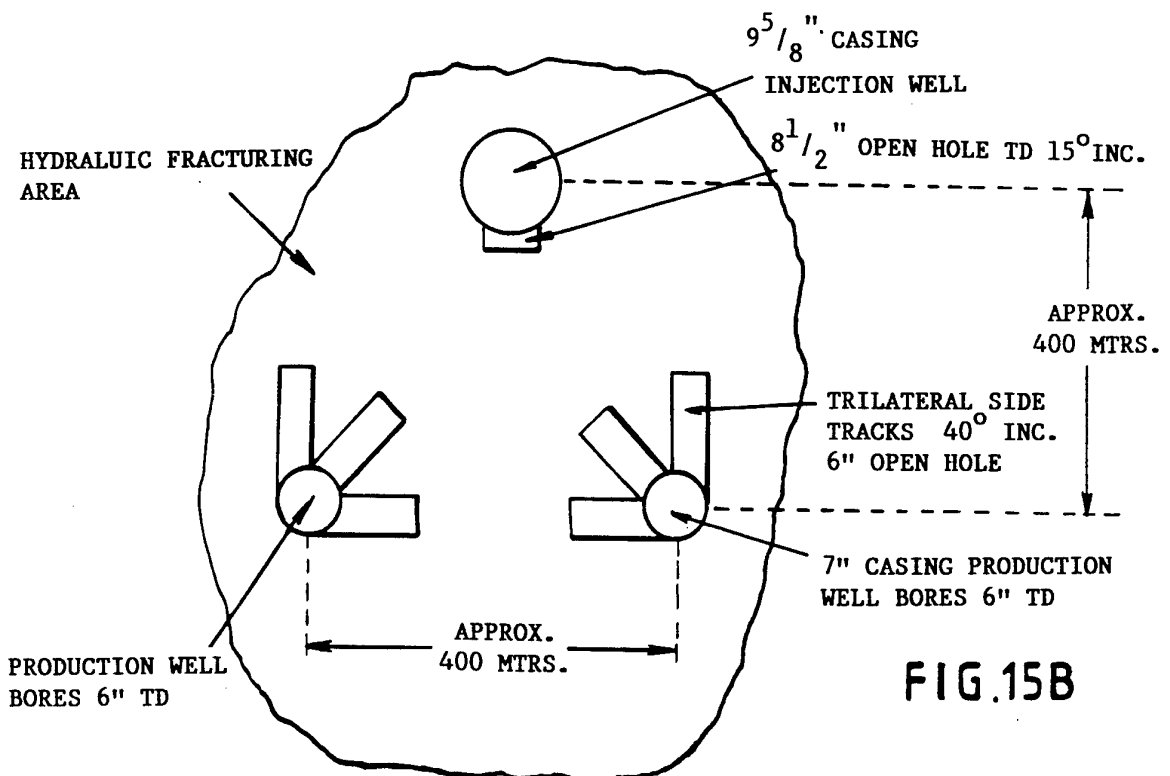

FIG.15B

10/22

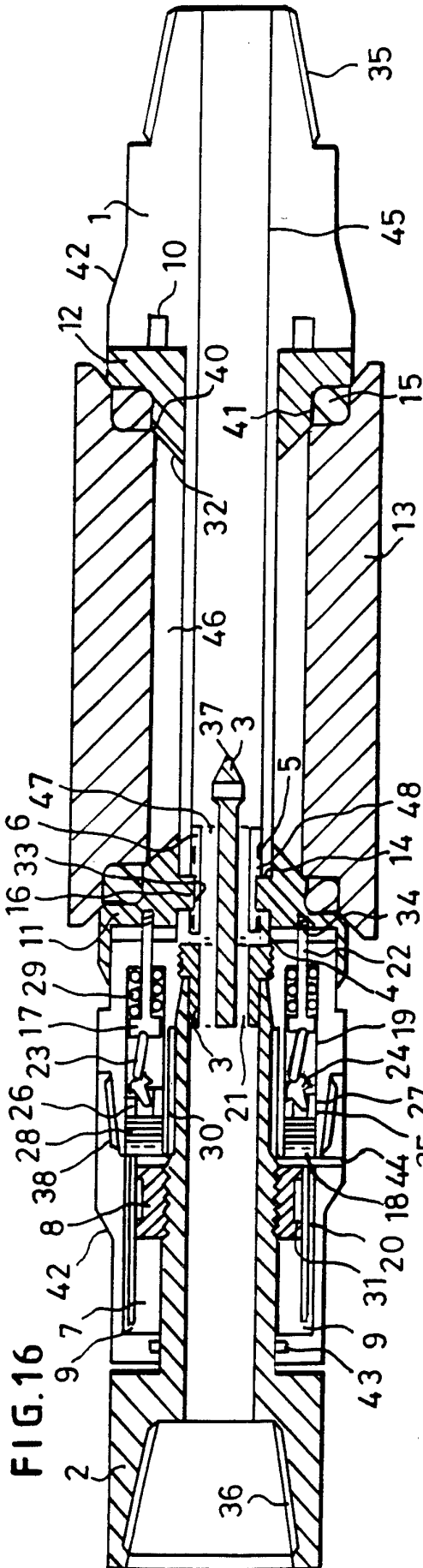

FIG. 16

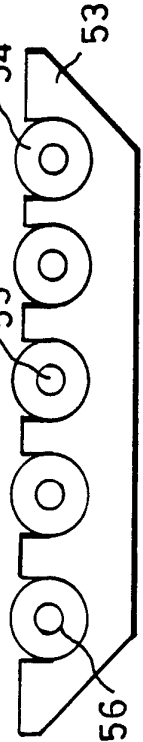

FIG. 18

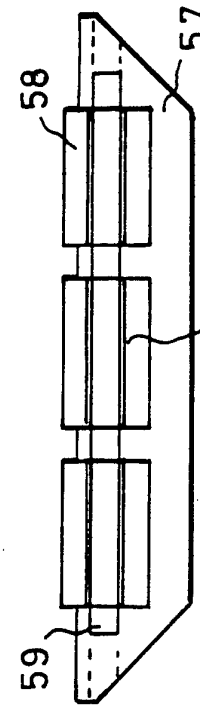

FIG. 19

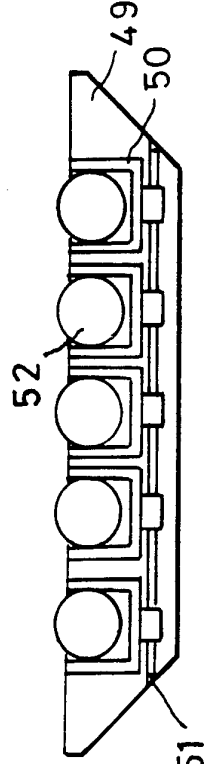

FIG. 20

11/22

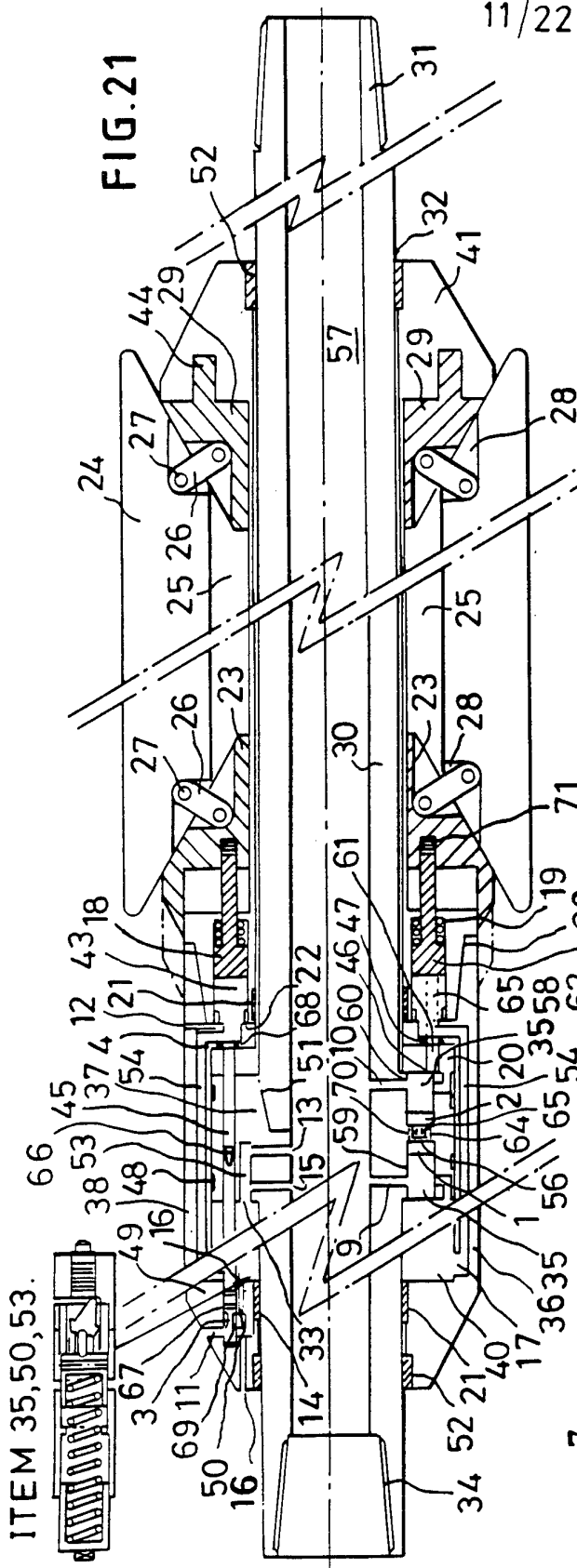

FIG. 21

ITEM 35, 50, 53.

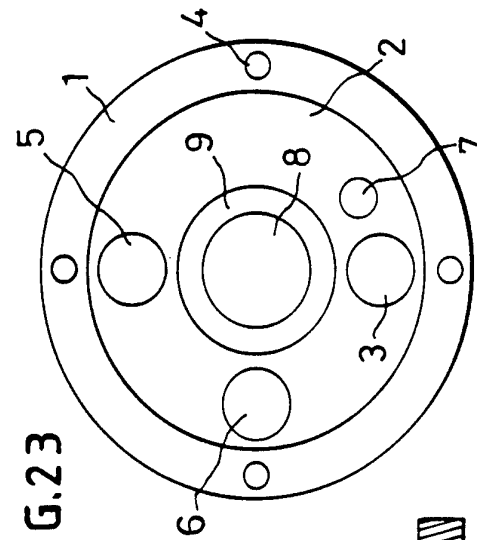

FIG. 23

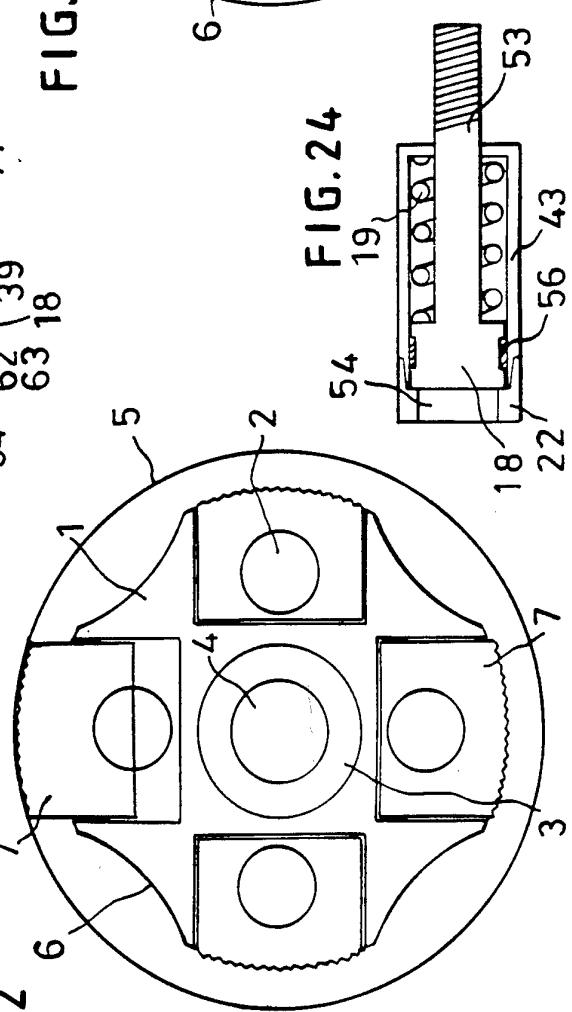

FIG. 22

FIG. 24

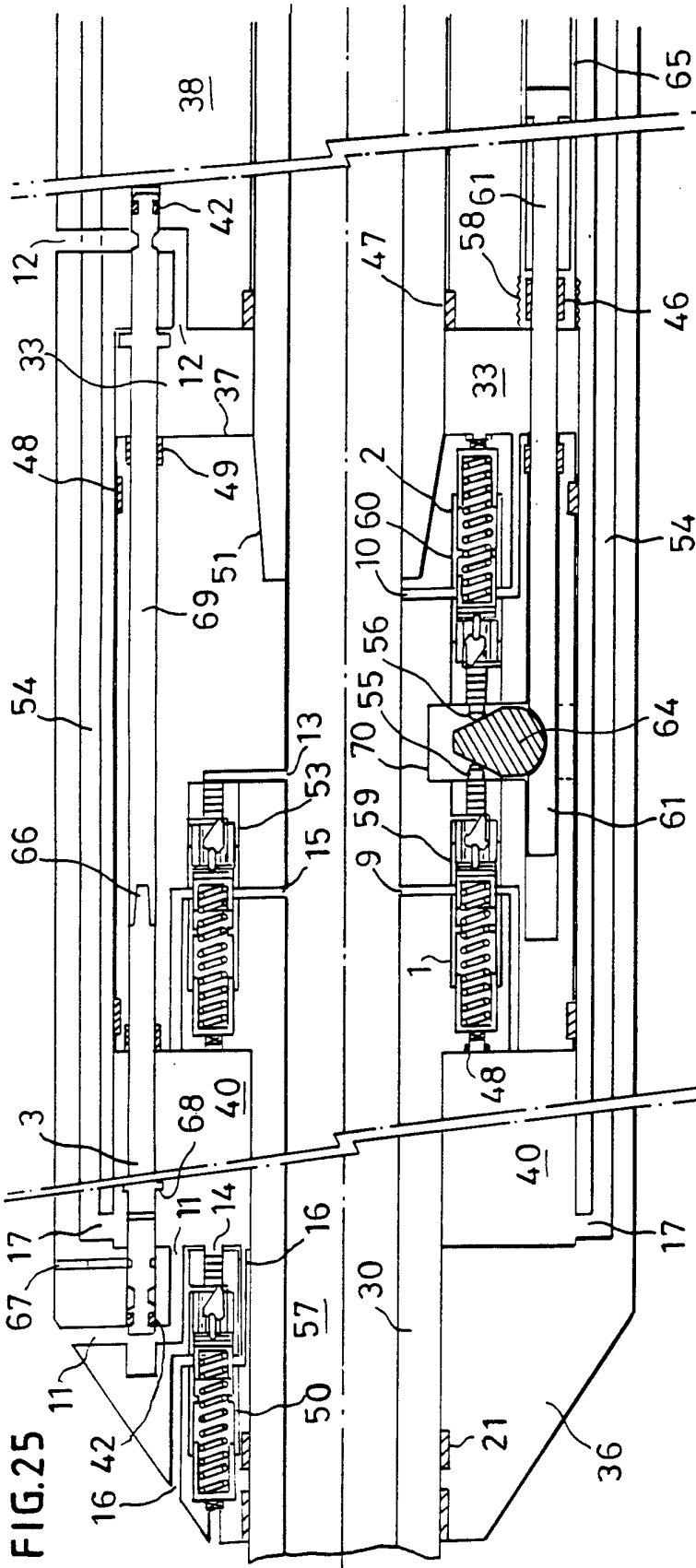

FIG. 25

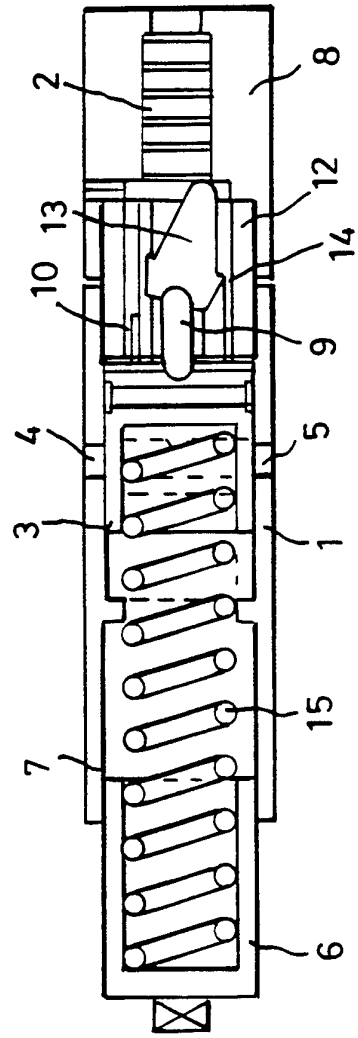
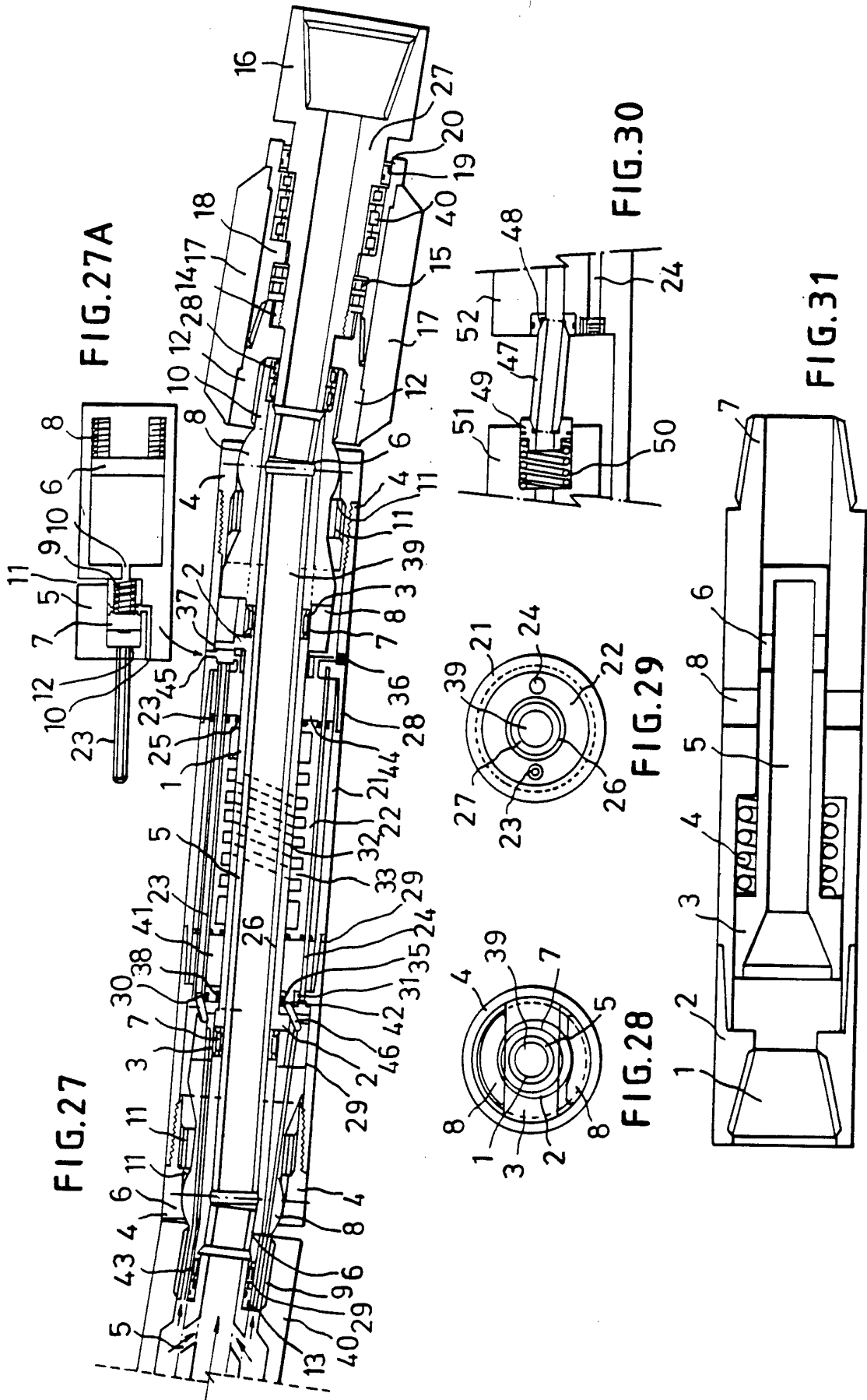

FIG. 26



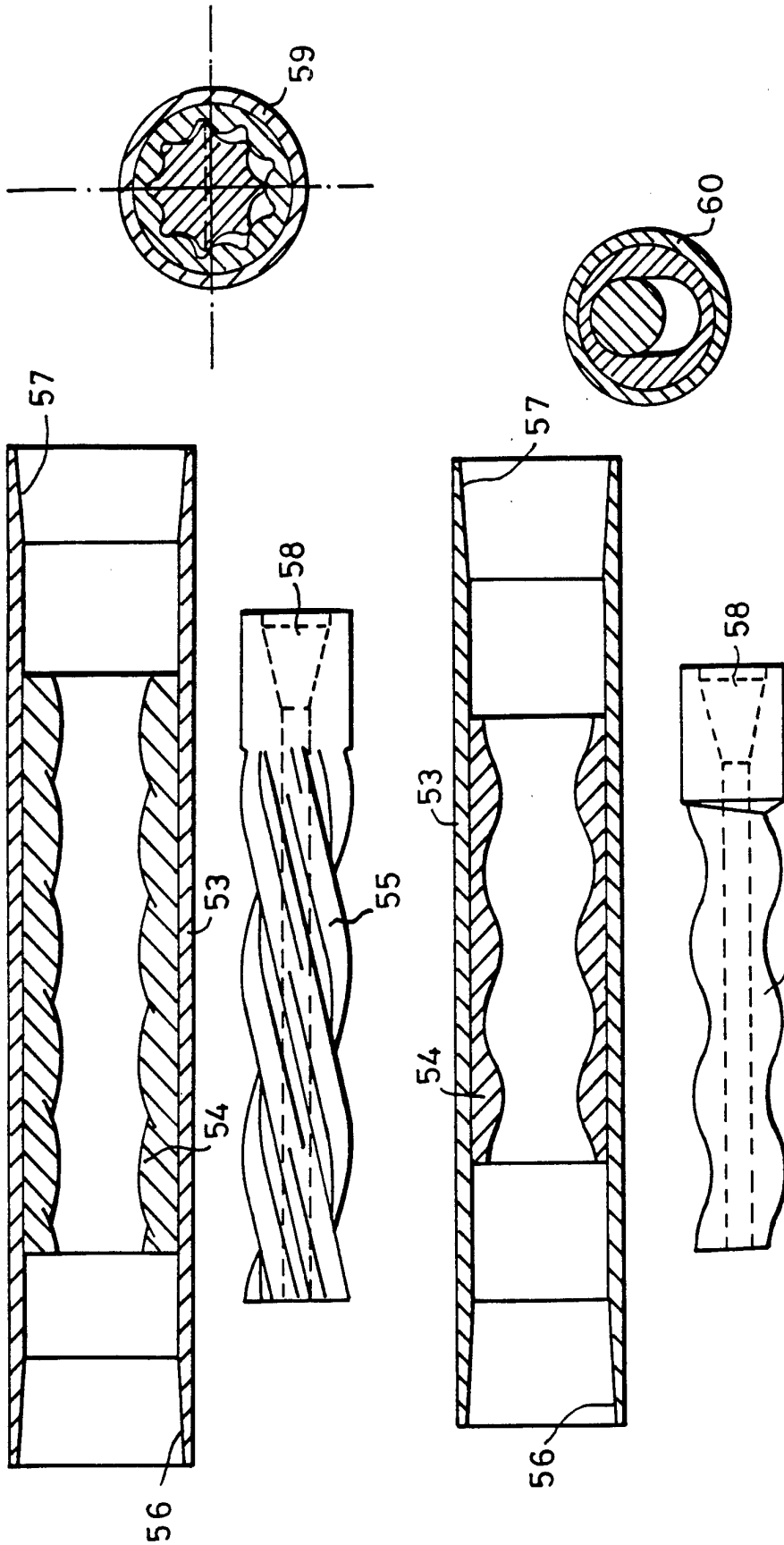

FIG 32

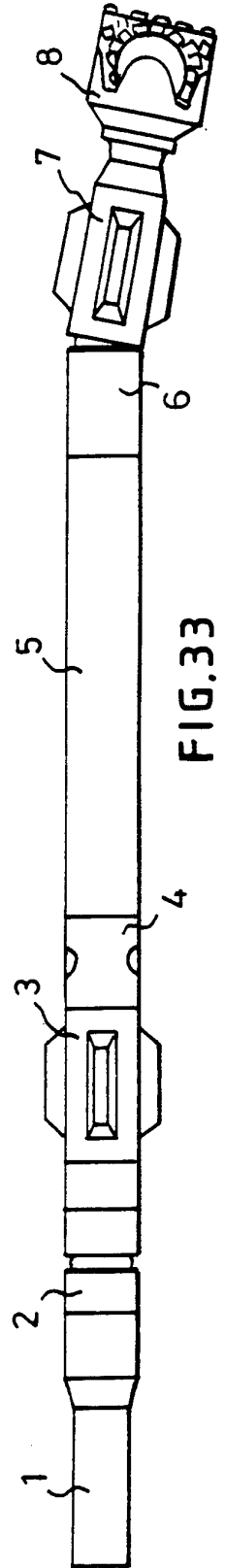

FIG.33

15/22

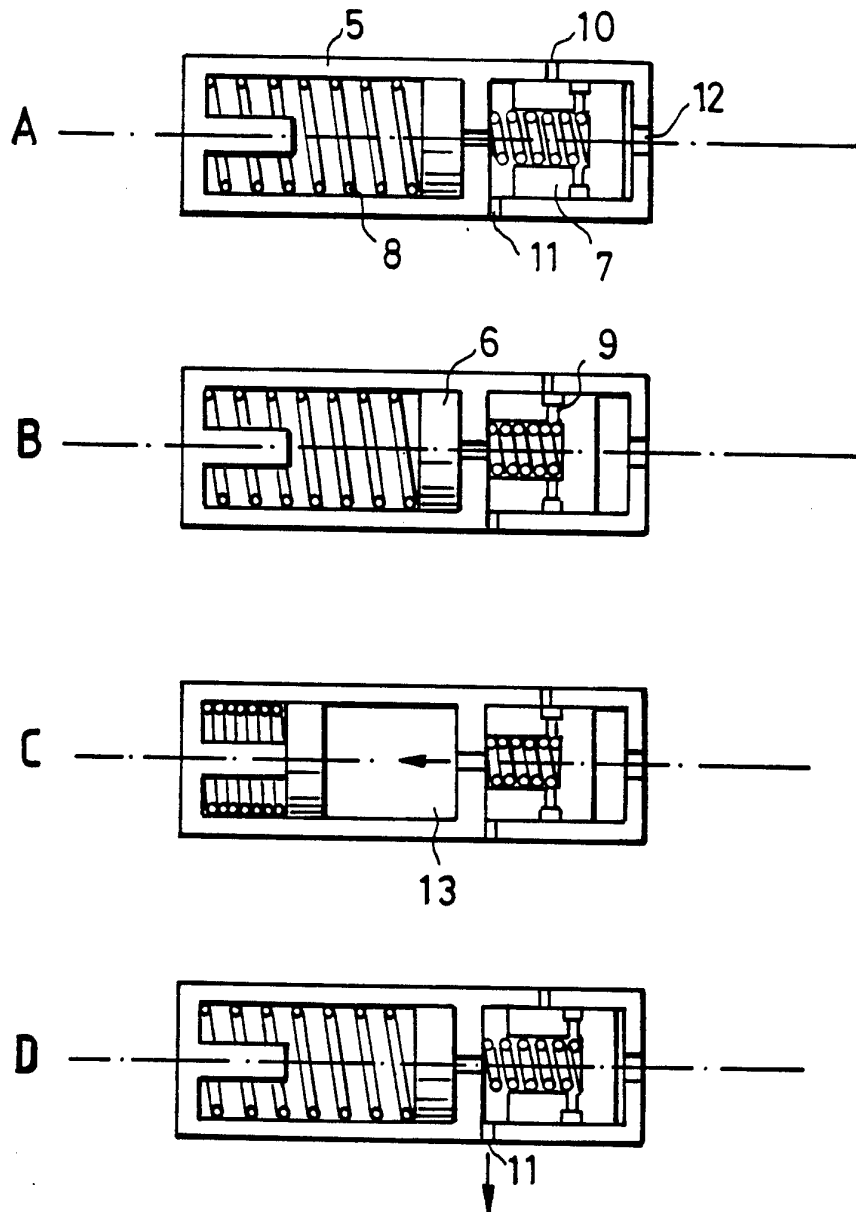

FIG. 34

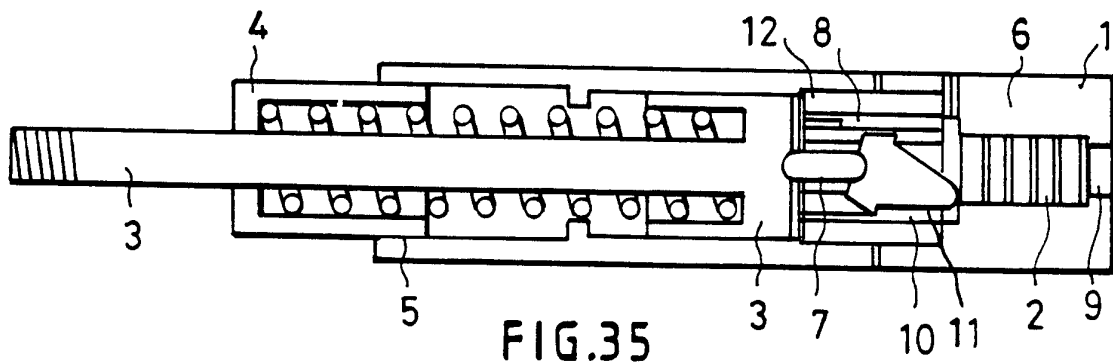
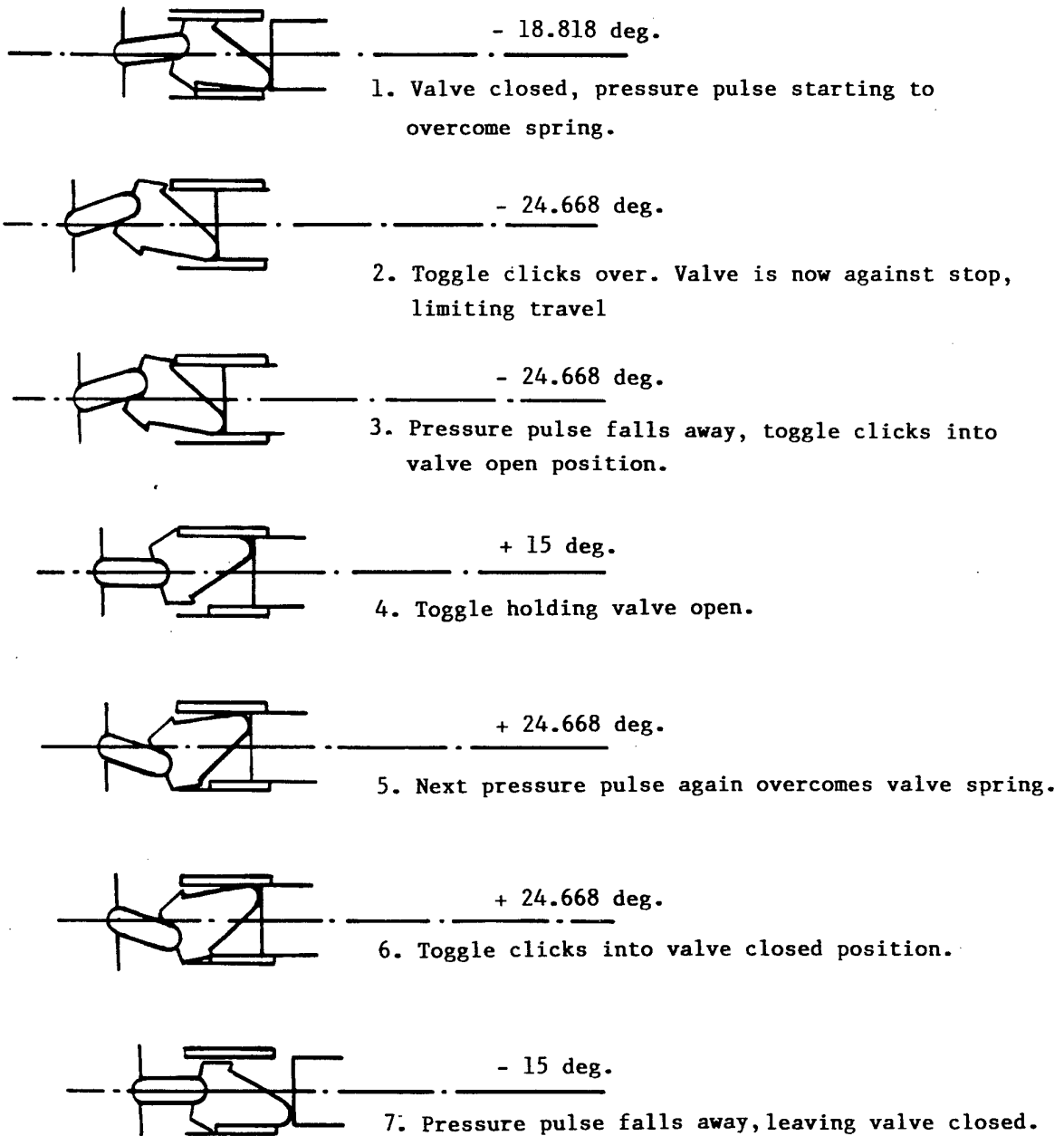

FIG. 35

16/22

FIG.36



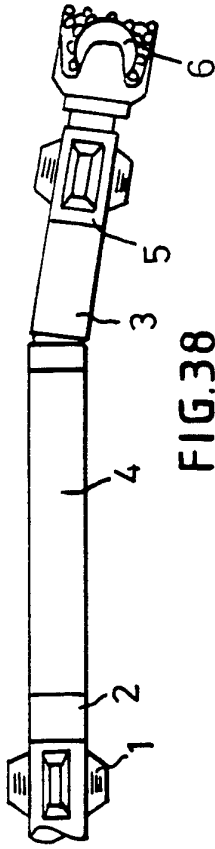

FIG. 37

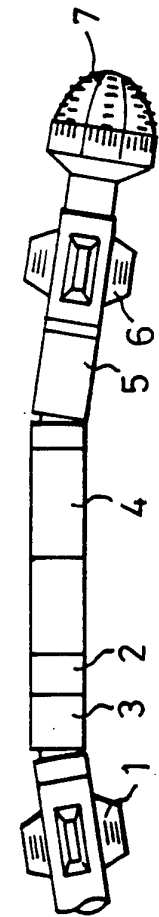

FIG. 38

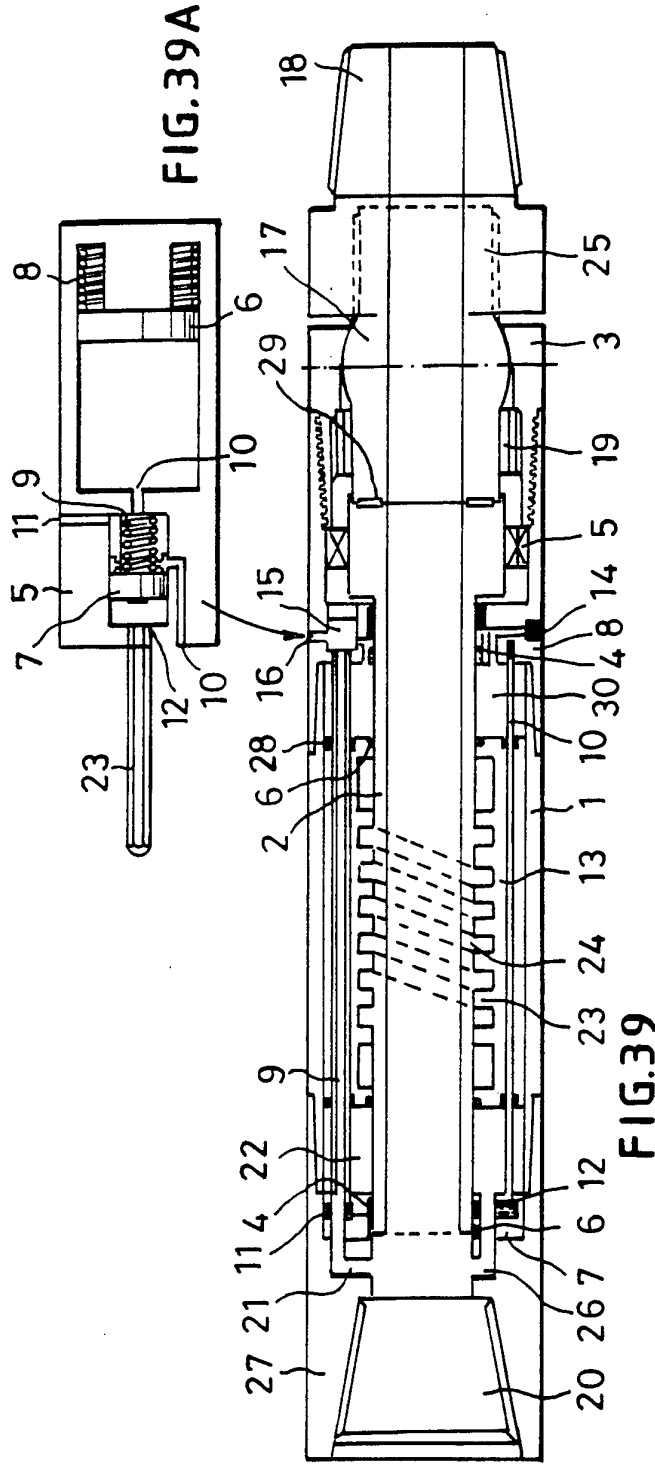

FIG. 39A

FIG. 39

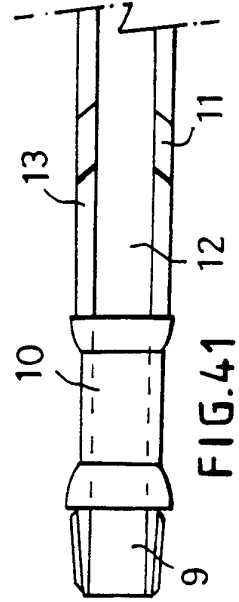

FIG. 40

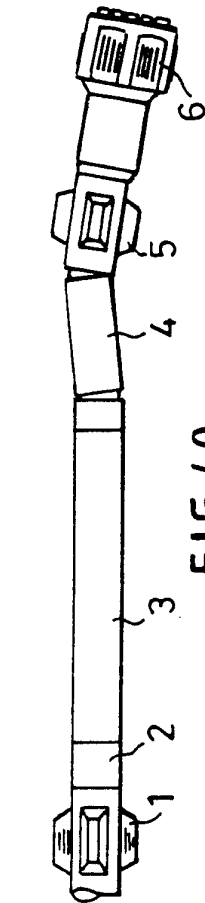

FIG. 41

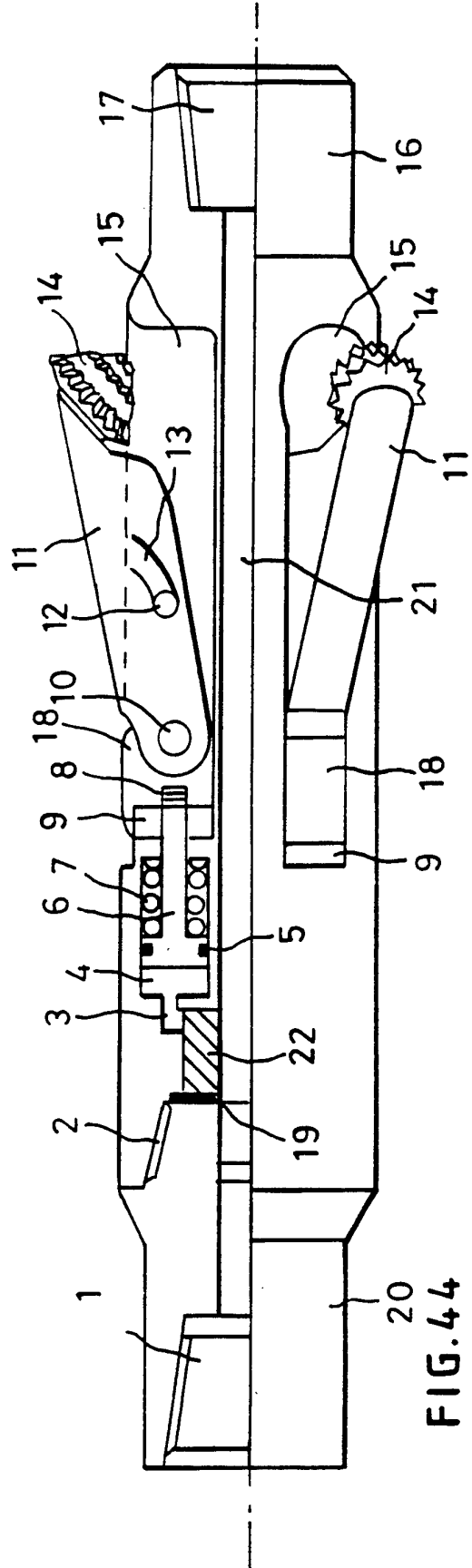
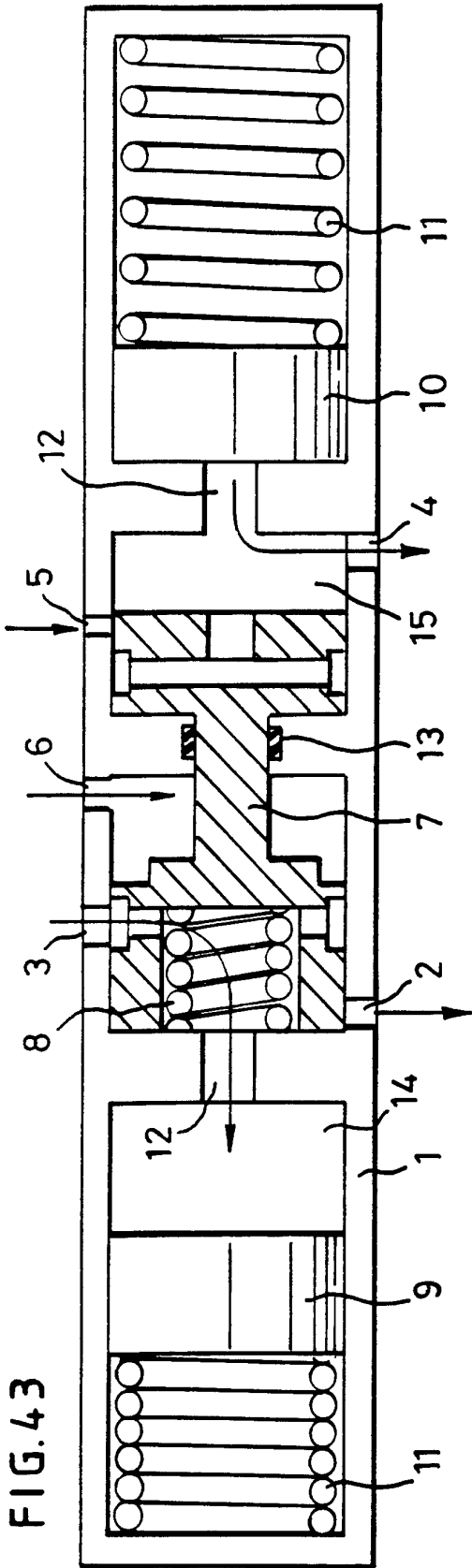
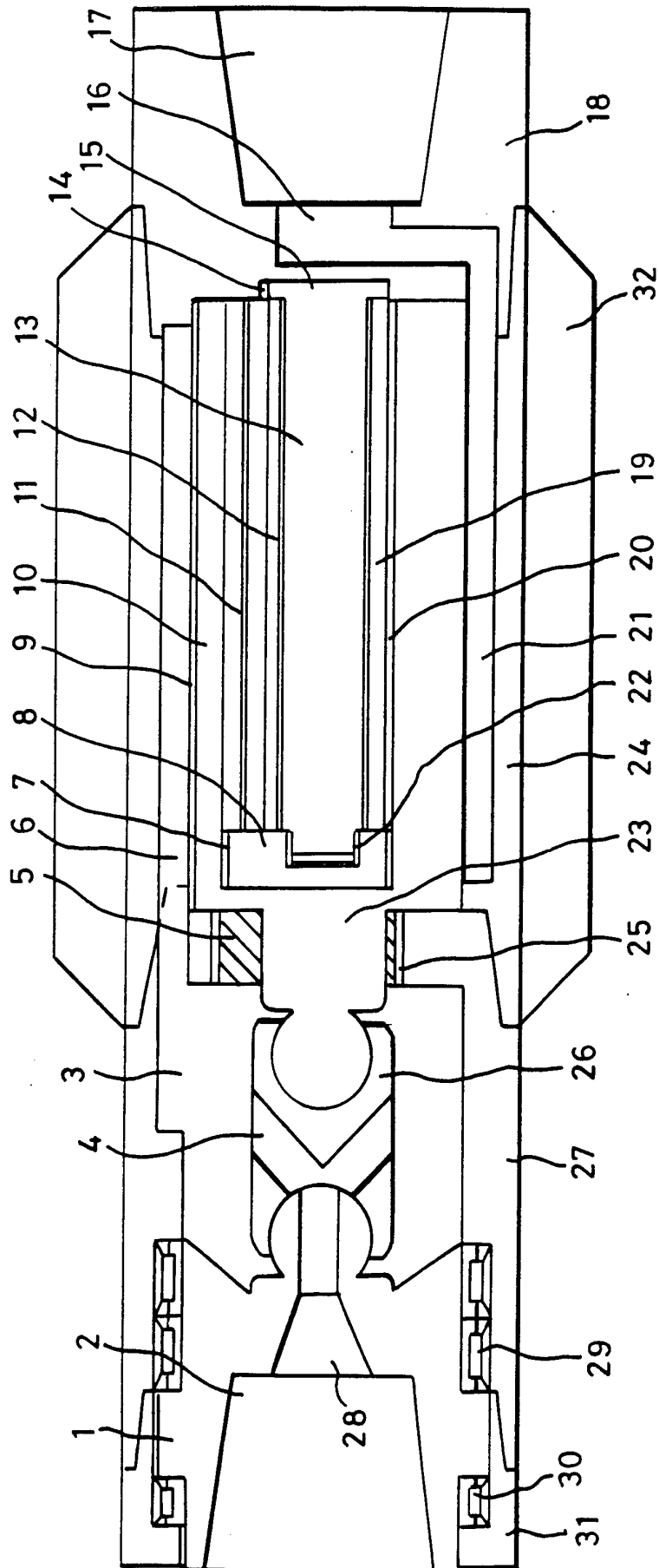

FIG.45



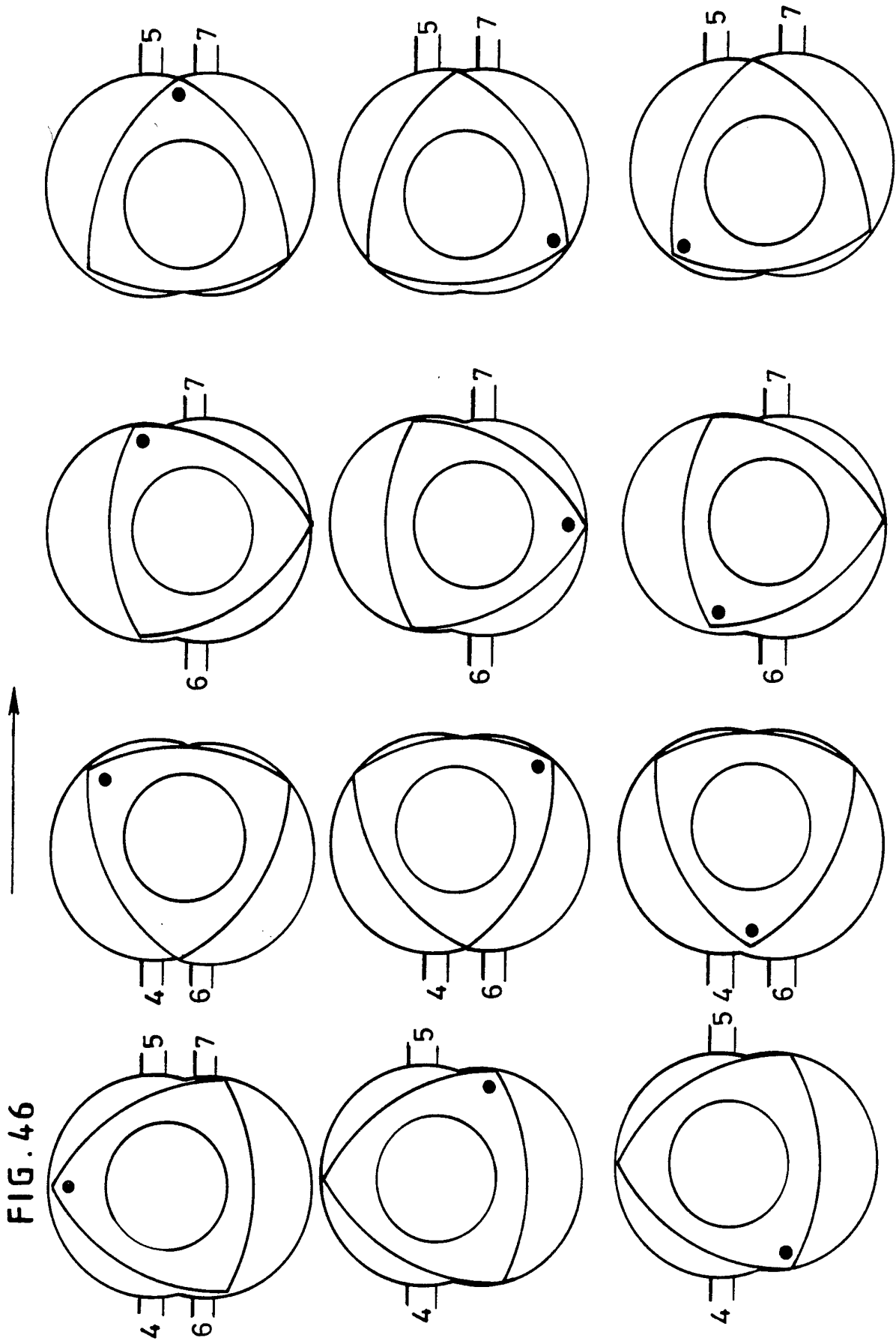

FIG. 46

