

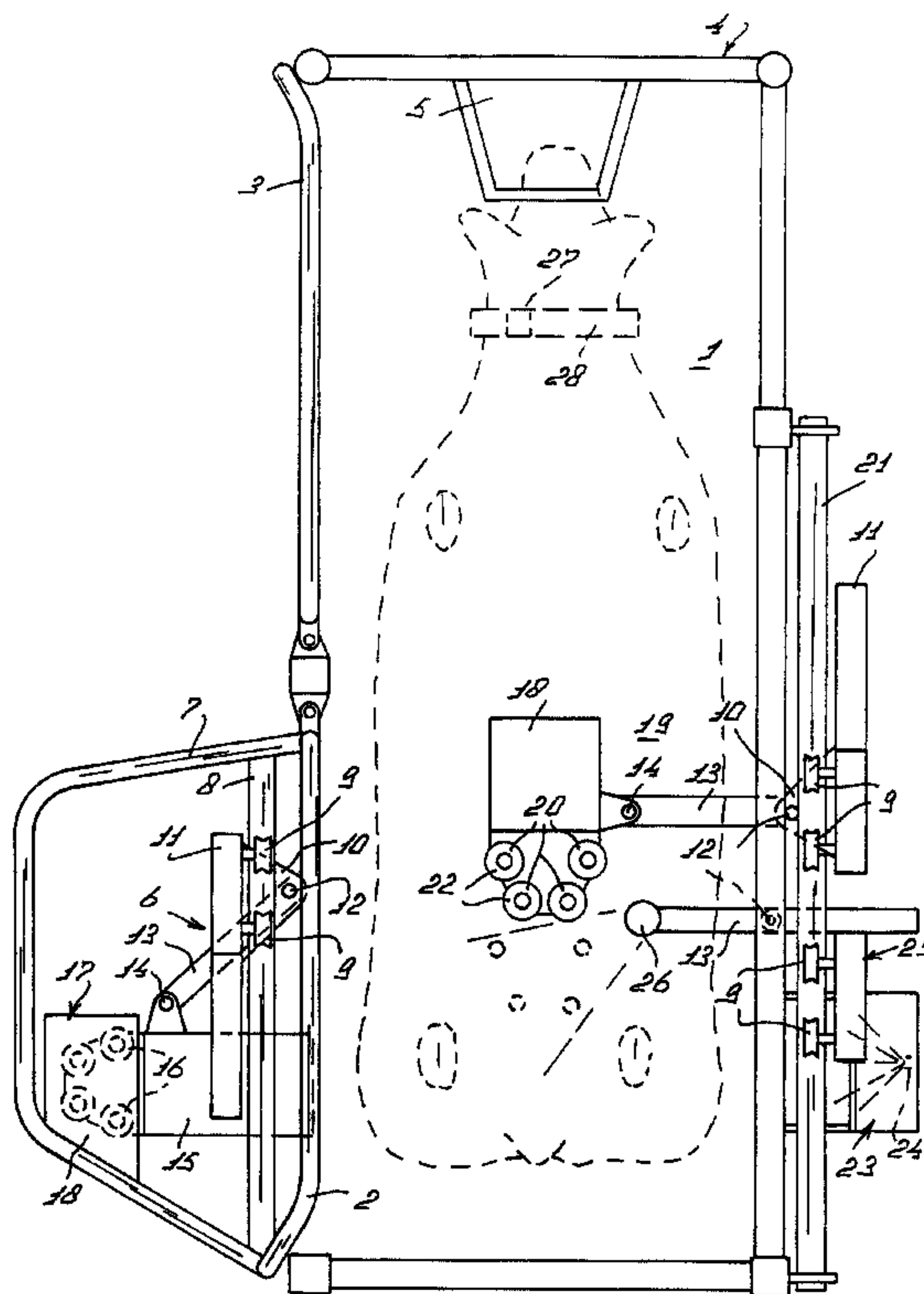

(86) Date de dépôt PCT/PCT Filing Date: 1998/07/09
 (87) Date publication PCT/PCT Publication Date: 1999/01/28
 (45) Date de délivrance/Issue Date: 2007/05/22
 (85) Entrée phase nationale/National Entry: 1999/03/16
 (86) N° demande PCT/PCT Application No.: NL 1998/000398
 (87) N° publication PCT/PCT Publication No.: 1999/003331
 (30) Priorité/Priority: 1997/07/17 (NL1006607)

(51) Cl.Int./Int.Cl. *A01J 5/017* (2006.01),
A01J 7/02 (2006.01), *A01J 7/04* (2006.01)
 (72) Inventeurs/Inventors:
VAN DER LELY, CORNELIS, CH;
VAN DER LELY, OLAF, CH
 (73) Propriétaire/Owner:
MAASLAND N.V., NL
 (74) Agent: FETHERSTONHAUGH & CO.

(54) Titre : STRUCTURE CONTENANT UNE MACHINE A TRAIRE AUTOMATIQUE
 (54) Title: A CONSTRUCTION INCLUDING AN IMPLEMENT FOR AUTOMATICALLY MILKING ANIMALS



(57) Abrégé/Abstract:

The invention relates to a construction including an implement for automatically milking animals, such as cows, which implement comprises teat cups (16) which are capable of being connected to the teats of an animal to be milked. The implement comprises separate cups (20) which are capable of being connected to the teats of an animal and by means of which these teats can be cleaned or disinfected and/or foremilked. The implement is further provided with switch means for switching the separate cups (20) from the cleaning position into a foremilking position and/or a stimulating position, in the latter position the animal being stimulated to give the milk faster and/or earlier.

PCT

WORLD INTELLECTUAL PROPERTY ORGANIZATION
International Bureau

INTERNATIONAL APPLICATION PUBLISHED UNDER THE PATENT COOPERATION TREATY (PCT)

(51) International Patent Classification ⁶ : A01J 5/017, 7/04, 7/02	A1	(11) International Publication Number: WO 99/03331 (43) International Publication Date: 28 January 1999 (28.01.99)
---	----	--

(21) International Application Number: PCT/NL98/00398

(22) International Filing Date: 9 July 1998 (09.07.98)

(30) Priority Data:
1006607 17 July 1997 (17.07.97) NL

(71) Applicant (for all designated States except US): MAASLAND N.V. [NL/NL]; Weverskade 10, NL-3155 PD Maasland (NL).

(72) Inventors; and
(75) Inventors/Applicants (for US only): VAN DER LELY, Cornelis [NL/CH]; Brüschenrain 7, CH-6300 Zug (CH). VAN DER LELY, Olaf [NL/CH]; Weinbergstrasse 11, CH-6300 Zug (CH).

(74) Agent: MULDER, Herman; 10 Weverskade, NL-3155 PD Maasland (NL).

(81) Designated States: AU, CA, JP, NZ, US, European patent (AT, BE, CH, CY, DE, DK, ES, FI, FR, GB, GR, IE, IT, LU, MC, NL, PT, SE).

Published

With international search report.
In English translation (filed in Dutch).

(54) Title: A CONSTRUCTION INCLUDING AN IMPLEMENT FOR AUTOMATICALLY MILKING ANIMALS

(57) Abstract

The invention relates to a construction including an implement for automatically milking animals, such as cows, which implement comprises teat cups (16) which are capable of being connected to the teats of an animal to be milked. The implement comprises separate cups (20) which are capable of being connected to the teats of an animal and by means of which these teats can be cleaned or disinfected and/or foremilked. The implement is further provided with switch means for switching the separate cups (20) from the cleaning position into a foremilking position and/or a stimulating position, in the latter position the animal being stimulated to give the milk faster and/or earlier.

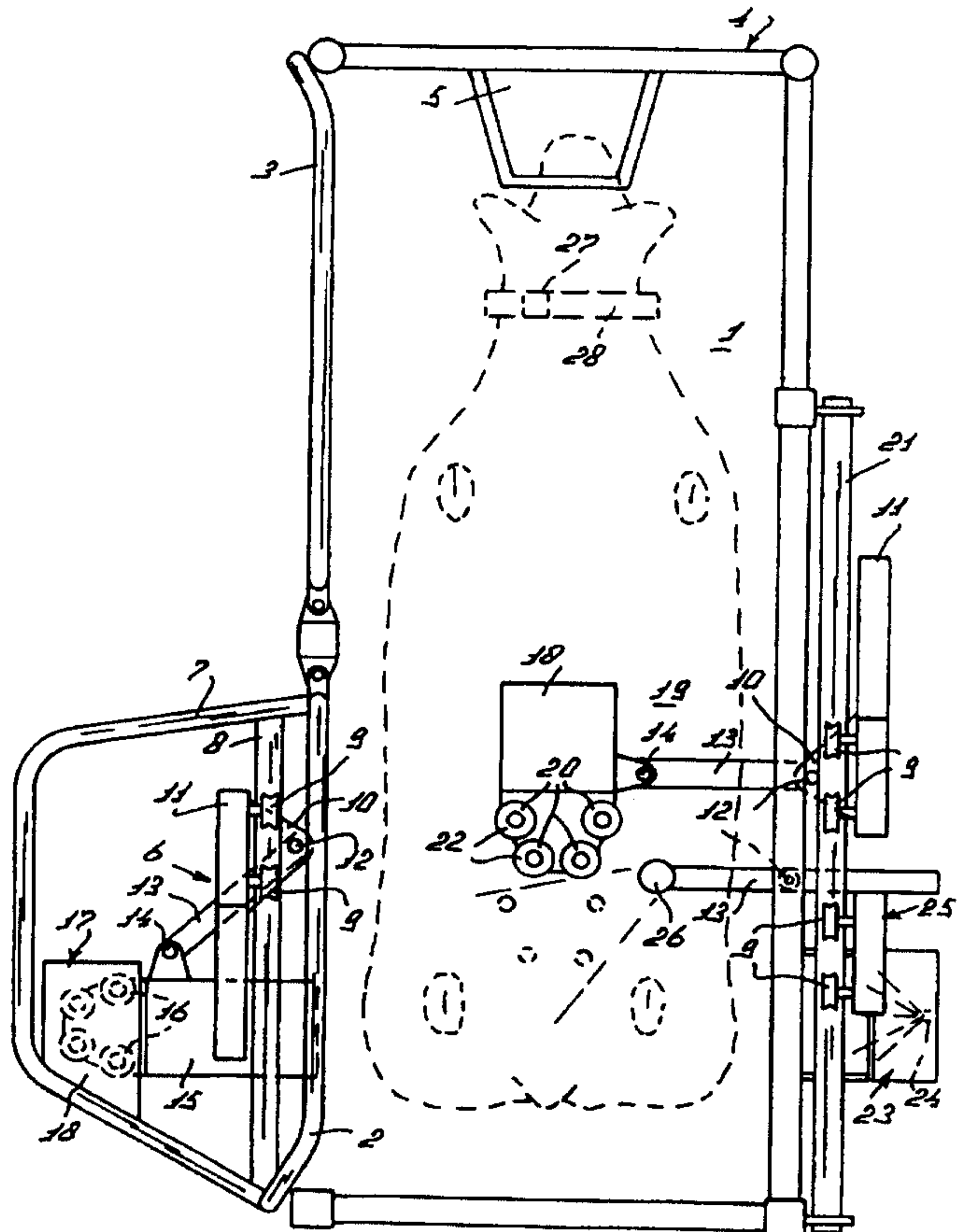

A CONSTRUCTION INCLUDING AN IMPLEMENT FOR AUTOMATICALLY
MILKING ANIMALS

5 The invention relates to a construction including
an implement for automatically milking animals, such as cows,
which implement comprises teat cups which are capable of
being connected to the teats of an animal to be milked.

Such an implement is known.

10 With such a construction it is important to work
very hygienically so that a high milk quality is obtained. In
particular the teats of the animal to be milked should
preferably be cleaned before milking. With a known construc-
tion this takes place by means of the teat cups themselves.
The disadvantage thereof is that cleaning fluid and/or
contamination may remain behind in the teat cup and be mixed
15 with the milk during milking. It will be obvious that this is
undesirable.

Therefore, the invention aims at obviating the
above-mentioned drawback or at least minimizing same.

20 In accordance with the invention, this is achieved
in that the implement comprises separate cups which are
capable of being connected to the teats of an animal and by
means of which these teats can be cleaned and/or disinfected
and/or foremilked. In this manner cleaning fluid and/or other
contaminations are prevented from being mixed with the milk
25 to be yielded thereafter.

30 According to a further inventive feature, the
implement is provided with switch means for the purpose of
switching the separate cups from the cleaning position into a
foremilking position and/or a stimulating position, in the
latter position the animal being stimulated to give the milk

faster and/or earlier. In order to facilitate the connection of separate cups, according to an inventive feature, the separate cups have a larger diameter than the teat cups. The separate cups preferably have a diameter being approximately one and a half times as large as the diameter of the teat cups. For the purpose of realizing a proper connection of the separate cups to the teats, according to a further inventive feature, the separate cups are provided near their upper sides with an enlarged contact face with which they are situated against the udder of an animal.

In order to prevent the cleaning and/or disinfecting fluid of the separate cups from being mixed with milk, according to an aspect of the invention, the separate cups comprise a separate supply and/or discharge line for supplying and/or discharging cleaning fluid or disinfecting fluid or foremilk or hot water. For the purpose of adjusting the intensity of the cleaning, according to an inventive feature, the implement comprises pressure adjusting means with the aid of which the pressure of the fluid and/or the air in the supply line can be adjusted.

For the purpose of a further automation of the implement, according to an inventive feature, the implement comprises a robot for the teat cups and a robot for the separate cups, with the aid of which robots the teat cups and the separate cups respectively can be connected to the teats of an animal. For determining the position of the teats, according to an inventive feature, the implement comprises a further robot with a detector disposed thereon. According to an inventive feature, the detector comprises a laser and/or an ultrasonic sensor and/or a camera.

In accordance with another inventive feature, the implement comprises a first cleaning device for cleaning the teat cups, as well as a second cleaning device for cleaning the separate cups. According to a further inventive feature, the first and the second cleaning device respectively comprise a space in which the teat cups and the separate cups respectively are cleaned with fluid and/or air. In this manner there is worked very hygienically, which has a favourable influence on the milk quality. In order to prevent

cleaning fluid from splashing away, according to an inventive feature, the first and the second cleaning device comprise a space in which the teat cups and separate cups having an other function than the teat cups can be cleaned respectively. In a preferred embodiment of the invention, the first cleaning device is located at one longitudinal side of the milk box, while the second cleaning device is situated at the other longitudinal side. According to again another inventive feature, in both spaces of the cleaning devices there are disposed storage means for storing the teat cups and the separate cups after operation. This prevents the teat cups and the separate cups from being contaminated. According to an aspect of the invention, the teat cups and/or the separate cups are connected to transport cables with the aid of which they can be moved to the storage means. Therefore, the invention also relates to a construction including an implement for automatically milking animals, such as cows, which implement comprises teat cups which are capable of being connected to the teats of an animal to be milked, characterized in that the implement comprises separate cups for cleaning and disinfecting the teats and for foremilked, the teat cups and/or the separate cups being connected to transport cables with the aid of which, after operation, they can be conveyed to the storage means.

For the purpose of an efficient way of working, according to an inventive feature, the implement comprises switch means with the aid of which the first cleaning device can be activated for cleaning therewith the teat cups when the separate cups are operative, as well as switch means with the aid of which the second cleaning device can be activated for cleaning therewith the separate cups when the teat cups are operative. Therefore, the invention furthermore relates to a construction including an implement for automatically milking animals, such as cows, which implement comprises teat cups which are capable of being connected to the teats of an animal to be milked, characterized in that the implement comprises separate cups for cleaning and/or disinfecting the teats and/or for foremilked, as well as switch means with the aid of which the separate cups can be cleaned during

24268-378

4

operation of the teat cups and with the aid of which the teat cups can be cleaned during operation of the separate cups. According to an aspect of the invention, the switch means are activated each time after operation of both the
5 teat cups and the separate cups.

In accordance with an inventive feature, the implement comprises a computer and/or an animal identification system. According to a further inventive feature, in the computer and/or the animal identification
10 system there is recorded per animal or per group of animals whether the teats are stimulated by means of the teat cups or the separate cups and by means of which cups foremilking takes place.

In accordance with one broad aspect of the present
15 invention, there is provided a construction including an implement for automatically milking animals, which implement comprises teat cups which are capable of being connected to the teats of an animal to be milked, and which implement comprises separate cups having another function than teat
20 cups and which can be connected to the teats of an animal, wherein the implement comprises a second cleaning device for cleaning the separate cups.

In accordance with another aspect of the present invention, there is provided a method for automatically
25 milking animals, such as cows, the method comprising the steps of attaching teat cups to the teats of an animal for milking the animal, and attaching separate cups to the teats of an animal for performing another function, and cleaning the separate cups.

30 The invention will now be explained in further detail with reference to the accompanying drawing.

24268-378

4a

Figure 1 shows schematically a plan view of a milk box, a robot arm with teat cups and a robot arm with separate cups being disposed therein.

Figure 1 shows a plan view of a milk box 1 provided with an entrance door 2 and an exit door 3. Near the front side of the milk box 1, a feed trough 5 is fitted to the frame 4, in which feed trough 5 fodder, such as concentrate, can be fed to an animal present in the milk box 1.

10 To the entrance door 2 there is fitted a milking robot 6. The milking robot 6 is surrounded by a U-shaped protective bracket 7 which is disposed on the entrance door 2. Between the two legs of the U-shaped protective bracket 7 there is disposed a longitudinal guide means 8
15 extending in the longitudinal direction of the milk box 1 and along which the milking robot 6 can be moved via a pair of rollers 9 by a (non-shown) motor, preferably a stepper motor. The milking robot 6 comprises a first robot arm 10 which is fastened to a support beam 11 to which the rollers
20 9 are attached. The first robot arm 10 is hingeably connected to a second robot arm 13 via a vertical axis 12. The second robot arm 13 itself is hingeably connected about a vertical axis 14 to a third robot arm 15 carrying four teat cups 16 at one of its ends. In the position shown in
25 Figure 1 the teat cups 16 are inoperative. The first, second and third robot arms 10; 13;

15 can be rotated relative to each other by (non-shown) motors, such as stepper motors and/or pneumatic or hydraulic, possibly servo-controlled cylinders. The milking robot 6 can further be moved in height by a (non-shown) hingeable arm construction.

To the U-shaped protective bracket 7 there is further fitted a first cleaning device 17 for cleaning of the teat cups. The first cleaning device 17 comprises a box-shaped housing 18 in which the teat cups 16 can be cleaned by means of fluid and/or air.

Near the other longitudinal side of the milk box 1 there is arranged a robot 19 with separate cups 20 which are capable of being connected to the animal's teats which can thus be cleaned and/or disinfected and/or foremilked and/or stimulated to give milk. Like the previous milking robot 6, the robot 19 is movable via a longitudinal guide means 21 which is fastened to the frame 4 of the milk box 1 and extends in the longitudinal direction of the milk box 1. Apart from the cups 20, the robot 19 is designed in the same manner and therefore indicated in Figure 1 by the same reference numerals. The separate cups 20 have a larger diameter, preferably one and a half times as large as the teat cups 16. Each of the separate cups 20 is further provided with a relatively large contact face 22 with which the cup, when it is connected to a teat, is situated against the udder of the animal. The large contact face 22 ensures that the interior space of the separate cup 20 is properly shut off from the environmental atmosphere.

Near the same longitudinal side as where the robot 19 is arranged, near the rear side of the milk box 1 there is disposed a second cleaning device 23 for cleaning and/or disinfecting the separate cups 20. Like the first cleaning device 17, the second cleaning device 23 is provided with a box-shaped housing 18 with a cleaning member 24 disposed therein by means of which cleaning member 24 water, air or disinfecting fluid can be spouted both into and against the separate cups 20.

To the longitudinal guide means 21 there is fitted a further robot 25 in a similar manner as the robot 19.

Therefore, corresponding parts are indicated by the same reference numerals. At the end of the arm 13 of the further robot 25 there is fitted a detector 26 with the aid of which the position of the teats of an animal can be determined. The
5 detector 26 comprises a (non-shown) laser.

For the purpose of identifying the animal present in the milk box 1, the implement comprises a (non-shown) animal identification system and a computer which are capable of cooperating with a data carrier 27 which is disposed
10 around the neck of the animal via a collar 28.

The above described implement functions as follows:

The animal can enter the milk box 1 via the entrance door 2, whereafter the animal is identified by means of the (non-shown) animal identification system. If there has
15 been established that the animal is to be milked and/or to be foremilked and/or the animal's teats are to be cleaned, there is fed to the animal a dosaged quantity of concentrate in the feed trough 5 via a (non-shown) concentrate dosage system. Then, by means of the further robot 25, the position of the
20 teats of the animal is determined. Thereafter the robot 19 is activated and the separate cups 20 are connected to the teats of the animal. Depending on how the computer is preprogrammed the animal can subsequently be cleaned and/or disinfected and/or stimulated and/or foremilked by means of the separate
25 cups 20. Thereafter the separate cups 20 are moved to the second cleaning device 23 and (non-shown) switch means are operated by the computer, in such a manner that the separate cups 20 are cleaned and/or disinfected by means of the second
30 cleaning device 23. During cleaning of the separate cups 20 the milking robot 6 is activated and the teat cups 16 are connected to the teats of the animal to be milked, whereafter the animal is milked. When there has been established by the computer that the animal has been milked, the teat cups 16 are moved to the first cleaning device 17 with the aid of the
35 milking robot 6. Subsequently the switch means are activated again by the computer, in such a manner that the teat cups 16 are cleaned and/or disinfected. It is also possible to adjust the switch means in such a manner that both the teat cups 16 and the separate cups 20 are cleaned by air and/or blown dry.

WO 99/03331

PCT/NL98/00398

7

Cleaning and/or disinfecting or blowing dry or blowing clean of the teat cups 16 can go on, even when the entrance door 2 is opened for a next animal.

24268-378

8

CLAIMS:

1. A construction including an implement for automatically milking animals, which implement comprises teat cups which are capable of being connected to the teats
5 of an animal to be milked, and which implement comprises separate cups having another function than teat cups and which can be connected to the teats of an animal, wherein the implement comprises a second cleaning device for cleaning the separate cups.
- 10 2. The construction as claimed in claim 1, wherein by means of the separate cups the teats can be at least one of, cleaned, foremilked, disinfected and stimulated.
3. The construction as claimed in claim 1 or 2, wherein the implement is provided with a first cleaning
15 device for cleaning the teat cups.
4. The construction as claimed in claim 3, wherein the first cleaning device and the second cleaning device respectively comprise a space in which the teat cups and the separate cups respectively are cleaned with at least one of
20 fluid and air.
5. The construction as claimed in claim 4, wherein the first cleaning device is located at one longitudinal side of a milk box, while the second cleaning device is situated at the other longitudinal side.
- 25 6. The construction as claimed in claim 4 or 5, wherein both spaces there are disposed storage means for storing the teat cups and the separate cups after operation.
7. The construction as claimed in any one of claims 1 to 6, wherein the separate cups have a larger diameter than
30 the teat cups.

24268-378

9

8. The construction as claimed in claim 7, wherein the diameter of the separate cups is approximately one and a half times as large as the diameter of the teat cups.

9. The construction as claimed in any one of claims 1
5 to 8, wherein the separate cups are provided near their upper sides with an enlarged contact face with which the separate cups are situated against the udder of the animal when they are connected to the teats.

10. The construction as claimed in any one of claims 1
10 to 9, wherein the implement comprises a milking robot for the teat cups and a robot for the separate cups.

11. The construction as claimed in any one of claims 1
to 10, wherein the implement comprises a further robot with a detector disposed thereon for determining the position of
15 the teats.

12. The construction as claimed in claim 11, wherein the detector comprises at least one of a laser, an ultrasonic sensor and a camera.

13. A method for automatically milking animals, such
20 as cows, the method comprising the steps of attaching teat cups to the teats of an animal for milking the animal, and attaching separate cups to the teats of an animal for performing another function, and cleaning the separate cups.

14. The method as claimed in claim 13, further
25 including the step of cleaning the teat cups.

15. The method as claimed in claim 14, wherein the step of cleaning the separate cups takes place during the step of milking the animal with the teat cups.

24268-378

10

16. The method as claimed in claim 14 or 15, wherein the step of cleaning the teat cups takes place during performing of the other function with the separate cups.

17. The method as claimed in any one of claims 13 to 5 16, wherein the method subsequently comprises the steps of:

- determining the position of the teats of the animal;

- attaching the separate cups to the teats;

10 - at least one of cleaning, disinfecting, stimulating, and foremilking the teats;

- at least one of cleaning and disinfecting the separate cups;

15 - during the at least one of cleaning and disinfecting the separate cups, attaching the teat cups to the teats;

- at least one of cleaning and disinfecting the teat cups.

18. The method as claimed in any one of claims 13 to 17, wherein there is determined per animal or per group of 20 animals which operations are performed on the animal(s).

19. The construction as claimed in claim 3, wherein the first cleaning device is located at one longitudinal side of a milk box, while the second cleaning device is situated at the other longitudinal side.

24268-378

11

20. The method as claimed in claim 13, wherein the step of cleaning the separate cups takes place during the step of milking the animal with the teat cups.

FETHERSTONHAUGH & CO.

OTTAWA, CANADA

PATENT AGENTS

