

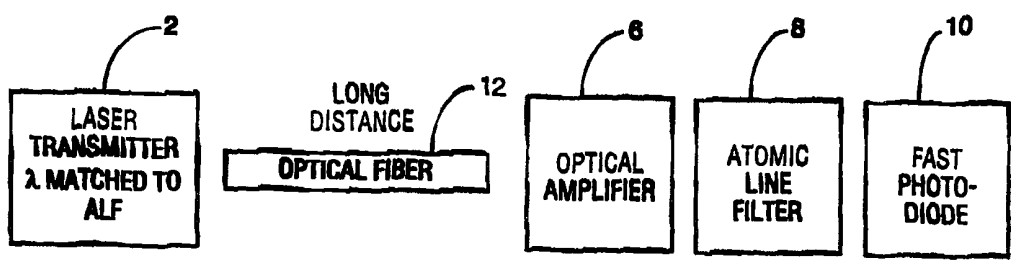

INTERNATIONAL APPLICATION PUBLISHED UNDER THE PATENT COOPERATION TREATY (PCT)

<p>(51) International Patent Classification ⁶ : H04B 10/06</p>	<p>A1</p>	<p>(11) International Publication Number: WO 99/12286 (43) International Publication Date: 11 March 1999 (11.03.99)</p>
<p>(21) International Application Number: PCT/US98/18192 (22) International Filing Date: 1 September 1998 (01.09.98) (30) Priority Data: 08/921,812 2 September 1997 (02.09.97) US (71) Applicant: TREX COMMUNICATIONS CORPORATION [US/US]; 10455 Pacific Center Drive, San Diego, CA 92121 (US). (72) Inventors: SPIVEY, Brett; 131 Seeman Drive, Encinitas, CA 92024 (US). MENDERS, James; 943 Oliver Avenue, San Diego, CA 92109 (US). (74) Agent: LAND, John; Fish & Richardson P.C., Suite 1400, 4225 Executive Square, La Jolla, CA 92037 (US).</p>		<p>(81) Designated States: AL, AM, AT, AU, AZ, BA, BB, BG, BR, BY, CA, CH, CN, CU, CZ, DE, DK, EE, ES, FI, GB, GE, GH, GM, HR, HU, ID, IL, IS, JP, KE, KG, KP, KR, KZ, LC, LK, LR, LS, LT, LU, LV, MD, MG, MK, MN, MW, MX, NO, NZ, PL, PT, RO, RU, SD, SE, SG, SI, SK, SL, TJ, TM, TR, TT, UA, UG, UZ, VN, YU, ZW, ARIPO patent (GH, GM, KE, LS, MW, SD, SZ, UG, ZW), Eurasian patent (AM, AZ, BY, KG, KZ, MD, RU, TJ, TM), European patent (AT, BE, CH, CY, DE, DK, ES, FI, FR, GB, GR, IE, IT, LU, MC, NL, PT, SE), OAPI patent (BF, BJ, CF, CG, CI, CM, GA, GN, GW, ML, MR, NE, SN, TD, TG).</p> <p>Published <i>With international search report. Before the expiration of the time limit for amending the claims and to be republished in the event of the receipt of amendments.</i></p>

(54) Title: OPTICAL COMMUNICATION SYSTEM



(57) Abstract

A high speed optical receiver (fig. 1) for receiving a substantially diminished optical signal. An optical amplifier (6) amplifies the diminished optical signal at least at several db and an ultra narrow-band filter filters (8) the noise generated in the optical amplifier (6) to produce a filtered amplified optical signal which is detected by a fast response photo detector (10). In a preferred embodiment the optical amplifier is a semiconductor laser amplifier. In this embodiment a Faraday filter provides the ultra narrow-band filtering, virtually eliminating the noise produced by the amplifier. Transmitters are described for transmitting information at a wavelength tuned to the ultra narrow-band filters.

FOR THE PURPOSES OF INFORMATION ONLY

Codes used to identify States party to the PCT on the front pages of pamphlets publishing international applications under the PCT.

AL	Albania	ES	Spain	LS	Lesotho	SI	Slovenia
AM	Armenia	FI	Finland	LT	Lithuania	SK	Slovakia
AT	Austria	FR	France	LU	Luxembourg	SN	Senegal
AU	Australia	GA	Gabon	LV	Latvia	SZ	Swaziland
AZ	Azerbaijan	GB	United Kingdom	MC	Monaco	TD	Chad
BA	Bosnia and Herzegovina	GE	Georgia	MD	Republic of Moldova	TG	Togo
BB	Barbados	GH	Ghana	MG	Madagascar	TJ	Tajikistan
BE	Belgium	GN	Guinea	MK	The former Yugoslav Republic of Macedonia	TM	Turkmenistan
BF	Burkina Faso	GR	Greece	ML	Mali	TR	Turkey
BG	Bulgaria	HU	Hungary	MN	Mongolia	TT	Trinidad and Tobago
BJ	Benin	IE	Ireland	MR	Mauritania	UA	Ukraine
BR	Brazil	IL	Israel	MW	Malawi	UG	Uganda
BY	Belarus	IS	Iceland	MX	Mexico	US	United States of America
CA	Canada	IT	Italy	NE	Niger	UZ	Uzbekistan
CF	Central African Republic	JP	Japan	NL	Netherlands	VN	Viet Nam
CG	Congo	KE	Kenya	NO	Norway	YU	Yugoslavia
CH	Switzerland	KG	Kyrgyzstan	NZ	New Zealand	ZW	Zimbabwe
CI	Côte d'Ivoire	KP	Democratic People's Republic of Korea	PL	Poland		
CM	Cameroon	KR	Republic of Korea	PT	Portugal		
CN	China	KZ	Kazakstan	RO	Romania		
CU	Cuba	LC	Saint Lucia	RU	Russian Federation		
CZ	Czech Republic	LI	Liechtenstein	SD	Sudan		
DE	Germany	LK	Sri Lanka	SE	Sweden		
DK	Denmark	LR	Liberia	SG	Singapore		
EE	Estonia						

- 1 -

OPTICAL COMMUNICATION SYSTEM

BACKGROUND OF THE INVENTION

Optical communications system receivers need high sensitivity and fast response. One approach to selecting an optical receiver for a communications system is to first identify
5 receivers of sufficient sensitivity, and then to pick the receiver with the fastest response among them. Such a procedure has led the free space communications industry to select silicon avalanche photodiodes (APDs) for long distance, free space laser communications system operating at a wavelength of about 0.8 μm . However, the response time of APDs is generally limits them to signals at a GHz. The speed of the APDs is limited by a time
10 constant associated with the electron multiplication process. Much faster speeds are achievable using p-i-n photodiodes. However, the p-i-n photo diode sensitivity is not sufficient for many applications. It is known that the sensitivity of a p-i-n photo diode-based photo receiver can be increased by adding an optical preamplifier ahead of the photo diode to first amplify the optical signal prior to photo detection. The use of optical
15 preamplifiers for laser receivers in fiber optics communications systems is known. The preamplifiers themselves typically consist of semiconductor lasers with reduced facet reflectivities, operated just below the lasing threshold. These semiconductor laser amplifiers do a good job of amplifying the signal, producing amplifications in of up to 25 to 30 db. However, the amplifiers are very noisy. Interference filters have been
20 proposed to cut down on the amplifier noise with only limited success.

It is known that atomic line filters can be used to obtain ultra narrow band optical filtering. Faraday filters are also know and have been used to provide ultra narrow-band optical filtering. See Menders et al, "Ultra narrow line filtering using a Cs Faraday filter at 852 nm" (OPTICS LETTERS, Vol. 16, No. 11, June 1, 1991).

- 2 -

What is needed is an optical communication system having transmitting and receiving components in which a signal beam which can be allowed to diminish to extremely low levels and still be detected by the optical receiving components in the system.

SUMMARY OF THE INVENTION

5 The present invention provides a high speed optical receiver for receiving a substantially diminished optical signal. An optical amplifier amplifies the diminished optical signal at least several db and an ultra narrow-band filter filters the noise generated in the optical amplifier to produce a filtered amplified optical signal which is detected by a fast response photo detector. In a preferred embodiment the optical amplifier is a
10 semiconductor laser amplifier. In this embodiment a Faraday filter provides the ultra narrow-band filtering, virtually eliminating the noise produced by the amplifier. Transmitters are described for transmitting information at a wavelength tuned to the ultra narrow-band filters.

BRIEF DESCRIPTION OF THE DRAWINGS

15 FIG. 1 is a block diagram of a first preferred embodiment of the present invention.

FIG. 2 is a block diagram of a second preferred embodiment of the present invention.

FIG. 3 is a drawing showing the general shape of signals at various locations in the above
20 second preferred embodiment.

FIG. 4 is a block diagram showing the components laser transmitter referred to in FIG.

1.

- 3 -

FIG. 5 is a part cross section drawing part block diagram showing the receiver module of the above preferred embodiment.

5 FIGS. 6A and 6B are drawings describing an alternative method of controlling transmission wavelengths.

FIG. 7 is a drawing explaining the principal of Faraday and Voigt filters.

10 FIGS. 8A, 8B and 8C show transmission specter of Voigt and Faraday filters compared to the absorption's spectrum of cesium.

DETAILED DESCRIPTION OF PREFERRED EMBODIMENTS

Atomic Line Filter vs. Conventional Filter

15 Conventional optical filters are relatively wide band filters as compared to atomic line filters; however, they can be simple, cheap and generally present no operational problems. A comparison of some of the principal features of these two types of filters is made in the following table:

	Atomic Line Filters	Conventional Filters
20 Bandwidth	0.01 nm	3.5 nm
Field of View	Wide up to 60 Degrees	Narrow, a Few Degrees
Insertion Loss	60%	30%
Size of Filter	Several cm Thick	5 mm Thick Plate
Power	5 W	Unpowered
Companion Laser	Precision, Narrow band Frequency Locked Laser Diode	High Peak Power Pulsed Laser
25 General Description	Costly, High Performance, Wide Field of View	Relatively Inexpensive, Moderate Performance, Moderate Field of View

- 4 -

Preferred Embodiments

Preferred embodiments of the present invention can be described by reference to the drawings.

FIG. 1 is a block diagram of a first preferred embodiment of the present invention. Laser transmitter 2 transmits a free space laser beam which is matched in wavelength to the very narrow pass band of atomic line filter 8. The beam is substantially diminished in power when it reaches the receiver consisting of a background optical filter 4, an optical amplifier 6, the atomic line filter 8 and a fast photo diode 10. FIG. 2 is a second preferred embodiment. In this embodiment the beam travels in optical fiber 12 and no background optical filter is provided. FIG. 3 gives qualitative representations: (a) of the signal 14 as it enters the optical fiber 12 of FIG. 2, (b) of the diminished signal 16 at the receiver end of the optical fiber, (c) of the amplified signal 18 after it has been amplified by optical amplifier 6, and (d) of the filtered amplified signal 20 after it has been filtered by atomic line filter 8. The effect of the optical amplifier is to greatly amplify the signal, but it also produces a large amount of interfering broadband noise.

Transmitter

A preferred transmitter is shown in FIG. 4. As stated above, the transmitter must transmit a signal beam having a spectrum matching the atomic line filter passband. A distributed Bragg reflector semiconductor laser designed to operate at a wavelength near 852 is a good match. Such lasers are commercially available. One preferred laser is a 150 mWatt diode laser 40 Model No. SSL-5722-H1 supplied by SDL. This laser operates nominally at 852 nm wavelength. In this preferred embodiment, we lock the laser 40 at one of the precise wavelengths at or very near 852.11 nm, which corresponds to the $6s_{1/2} 6p_{3/2}$ transition in cesium. One way to do this, is to configure the laser system

- 5 -

into a wavelength controlled unit as shown in FIG. 4. This control is achieved using temperature control and current control of the laser and an ALF. A feedback circuit 63 is provided to control the diode current and maintain the output at the selected precise wavelength.

5 The temperature of the diode is regulated by thermoelectric heat pumps 41. The heat pumps are driven by a Wavelength Electronics FPT 2000 thermoelectric cooler controller 66. The temperature of the laser diode is maintained to within $\pm 0.05^{\circ}\text{C}$ of the required temperature for optimum wavelength stability. The laser diode is driven by a low noise, voltage controlled current source 64. The current source used to drive the cw laser diode
10 is Wavelength Electronics FPL 250. The laser diode output is collimated with a Rodenstock 1403.108 lens 42. Direct modulation of the laser at multi-Gbaud rates can be accomplished using an optical waveguide modulator 17 such as the United Technologies Phonic Mach-Zehnder modulator. These modulators preserve polarization and are supplied with fiber pigtails 19 at the input and output. Light is coupled into the
15 fiber using a microscopic objective 21. In this example the transmitted information is provided from computer 24 through data transceiver 18.

The microcontroller 68 is used to implement a digital frequency control loop. To set the laser frequency, the microcontroller will ramp the laser diode drive current up and down thereby ramping the laser frequency. The counters output is connected to a digital to
20 analog converter whose output drives the input of the voltage controlled current source. Output monitor photo diode 62 samples a small portion of the beam from diode 40 which is directed through atomic line filter 44. The signal from diode 62 is digitized and sent to the micro controller 68. The micro controller will drive the laser diode current up or down searching for the peak output as sensed by the output monitor photo diode. Once
25 the maximum output is detected the micro controller will then control the output drive current to maintain maximum light output from the laser assembly. The output of the laser is sampled every ten seconds.

- 6 -

Receiver Unit

The principal element of a preferred receiver unit are shown in block and cross section form in FIG. 5.

Background Optical Filter

- 5 Signal beam 1 enters background optical filter unit 4 which could any good optical filter. In this particular embodiment the filter is a Faraday atomic line filter (preferably the same model atomic line filter as is used in the transmitter to tune the laser diode transmitter. The signal beam enters through polarizer 70 which polarizes the light in a horizontal direction. An axial magnetic field of about 150 gauss created by magnet (not
- 10 shown) operating on cesium vapor heated to about 111°C by heater 76 in vapor cell 74 causes a rotation of only that portion of the light spectrum at wavelengths at sharp Cs absorption lines near 852 nm. That light which was so rotated passes through vertical polarizer 72 and is turned by prism 78. Other light is blocked by vertical polarizer 72 and 852 nm narrow band filter (Andover #850FS40-12.5) 82. (Please note that in some
- 15 applications [such as at night of if the field of view can be tightly controlled and when the optical signal is transmitted with an optical fiber] this background optical filter may not be needed.)

Optical Amplifier

- The detected signal is amplified, by optical amplifier 6. The amplifier is a high power
- 20 tapered stripe semiconductor amplifier that acts as a traveling wave amplifier. This amplifier with gain at the atomic line filter wavelength of 852 nm is provided by a modified off-the-shelf laser. The SDL Inc. model 8630 is an external cavity tunable laser which uses a tapered amplifier semiconductor chip as the active medium. It is easy to open the laser cavity with the insertion of a mirror to access the amplifier chip for a

- 7 -

single pass of the signal beam. The laser cavity itself is formed by one facet of the chip (the uncoated facet serves as the output coupler), and a grating placed several centimeters away. The signal beam is directed through the uncoated facet of the amplifier, and then turned out of the cavity by the mirror. We have observed overall single pass gains of
5 about 500 using this instrument.

Atomic Line Filter

The output of optical amplifier 6 enters atomic line filter 8. In this embodiment the atomic line filter is also a Faraday filter exactly like the one shown at 4. The filter consists of an atomic vapor in a cell located between a pair of crossed polarizers. A
10 magnetic field is applied to the cell which Zeeman splits the energy levels resulting in different absorption lines for left and right circularly polarized light. Near these lines the filter acts as a Faraday rotator providing rotary power only in the vicinity of an absorption line, which provides the 90 degree rotation necessary to pass the second
15 modulation sin the transmission spectrum. Away from the absorption line the filter provides an out of band rejection that is determined by the extinction ratio of the crossed polarizers.

Photo detector.

The output of atomic line filter 8 is detected by fast photo diode 10. For a nominal
20 GHz photo receiver, high speed off-the-shelf photodiodes are available from Newport B Corporation. The D-15 detector provides a bandwidth of 29 GHz.

Fiber-Optic Embodiment

When applying the present invention as a receiver or relayer in a fiber optic system, the diminished signal from the optical fiber is fed into optical amplifier 6 as shown in FIG.
25 5. Optical amplifier 6 and the components shown in FIG. 5 downstream of optical amplifier 6 are applicable to demonstrate the fiber-optic embodiment of the present invention.

- 8 -

15 GHz Transmission Rate

Both embodiments discussed above are designed for a Data transmission rate of about 15 GHz. We use a cesium Faraday filter designed to provide a 15 GHz pass band at 852 nm to remove the broad band amplified spontaneous emissions from the signal beam.

5

Faraday and Voigt Filters

Operational principles of our Faraday filter can be understood by reference to Figure 7. Crossed polarizers 90 and 91 serve to block out background light with a rejection ratio better than 10^{-5} . We use high transmission polarizers which have a transmission of higher than 95%. Because these polarizers only work over a limited wavelength region in the
10 infrared, a broad band interference filter is used in conjunction with the Faraday filter. Between the polarizers an atomic vapor (in this case cesium having a strong resonance near the wavelength of the beacon beam) in a magnetic field axially aligned with the path of the beam rotates the polarization of the beacon laser signal by 90° , while leaving other wavelengths unrotated, and thus blocked by the polarizers. The path of the transmitted
15 light is unaffected, so spatial information is maintained.

Polarization rotation is due to the separation in optical absorption frequencies for right and left circularly polarized light in the magnetic field due to the Zeeman effect. The index of refraction of the vapor near an absorption is different from 1, and the absorption separation causes the index to be different for right and left circular polarization at a
20 given frequency, and thus those polarizations travel through the vapor with a different phase velocity. The effect of this is to cause a frequency dependent rotation in the polarization of the incoming linearly polarized light which only occurs near the atomic absorption peak. Transmission through the filter is maximum where the polarization rotation is 90° , 270° , etc., provided that the frequency of the beam is far enough away
25 from the atomic resonance not to be absorbed. The Voigt filter is similar to the Faraday

- 9 -

filter. In the Voigt filter, a magnetic field is arranged so that the field lines are perpendicular to the beam direction. The vapor acts like a half wave plate rather than a Faraday rotation to achieve 90° polarization rotation. Transmission spectra in the range of 852 nm for cesium for the Faraday filter is shown in FIG. 8A and that for the Voigt filter is shown in FIG. 8B. (This spectrum is saturated with the laser power used in the locked beacon.)

Alternate Method of Wavelength Control

FIGS. 6A and 6B describe an alternate preferred method of controlling the transmission wavelength of the transmitter to match the known pass band of the receiving unit's Faraday atomic line filter. A sketch showing the passband is shown in FIG. 6B. In this setup an SDL 5712-H1 distributed Bragg reflector laser diode 154 is controlled with temperature controller 156 and current controller 158. Temperature controller 156 controls the temperature of the laser at a constant (within 0.050 degrees C) temperature in the range of about 25 degrees C. Feedback control is achieved with current controller 158. Microcontroller 160 keeps the current at a value, as indicated by the vertical dashed line in FIG. 6B to match a known transmission peak in the receive unit's atomic line filter. A portion of the laser beam is sampled and run through cesium absorption cell 162 and detected by photo diode 152. As shown in FIG. 6B a current matching the second ALF transmission peak is about 4/5 the distance between the cesium cell two absorption peaks of the cesium cell as detected during periodic (once per 10 seconds) calibration scans of photo diode 152. The scans take about 10 ms.

While the above description contains many specifics, the reader should not construe these as limitations on the scope of the invention, but merely as exemplification's of preferred embodiments thereof. Those skilled in the art will envision many other possible variations are within its scope. Accordingly the reader is requested to determine the scope of the invention by the appended claims and their legal equivalents, and not by the examples which have been given.

- 10 -

What is claimed is:

1. A high speed optical receiver for receiving a substantially diminished optical signal comprising:
 - an optical amplifier for amplifying said diminished optical signal at least several
5 db,
 - an ultra narrow-band filter for filtering noise generated in said optical amplifier to produce a filtered amplified optical signal and
 - a fast response photo detector for detecting said filtered amplified optical signal.
- 10 2. An optical receiver as in Claim 1 wherein said optical amplifier is a semiconductor optical amplifier.
3. An optical receiver as in Claim 2 wherein said semiconductor amplifier is a tapered stripe semiconductor amplifier.
4. An optical receiver as in Claim 1 wherein said ultra narrow-band filter is an atomic
15 line filter.
5. An optical receiver as in Claim 4 wherein said atomic line filter is a Faraday filter.
6. An optical receiver as in Claim 1 and further comprising a background filter positioned ahead of said optical amplifier for filtering background light.
7. An optical receiver as in Claim 5 and further comprising a background filter
20 positioned ahead of said optical amplifier for filtering background light wherein said background filter is a Faraday filter.

- 11 -

8. An optical receiver as in Claim 1 wherein said fast photo detector is a photodiode.
9. An optical receiver as in Claim 8 wherein said fast photo detector is a p-i-n photo diode.
10. A high speed optical receiver for receiving a substantially diminished optical signal
5 comprising:
a semiconductor optical amplifier for amplifying said diminished optical signal at least several db,
a Faraday filter for filtering noise generated in said optical amplifier to produce a filtered amplified optical signal and
10 a fast response photo diode for detecting said filtered amplified optical signal.
11. An optical communication system comprising:
A) a high speed optical receiver for receiving a substantially diminished optical signal comprising:
15 1) a semiconductor optical amplifier for amplifying said diminished optical signal at least several db,
2) a Faraday filter defining a passband for filtering noise generated in said optical amplifier to produce a filtered amplified optical signal and
3) a fast response photo diode for detecting said filtered amplified optical signal; and
20 B) a high speed optical transmitter for transmitting optical signals on a light beam to said receiver comprising:
1) a light source for producing light beam at a wavelength matched to the passband of said Faraday filter,
2) an optical modulator for modulating said light beam to impose said
25 optical signals on said beam.

- 12 -

12. An optical communication system as in Claim 11 wherein said system is a free space system and said receiver further comprises a background optical filter for filtering said
5 light beam.

13. An optical communication system as in Claim 12 wherein said background optical filter is a Faraday filter.

14. An optical communication system as in Claim 11 wherein said light source is a diode laser.

10

1/8

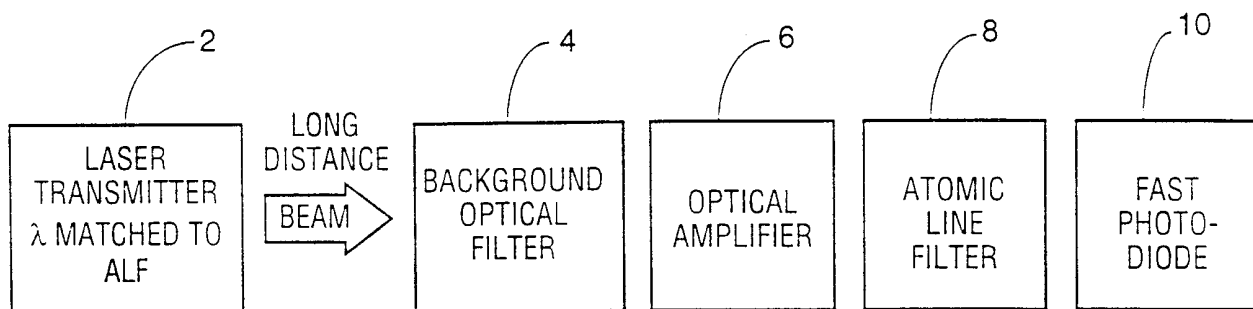

FIG. 1

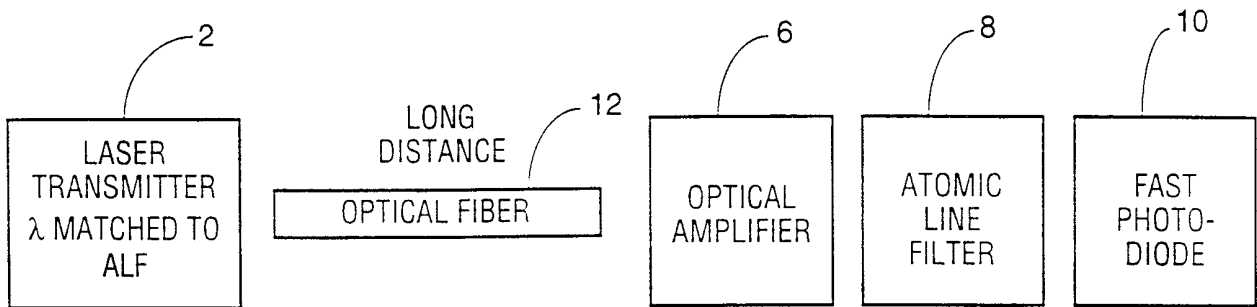

FIG. 2

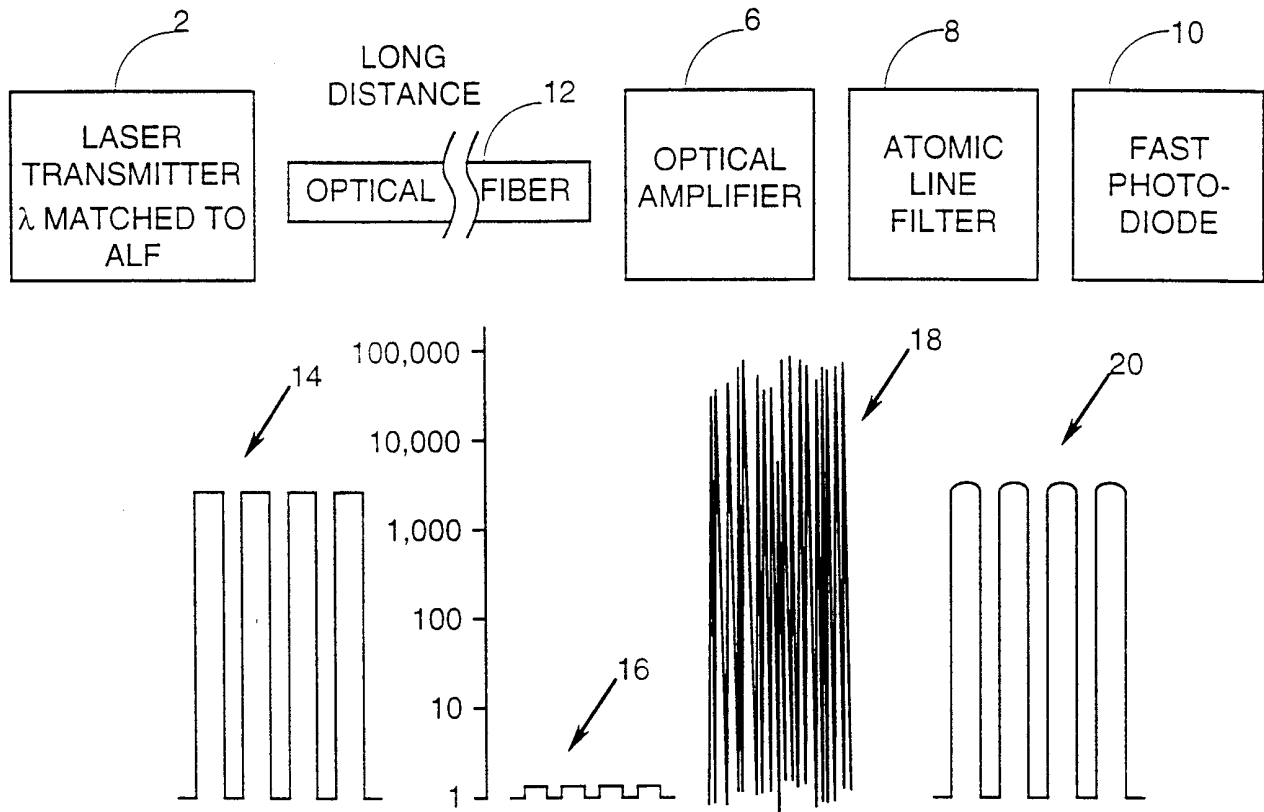

FIG. 3

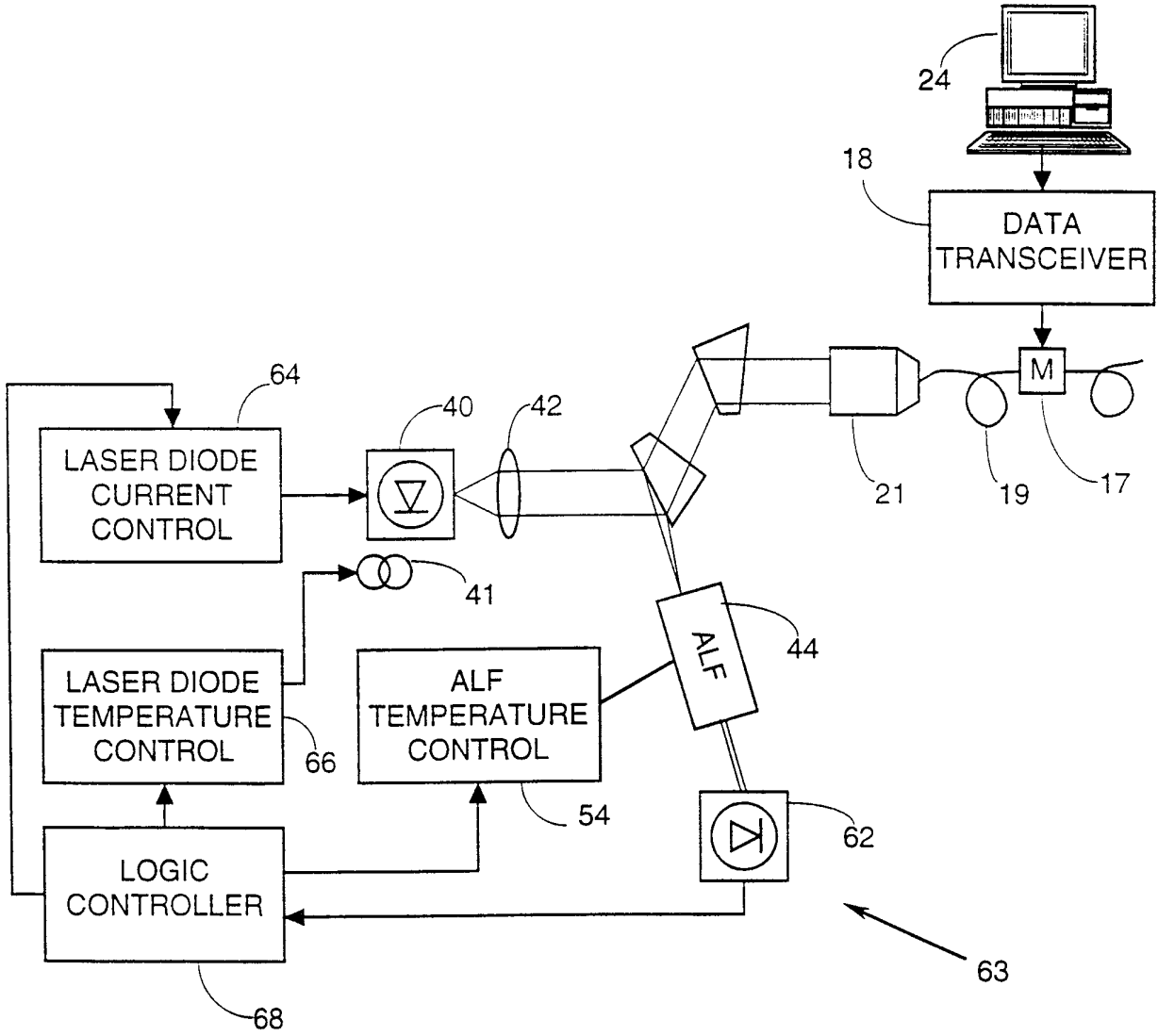

FIG. 4

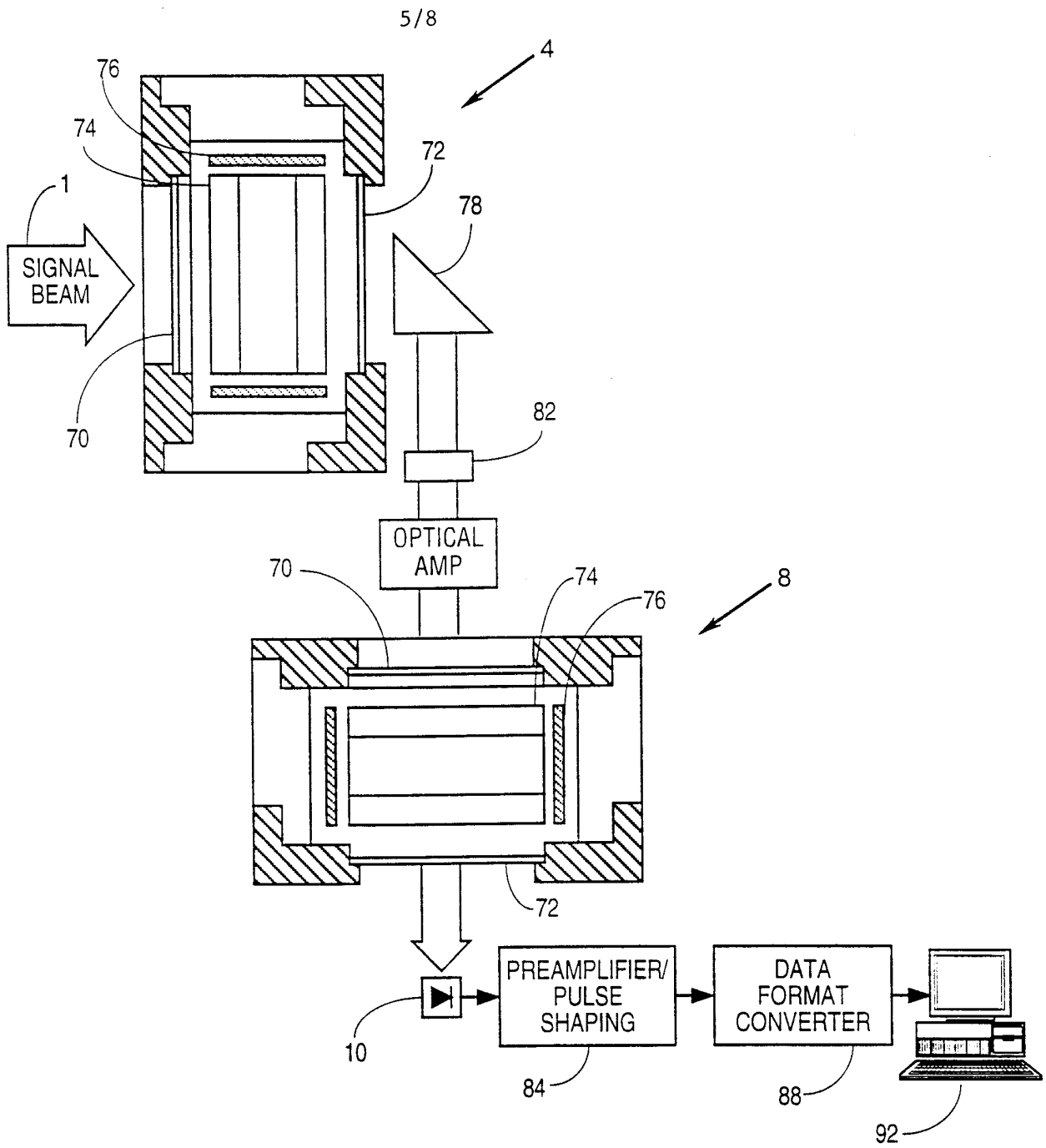

FIG. 5

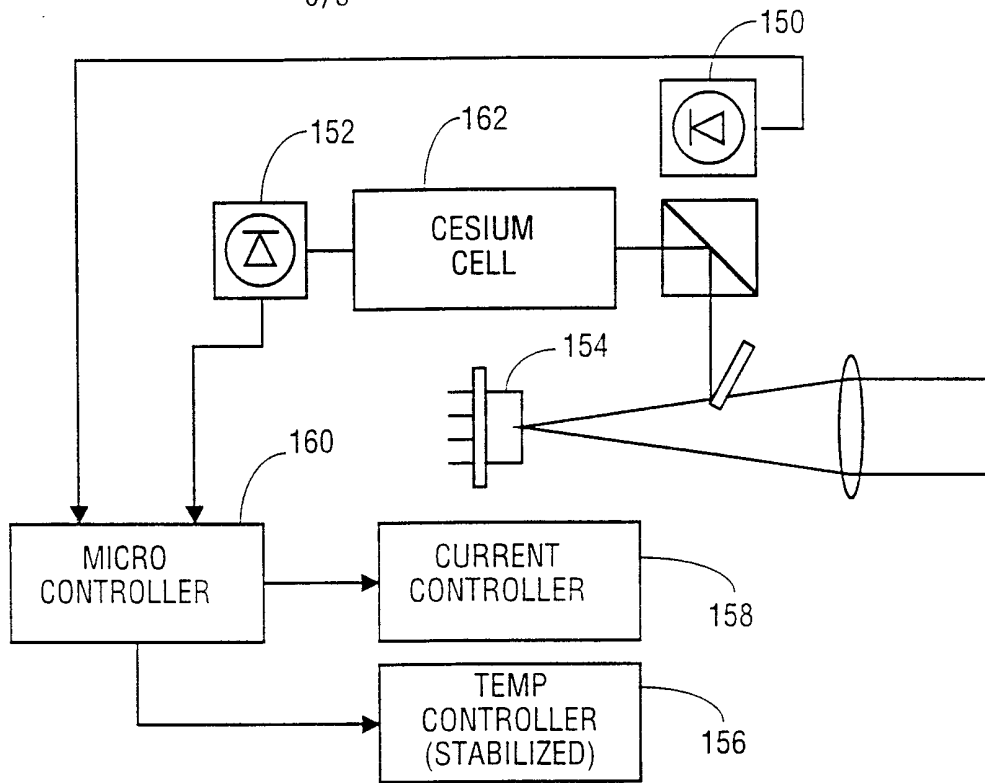

FIG. 6A

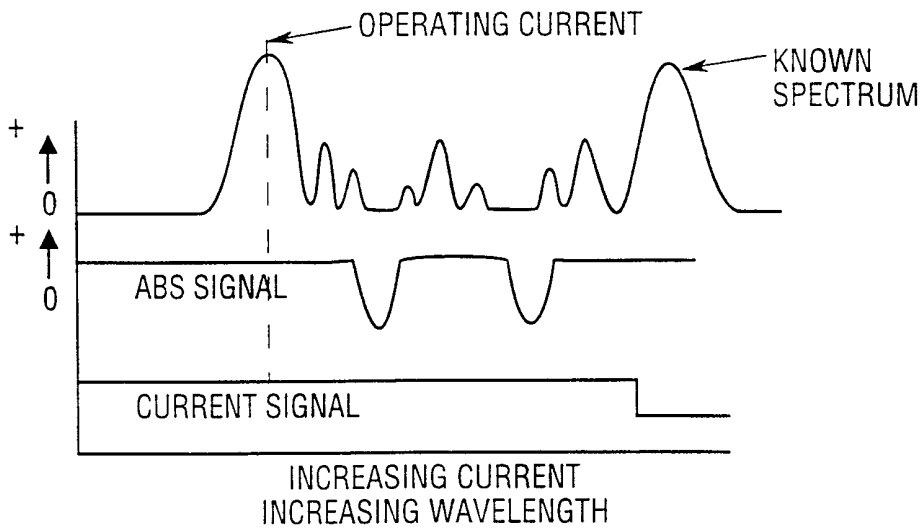

FIG. 6B

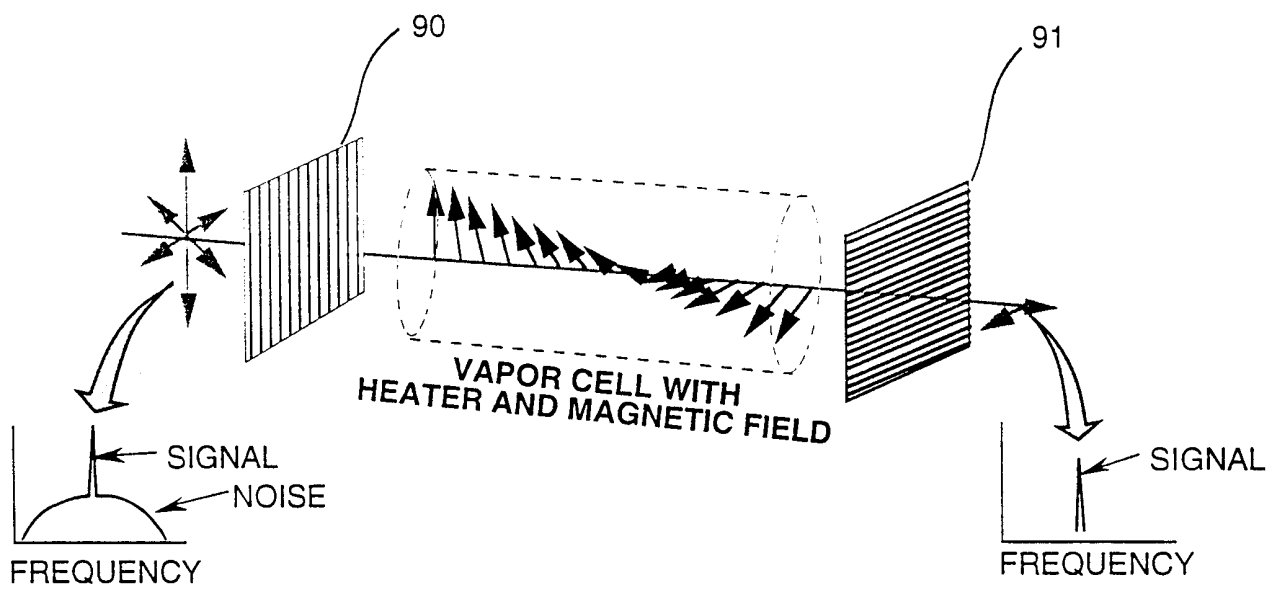
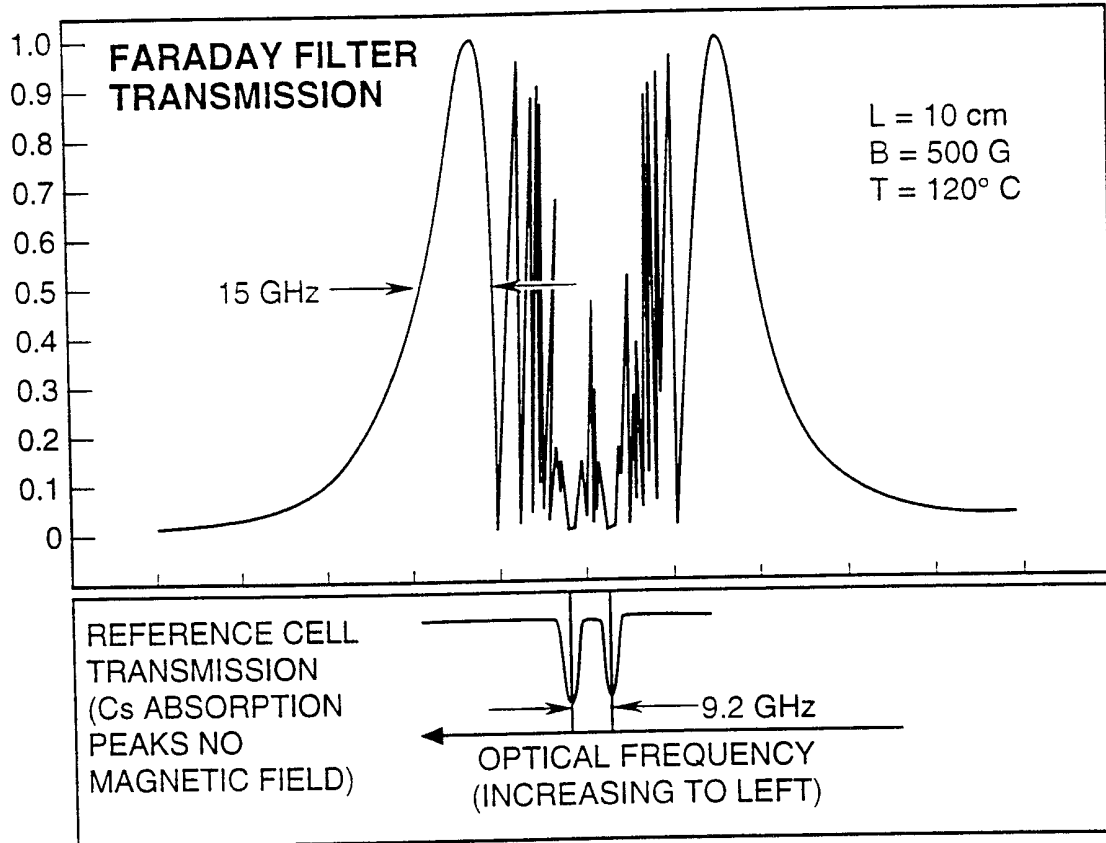

FIG. 7



INTERNATIONAL SEARCH REPORT

International application No.
PCT/US98/18192

A. CLASSIFICATION OF SUBJECT MATTER
 IPC(6) : H04B 10/06
 US CL : 359/ 189, 190, 191, 193, 194, 195
 According to International Patent Classification (IPC) or to both national classification and IPC

B. FIELDS SEARCHED
 Minimum documentation searched (classification system followed by classification symbols)
 U.S. : 359/ 189, 190, 191, 193, 194, 195

Documentation searched other than minimum documentation to the extent that such documents are included in the fields searched
 NONE

Electronic data base consulted during the international search (name of data base and, where practicable, search terms used)
 APS

C. DOCUMENTS CONSIDERED TO BE RELEVANT

Category*	Citation of document, with indication, where appropriate, of the relevant passages	Relevant to claim No.
X	US 5,537,634 A (FYE) 16 July 1996, col. 8, lines 39-56.	1-3, 6, 8-9
A	US 4,947,134 A (OLSSON) 07 August 1990, col. 3, lines 56-68.	1-3, 6, 8-9
A	US 5,390,202 A (YAN et al) 14 February 1995, col. 3, lines 1-20	1-3, 6, 8-9

Further documents are listed in the continuation of Box C. See patent family annex.

* Special categories of cited documents	*T* later document published after the international filing date or priority date and not in conflict with the application but cited to understand the principle or theory underlying the invention
A document defining the general state of the art which is not considered to be of particular relevance	*X* document of particular relevance, the claimed invention cannot be considered novel or cannot be considered to involve an inventive step when the document is taken alone
E earlier document published on or after the international filing date	*Y* document of particular relevance, the claimed invention cannot be considered to involve an inventive step when the document is combined with one or more other such documents, such combination being obvious to a person skilled in the art
L document which may throw doubts on priority claim(s) or which is cited to establish the publication date of another citation or other special reason (as specified)	*Z* document member of the same patent family
O document referring to an oral disclosure, use, exhibition or other means	
P document published prior to the international filing date but later than the priority date claimed	

Date of the actual completion of the international search 22 NOVEMBER 1998	Date of mailing of the international search report 29 JAN 1999
---	---

Name and mailing address of the ISA/US Commissioner of Patents and Trademarks Box PCT Washington, D.C. 20231 Facsimile No. (703) 305-3230	Authorized officer RAFAEL BACARES Telephone No. (703) 308-4928
---	--