



US 20040166251A1

(19) **United States**

(12) **Patent Application Publication**
Johnson

(10) **Pub. No.: US 2004/0166251 A1**

(43) **Pub. Date: Aug. 26, 2004**

(54) **STRUNG POPCORN SEEDS AND METHOD CONCERNING SAME**

Publication Classification

(76) **Inventor: Stephen D. Johnson, Sheridan, IL (US)**

(51) **Int. Cl.⁷ A47G 33/04**

(52) **U.S. Cl. 428/10**

Correspondence Address:
LEYDIG VOIT & MAYER, LTD
6815 WEAVER ROAD
ROCKFORD, IL 61114-8018 (US)

(57) **ABSTRACT**

The invention provides a method for creating a garland of popped seeds, a method for creating a string of unpopped seeds, and a method of manufacturing such a string. The method includes stringing a plurality of unpopped seeds and applying energy to the plurality of unpopped seeds. Another embodiment is directed to stringing a plurality of unpopped seeds on a string and organizing the seeds on the string to enable popping of the unpopped seeds by applying energy. The seeds can be popcorn seeds or any other seed that is capable of popping.

(21) **Appl. No.: 10/782,711**

(22) **Filed: Feb. 19, 2004**

Related U.S. Application Data

(60) **Provisional application No. 60/448,730, filed on Feb. 20, 2003.**

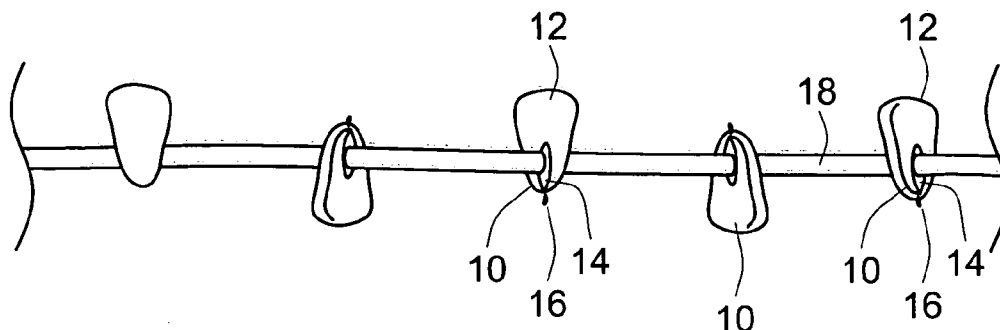

FIG. 1

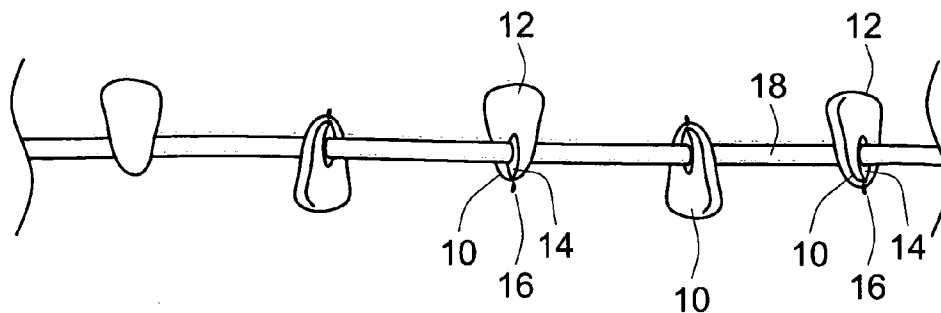

FIG. 2

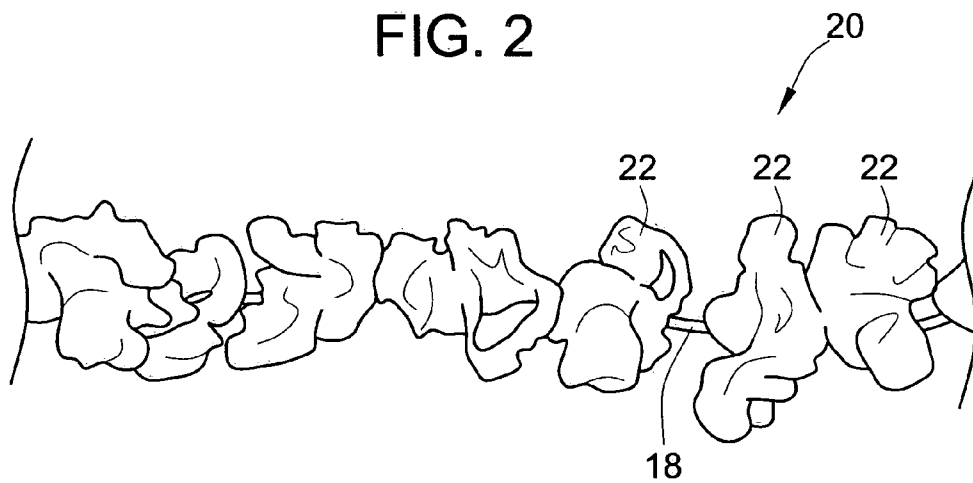

FIG. 3

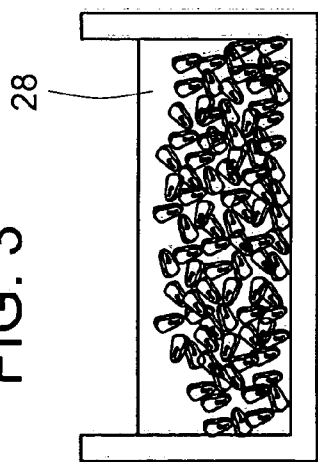

FIG. 4

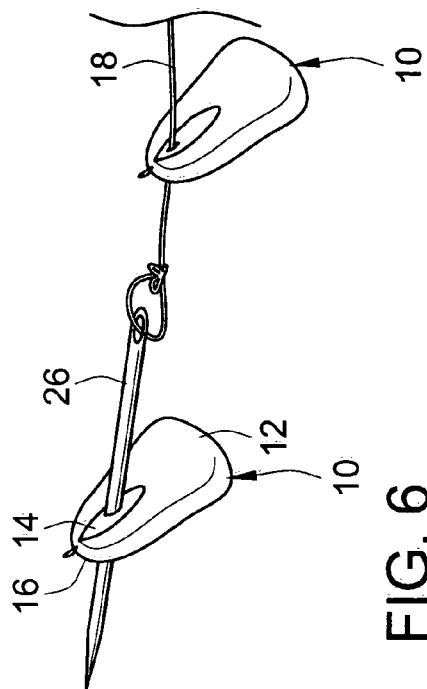

FIG. 5

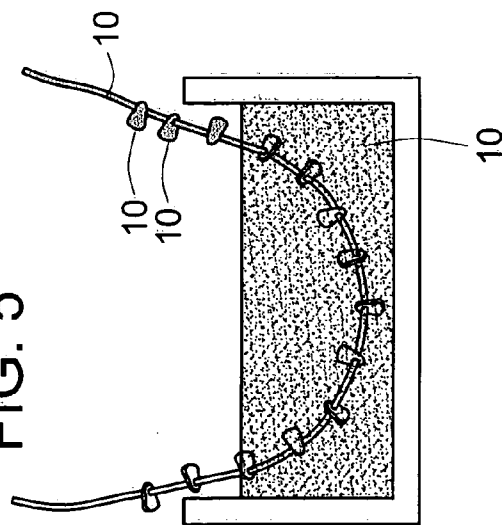

FIG. 6

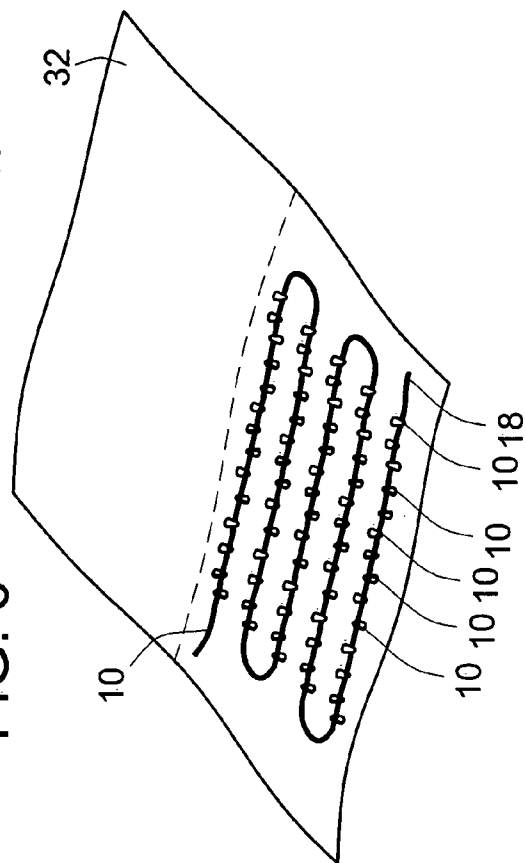
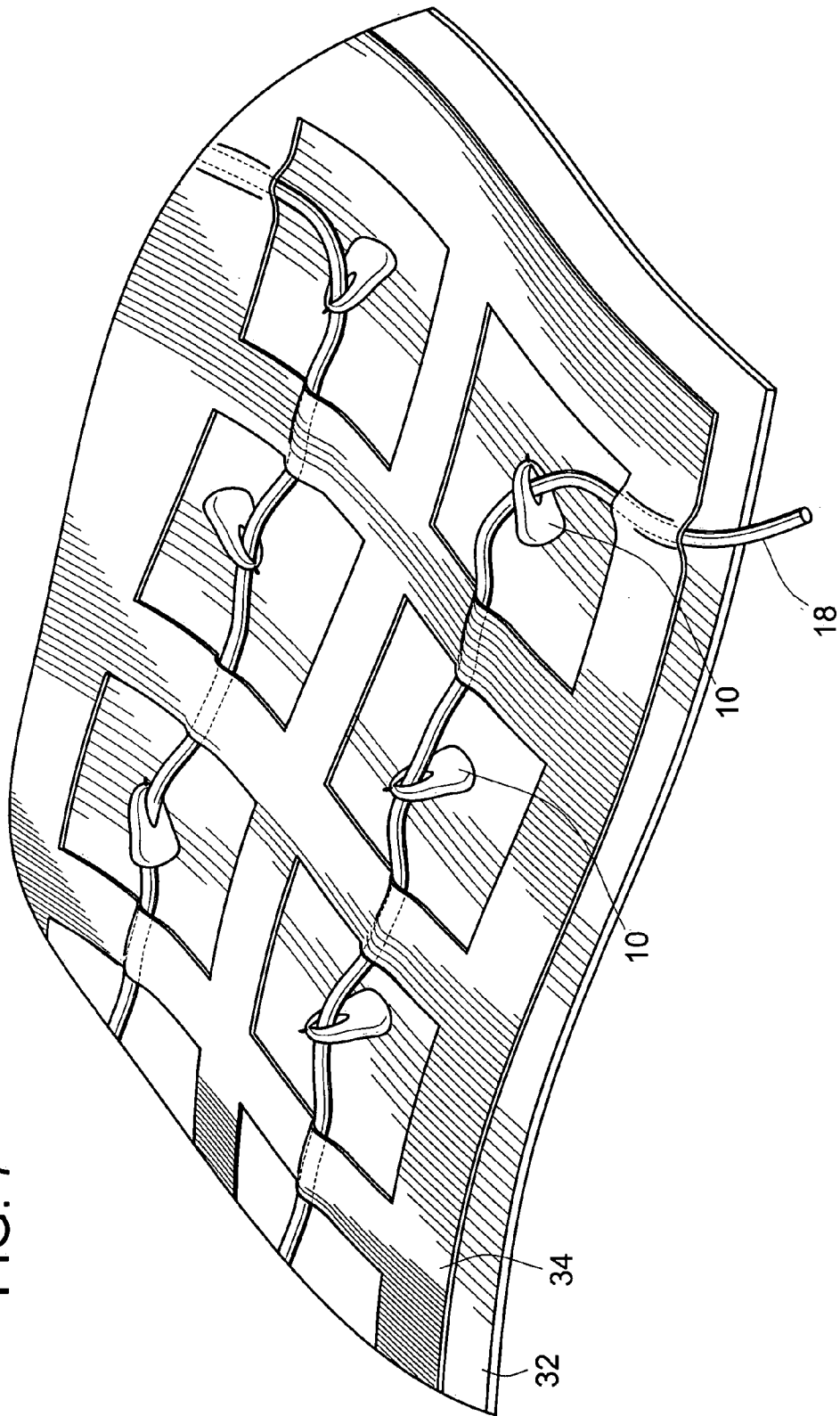

FIG. 7



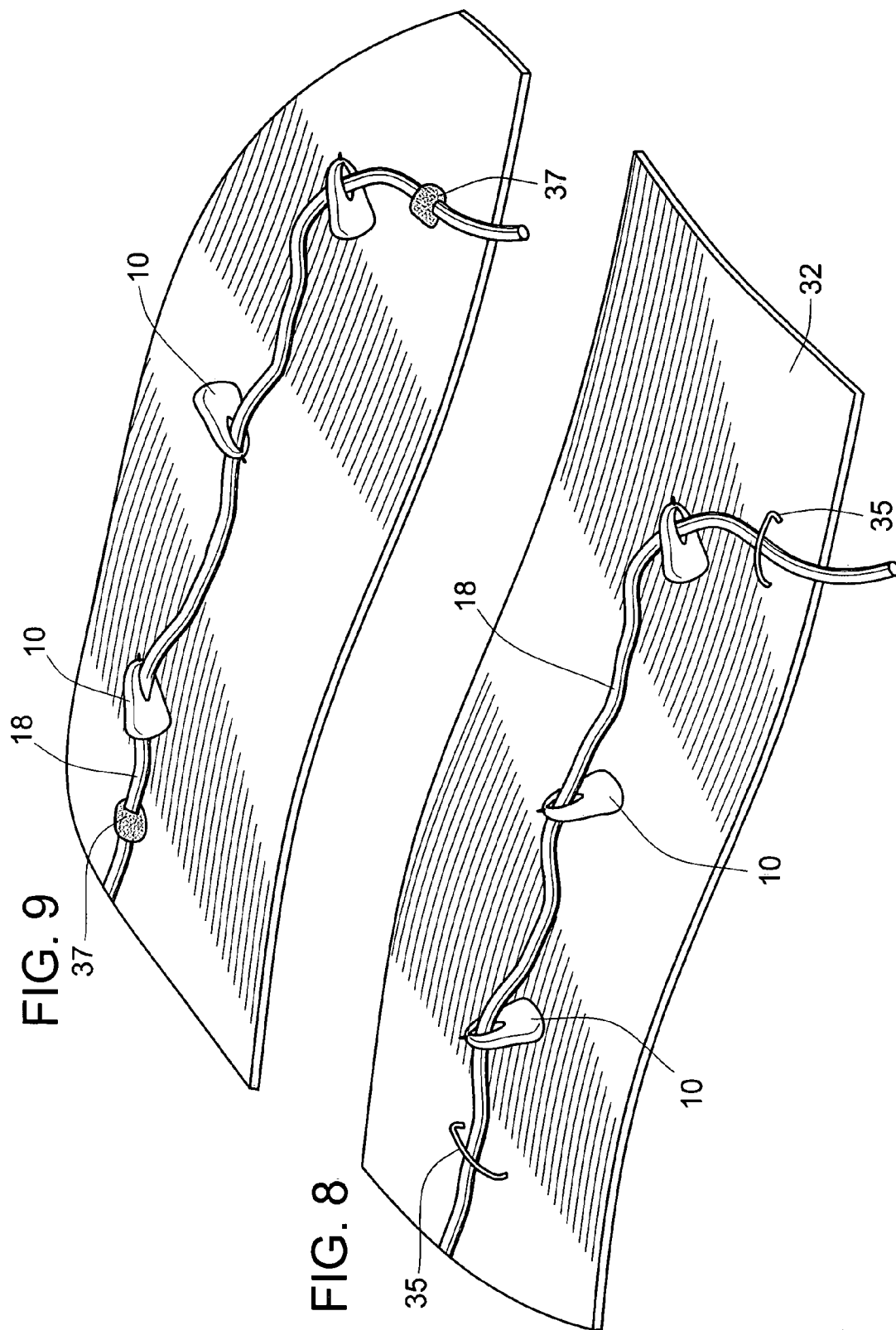
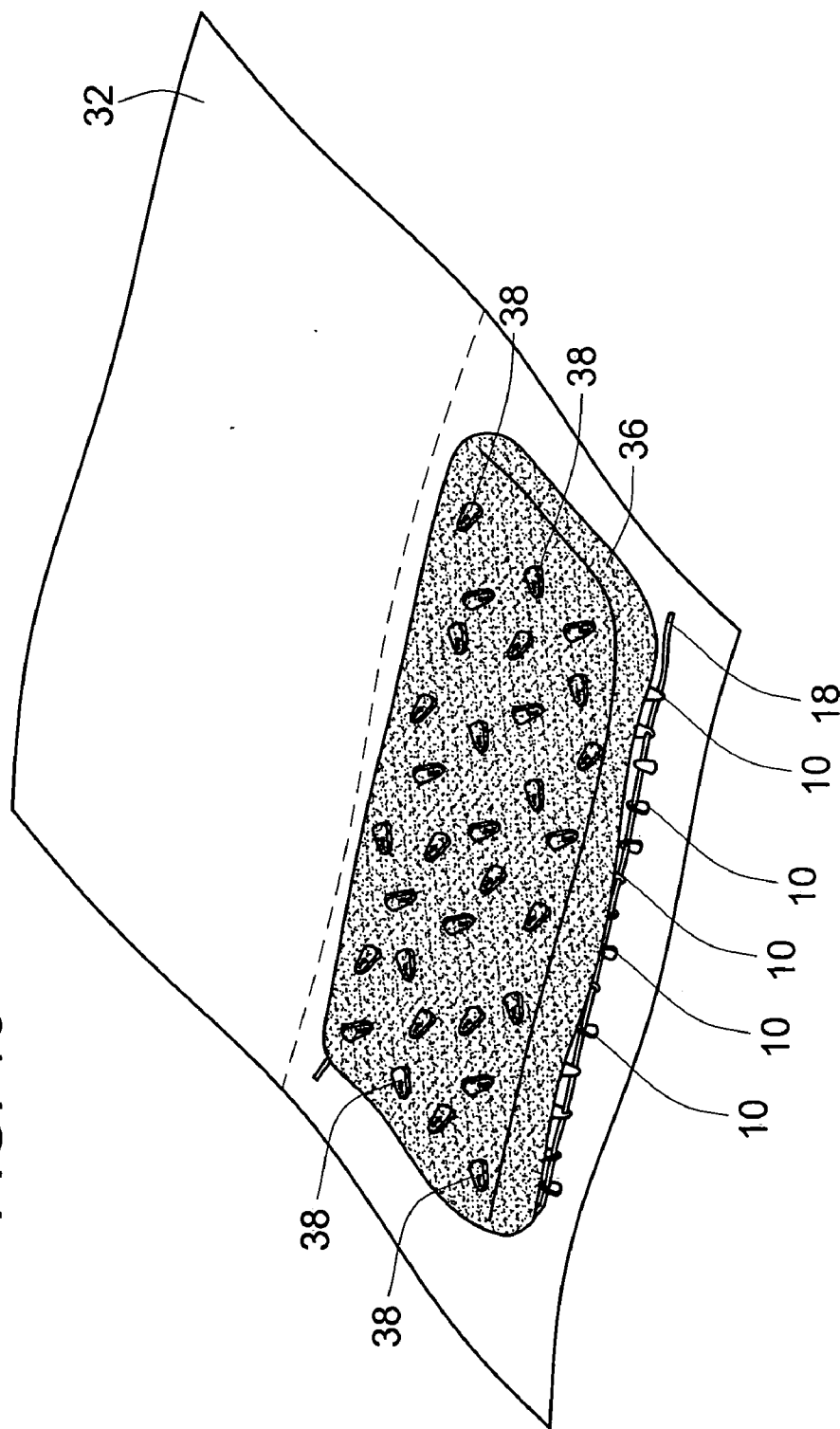

FIG. 10



STRUNG POPCORN SEEDS AND METHOD CONCERNING SAME

CROSS-REFERENCE TO RELATED PATENT APPLICATIONS

[0001] This patent application claims the benefit of U.S. Provisional Patent Application No. 60/448,730, filed Feb. 20, 2003, the entire disclosure of which is hereby incorporated by reference.

FIELD OF THE INVENTION

[0002] This invention pertains to the field of seeds and the like, and particularly to popcorn and the formation of popcorn garlands.

BACKGROUND OF THE INVENTION

[0003] Since the advent of microwave cooking, there has been an interest in popped corn. One use of popped corn, typically during the Christmas season, is to string popped corn to form a garland. Throughout history, and prior to the advent of the microwave, part of the preparation for holidays has included the ritual of stringing popped popcorn seeds. The ritual of stringing popcorn is tedious and can, in some cases can be impossible for individuals with handicaps or with little time. Moreover, a garland must be long enough for a given Christmas tree or whatever purpose for which the garland is created.

[0004] The invention provides such an efficient system and method for creating such strung garlands made of seeds. These and other advantages of the invention, as well as additional inventive features, will be apparent from the description of the invention provided herein.

BRIEF SUMMARY OF THE INVENTION

[0005] The present invention is directed broadly to methods and apparatus for creating a popcorn garland in which the seeds are strung on a string in an unpopped rather than a popped state. One aspect of the invention is therefore directed toward an apparatus for creating a string of popped seeds which comprises a plurality of unpopped seeds strung on a string.

[0006] Another aspect of the present invention is directed toward a method for making a string of seeds capable of popping that comprises string, a plurality of unpopped seeds on a string, and then spacing the seeds on the string to enable popping of the unpopped seeds.

[0007] A further aspect of the present invention is directed toward a method for creating a string of popped seeds that comprises placing a plurality of seeds strung on a string into a heating device and then applying heat to the plurality of seeds that are strung on this string to pop the seeds utilizing the heating device.

[0008] Other aspects, objectives and advantages of the invention will become more apparent from the following detailed description when taken in conjunction with the accompanying drawings.

BRIEF DESCRIPTION OF THE DRAWINGS

[0009] FIG. 1 illustrates unpopped seeds strung on a string according to an embodiment of the present invention.

[0010] FIG. 2 illustrates a string of popped seeds after applying heat to the string of unpopped seeds.

[0011] FIG. 3 is an illustration of an optional soak step for the seeds to facilitate easier piercing of popcorn seeds when stringing the seeds during manufacture.

[0012] FIG. 4 is a perspective illustration of the step of stringing popcorn seeds onto a string.

[0013] FIG. 5 is a schematic illustration of a step for sealing seeds on a string with grease to prevent moisture loss.

[0014] FIG. 6 is a perspective schematic illustration of a way to arrange seeds strung on a string into a microwavable bag.

[0015] FIGS. 7-9 are perspective illustrations of different type of retainer mechanisms which may be used to secure a string of popcorn seeds to the inside of a microwavable bag.

[0016] FIG. 10 is a perspective illustration of how grease and unstrung seeds may be added to the microwavable bag prior to enclosing the bag.

DETAILED DESCRIPTION OF THE INVENTION

[0017] There are many types of seeds that are capable of popping. Most of the types that “pop” are those that have an endosperm. Non-endospermic seeds digest an endosperm as it matures. As is known, the differences in seed morphology are often described in terms of the size of the seed embryo in relation to the seed’s endosperm. It is also known that seeds generally develop through three stages prior to an optimal time appropriate for “popping”. Specifically, a first stage is referred to as histo-differentiation. In this stage, an embryo forms. A second stage is referred to as a cell expansion stage. During this stage, food reserves are produced, such as in the endosperm. The third stage is referred to as a maturation stage, which typically is referred to as a drying stage.

[0018] One type of seed that includes a popping endosperm is a corn kernel such as the popcorn seeds 10 as shown. A corn kernel includes an endosperm 12 that typically takes up about 82% of a kernel’s dry weight and contains starch for germinating the seed. A corn kernel further includes a germ 14, which is located near the tip 16 of a kernel, where the attachment point of the kernel to the cob is located. The germ 14 contains enzymes, vitamins and mineral and approximately 25% of the germ is corn oil.

[0019] Referring now to FIG. 1, a string 18 of unpopped seeds 10 is illustrated in accordance with an embodiment of the present invention. According to the embodiment, a plurality of seeds 10 is strung prior to popping. The string 18 can be of any length, depending on the size of the heating vessel, desired length and requirements thereof. As shown in FIG. 1, the seeds can be popcorn seeds. However, as discussed above, any type of seed capable of popping is within the scope of the present invention. For example, endospermic seeds are within the scope of the invention.

[0020] Accordingly, a method according to one aspect of the invention is for creating a garland 20 of popped seeds 22 as shown in FIG. 2. More particularly, the method includes placing a plurality of unpopped seeds 10 on the string 18 in

a heating device such as a microwavable bag or other device and applying energy or heating the plurality of unpopped seeds **10**. The energy to apply to the unpopped seeds **10** can be via a microwave, such as microwave energy which when used with an appropriate heating vessel creates heat energy, or can be any other form of heat energy. For example, the string of unpopped seeds **10** can be placed in a popping apparatus or heating vessel, such as a pan or the like, or can be placed in a microwave cooking bag **24**.

[0021] Another aspect of the invention is directed to stringing a plurality of unpopped seeds **10** on a string **18** and organizing the seeds **10** on the string **18** to enable popping of the unpopped seeds **10** by applying heat. For example, a method can include stringing unpopped seeds **10**, such as popcorn kernels, and organizing the seeds **10** on the string **18** such that a garland **20** will be produced when energy is applied to the string of seeds. The organized string **18** of unpopped seeds **10** can then be placed in a microwavable bag **24**, tube or appropriate heating vessel for applying energy to the string of unpopped seeds.

[0022] As will be appreciated to those with the benefit of this disclosure, the spacing of the seeds, or the organization of the seeds on the string can be such that each seed is spaced to generate a garland of popped seeds independent of substantial visible string. Depending on the type of garland and the type of seed desired, the spacing can be altered for garland requirements. For example, for popcorn, in an embodiment, each seed is spaced at least $\frac{3}{8}$ inch apart from a next seed. A practical spacing for unpopped seeds **10** may be anywhere in the range of between about $\frac{1}{8}$ inch to about $1\frac{1}{4}$ inch (measured between the outer shells of adjacent seeds), although other appropriate spacing is possible. The plurality of seeds is organized on the string as a function of the average size of the unpopped seed and the minimum averaged popped size of the seeds and the desired resulting spacing of popped popcorn kernels on the string. For example, a seed with an average size of $\frac{1}{4}$ inch that pops to $\frac{1}{2}$ inch will be separated on a string to take into account the $\frac{1}{2}$ inch spacing and take into account the size of the unpopped seed, specifically, the space between each seed would be $\frac{1}{4}$ inch to produce a garland independent of substantial visible string.

[0023] Referring now to FIG. 2, a garland **20** comprising a string **18** of popped pre-strung kernels **22** is illustrated. The spacing of the seeds **10** on the string in FIG. 1 results in the desired spacing of popped kernels **22** illustrated in FIG. 2. To the extent old maids exist after popping, those may be crushed with a pair of pliers and adjustments to kernels can be made by manually sliding popped kernels along the string as desired to cover up gaps or the old maids also may be left on the string.

[0024] An aspect of the invention is further directed toward stringing the unpopped seeds via a manufacturing process. It has been discovered that stringing **18** through the germ **14** of a corn kernel seed **10** can cause the starch portion of the endosperm **12** to pop around the string **18**. It has further been discovered that stringing through the endosperm **12** of a corn kernel seed **10** can result in an appropriately popped kernel **22**. Since the germ **14** is softer and can more easily be pierced by a needle **26**, piercing primarily through the germ **14** is believed to be the preferred approach. A less preferred method may be to glue the

unpopped seeds on the string to thereby string the seeds in which the seeds may pop around the string.

[0025] Piercing the seed **10** is the preferred approach to securing seeds on a string. To facilitate easier piercing by a needle **26**, an optional first step may be to first soften the seed such as by soaking the seeds in a liquid such as water **28** as is shown for example in FIG. 3. A relatively short soak time may not appreciably increase the moisture content of the seed (which is optimally about 13-15% to facilitate popping). For example, a water soak of about one to eight minutes if the water **28** is lukewarm can appreciably soften the seed to facilitate easier piercing by a needle **26**. However, the germ is also typically soft enough to allow piercing without a soaking step as illustrated in FIG. 3 and the seeds **10** can be pierced by a needle **26** without this soaking step. Alternatively, other forms of stringing may be conducted such as drilling, gluing seeds or otherwise which may also not benefit from an initial soaking step.

[0026] Another initial step may be to first seal the string **18** with a grease such as paraffin, sealant or other wax to seal the string **18** to prevent the string from acting as a wick. This step also serves to assist in locating and registering seeds **10** at spaced intervals during stringing and then registering popped seeds on the garland **20**.

[0027] Turning to FIG. 4, the seeds **10** whether first soaked or unsoaked, can be strung onto the string **18** utilizing a needle **26** having the string **18** attached thereto. Preferably, the needle **26** is directed through the germ **14** of the popcorn seeds **10** as that is the softest part of the seeds **10**. As the piercing can be done at an angle as shown for example in FIG. 4 such that substantially all of the needle **26** goes through the germ **14** and little or none of the endosperm **12**. It is also possible to pierce the seeds through the endosperm.

[0028] The stringing step as shown in FIG. 4 can either be done manually or preferably through an automated process such as by organizing the seeds in a line on a belt, vibration table, sticky surface or otherwise, in which the relative advancement between the needle **26** and the seeds **10** occurs automatically. After the seeds **10** are strung on the string **18**, if necessary (for example if the seeds are soaked in liquid as shown in FIG. 3), the moisture content of the seeds may be adjusted to be at or near the optimal range suitable to facilitate popping of the popcorn seeds **10**. As evident from the above, if no soaking or little soaking is done, then no drying step or moisture adjustment may be necessary. In either event, it is then preferable to seal coat the seeds as schematically shown in FIG. 5 in which a sealant such as grease (e.g. grease is meant to be broad and includes vegetable oil, animal fat, paraffin, other waxes, or other types of grease or other such sealant that prevents water release) can be coated over the seeds and preferably the string **18** (which may act as a wick if made of cotton or other wick like material). The grease encapsulates the seeds **10** and string **18** to prevent moisture loss and also extends shelf life. The sealant may be applied such as by dipping the string **18** of seeds **10** in a vat of the grease **30** as is shown, or may be done by spray on, brushed on or other appropriate techniques.

[0029] Once the string **18** of popcorn seeds **10** is sealed with an appropriate grease **30** or other appropriate sealant, the string **18** of popcorn seeds **10** can then be arranged in an

organized manner in a suitable package such as a microwavable bag **32** as shown. A microwavable bag may include a susceptor foil (not shown), which more quickly converts microwave energy into heat energy and more evenly disperses the heat to the grease and the seeds.

[0030] After the seeds **10** and string **18** are placed into the bag, the seeds **10** may be attached to the microwavable bag **32** by any suitable retainer such as an overlay **34** as shown in FIG. 7, staples **35** as shown in FIG. 8, glue beads **37** or other such suitable retainer structure. The retainers secure the string to the bag at spaced intervals (e.g. preferably every 1-5 seeds) at strategic locations in order to ensure that when kernels pop during subsequent microwaving operations that a popped kernel does not pull other seeds out of contact with the receptor foil or heated grease and thereby cause excessive production of old maids. In addition, the retainers assist in preventing tangling of the string since there is no way to predict which seed will pop first since popping of seeds is a random occurrence. The retainer such as the paper overlay **34** can be overcome with manual force such as by breaking the web with the string **18** to allow easy pull out of the string **18** from the bag after popping is conducted and facilitates removal of the string **18** from the microwavable bag **32** in an organized manner.

[0031] Further steps according to the invention may include applying additional grease **36** into the microwavable bag to facilitate popping of the popcorn seeds **10**. The sealant and applying grease steps may also be combined into a single step if desired. Optionally, some unstrung seeds **38** may be provided among the grease **36** such that when the product is used, there will not only be strung popcorn kernels but also popcorn for eating as well. The microwavable bag **12** is then sealed up in a conventional manner to enclose the string of popcorn seeds and the unstrung seeds if any for end user use.

[0032] The string used to string the seed can be configured to be energy resistant for the type of energy to be applied to the unpopped seeds. For example, a microwave resistant string includes cotton string or other appropriate string material.

[0033] Hooks or other attachment means may be provided integral with the string or provided with the popcorn packaging to facilitate attachment of adjacent strings and/or to attach to objects around the house.

[0034] The use of the terms “a” and “an” and “the” and similar referents in the context of describing the invention (especially in the context of the following claims) are to be construed to cover both the singular and the plural, unless otherwise indicated herein or clearly contradicted by context. The terms “comprising,” “having,” “including,” and “containing” are to be construed as open-ended terms (i.e., meaning “including, but not limited to,”) unless otherwise noted. Recitation of ranges of values herein are merely intended to serve as a shorthand method of referring individually to each separate value falling within the range, unless otherwise indicated herein, and each separate value is incorporated into the specification as if it were individually recited herein. All methods described herein can be performed in any suitable order unless otherwise indicated herein or otherwise clearly contradicted by context. The use of any and all examples, or exemplary language (e.g., “such as”) provided herein, is intended merely to better illuminate

the invention and does not pose a limitation on the scope of the invention unless otherwise claimed. No language in the specification should be construed as indicating any non-claimed element as essential to the practice of the invention.

[0035] Preferred embodiments of this invention are described herein, including the best mode known to the inventors for carrying out the invention. Variations of those preferred embodiments may become apparent to those of ordinary skill in the art upon reading the foregoing description. The inventors expect skilled artisans to employ such variations as appropriate, and the inventors intend for the invention to be practiced otherwise than as specifically described herein. Accordingly, this invention includes all modifications and equivalents of the subject matter recited in the claims appended hereto as permitted by applicable law. Moreover, any combination of the above-described elements in all possible variations thereof is encompassed by the invention unless otherwise indicated herein or otherwise clearly contradicted by context.

What is claimed is:

1. An apparatus for creating a string of popped seeds, comprising a plurality of unpopped seeds strung on a string.
2. The apparatus of claim 1, wherein the seeds comprise a plurality of corn seeds.
3. The apparatus of claim 2, wherein the plurality corn seeds are spaced at least about $\frac{1}{8}$ inch apart on the string.
4. The apparatus of claim 3, wherein the corn seeds are spaced no greater than about $\frac{1}{4}$ inches apart on the string.
5. The apparatus of claim 1, further comprising a microwavable package containing the string and the seeds.
6. The apparatus of claim 5, further comprising grease arranged in the microwavable package for facilitating popping of seeds.
7. The apparatus of claim 6, wherein the seeds comprise a plurality of corn seeds, and wherein the string is arranged in a predetermined organized manner.
8. The apparatus of claim 6, further comprising at least one retainer securing the string and the corn seeds to the microwavable package.
9. The apparatus of claim 1, further comprising a sealant encapsulating the seeds and the string to prevent loss of moisture from the seeds.
10. The apparatus of claim 9, wherein the sealant comprises a wax.
11. The apparatus of claim 1, wherein the plurality of seeds have a predetermined water content suitable to facilitate popping, such that when heat is applied to the plurality of seeds, the seeds pop and form popped kernels.
12. A method for making a string of seeds capable of popping, comprising:
 - stringing a plurality of unpopped seeds on a string; and
 - spacing the seeds on the string to enable popping of the unpopped seeds.
13. The method of claim 12 wherein the stringing is done through a germ portion of the seeds.
14. The method of claim 12 wherein the seeds are corn seeds.
15. The method of claim 14 wherein the spacing comprises separating the seeds between about $\frac{1}{8}$ inch and about $\frac{1}{4}$ inch apart on the string.

16. The method of claim 12, further comprising packaging the seeds in a microwavable package with grease arranged therein suitable for facilitating popping of the seeds when heated.

17. The method of claim 16, further comprising retaining the string to the package at selected locations to facilitate contact between the grease and the seeds when heat is applied and seeds start to pop in random manner.

18. The method of claim 16, further comprising retaining the string to the package in an organized manner such that when the seeds are popped due to heat application, the popped seeds are organized for a predetermined removal from the package.

19. The method of claim 16, wherein the seeds are corn seeds, further comprising maintaining the moisture content of the corn seeds at or near optimal popping moisture content to facilitate later popping of substantially all of the corn seeds when heat is applied.

20. The method of claim 19, further comprising arranging a plurality of unstrung corn seeds in the microwavable package in addition to the strung corn seeds.

21. The method of claim 12, wherein said stringing includes forming a hole in the seeds, further comprising sealing the hole in the seeds to prevent moisture loss from the seeds.

22. The method of claim 12, further comprising soaking the seeds with a liquid to soften the seeds prior to the stringing step.

23. The method of claim 19, further comprising drying the seeds to a predetermined average moisture content in the seeds suitable for enabling popping of the seeds.

24. The method of claim 12 wherein the stringing comprises piercing through a corn seed with need having the string attached thereto.

25. A method for creating a string of popped seeds, the method comprising:

placing a plurality of seeds strung on a string into a heating device; and

heating the plurality of seeds strung on a string to pop the seeds with the heating device.

26. The method of claim 25, wherein said heat comprises microwaving a package having a susceptor foil for converting microwave energy into heat.

27. The method of claim 26, further comprising removing the string of seeds from the package by breaking a plurality of retainers securing the string to the package.

28. The method of claim 25, further comprising arranging the string of seed after popping on a Christmas tree.

* * * * *