



US 20080067900A1

(19) **United States**

(12) **Patent Application Publication**
Marshall et al.

(10) **Pub. No.: US 2008/0067900 A1**

(43) **Pub. Date: Mar. 20, 2008**

(54) **MODULAR FOOD SERVICE SYSTEM AND METHOD**

Publication Classification

(75) Inventors: **John J. Marshall**, Ennismore (CA); **David L. Hancock**, Winfield, IL (US); **Roger G. Ruffin**, Milwaukee, WI (US); **Russell V. Brownlow**, Vernon, TX (US)

(51) **Int. Cl.**
A47B 47/00 (2006.01)
A47B 77/00 (2006.01)
(52) **U.S. Cl.** **312/108; 312/111**

(57) **ABSTRACT**

A modular system and method are disclosed. The system comprises a first unit, a second unit, and a connector for coupling the first unit and the second unit. The first unit has a first upper projection and a first lower projection, and the second unit has a second upper projection and a second lower projection. The connector comprises upper lower tracks. Both the upper and lower tracks have a slot and an engagement guide configured to receive and to guide the projections into a sliding engagement with the slots. The first unit is coupled to the second unit by positioning the first unit proximate the second unit so that the upper and lower projections are proximate each other; aligning the engagement guides and the slots with the projections; and moving the connector so that the engagement guides guide the projections into engagement with the tracks and slide into the slots.

Correspondence Address:
FOLEY & LARDNER LLP
777 EAST WISCONSIN AVENUE
MILWAUKEE, WI 53202-5306

(73) Assignee: **MCK, LLC**
(21) Appl. No.: **11/715,156**
(22) Filed: **Mar. 7, 2007**

Related U.S. Application Data

(60) Provisional application No. 60/845,656, filed on Sep. 19, 2006.

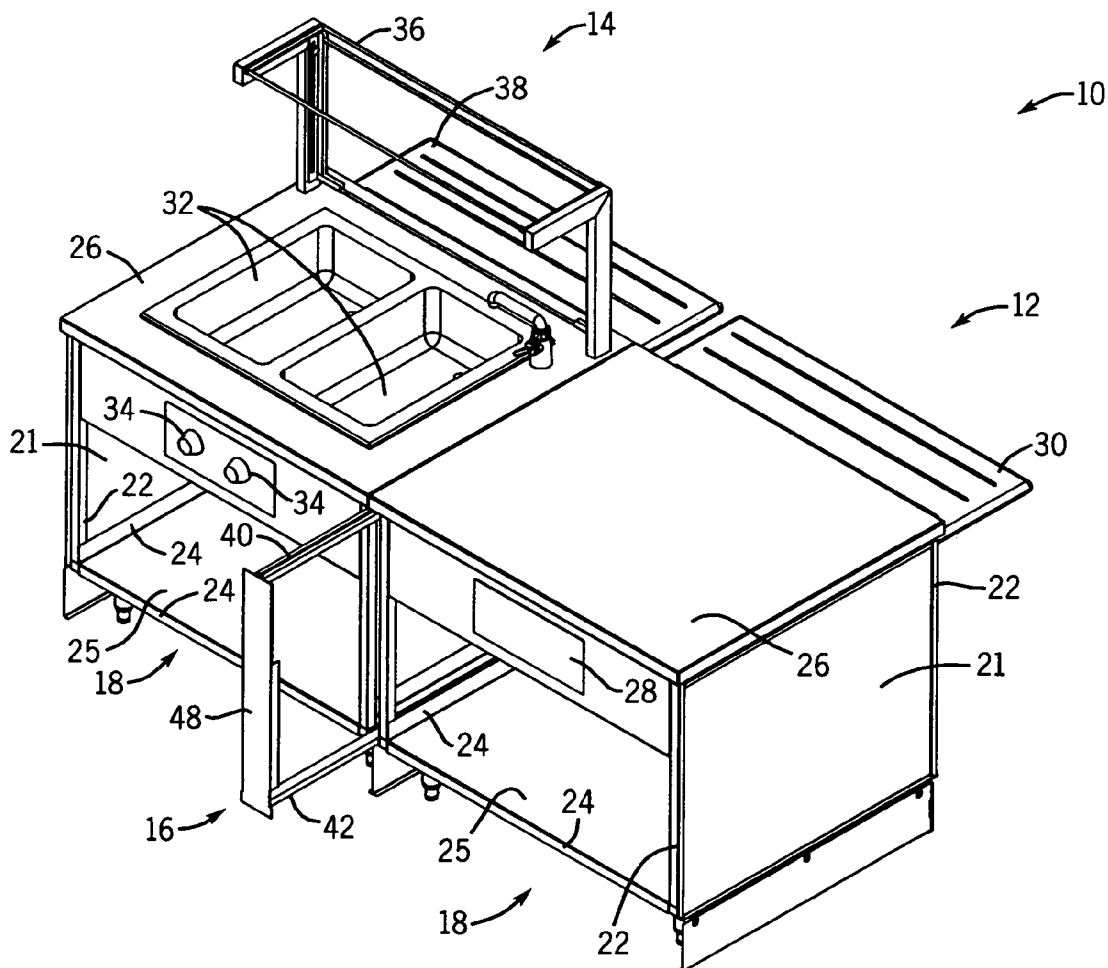

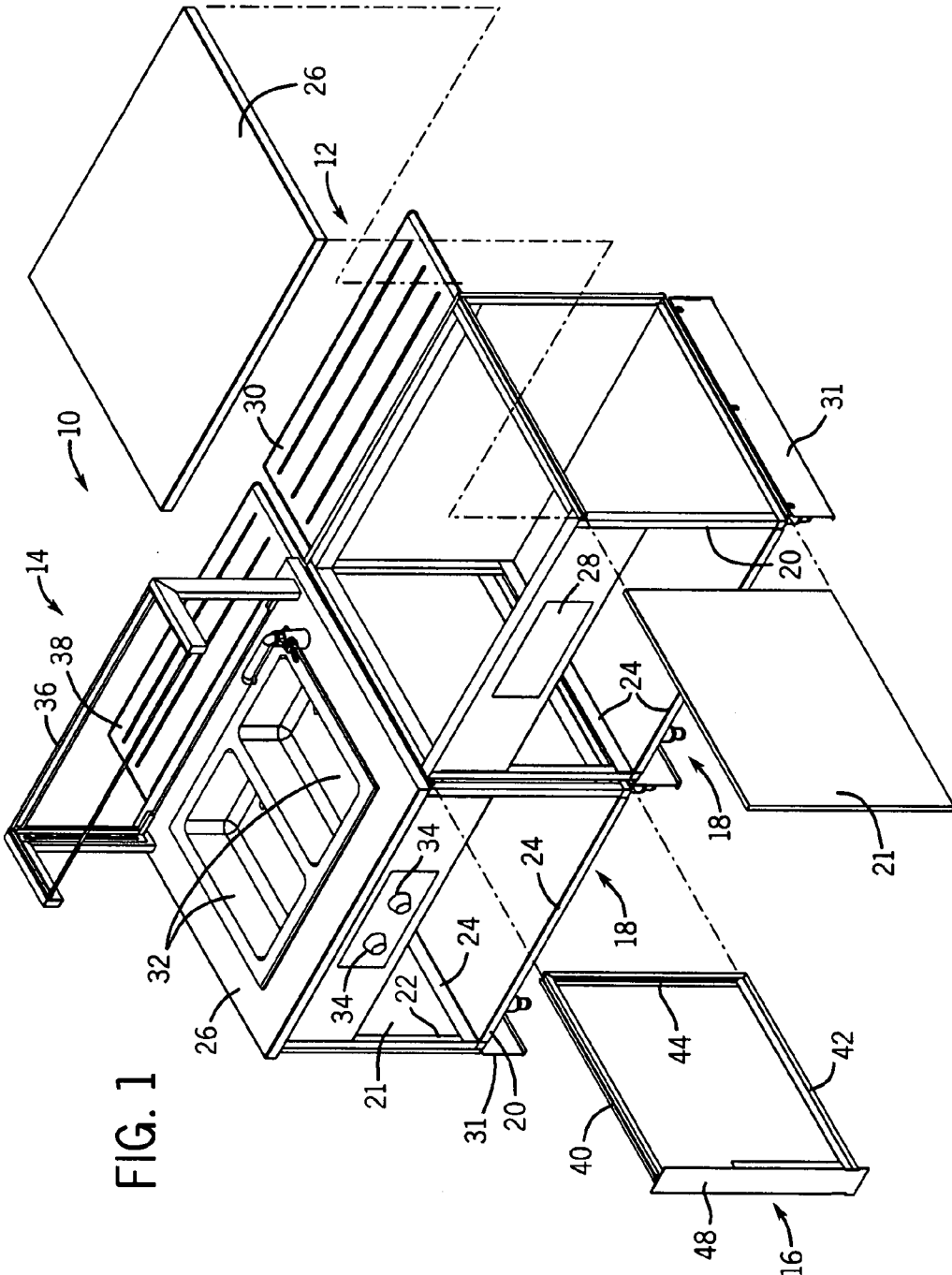
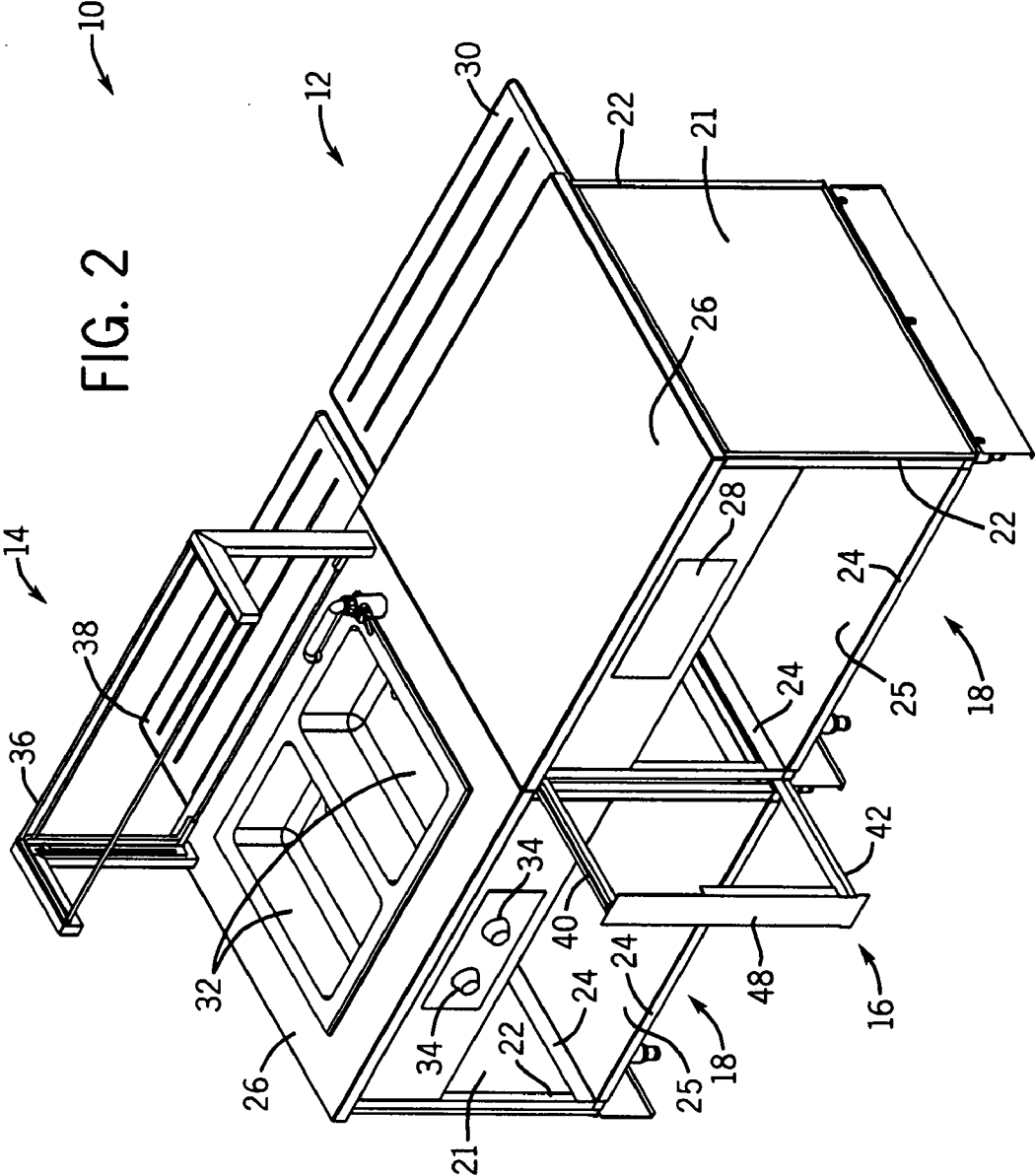
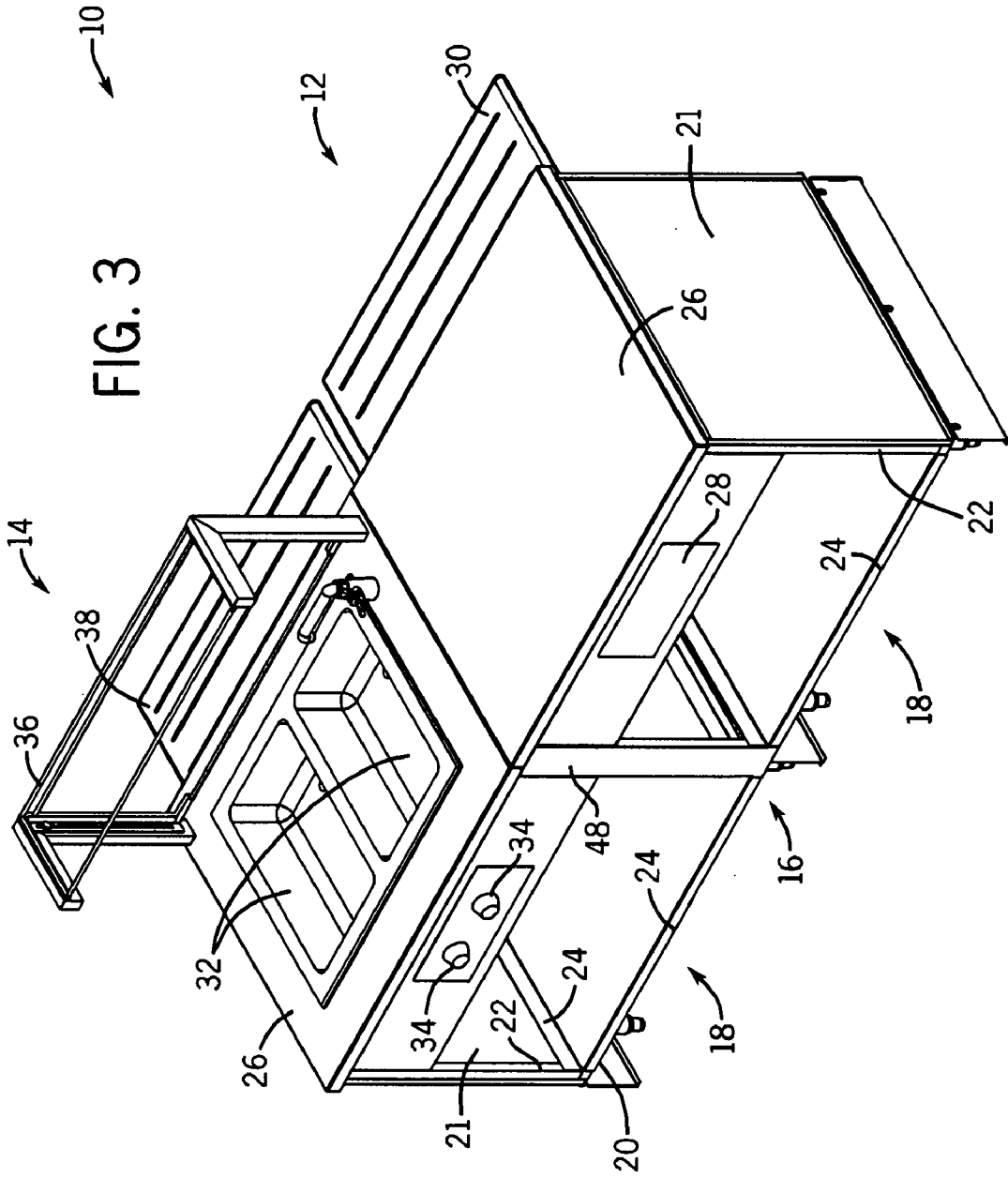
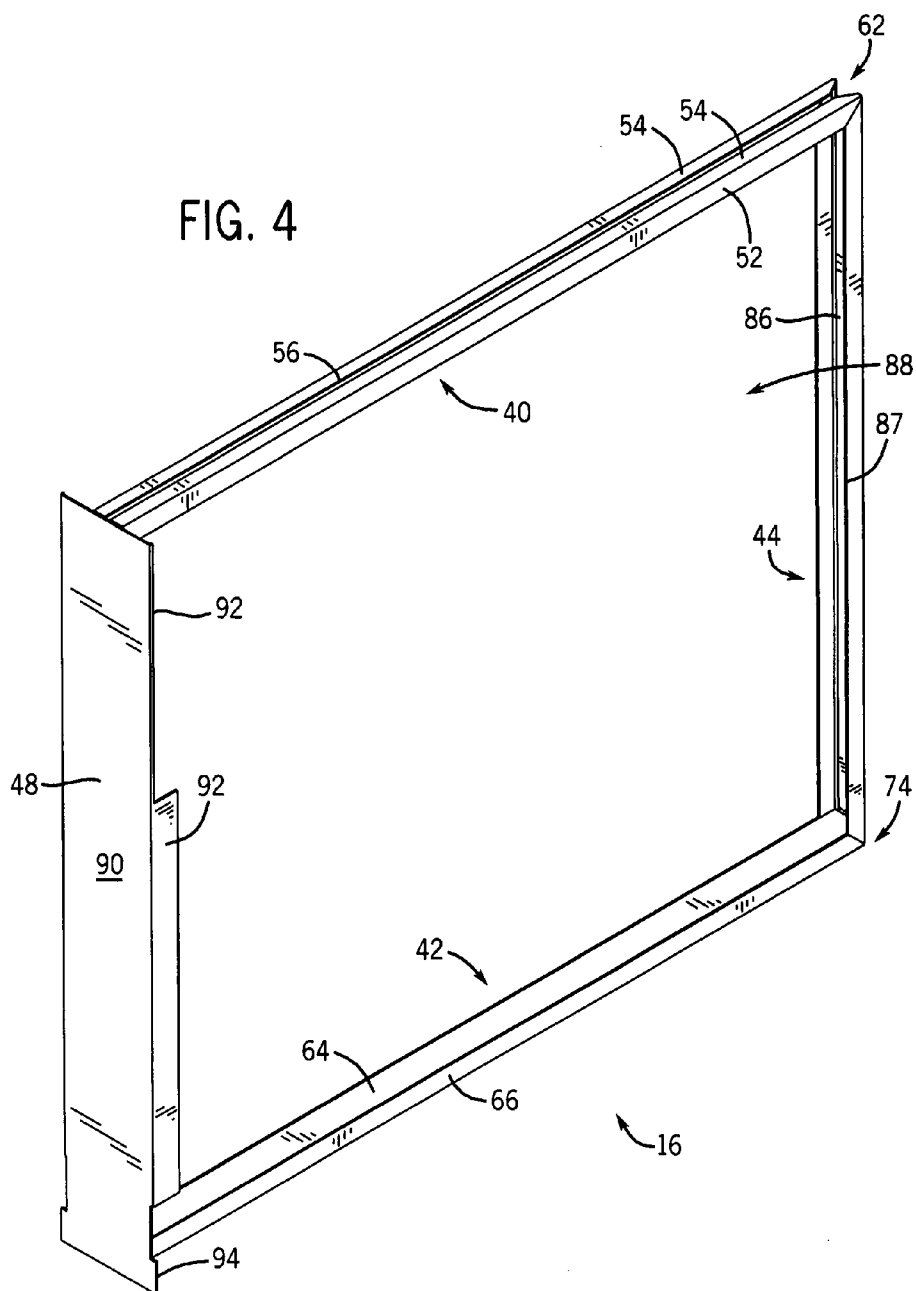

FIG. 1







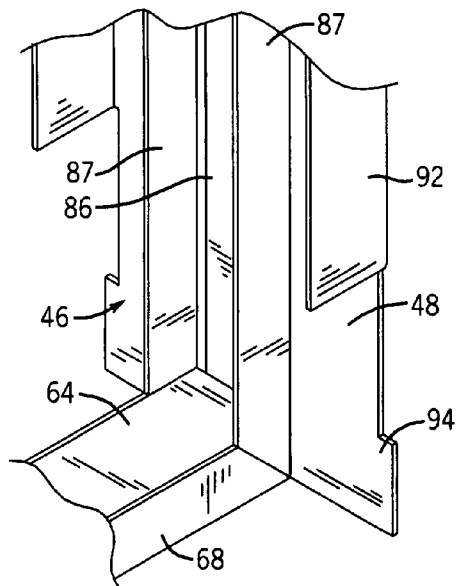

FIG. 5

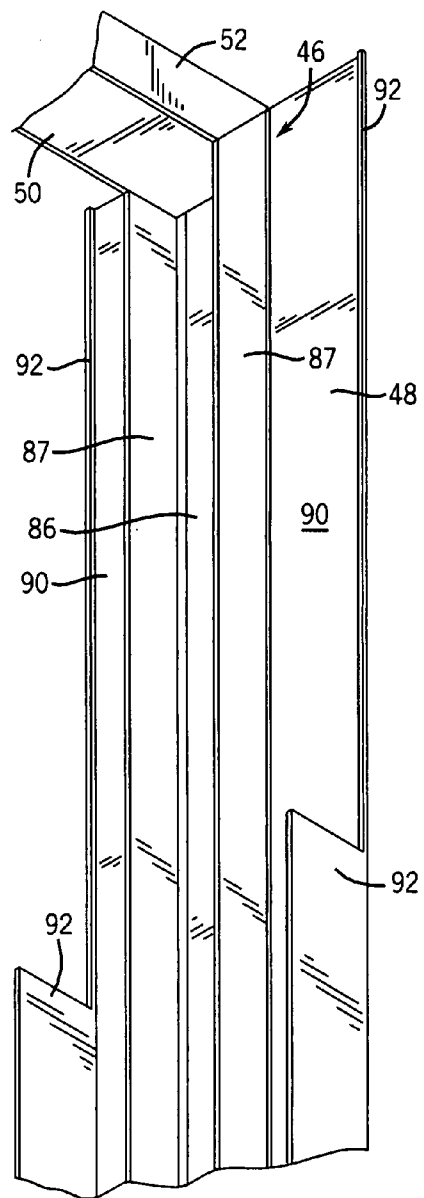

FIG. 6

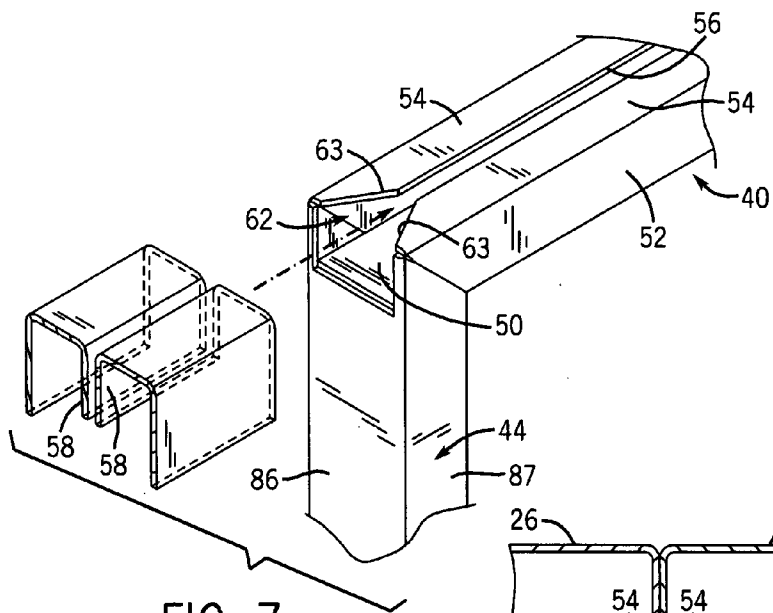

FIG. 7

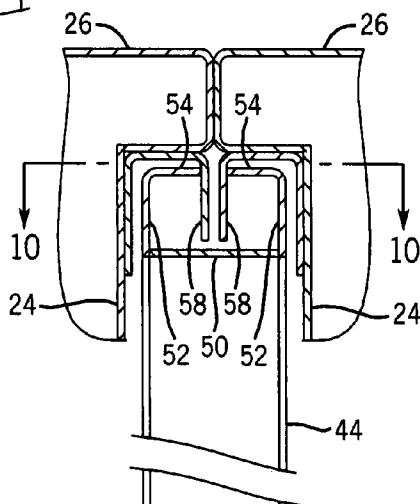
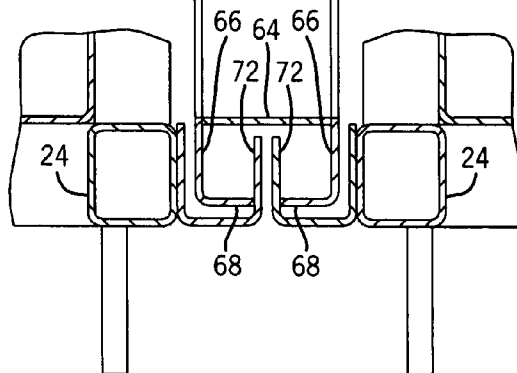

FIG. 8



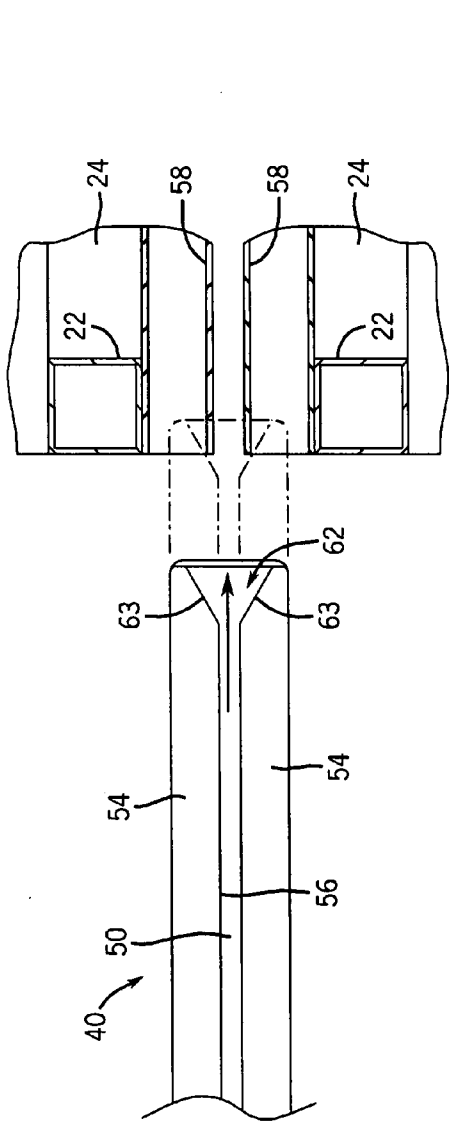

FIG. 9

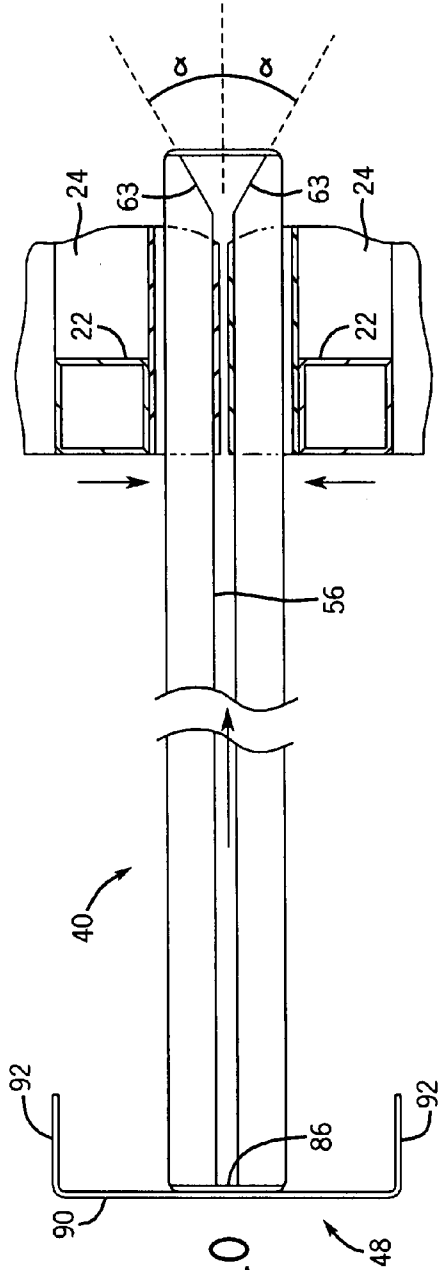
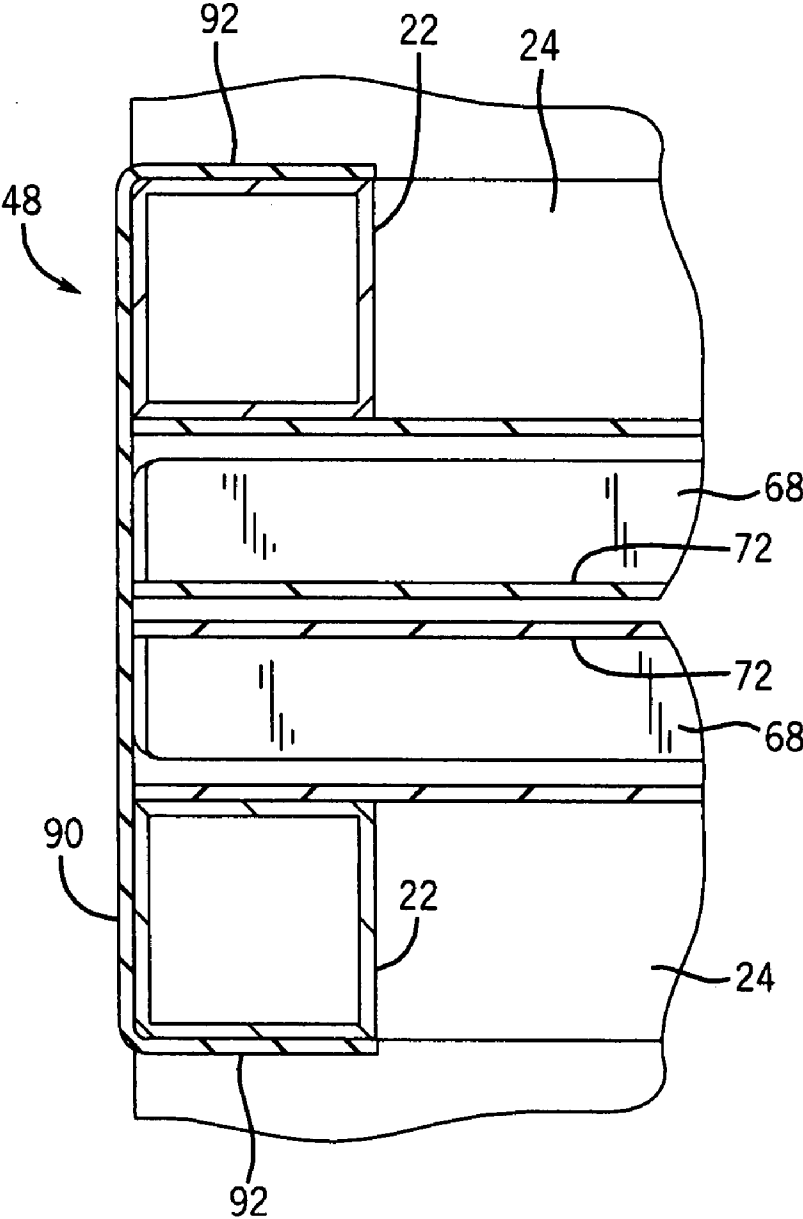

FIG. 10

FIG. 11



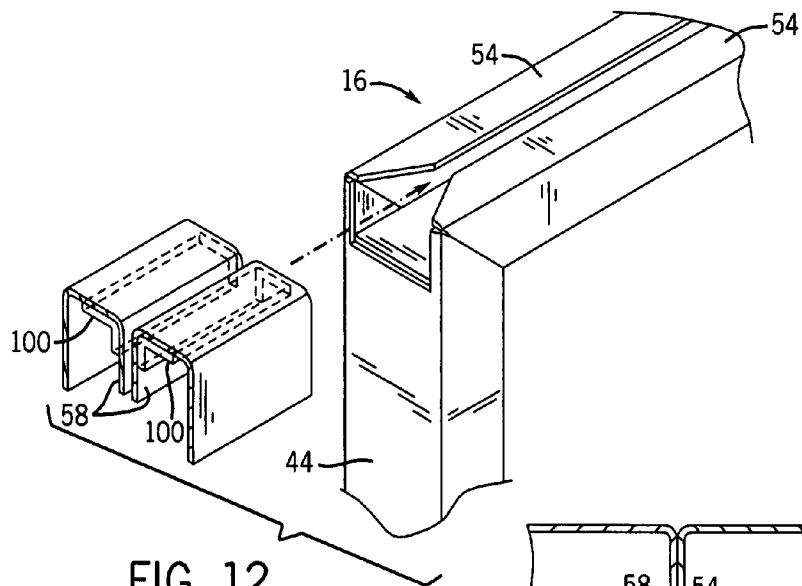

FIG. 12

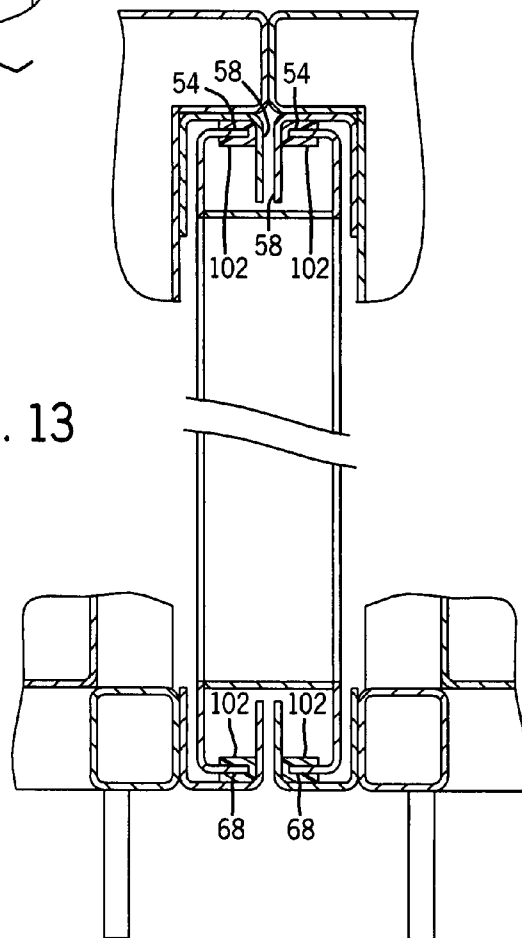

FIG. 13

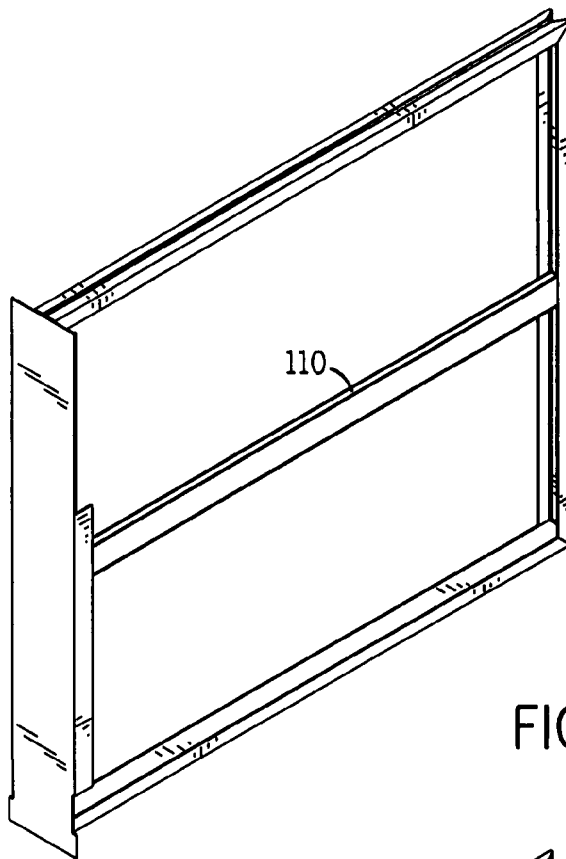

FIG. 14

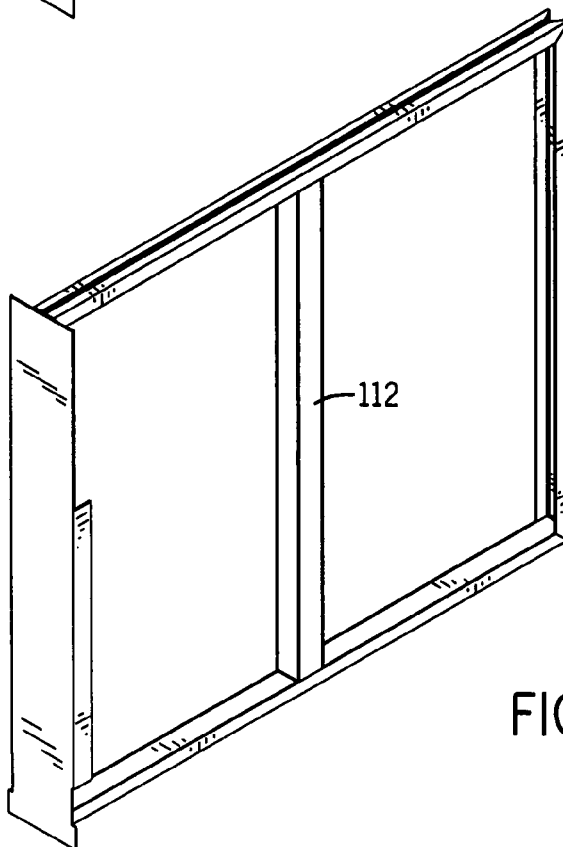

FIG. 15

MODULAR FOOD SERVICE SYSTEM AND METHOD

CROSS-REFERENCE TO RELATED APPLICATIONS

[0001] The present application claims priority under 35 U.S.C. §119 from U.S. Provisional Patent Application No. 60/845,656 titled "MODULAR FOOD SERVICE SYSTEM AND METHOD" filed Sep. 19, 2006 (Attorney Docket No. 071045-0146), the full disclosure of which is hereby incorporated herein by reference.

BACKGROUND

[0002] The present application relates to a modular service system. More specifically, the present application relates to a link or coupling member for connecting sectional units of a modular food service system.

[0003] It is generally known to provide food service systems. Such known food service systems typically include multiple sectionals or units that are connected together by fasteners, brackets, or the like. However, such known systems has several disadvantages including substantial effort needed to precisely align the units for assembly/attachment, as well as substantial effort needed to reconfigure or separate the units due to the fasteners and brackets used. As such, breaking down the system to reconfigure, store, or relocate it is a difficult activity. As such, multiple systems or customized systems are purchased and installed at a greater expense than if a single system could be quickly and easily assembled, disassembled, reconfigured, stored, relocated, or the like.

[0004] Accordingly, it would be advantageous to provide a modular service system that is readily, quickly, and easily assembled, disassembled, configured, reconfigured, or the like. It would also be advantageous to provide a link or coupling member for connecting sectional units of a modular food service system. It would further be advantageous to provide a connector link that assists in aligning and coupling the adjacent units and reduces or minimizes the effort required to install. It would be desirable to provide for a modular service system having one or more of these or other advantageous features. To provide an inexpensive, reliable, and widely adaptable link or coupling member for connecting sectional units of a modular food service system that avoids the above-referenced and other problems would represent a significant advance in the art.

SUMMARY

[0005] The present invention relates to a modular food service system comprising a first food service unit, a second food service unit, a connector for coupling the first food service unit to the second food service unit. The first food service unit has a first upper projection and a first lower projection, and the second food service unit has a second upper projection and a second lower projection. The connector comprises an upper track and a lower track. The upper track has a slot and an engagement guide configured to receive and guide the first upper projection and the second upper projection into a sliding engagement with the slot. The lower track has a slot and an engagement guide configured to receive and guide the first lower projection and the second lower projection into a sliding engagement with the slot. The first food service unit is coupled to the second food service

unit by the upper track engaging the first upper projection and the second upper projection, and by the lower track engaging the first lower projection engaging the second lower projection.

[0006] The present invention also relates to a connector for coupling a first modular unit to a second modular unit. The first modular unit has a first upper projection and a first lower projection and the second modular unit has a second upper projection and a second lower projection. The connector comprises a front member, a rear member, an upper track, and a lower track. The upper track extends between upper portions of the front member and the rear member, and has a slot and an engagement guide configured to receive and to guide the first upper projection and the second upper projection into a sliding engagement with the slot. The second track extends between lower portions of the front member and the rear member, and has a slot and an engagement guide configured to receive and to guide the first lower projection and the second lower projection into a sliding engagement with the slot. The first modular unit is coupled to the second modular unit by the upper track engaging the first upper projection and the second upper projection, and the lower track engaging the first lower projection engaging the second lower projection.

[0007] The present invention further relates to a method for configuring, reconfiguring, or installing a modular system. The method comprises providing a first modular unit and a second modular unit. The first modular unit has a first upper projection and a first lower projection, and the second modular unit has a second upper projection and a second lower projection. The method also comprises providing a connector having an upper track and a lower track. The upper track has an upper slot and an upper engagement guide. The lower track has a lower slot and a lower engagement guide. The method further comprises positioning the first modular unit proximate the second modular unit so that the first upper projection is proximate the second upper projection and the first lower projection is proximate the second lower projection; aligning the engagement guide and the slot of the upper track with the first upper projection and the second upper projection; aligning the engagement guide and the slot of the lower track with the first lower projection and the second lower projection; and coupling the first modular unit to the second modular by moving the connector so that the upper engagement guide guides the first upper projection and the second upper projection into engagement with the upper track and slides into the upper slot and the lower engagement guide guides the first lower projection and the second lower projection into engagement with the lower track and slides into the lower slot.

[0008] The present invention further relates to various features and combinations of features shown and described in the disclosed embodiments. Other ways in which the objects and features of the disclosed embodiments are accomplished will be described in the following specification or will become apparent to those skilled in the art after they have read this specification. Such other ways are deemed to fall within the scope of the disclosed embodiments if they fall within the scope of the claims which follow.

BRIEF DESCRIPTION OF THE DRAWINGS

[0009] FIGS. 1-3 are perspective views of a modular units being coupled by a connector.

[0010] FIG. 4 is a perspective view of the connector of FIG. 1.

[0011] FIGS. 5 and 6 are fragmentary perspective views of the connector of FIG. 4.

[0012] FIG. 7 is an exploded fragmentary perspective view of the connector and projections on separate modular sectional units.

[0013] FIG. 8 is a section view of the engagement between the sectional units and the connector taken along the line 8-8 in FIG. 2.

[0014] FIG. 9 is a fragmentary top sectional view showing the connector engaging a pair of sectional units.

[0015] FIG. 10 is a fragmentary sectional view following engagement shown in FIG. 9 and taken along the line 10-10 in FIG. 8.

[0016] FIG. 11 is a fragmentary sectional view of the connector coupling a pair of sectional units taken along line 11-11 in FIG. 3.

[0017] FIG. 12 is an exploded fragmentary perspective view of the connector and projections on separate modular sectional units according to an alternative embodiment.

[0018] FIG. 13 is a section view of the engagement between the sectional units and the connector according to an alternative embodiment.

[0019] FIG. 14 is a perspective view of a connector according to an alternative embodiment.

[0020] FIG. 15 is a perspective view of a connector according to an alternative embodiment.

DETAILED DESCRIPTION OF THE PREFERRED AND EXEMPLARY EMBODIMENTS

[0021] FIGS. 1-3 show a modular food service system 10 according to an exemplary embodiment. Modular food service system 10 includes a first unit 12, a second unit 14, and a connector 16 coupling first unit 12 and second unit 14. Connector 16 is removable so that units 12, 14 may be reconfigured, relocated, or the like. System 10 is shown for use with a food service environment, but a person having ordinary skill in the art would recognize that the units and connector may be used in any of a variety of non-food service environments where it is desirable to have a modular arrangement. Also, system 10 is shown as having two sectional units, but a person having ordinary skill in the art would recognize that any number of sectional units may be used and coupled together by connectors in any of a variety of configurations.

[0022] Units 12, 14 (e.g., sectionals, stations, etc.) each include a base 18 and other features or components described further below and/or shown in the FIGURES. Base 18 includes a frame 20 and a plurality of panels 21. Frame 20 provides structural support for units 12, 14 and includes a plurality of vertical support members 22 and a plurality of horizontal support members 24. According to an exemplary embodiment, four vertical members 22 are located at corners of base 18 and are coupled at their ends by eight horizontal members 24. Vertical members 22 and/or horizontal members 24 are preferably tubes with a square cross-section. Alternatively, the members may have other cross-sections (e.g., circular, rectangular, etc.), may be solid, hollow, or the like.

[0023] Panels 21 are coupled to frame 20 to provide a barrier to inhibit access (e.g., visual, physical, etc.) to the inside area or space of base 18, to provide contamination

protection to/from the space, and to provide a decorative outer surface to units 12, 14. According to a preferred embodiment, panels 21 are quickly and easily removable so that the unit may be coupled to another unit by another connector 16. Alternatively, panels may be coupled to frame 20 by any of a variety of techniques (e.g., fasteners, welding, hooks, etc.). A removable panel 25 is positioned on and supported by horizontal frame members 24 to provide a removable under-shelf.

[0024] Unit 12 further includes a top 26, a panel 28, a tray slide or shelf 30, and a kick-plate 31. According to an exemplary embodiment, top 26 (e.g., counter top, etc.) is quickly and easily removable from base 18 (e.g., to provide access to base 18, replace, clean, reconfigure, move, modular functionality, etc.). According to a preferred embodiment, top 26 is set on top of base 18 and supported by frame 20. Top 26 is secured or retained in place by down-turned edges on top 26 extending around the upper portion of base 18 combined with the weight of top 26 to inhibit movement except for intended movement. To remove, replace, clean, reconfigure, etc. top 26, one or more persons lifts top 26 from base 18 without having to remove or disconnect fasteners or the like. Panel 28 covers an opening and is removable to provide space/access to controls if unit 12 is to be converted to a hot food unit. Shelf 30 is movable on hinges and include members connected to shelf 30 by hinges and that slide into engagement with receptacles on base to also provide quick and easy removal from base 18. Kick plates 31 are coupled to base 18.

[0025] Unit 14 further includes receptacles 32, controls 34, a shield 36, a tray slide or shelf 38, and a kick-plate 31. Receptacles 32 are configured to receive food pans or the like. Receptacles 32 may be filled with water to heat the food pans (e.g., with steam) or ice to cool the food pans. Controls 34 are for controlling the temperature of receptacles 32 or other operation of unit 14. Shield 36 is coupled to top 26 and is configured to provide a barrier between people and food located in receptacles 32.

[0026] Referring to FIGS. 4-6 and 8, connector 16 (e.g., link, coupler, etc.) couples unit 12 to unit 14 in a secure and tight connection that minimizes or eliminates any space or gap between unit 12 (e.g., base 18 and/or top 26, etc. of unit 12) and unit 14 (e.g., base 18 and/or top 26, etc. of unit 14). Connector 16 includes an upper track 40, a lower track 42, a rear support member 44, a front support member 46, and a face plate 48. The secure and tight connection of unit 12 and unit 14 is provided by an engagement of upper track 40 with adjacent projections 58 and with lower track 42 adjacent projections 72 extending from base 18 of unit 12 and base 18 of unit 14.

[0027] Referring to FIGS. 4, 7, and 10, upper track 40 includes a horizontal base member 50, a pair of spaced apart vertical members 52 extending upwardly from base member 50, and a pair of spaced apart, inwardly disposed, opposed (opposing, opposite, etc.) horizontal engagement members 54 extending from spaced apart vertical members 52. Members 50, 52, 54 may be a panel, plate, portion, flange, or the like. A first (back, rearward, etc.) end of upper track 40 is coupled to an upper end of rear support member 44, and a second (front, forward, etc.) end is coupled to an upper end of front support member 46. Engagement members 54 define a slot 56 (e.g., gap, opening, space, etc.) that is configured to receive a projection 58 extending from an upper portion of frame 20 on unit 12 and an adjacent

projection 58 extending from an upper portion of frame 20 on unit 14. Along a substantial length of slot 56, the spacing between an inner edge of engagement members 54 is generally constant. According to a preferred embodiment, the spacing between engagement members 54 (i.e., width of slot 56) is between about 1/8 inches and about 1/20 inches. According to a particularly preferred embodiment, the spacing is about 1/4 inches. The spacing of slot 56 and the distance between projections 58 is designed to eliminate or minimize any gap between tops 26 of units 12, 14 by pulling projections 58 into a closely adjacent position (e.g., squeezing, compressing, pinching, etc.). At the second end of upper track 40, slot 56 widens to form an engagement guide 62 (e.g., funnel, catch, etc.) that is intended to facilitate and/or guide the engagement (e.g., coupling, connecting, receiving, etc.) with projection 58 on units 12, 14. According to an exemplary embodiment, engagement guide 62 is provided by edges of engagement members 54 provided by an angled cut-out that forms a triangular or "V" shaped portion of slot 56. According to a preferred embodiment showing FIGS. 7 and 10, edges 63 of engagement guide 62 extends at an angle a between about 10 degrees and about 45 degrees relative to slot 56. According to a particularly preferred embodiment, edges of engagement guide 62 extends at an angle a at about 30 degrees relative to slot 56. According to alternative embodiments, the engagement guide may extend at any of a variety of angles relative to the slot. Alternatively, the engagement guide may be provided by any of a variety of shaped openings (e.g., curved, other angles, etc.). According to an exemplary embodiment, projections 58 are generally downwardly extending vertical members of a U-shaped channel where the other spaced apart vertical member is coupled to upper portions (e.g., horizontal members 24) of frame 20 of unit 12 and of frame 20 of unit 14. Alternatively, projections 58 may be angled for the desired alignment and engagement.

[0028] Referring to FIGS. 4, 8, and 11, lower track 42 includes a horizontal base member 64, a pair of spaced apart vertical members 66 extending downwardly from base member 64, and a pair of spaced apart, inwardly disposed, opposed horizontal engagement members 68 extending from spaced apart vertical members 66. A first (back) end of lower track 42 is coupled to a lower end of rear support member 44, and a second (front) end is coupled to a lower end of front support member 46. Engagement members 68 define a slot 70 that is configured to receive projections 72 extending from a lower portion of frames 20 of units 12, 14. Along a substantial length of slot 70, the spacing between engagement members 68 is generally constant. According to a preferred embodiment, the spacing between engagement members 68 is configured and designed comparable to spacing of slot 56, and is designed to eliminate or minimize any gap between tops 26 and the bottom portion of units 12, 14 by pulling projections 72 into a closely adjacent position. At the second end of lower track 42, slot 70 widens to form an engagement guide 74 that is intended to facilitate and/or guide the engagement with lower projection 72 on units 12, 14. According to a preferred embodiment, engagement guide 74 is provided comparable to engagement guide 62 as described for upper track 40 (e.g., triangular or "V" shaped portion of slot 70). According to an exemplary embodiment, projections 72 are generally upwardly extending vertical

members of a U-shaped channel where the other spaced apart vertical member is coupled to frame 20 of unit 12 and frame 20 of unit 14.

[0029] According to a preferred embodiment, projections 58 and 72 are located at both ends of units 12, 14 allowing as many units to be coupled together as needed or desired.

[0030] As such, the projections 58, 72 at the outer ends of system 10 (or both ends of a single unit) receive panels 21. Projections 58, 72 therefore are used to both engage connector 16 when coupling a pair of units 12, 14, and to receive panels 21 to close off ends of system 10. Panels 21 are quickly and easily removable for reconfiguration of system 10 (e.g., coupling another unit).

[0031] Referring to FIGS. 4-6, rear support member 44 and front support member 46 each includes a base member 86 and a pair of spaced apart side members 87 extending from ends of base member 86. According to a preferred embodiment, support members 44, 46 are formed by a stamp and bending operation to form U-shaped channels. According to alternative embodiments, the front and rear support members may have any of a variety of shapes or configurations that provide the desirable structural support.

[0032] According to an exemplary embodiment shown in FIGS. 3 and 4, an opening 88 is provided in connector 16 to allow utilities (e.g., electrical wiring, plumbing, etc.) to pass between unit 12 and unit 14. Opening 88 may be provided by a hole or aperture in a panel that is disposed between upper track 40, lower track 42, rear support member 44, and front support member 46. (The panel may also be provided without apertures to inhibit access between the units.) According to a preferred embodiment, connector 16 does not include such a panel and opening 88 is defined by inner surfaces of base members 86 of upper track 40, base members 86 of rear support member 44, and base members 86 of front support member 46. Opening 88 may also be provided with a support member to provide additional strength and rigidity (particularly when being inserted or removed) as shown in FIGS. 14 and 15 and further discussed below.

[0033] Referring to FIGS. 4-6 and 10, face plate 48 (e.g., front plate, panel, etc.) is intended to provide functional purpose and a decorative or ornamental purpose. As for the functional purpose face plate 48 is configured to limit the travel/movement of connector 16 so that connector 16 is in a last and predetermined position when engaged. Face plate 48 is also configured to engage frames 20 of units 12, 14 by at least partially wrapping around vertical members 22. Face plate 48 includes a base panel 90, flanges 92, and flanges 94. Flanges 92, 94 extend generally perpendicular to base panel 90. Face plate 48 is further configured to provide a user interface (e.g., handle, grip, etc.) for the user to grasp connector 16. As for the ornamental purpose, face plate 48 is configured to provide a continuous surface as visible to a person viewing system 10 both along the outside surface of system 10 and on an inside surfaces of frames 20 (e.g., by flanges 92, 94 wrapping around vertical members 22).

[0034] Referring to FIGS. 1-3, 7, 9, and 10, to assemble system 10, unit 12 is positioned (located, disposed, etc.) next to (proximate) unit 14 so that upper projection 58 and lower projection 72 on unit 12 are adjacent to upper projection 58 and lower projection 72 on unit 14. Connector 16 is then positioned so that upper and lower projections 58, 72 are aligned (registered) with engagement guides 62, 74 and slots 56, 70. Connector 16 is then moved in to bases 18 of units

12, 14 so that projections **58, 72** slide through engagement guides **62, 74** and into slots **56, 70**. If projections **58, 72**, are slightly separated or are not sufficiently closely aligned, engagement guides **62, 74** will move/guide projections into proper or better position and alignment (i.e., together towards a closely adjacent position as connector **16** is slid into units **12, 14**). Connector **16** is further moved into engagement as projections **58, 72** slide through slots **56, 70** and until face plate **48** abuts vertical members **22** and is generally in planar alignment with the front surfaces of bases **18** of units **12, 14**.

[0035] To disassembly system **10**, a person grasps front plate **48** and pulls connector **16** out from bases **18** of units **12, 14**.

[0036] FIGS. **12** and **13** are alternative embodiments for the engagement of connector **16** with upper track **40** and lower track **42**. A friction reduction member is provided to reduce the friction between projections **56, 72** and interior edges of engagement members **54, 68** (which define slots **56, 70**, respectively). Reducing the friction is intended to reduce the effort need to insert or remove the connector.

[0037] Referring to FIG. **12**, a friction reduction member **100** is shown as an “L”-shaped member. According to an exemplary embodiment, member **100** is coupled (e.g., bonded or joined by adhesive, tape, fastener, etc.) to the U-shaped channels that provide projections **56, 72**. Alternatively, member **100** may be in the form of strip of flexible material bonded to the “U”-shaped channel (e.g., tape with an adhesive such as a pressure sensitive adhesive). The tape may be applied to the “U”-shaped channel before or after it is shaped (stamped, bent, etc.) into the desired configuration (shown as a “U” shape). The friction reduction member may be made from any of a variety of materials that provide friction reduction properties. For example, an extruded or molded polymer such as an acetal resin (e.g., Dupont Delrin), a thermoset (e.g., Bakelite), nylon, a rubber (e.g., Sani-Tuff), or any of a variety of thermoplastics or thermosets. The member **100** may be treated to have low friction properties (e.g., TEFLON or other low friction treatments applied to a tape or other base).

[0038] Referring to FIG. **13**, a friction reduction member **102** is shown according to an alternative embodiment. Member **102** is coupled to engagement members **54, 68**. Member **102** may be a flexible sheet or member that is wrapped and adhered or bonded to interior edges of engagement members **54, 68** (e.g., a tape with an adhesive). Alternatively, members are extrusions (e.g., “U”-shaped) that are slid onto engagement members **54, 68** and held in place by an adhesive, tape, fastener, pressure (e.g., an interference fit between channel and width of engagement members **54, 68**), or the like. Member **102** may be coupled before or after the upper and lower tracks are formed.

[0039] FIGS. **14** and **15** show alternative embodiments for connector **16** that are configured to provide additional strength and rigidity to connector **16**, particularly when being inserted (installed) or removed (uninstalled). Referring to FIG. **14**, connector **16** further includes a horizontal support member **110**. Support member **110** extends between rear support member **44** and front support member **46**. As shown, support member **110** is located approximately midway between upper track **40** and lower track **42**. According to alternative embodiments, support member **110** may be at any of a variety of locations that provide desirable amount of structural support to connector **16**. Support member **110**

may be a formed channel (e.g., U-shaped, L-shaped, etc.), panel, plate, rod, tube, or the like.

[0040] Referring to FIG. **15**, connector **16** further includes a vertical support member **112**. Support member **112** extends between rear support member **44** and front support member **46**. As shown, support member **112** is located approximately midway between rear support member **44** and front support member **46**. According to alternative embodiments, support member **112** may be at any of a variety of locations that provide desirable amount of structural support to connector **16**. Support member **112** may be a formed channel (e.g., U-shaped, L-shaped, etc.), panel, plate, rod, tube, or the like.

[0041] According to a preferred embodiment, top, panels, frame and connector are made of stainless steel. According to a particular preferred embodiment, the upper track, lower track, rear support member, and front support member are formed by a stamping and bending operation from a single sheet of metal. Alternatively, the connector and other components may be made from other metals or from polymers.

[0042] Before proceeding to the claims, several comments can be made about the general applicability and the scope thereof. First, while the components of the disclosed embodiments will be illustrated as a modular sectional system designed for food service, the features of the disclosed embodiments have a much wider applicability. For example, the link or coupling member design is adaptable for other displays and storage, and other office, home, industrial, medical, or educational applications which employ a modular design. Further, the size of the various components and the size of the sectionals and link can be widely varied.

[0043] Second, it is important to note that the term “sectional,” “connector,” and “track” are intended to be broad terms and not terms of limitation. These components may be used with any of a variety of products or arrangements and are not intended to be limited to use with modular display applications. For purposes of this disclosure, the term “coupled” shall mean the joining of two members directly or indirectly to one another. Such joining may be stationary in nature or movable in nature. Such joining may be achieved with the two members or the two members and any additional intermediate members being integrally formed as a single unitary body with one another or with the two members or the two members and any additional intermediate member being attached to one another. Such joining may be permanent in nature or alternatively may be removable or releasable in nature. Such joining may also relate to mechanical, fluid, or electrical relationship between the two components.

[0044] It is also important to note that the construction and arrangement of the elements of the link and modular system as shown in the preferred and other exemplary embodiments are illustrative only. Although only a few embodiments of the present invention have been described in detail in this disclosure, those skilled in the art who review this disclosure will readily appreciate that many modifications are possible (e.g., variations in sizes, dimensions, structures, shapes and proportions of the various elements, values of parameters, mounting arrangements, materials, colors, orientations, etc.) without materially departing from the novel teachings and advantages of the subject matter recited in the claims. Accordingly, all such modifications are intended to be included within the scope of the present invention as defined in the appended claims. The order or sequence of any

process or method steps may be varied or re-sequenced according to alternative embodiments. In the claims, any means-plus-function clause is intended to cover the structures described herein as performing the recited function and not only structural equivalents but also equivalent structures. Other substitutions, modifications, changes and/or omissions may be made in the design, operating conditions and arrangement of the preferred and other exemplary embodiments without departing from the spirit of the present invention as expressed in the appended claims.

What is claimed is:

1. A modular food service system comprising:
 - a first food service unit having a first upper projection and a first lower projection;
 - a second food service unit having a second upper projection and a second lower projection;
 - a connector for coupling the first food service unit to the second food service unit, the apparatus comprising:
 - an upper track having a slot and an engagement guide configured to receive and guide the first upper projection and the second upper projection into a sliding engagement with the slot;
 - a lower track having a slot and an engagement guide configured to receive and guide the first lower projection and the second lower projection into a sliding engagement with the slot;

wherein the first food service unit is coupled to the second food service unit by the upper track engaging the first upper projection and the second upper projection, and by the lower track engaging the first lower projection and the second lower projection.
2. The modular food system of claim 1 wherein the engagement guide comprises a first edge and a second edge, the first edge and the second edge are angled relative to the slot to increase the width of the opening that receives the first projection and the second projection.
3. The modular food system of claim 2 wherein the first edge extends between about a 10 degree and about a 45 degree angle relative to the slot, and the second edge extends between about a 10 degree and about a 45 degree angle relative to the slot.
4. The modular food system of claim 3 wherein the first edge extends about 30 degrees relative to the slot, and the second edge extends about 30 degrees relative to the slot.
5. The modular food system of claim 1 further comprising one or more friction reduction members configured to reduce friction between the first food service unit, connector, and the second food service unit.
6. The modular food system of claim 5 wherein the one or more friction reduction members comprises a polymer component coupled to one of the upper track, lower track, first upper projection, first lower projection, second upper projection, or second lower projection.
7. The modular food system of claim 6 wherein the one or more friction reduction members comprises a polymer extrusion.
8. The modular food system of claim 7 wherein the polymer extrusion is "L" shaped or "U" shaped.
9. The modular food system of claim 5 wherein the one or more friction reduction members comprises a flexible member.
10. The modular food system of claim 9 wherein the flexible member is a Teflon coated tape.

11. The modular food system of claim 5 wherein the one or more friction reduction members comprises Saniboard, Delrin, or Bakelite.

12. The modular food service system of claim 1 wherein the upper track comprises a pair of spaced apart vertical members, and a pair of spaced apart horizontal engagement members that define a slot that receives the first upper projection and the second upper projection, and wherein the lower track comprises a pair of spaced apart vertical members, and a pair of spaced apart horizontal engagement members that define a slot that receives the first lower projection and the second lower projection.

13. The modular food service system of claim 12 wherein the first food service unit comprises a base, the first upper projection extends downwardly from an upper portion of the base, and the first lower projection extends upwardly from a lower portion of the base.

14. The modular food service system of claim 1 wherein the connector is quickly and easily removable from engagement with the first food service unit and the second food service unit.

15. The modular food service system of claim 1 wherein the first food service unit comprises a third upper projection and a third lower projection configured to receive a second connect to couple the first food service unit to a third food service unit or to receive a panel.

16. A connector for coupling a first modular unit to a second modular unit, the first modular unit having a first upper projection and a first lower projection and the second modular unit having a second upper projection and a second lower projection, the connector comprising:

- a front member;
- a rear member;
- an upper track extending between upper portions of the front member and the rear member, the upper track having a slot and an engagement guide configured to receive and guide the first upper projection and the second upper projection into a sliding engagement with the slot;
- a lower track extending between lower portions of the front member and the rear member, the lower track having a slot and an engagement guide configured to receive and guide the first lower projection and the second lower projection into a sliding engagement with the slot;

wherein the first modular unit is coupled to the second modular unit by the upper track engaging the first upper projection and the second upper projection, and the lower track engaging the first lower projection engaging the second lower projection.

17. The connector of claim 16 wherein the upper track comprises a base, a pair of spaced apart vertical members extending from the base member, and a pair of spaced apart horizontal members extending from the vertical members to form a slot therebetween, and wherein the lower track comprises a base member, a pair of spaced apart vertical members extending from the base member, and a pair of spaced apart horizontal members extending from the vertical members to form a slot therebetween.

18. The connector of claim 16 wherein the engagement guide comprises a first edge and a second edge on the pair of spaced apart horizontal members, the first edge and the

second edge angled relative to the slot to increase the width of the opening of the slot that receives the first projection and the second projection.

19. The connector of claim 18 wherein the first edge extends between about a 10 degree and about a 45 degree angle relative to the slot, and the second edge extends between about a 10 degree and about a 45 degree angle relative to the slot.

20. The connector of claim 19 wherein the first edge extends about 30 degrees relative to the slot, and the second edge extends about 30 degrees relative to the slot.

21. The connector of claim 16 further comprising one or more friction reduction members configured to reduce friction between the first food service unit, connector, and the second food service unit.

22. The connector of claim 21 wherein the one or more friction reduction members comprises a polymer component coupled to one of the upper track, lower track, first upper projection, first lower projection, second upper projection, or second lower projection.

23. The connector of claim 16 further comprising a support member coupled to the upper track and to the lower track and located between the front member and the rear member.

24. The connector of claim 16 further comprising a support member coupled to the front member and to the rear member and located between the upper track and the lower track.

25. The connector of claim 24 wherein the front member comprises a U-shaped channel, and wherein the rear member comprises a U-shaped channel.

26. The connector of claim 25 wherein the upper track, the lower track, the front member, and the rear member define an interior space void of additional structure.

27. The connector of claim 16 wherein the apparatus comprises a front panel having a pair of opposed flange members extending along at least a portion of the panel approximately perpendicular to the panel.

28. The connector of claim 27 wherein a pair of opposing tabs extending from the panel substantially parallel to the panel.

29. The connector of claim 16 wherein the first upper projection is a generally vertical member of a U-shaped channel coupled to the first modular unit, the second upper projection is a generally vertical member of a U-shaped channel coupled to the second modular unit, the first lower projection is a generally vertical member of a U-shaped channel coupled to the first modular unit, and the second lower projection is a generally vertical member of a U-shaped channel coupled to the second modular unit.

30. A method for configuring, reconfiguring, or installing a modular system, the method comprising:

providing a first modular unit and a second modular unit, the first modular unit having a first upper projection and a first lower projection, and the second modular unit having a second upper projection and a second lower projection;

providing a connector having an upper track and a lower track, the upper track having an upper slot and an upper engagement guide, the lower track having a lower slot and a lower engagement guide;

positioning the first modular unit proximate the second modular unit so that the first upper projection is proximate

the second upper projection and the first lower projection is proximate the second lower projection;

aligning the engagement guide and the slot of the upper track with the first upper projection and the second upper projection;

aligning the engagement guide and the slot of the lower track with the first lower projection and the second lower projection;

coupling the first modular unit to the second modular by moving the connector so that the upper engagement guide guides the first upper projection and the second upper projection into engagement with the upper track and slides into the upper slot and the lower engagement guide guides the first lower projection and the second lower projection into engagement with the lower track and slides into the lower slot.

31. The method of claim 30 wherein the upper engagement guide directs the first upper projection and the second upper projection into the upper slot on the upper track.

32. The method of claim 30 wherein moving the connector constricts the first upper projection and the second upper projection, and constricts the first lower projection and the second lower projection to position the first food service unit closely adjacent to the second food service unit.

33. The method of claim 30 wherein moving the connector pulls the first modular unit closer to the second modular unit.

34. The method of claim 30 further comprising moving the connector out from engagement with the first modular unit and the second modular unit.

35. In a modular food service system comprising a first food service unit having a first upper projection and a first lower projection; a second food service unit having a second upper projection and a second lower projection; a connector for coupling the first food service unit to the second food service unit, the connector comprising an upper track having a slot configured to receive the first upper projection and the second upper projection into a sliding engagement with the slot, and a lower track having a slot configured to receive the first lower projection and the second lower projection into a sliding engagement with the slot; wherein the first food service unit is coupled to the second food service unit by the upper track engaging the first upper projection and the second upper projection, and by the lower track engaging the first lower projection engaging the second lower projection, the improvement comprising:

one or more friction reduction members configured to reduce friction between the first food service unit, connector, and the second food service unit.

36. The modular food system of claim 35 wherein the first food service unit comprises a first upper projection and a first lower projection; the second food service unit comprises a second upper projection and a second lower projection; the connector comprises an upper track having a slot configured to receive the first upper projection and the second upper projection into a sliding engagement with the slot, and a lower track having a slot configured to receive the first lower projection and the second lower projection into a sliding engagement with the slot; wherein the first food service unit is coupled to the second food service unit by the upper track engaging the first upper projection and the second upper projection, and by the lower track engaging the first lower projection engaging the second lower projection.

37. The modular food system of claim **36** wherein the one or more friction reduction members comprises a polymer component coupled to one of the upper track, lower track, first upper projection, first lower projection, second upper projection, or second lower projection.

38. The modular food system of claim **37** wherein the one or more friction reduction members comprises a polymer extrusion.

39. The modular food system of claim **38** wherein the polymer extrusion is “L” shaped or “U” shaped.

40. The modular food system of claim **35** wherein the one or more friction reduction members comprises a flexible member.

41. The modular food system of claim **39** wherein the flexible member is a Teflon coated tape.

42. The modular food system of claim **36** further comprising a support member coupled to the upper track and to the lower track and located between the front member and the rear member.

43. The modular food system of claim **36** further comprising a support member coupled to the front member and to the rear member and located between the upper track and the lower track.

* * * * *