

(12) STANDARD PATENT
(19) AUSTRALIAN PATENT OFFICE

(11) Application No. **AU 2002224659 B2**

(54) Title
Exercise device

(51) International Patent Classification(s)
A63B 21/00 (2006.01) **A63B 21/02** (2006.01)

(21) Application No: **2002224659** (22) Date of Filing: **2002.01.18**

(87) WIPO No: **WO02/056971**

(30) Priority Data

(31) Number	(32) Date	(33) Country
PR 2618	2001.01.18	AU

(43) Publication Date: **2002.07.30**

(43) Publication Journal Date: **2003.02.13**

(44) Accepted Journal Date: **2006.02.02**

(71) Applicant(s)
Terrence Tremayne

(72) Inventor(s)
Tremayne, Terrence, Colin

(74) Agent / Attorney
Freehills Patent & Trade Mark Attorneys, Level 43 101 Collins Street, Melbourne, VIC, 3000

(56) Related Art
US 5090694
US 5002271
US 5324243
US 5080353
US 5110121
US 5116359
US 6056675
WO 1984/004690
US 5044633
DE 20000466

(12) INTERNATIONAL APPLICATION PUBLISHED UNDER THE PATENT COOPERATION TREATY (PCT)

(19) World Intellectual Property Organization
International Bureau



(43) International Publication Date
25 July 2002 (25.07.2002)

PCT

(10) International Publication Number
WO 02/056971 A1

(51) International Patent Classification⁷: A63B 21/00, 21/02

(21) International Application Number: PCT/AU02/00053

(22) International Filing Date: 18 January 2002 (18.01.2002)

(25) Filing Language: English

(26) Publication Language: English

(30) Priority Data:
PR 2618 18 January 2001 (18.01.2001) AU

(71) Applicant and

(72) Inventor: TREMAYNE, Terrence, Colin [AU/AU]; 46 Alma Road, St Kilda, Victoria 3182 (AU).

(74) Agent: FREEHILLS CARTER SMITH BEADLE; 101 Collins Street, Melbourne, Victoria 3000 (AU).

(81) Designated States (national): AE, AG, AL, AM, AT, AU, AZ, BA, BB, BG, BR, BY, BZ, CA, CH, CN, CO, CR, CU,

CZ, DE, DK, DM, DZ, EC, EE, ES, FI, GB, GD, GE, GH, GM, HR, HU, ID, IL, IN, IS, JP, KE, KG, KP, KR, KZ, LC, LK, LR, LS, LT, LU, LV, MA, MD, MG, MK, MN, MW, MX, MZ, NO, NZ, OM, PH, PL, PT, RO, RU, SD, SE, SG, SI, SK, SL, TJ, TM, TN, TR, TT, TZ, UA, UG, US, UZ, VN, YU, ZA, ZM, ZW.

(84) Designated States (regional): ARIPO patent (GH, GM, KE, LS, MW, MZ, SD, SL, SZ, TZ, UG, ZM, ZW), Eurasian patent (AM, AZ, BY, KG, KZ, MD, RU, TJ, TM), European patent (AT, BE, CH, CY, DE, DK, ES, FI, FR, GB, GR, IE, IT, LU, MC, NL, PT, SE, TR), OAPI patent (BF, BJ, CF, CG, CI, CM, GA, GN, GQ, GW, ML, MR, NE, SN, TD, TG).

Published:

— with international search report

For two-letter codes and other abbreviations, refer to the "Guidance Notes on Codes and Abbreviations" appearing at the beginning of each regular issue of the PCT Gazette.

(54) Title: EXERCISE DEVICE

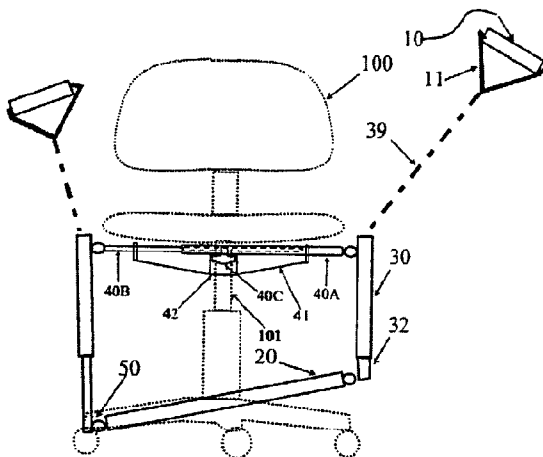

(57) Abstract: This invention relates to an exercise device which includes means 40, 41, 42, 43 for mounting the device to a chair 100, variable resistance means 30 attached to the mounting means 40, 41, 42, 43, a handle 10 attached to a first end of the resistance means 30 and a second operating means 20 attached to the opposite end of the resistance means 30. Movement of the handle 10, second operating means 20 or both enable exercise against the resistance means 30. Preferably the resistance means 30 includes a resilient means, in the form of an elastic cord 39 or spring, located inside a housing.



WO 02/056971 A1

EXERCISE DEVICE

Background of Invention

This invention relates to improvements in exercise devices capable of being attached to or integrated with a chair and relates, in one form, to an improved design that is easily detachable and compact enough to be portable.

Prior Art

Many of the inventions that adapt a chair to an exercise machine claim to exercise all muscle groups, but to do so they require the engineering of a completely new chair capable of housing a variety of cables, pulleys, resistance mechanisms and weights inside the chair which makes them complicated and expensive to manufacture. Inventions that attach to a chair are often aesthetically ugly, cumbersome to adjust to different exercises and can realistically only exercise a limited number of muscle groups.

Recent research of work related injuries shows that back, neck, wrist and other injuries caused by long periods of sitting, or doing desk work account for over 50% of work days lost and apart from causing discomfort to the injured it is a significant cost to employers. These injuries can be reduced, or eliminated by doing simple "chair exercises" which include stretching, pushing, or pulling against a chair or another fixed piece of furniture every hour or so during the day.

It is also known that resistance exercising (pulling a simple resistance cord with a handle at each end and holding for say a count of 5) is up to 40% more effective than free weight exercising or peddling a bicycle. Approximately 10 minutes of reasonably energetic (not strenuous) exercise per day is sufficient to maintain reasonable health and fitness for the average person and that exercise done during the day is cumulative in effect, i.e. five short exercise sessions of 2 minutes, or ten sessions of just 1 minute is almost as effective as a single 10 minute exercise session. Furthermore, with over 30% of the workforce and all school children spending most of their time in a chair, there is ample opportunity for engaging in "chair exercises".

It is therefore desirable to provide an improved exercise device which, at least in part, alleviates some of the shortcomings of current exercise devices.

Summary of Invention

In accordance with one aspect of the invention there is provided an exercise device for mounting to a chair, the device including a first resistance means that includes a resilient means having a length and which resilient means is linked to first and second operating means at respective opposite ends of the resilient means whereby movement of the first and/or second operating means enables exercise against said resilient means and wherein an intermediate portion of said length is looped around a plurality of spaced pulleys such that said first and second operating means are spaced by a distance less than said length when said resilient means is at rest, and are operable, during exercise, to be spaced by a distance greater than said length.

In one particular embodiment of the first aspect, at least one of said plurality of pulleys is associated with the second operating means for movement therewith such that the resistance experienced by movement of the second operating means is greater than the resistance experienced by movement of the first operating means. A further embodiment of the first aspect provides that the respective opposite ends of the resilient means are linked to the first operating means and an abutment. Preferably, the first aspect of the invention includes removable chair mounting means enabling removable mounting of the exercise device to a chair for portability.

A second aspect of the invention provides an exercise device for mounting to a chair, the device including:

a resistance means that includes a resilient means having a length and which resilient means is linked to first and second operating means at respective opposite ends of the resilient means whereby movement of the first and/or second operating means enables exercise against said resilient means; and

means for removable mounting of the device to a chair such that the device is portable.

The invention provides in a third aspect an exercise device for mounting to a chair, the device including:

a resistance means that includes a resilient means having a length and which resilient means is linked to first and second operating means at respective opposite ends of the resilient means whereby movement of the first and/or second operating means enables exercise against said resilient means; and

means for mounting the device to a chair such that the first and second operating means are displaceable between a first operating position and a second position for storage when the device is mounted to the chair and not being used.

The exercise device of each aspect preferably includes a further resistance means located inside a housing to provide bias against extension of the resistance means.

According to each aspect, the first operating means preferably is a handle and the resilient means is an elastic cord or spring.

In this embodiment the resistance experienced through extension of the cord means by movement of the second operating means is four times greater than that experienced through movement of the handle. This is due to movement of the second operating means requiring extension of four sections of the cord means as opposed to one section when the handle is used. However, when the hook is attached to the handle, the resistance through the handle doubles as a user must extend two sections of the cord means while the resistance through the second operation means remains as it previously was. In this arrangement, the resistance through the second operating means is merely double that experienced through the handle.

3a

The second operating means of each resistance means may include a stirrup adapted for use with a user's foot. In a preferred embodiment the second operating means is a common operating means connecting the opposite end of each resistance means whereby movement of the common operating means is against both resistance means. The common operating means may include a bar, rod or tube.

In a further embodiment the common operating means is an extendable footrest with two separate foot-receiving means adapted for relatively slidable movement whereby the two foot-receiving means are biased together by further resistance means such that movement of the two foot-receiving means enables exercise against the further resistance means. Preferably, the slidable movement of the two foot-receiving means is coaxial with a support bar joining the two foot-receiving means.

In preference, the resistance means includes a housing comprising at least one component, but preferably comprising at least two components that co-operate to telescopically accommodate extension of the resistance means. The uppermost and lowermost components of the housing of each resistance means are pivotally attached respectively to an extension bar and the common operating

means by universal joints. The universal joints preferably comprise a ball and socket joint, but may alternatively be linked rings, a flexible polymeric connection, or a pair of connections rotatable about mutually orthogonal axes.

It is also preferable that the portable exercise device is adapted to be
5 removably mounted on a standard office chair. The removable mounting means preferably further includes a central mounting device and one or more arms extending from the central mounting means and wherein the or each arm is attached to the or each variable resistance means or via an extension bar supported by the or each arm. In a preferred embodiment, the central mounting
10 means comprises a clamp in the form of a generally cylindrical tube and wherein the or each arm is pivotable about an axis coaxial with an axis of the cylindrical clamp. It is further preferable that the or each arm is pivotable between first operating positions and a second position where the or each variable resistance means is substantially flush with a chair for out-of-the-way storage.

15 In one particular embodiment, the handle includes a channel in which an abutment, attached to the end of the resistance means is slidable. The handle has an aperture which permits the ingress and egress of the abutment from the channel.

A preferred embodiment of the present invention will now be described, by
20 way of example only, with reference to the accompanying drawings, in which:

Figure 1 is a front perspective view of a portable exercise device, in accordance with the invention, attached to a standard office chair.

Figure 2 is a side view of the exercise device.

25 Figures 3 and 4 are front perspectives of the freedom of movement available in the exercise device.

Figure 5 is a side perspective of the range of movement available in the exercise device.

Figure 6 is a side view schematic of a resistance means with a three component housing.

Figure 7 is a schematic front view of the resistance means depicted in Figure 6.

5 Figure 8 shows the arrangement of the elastic cord in a resistance means comprising three pulley wheels.

Figure 9 is a schematic of a three component housing.

Figure 10 is a top perspective of the exercise device (footrest not shown) attached to a standard office chair.

10 Figure 11 is a perspective view of the chair attachment frame and clamp.

Figure 12 is a top perspective of a chair attachment means comprising straps.

15 Figure 13 is a top perspective of an alternative chair attachment means with two swing arms and showing freedom of movement available in the exercise device.

Figure 14 is a top view of the chair attachment means in Figure 13 in a storage position.

Figure 15 is a perspective of a swing arm of the chair attachment means in Figure 13.

20 Figure 16 is a front schematic of alternative second operating means including an expanding resistance means shown in the rest position.

Figure 17 is a top schematic of the alternative second operating means of Figure 13 shown in the expanded position.

Figure 18 is a top view schematic of an alternative means for mounting the resistance means to the chair attachment means.

Figure 19 is front schematic view of the alternative mounting means in Figure 18 without the pulleys and elastic cord.

5 Figure 20 is perspective schematic of the mounting means in Figure 18 in a locked position.

Figure 21 is perspective schematic the mounting means in Figure 18 in an unlocked position.

10 Figure 22 is a top view schematic of a further alternative chair attachment means, with a primary arm in a retracted position.

Figure 23 is a top view schematic of the chair attachment means Figure 22 with the primary arm extended fully.

Figure 24 is a schematic side view of a further handle embodiment in a storage position on top of the housing for the resistance means.

15 Figure 25 is a schematic end view of the handle in Figure 24.

Figure 26 is a schematic side view of the handle in Figure 24 in the operating position on top of the housing.

Figure 27 is a perspective schematic of the handle in Figure 26 in the operating position.

20 Figure 28 is a side view of a portable exercise device with the handle in Figure 24 in the storage position.

Figure 29 illustrates movement of the device in Figure 28 to a storage position.

Description of the preferred embodiments

The portable exercise device shown in Figures 1 and 2 comprises a chair attachment means 40, 41, 42, 43, resistance means 30, a second operating means in the form of a common operating means 20, handles 10 at the end of
5 each resistance means and universal joints 50 connecting the operating means 20 to the resistance means 30 and the resistance means 30 to the chair attachment means 40, 41, 42, 43.

The chair attachment means 40, 41, 42, 43 enables the device to be removed from a chair and re-attached to other chairs, thereby providing the device
10 with portability. However, it is clear that the device may be adapted to be mounted permanently or integrated into a chair by a suitable fixing means, eg. bolts, welding or bonding adhesive. For instance, the chair attachment means 40, 41, 42, 43 may be omitted in favour of the universal joints 50 being mounted directly on the chair.

As depicted in Figures 6 and 7, the resistance means 30 preferably
15 comprises a rubberised elastic cord 39 maintained within a housing 35 made up of three components 31, 32, 34 which together operate telescopically. The elastic cord may be substituted with appropriate alternatives, such as a coil spring or elastic straps. The elastic cord 39 is attached to handle 10 at one end and
20 terminates at its opposite end at a fixture in the uppermost component 34 of the resistance means 30. The resistance means 30 is described in greater detail at a later stage. In this manner, and with the universal joints 50 connecting the common operating means 20, resistance means 30 and chair attachment means 40, 41, 42, 43, the common operating means 20 and handles 10 may be extended
25 by any movement lateral, longitudinal or combination thereof by the user's arms or legs in relation to the direction in which the user is facing, as shown in Figures 3, 4 and 5.

The chair attachments means 40, 41, 42, 43, shown in Figures 10 and 11, comprises a clamp 42 which is fixed to the centre post of a standard office chair

101, two divergent struts 41 and an extension bar 40 which can be adjusted in length to accommodate chairs of different widths.

The clamp 42 is composed of two opposed semi-circular portions 42, which when placed opposite one another substantially form a cylindrical tube. The
5 semi-circular portions 42 have a lug on each end and each lug has two holes through which bolts 43 may be passed to releasably secure the semi-circular portions 42 together and thereby clamp the exercise device to the chair post 101. Attaching the exercise device to the chair post 101 has the advantage of allowing the exercise device to pivot with the chair so it always remains in the same
10 position relative to the user regardless of chair rotation.

The exercise device can easily be removed from the chair by releasing the bolts and opening the clamp. This allows the exercise device to be transported and placed on any chair by simply fitting the clamp.

Two divergent arms extend from one semi-circular portion 42 of the clamp
15 42, 43. The ends of each arm 41 include cut-out portions which receive therethrough a telescopically extendable bar 40. The bar 40 includes an outer sleeve 40A and an inner sleeve 40B which co-operate to provide the telescopic extension. The outer sleeve 40A has a rectangular tubular cross-section and a hole passing through its top and bottom surfaces at a position near the end which
20 receives the inner sleeve 40B.

The inner sleeve 40B also has a rectangular cross-section which may be either tubular or solid. The inner sleeve 40B is dimensioned to comfortably fit inside the tubular section of the outer sleeve 40A. An elongated hole 44, cut between the top and bottom sides of the inner sleeve, is located near the end of
25 the inner sleeve 40B which is enclosed by the outer sleeve 40A and extends approximately half the length of the inner sleeve 40B.

A nut 40C is welded or otherwise fixedly secured over the hole in the top surface of the outer sleeve 40A and a threaded bolt 40D is passed through the hole in the bottom surface of the outer sleeve 40A, the elongate hole 44 in the

inner sleeve 40B and the hole in the top surface of the outer sleeve 40A to threadedly engage with the nut 40C. By such engagement the inner and outer sleeves 40A, 40B can be adjusted to a desired length and then retained in that extension by frictional resistance from the bolt 40D being tightened. This means of
5 adjustment allows the exercise device to be adapted to fit chairs of different widths.

An alternative means of adjustment is illustrated in Figures 22 and 23 where the outer sleeve 40A has a series of holes (not shown) disposed laterally across the length of the sleeve 40A and aligned linearly. Each inner sleeve 40B
10 includes a spring clip 49, formed in a U-shape, which is attached to the inside of the inner sleeve 40B at a point marked 63. The opposite arm of the clip 49 has a cylindrical protuberance 59, which is biased by the spring clip 49 to exit through an aperture (not shown) in the inner sleeve 40B and pass through one of the holes in the outer sleeve 40A. In this manner, the inner sleeve 40B is locked with the outer
15 sleeve 40A against sliding movement by the shear resistance of the protuberance 59 in the holes of the outer sleeve 40A. The protuberance 59 is sized to be comfortably moved through the holes in the outer sleeve 40A.

In operation, the distance by which the inner sleeves 40B extend from the outer sleeve 40A is adjusted by a user depressing the protuberance 59 back
20 through the hole in the outer sleeve 40A which it presently occupies, to release inner sleeve 40B from engagement with the outer sleeve 40A. The user may then adjust the length of the inner sleeve 40B to a desired position whereon the user allows the protuberance 59 to spring back through the nearest hole in the outer sleeve 40A thereby locking the inner and outer sleeves 40B, 40A together.

25 In another preferred embodiment shown in Figures 13 to 15 the two arms 41 are hinged at the semi-circular portion of the clamp 42, 43 with a bracket 45 and a nut and bolt 47. At the other end of the arms 41 the universal joints 50 are hinged by a nut and bolt 47 for pivotal movement about the vertical axis of the bolt 47. Figure 13 depicts the range of movement available with the pivotable arms 41.
30 It will be appreciated that the arms 41 allow the resistance means 35 to move in a plane parallel to the ground from a position between the users legs through to the

rear of the office chair. By moving the arms 41 to their rear most position, the second operating means and variable resistance means may be moved to a position flush under the office chair for out-of-the-way storage.

In another preferred embodiment the chair attachment means may
5 comprise a strap 61, as shown in Figure 12, or a series of straps with buckles.

In a further alternative, the extendible bar 40 is mounted to the chair post 101 via a strut 80 and sleeve 81, as in Figures 22 and 23, which permit movement of the bar 40 relative to the post 101. In this embodiment, the bar 40 may be rigidly or pivotally attached to the strut 80 by any appropriate means of attachment.

10 The strut 80 has a rectangular cross-section, however alternatively shaped cross-sections may otherwise be used. A sleeve 81, mounted to the clamp 42, 43, has a cross-section corresponding to the cross-section of the strut 80 and is adapted in terms of size to snugly receive the strut 80 whilst permitting sliding movement of the strut 80 through the sleeve 81. A side of the sleeve 81 includes
15 an aperture (not shown) over which a nut 82 is fixed on the outer surface of the side of the sleeve 81. Alternatively, the aperture may include a thread adapted to engage with a correspondingly threaded bolt 83. A bolt 83 is used to threadedly engage with the nut 82 such that tightening the bolt 83 acts to clamp the strut 80 in the sleeve 81 thereby preventing sliding movement of the strut 80 relative to the
20 sleeve 81. Accordingly, the position of the strut 80 relative to the sleeve 81 is adjustable by releasing the bolt 83, moving the strut 80 and re-tightening the bolt 83.

The strut 80 is preferably divided into first and second portions 85, 84, respectively. The first portion 85 permits adjustment of the position of the bar 40
25 relative to the sleeve 81, as discussed above. The second portion 84 is oblique to the first portion 85 so that the bar 40 is supported in its middle by accounting for the offset of the sleeve 81.

When appropriately adjusted to fit the chair the extension bar 40 should be approximately equal in length to the width of the chair 100. Attached to each end

of the extension bar 40 are universal joints 50. The universal joints 50 preferably comprise ball and socket joints. The socket portion of the joint is mounted in the end of the extension bar 40 and the ball portion includes a bolt 51. The bolt 51 passes through holes on opposing sides near the top of the uppermost component 5 31 of the resistance means 30. The ball and socket joints 50 provide the resistance means 30 with freedom of pivotal movement in all directions whereby this freedom is only limited by the extent to which the bolt 51 interferes with the socket housing around the ball.

While the ball and socket joint is the preferred means of joining extension 10 bar 40 to resistance means 36 for universal movement, other universal joints may be equally applicable. For instance, coupled rings or a flexible polymer.

In one particular embodiment shown in Figures 18 to 23 the resistance means 30 is attached to the chair attachment means 40, 41, 42, 43 via a bush 57 and arm 55 mounted in the outer and inner sleeves 40A and 40B, each being 15 cylindrical tubes in this instance.

Each arm 55 has a flat rectangular plate section 58 with a hole 53 therethrough for receipt of a bolt 51 on which a pulley 33 is mounted to enable rotation of the bolt 51. This enables the resistance means 30 to be attached to the chair attachment means 40, 41, 42, 43 rather than via the housing 35. The arms 20 55 also have a cylindrical section 60 with two lugs 56A, 56B spaced apart at opposite ends of the cylindrical section and radially aligned.

The cylindrical section 60 has a diameter marginally less than the inner diameter of the bush 57 such that the arm 55 can freely rotate about a central longitudinal axis of the cylindrical section 60. The bush 57 is formed as a 25 cylindrical tube with a longitudinal gap along one side. Collectively, the rotation of the arm 55 in the bush 57 and the bolt 51 in the hole 53 provide universal movement of the resistance means relative to the inner and outer sleeves.

As shown in Figure 19, the lugs 56A, 56B have a height above the surface of the cylindrical section 60 less than the width of the tube wall of the bush 57.

Accordingly, the arm 55 may be moved into engagement with the bush 57 by aligning the lugs 56A, 56B with the gap in the bush 57 and inserting the arm 55 until the lug 56A has cleared the bush 57. Rotating the arm 55, until the lugs 56A, 56B are no longer aligned with the gap, locks the arm with the bush 57. The arm
5 55 is removed by following the above process in reverse.

The resistance means depicted in Figures 6 to 9 will now be described. The resistance means 30 comprises a housing 35 preferably consisting of three telescopic components 34, 31, 32 which allows for extension of the resistance means 30 without exposure of the elasticised cord 39 to interference by objects or
10 people's fingers from outside the housing 35. In other embodiments the housing 35 may comprise as little as one or as many as five components.

The first bolt 51 passing through the top of the uppermost component 34 of the housing 35 has a pulley wheel 33 rotatably mounted thereon. A second bolt 52 passing through the opposing sides of the bottom of the lowermost component 32
15 of the housing 35 has two pulley wheels 36, 37 mounted thereon for rotation. The bolt 51 and second bolt 52 are substantially parallel in alignment.

The elastic cord 39 is attached to handle 10 by a deformable metal grip clamp 12 or other appropriate means of fastening. The elastic cord 39 then passes into the housing 35 through an aperture in the roof of the uppermost component
20 34 and around pulley wheels 36, 33, 37 (in that order). The elastic cord 39 then passes through a second aperture in the roof of the uppermost component 34 and terminates in an attachment with a hook 13. The bottom of the hook 13 has a dimension greater than the diameter of the second aperture such that the elastic cord 39, when the resistance means 30 is at rest or under extension by the user,
25 biases the bottom of the hook 13 into abutment with the roof of the uppermost component 34. The elastic cord 39 allows the user to lift handle 10 from a resting position by their thigh to full arm extension above the user's head.

An alternative handle 10 is shown in Figures 24 to 27. The handle 10 comprises a grip 5 and a U-shape tube 7. The tube 7 has an opening 9 extending
30 from an abutment 19, around the end 17 and along the inside of the U-shape to

terminate at an aperture 11. In this embodiment, the elastic cord 39 terminates at both ends in balls 15 which are dimensioned to fit through the aperture 11 and slide freely through the cavity inside the tube 7, as in Figure 26.

The handle 10 is fitted to the resistance means 30 by inserting one or both
5 balls 15 through the aperture 11. For a single ball 15, as in Figure 26, the opening 9 permits movement of the ball 15 through the inside cavity of the tube 7 until the elastic cord 39 hits the abutment 19. In this position the handle 10 is ready for use where inclination of the handle 10 toward the curved portion of the U-shaped tube 7 positively locks the ball 15 and elastic cord 39 against the abutment 19 when
10 tension is placed on the elastic cord 39. Alternatively, if double the resistance is desired, both balls 15 may be inserted into the handle.

The handle 10 is movable to a storage position, as shown in Figure 24, where the ball 15 is adjacent the aperture 11 and the U-shaped tube 7 sits on top of the resistance means 30 by the resilience inherent in the elastic cord 39.
15 Figures 28 and 29 show how the exercise device may be moved to a storage position where the common bar 20 is flipped over the top of the seat to rest on a bracket 86 which supports the chair back 102.

The second bolt 52 of each resistance means 30 is attached to a universal joint 50, preferably a ball and socket joint, which is in turn attached to a common
20 operating means 20 which acts to connect the lowermost components 32 of each resistance means 30. In practice, the user places both feet on the common operating means 20 and pushes the common operating means 20 to exercise their legs against the resistance provided by the resistance means 30.

The common operating means 20 preferably comprises a solid bar or tube,
25 however, in an alternative embodiment, shown in Figures 16 and 17, the bar or tube may be substituted by an extendable footrest 20, 21, 25 incorporating an elastic resistance means 25 which biases the extendable footrest 20, 21, 25 against extension. The elastic resistance means 25 preferably comprises an elastic cord but may alternatively be a coil spring or elastic strap.

The outer end of each footrest 20 is attached to the lowermost component 32 of the housing 35 by a universal joint 50 and bolt 52. The footrests 20 are attached together, firstly, by the elastic resistance means 25 and, secondly, a support bar 21 which allows slidable movement of the footrests 20 coaxial with the support bar 21. This sliding movement is facilitated by wheels 22 disposed on both ends of the support bar 21 and rollers 23 attached on the inside ends of the footrests 20 above the support bar 21. When a user pushes against the footrest 20 the force is distributed through the roller 23 and wheel 22 and allows the footrest to be smoothly extended against the resistance provided by the elastic resistance means 25. In this manner, the user can place each foot on each respective outer footrest 20 and perform a scissor type motion with their legs to extend the extendable footrest 20, 21, 25 against the elastic resistance means 25 and thereby exercise leg and groin muscles.

The construction of the resistance means 30, described above, means that when the user pulls the handle 10 the entire length of the elastic cord 39 is subject to extension as a single means of resistance. However, where the user pushes on the common operating means 20, considering one resistance means 30 only, the arrangement of the pulley wheels 33, 36, 37 and termination of elastic cord 39 in the hook 13 and handle 10 results in the user having to push against four elastic cord 39 sections. Thus, the resistance provided to the user in extending the resistance means 30 through the common operating means 20 is four times greater than the resistance to the user in pulling on the handle 10. Effectively this is a 4:1 ratio of resistance between common bar 20 and handle 10 extension.

The exercise device may, however, be adapted to provide different resistance ratios. For example, attaching a hook 13 on the handle 10 results in the user pulling against both ends of the elastic cord 39 and, essentially, doubles the resistance through the handles. The common operating means 20/handle 10 resistance ratio would then be 4:2. The resistance through the handles 10 may otherwise be varied by extending the resistance means 30 by pushing on the common operating means 20 to place the elastic cord 39 under tension. Extension of the elastic cord 39 through the use of the handles 10 then requires an increased effort to overcome the initial tension in the cord 39. Further, alternative

embodiments allow the addition or subtraction of pulley wheels to modify the resistance ratio.

It will be appreciated that various modifications and alterations may be made to the preferred embodiment of the portable exercise device described
5 above without departing from the scope and spirit of the invention.

It will also be understood that the term "comprises" (or its grammatical variants) as used in this specification is equivalent to the term "includes" and should not be taken as excluding the presence of other elements or features.

CLAIMS

1. An exercise device for mounting to a chair, the device including a first resistance means that includes a resilient means having a length and which resilient means is linked to first and second operating means at respective opposite ends of the resilient means whereby movement of the first and/or second operating means enables exercise against said resilient means and wherein an intermediate portion of said length is looped around a plurality of spaced pulleys such that said first and second operating means are spaced by a distance less than said length when said resilient means is at rest, and are operable, during exercise, to be spaced by a distance greater than said length.
2. An exercise device according to claim 1, wherein at least one of said plurality of pulleys is associated with the second operating means for movement therewith such that the resistance experienced by movement of the second operating means is greater than the resistance experienced by movement of the first operating means.
3. An exercise device according to claim 2, wherein the respective opposite end of the resilient means are linked to the first operating means and an abutment.
4. An exercise device according to any one of claims 1 to 3, wherein the first operating means is a handle.
5. An exercise device according to any one of the preceding claims, wherein the device includes a further resistance means.
6. An exercise device according to claim 5, wherein the second operating means of each resistance means includes a stirrup adapted for use with a user's foot.
7. An exercise device according to claim 5, wherein the second operating means is a common operating means connecting the opposite end of each

resistance means whereby movement of the common operating means is against both resilient means.

8. An exercise device according to claim 7, wherein the common operating means is a bar, rod or tube.
9. An exercise device according to claim 7, wherein the common operating means is an extendable footrest with two separate foot-receiving means adapted for relative slidable movement whereby the two foot-receiving means are biased together by a third resilient means such that movement of the two foot-receiving means enables exercise against the third resilient means.
10. An exercise device according to claim 9, wherein the slidable movement of the two foot-receiving means is coaxial with a support bar joining the two foot-receiving means.
11. An exercise device according to any one of the preceding claims, wherein the device includes removable chair-mounting means enabling removable mounting of the device to a chair for portability.
12. An exercise device according to claim 11, wherein the device is adapted to be removably mounted on a standard office chair.
13. An exercise device according to claim 12, wherein the removable mounting means further includes a central mounting device and one or more arms extending from the central mounting means and wherein the or each arm supports respective resistance means.
14. An exercise device according to claim 13, wherein the central mounting means comprises a clamp in the form of a generally cylindrical tube and wherein the or each arm is pivotable about an axis coaxial with an axis of the cylindrical clamp.

15. An exercise device according to claim 13 or 14, wherein the or each arm is pivotable between first operating positions and a second position where the or each variable resistance means is substantially flush with a chair for out-of-the-way storage.
16. An exercise device according to any preceding claim, wherein the resilient means, at rest, is located within a housing.
17. An exercise device according to claim 16, wherein the housing comprises at least one component shrouding the resilient means.
18. An exercise device according to claim 17, wherein the housing comprises at least two components that cooperate telescopically to accommodate extension of the resilient means.
19. An exercise device according to claim 18 and any one of claims 11 to 14, wherein the at least two components include an uppermost component of the housing which is pivotally attached to the removable chair-mounting means.
20. An exercise device for mounting to a chair, the device including:
- a resistance means that includes a resilient means having a length and which resilient means is linked to first and second operating means at respective opposite ends of the resilient means whereby movement of the first and/or second operating means enables exercise against said resilient means; and
- means for removable mounting of the device to a chair such that the device is portable.
21. An exercise device according to claim 20, wherein the device is adapted to be removably mounted on a standard office chair.
22. An exercise device according to claim 21, wherein the removable mounting means further includes a central mounting device and one or more arms extending

from the central mounting means and wherein the or each arm is attached to a said resistance means or via an extension bar supported by the or each arm.

23. An exercise device according to claim 22, wherein the central mounting means comprises a clamp in the form of a generally cylindrical tube and wherein the or each arm is pivotable about an axis coaxial with an axis of the cylindrical clamp.

24. An exercise device according to claim 23, wherein the or each arm is pivotable between first operating positions and a second position where the or each variable resistance means is substantially flush with a chair for out-of-the-way storage.

25. An exercise device for mounting to a chair, the device including:

a resistance means that includes a resilient means having a length and which resilient means is linked to first and second operating means at respective opposite ends of the resilient means whereby movement of the first and/or second operating means enables exercise against said resilient means; and

means for mounting the device to a chair such that the first and second operating means are displaceable between a first operating position and a second position for storage when the device is mounted to the chair and not being used.

26. An exercise device according to any one of the preceding claims, wherein the resilient means is an elastic cord or spring.

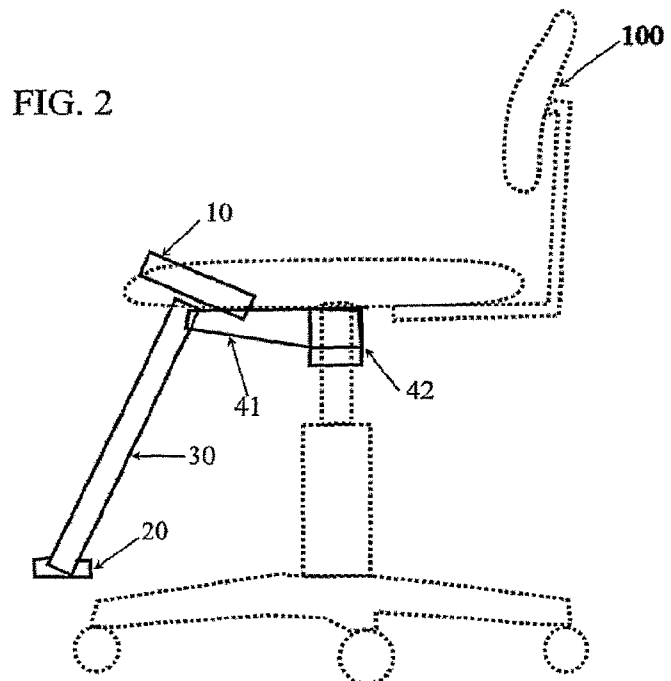
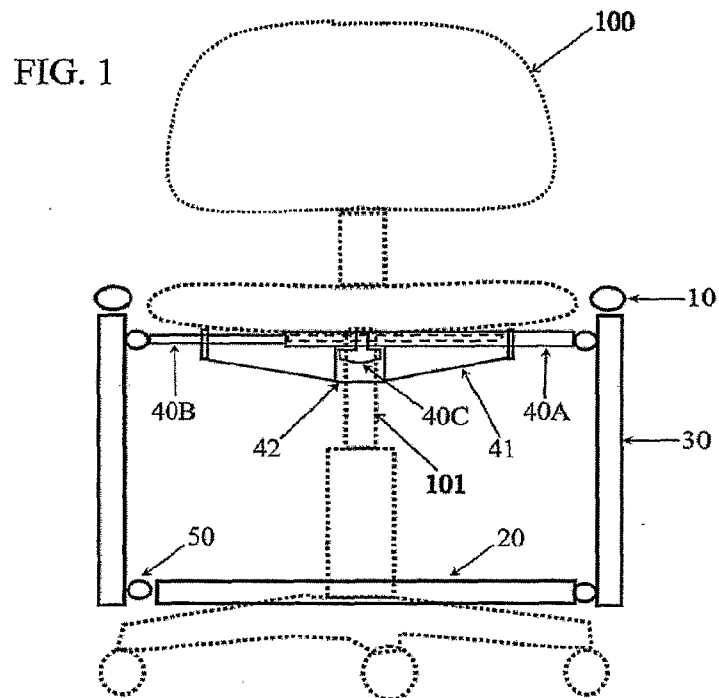

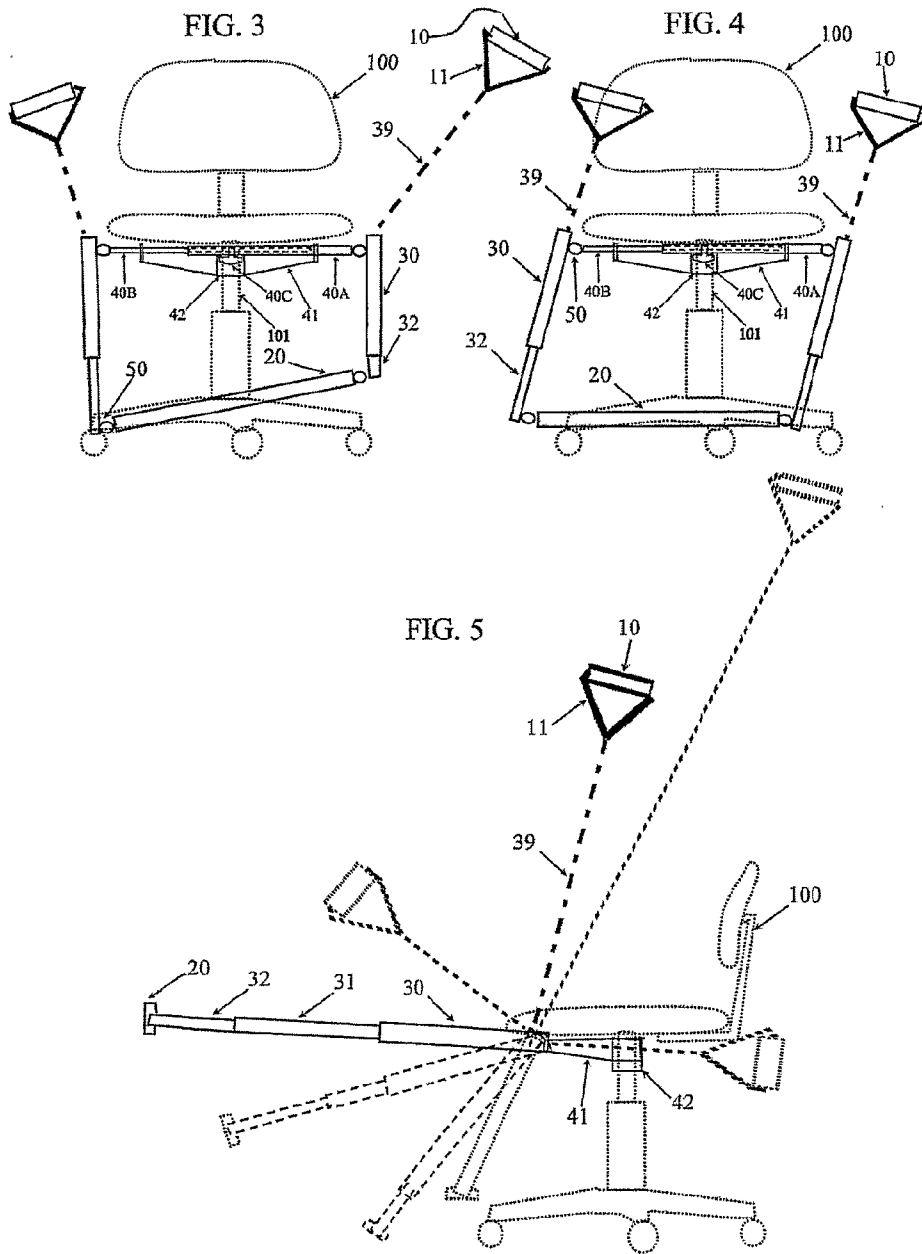

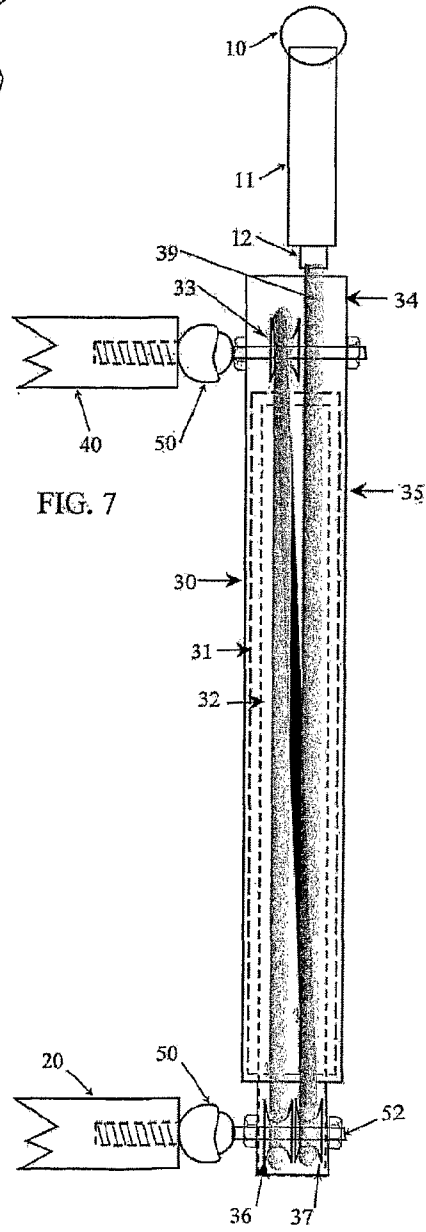
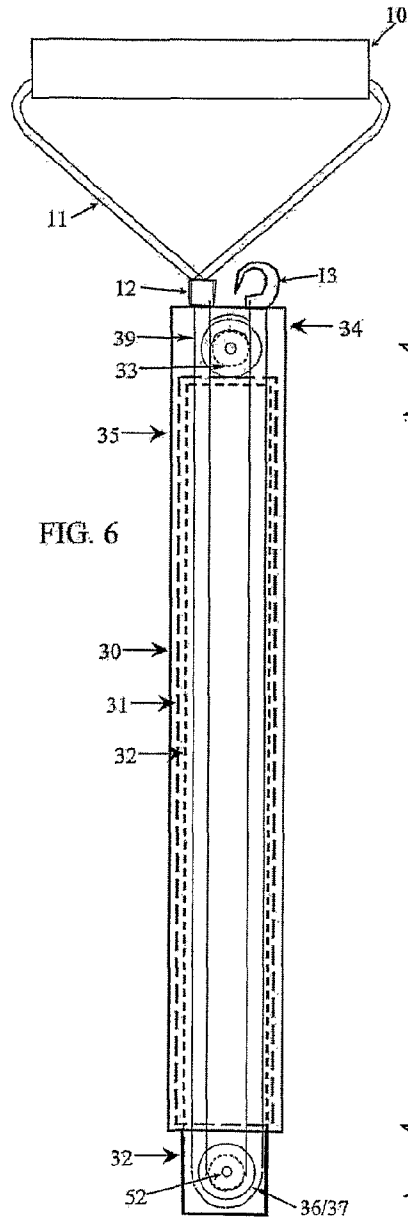

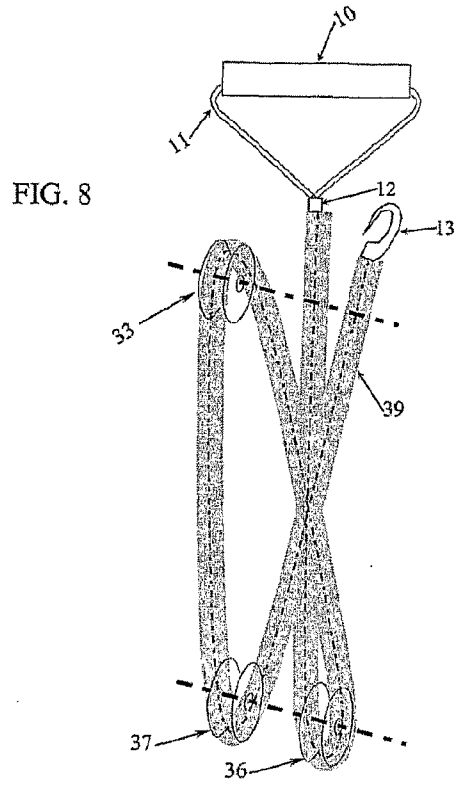
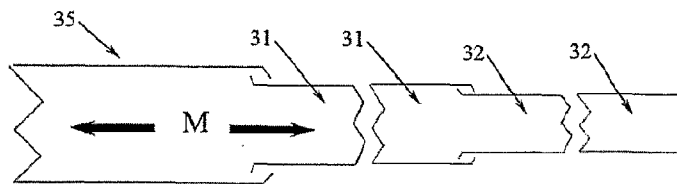

FIG. 9



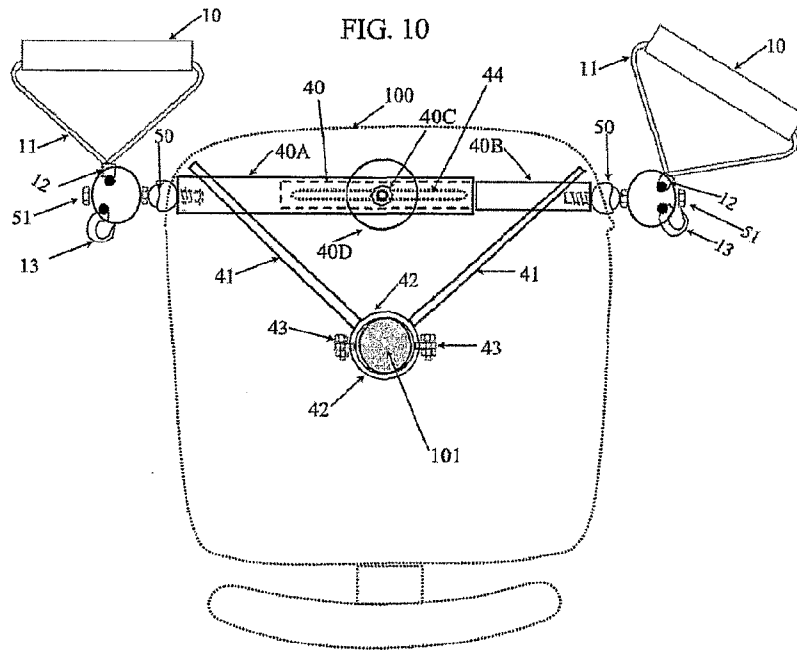

FIG. 11

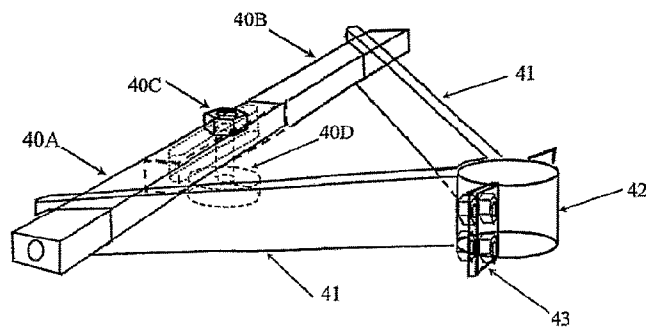

FIG. 12

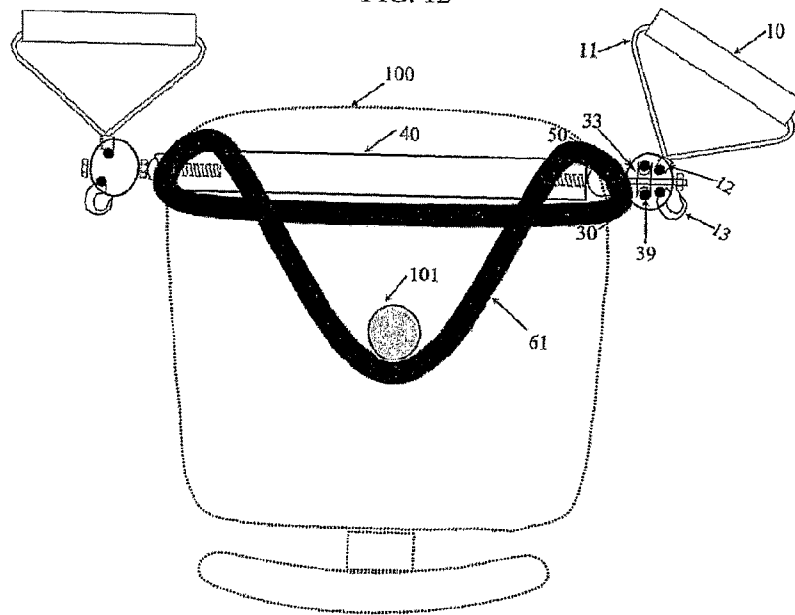

FIG. 13

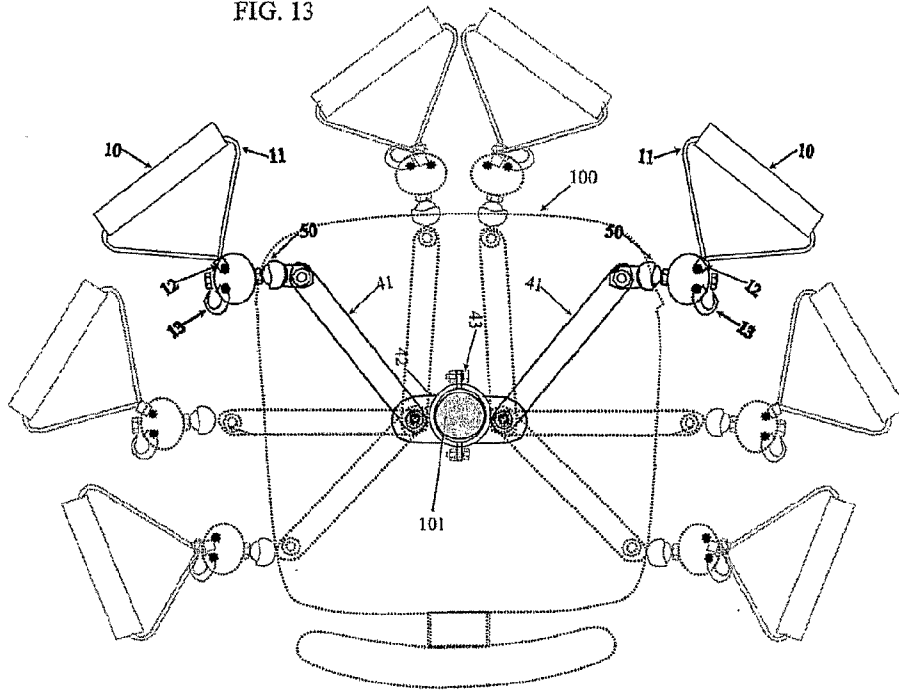

FIG. 14

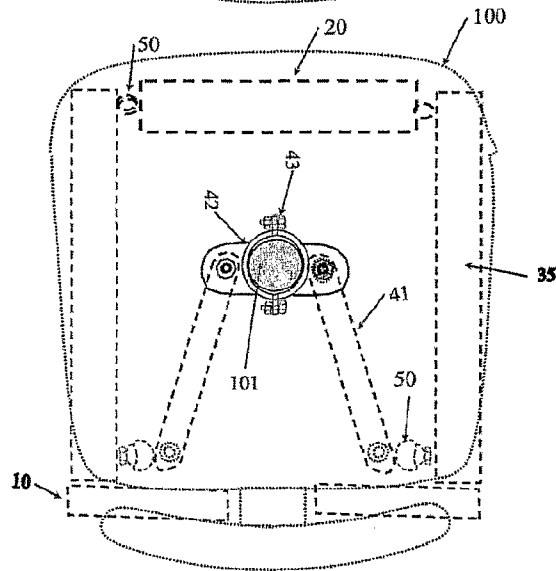

FIG. 15

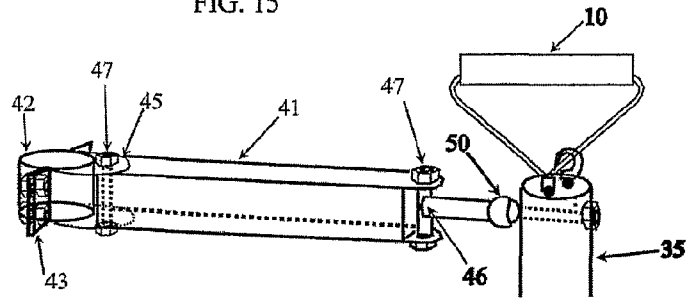

FIG. 16

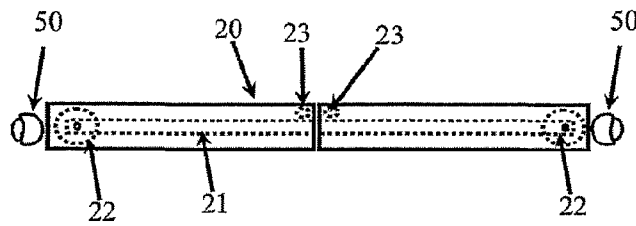

FIG. 17

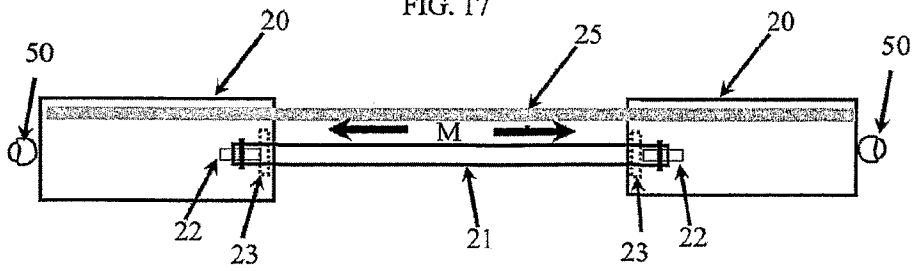

FIG. 18

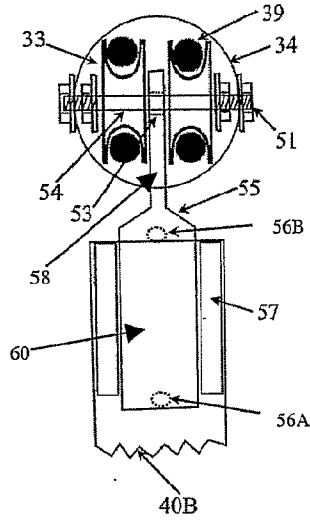

FIG. 19

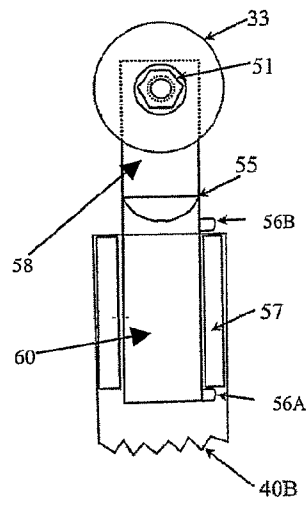

FIG. 20

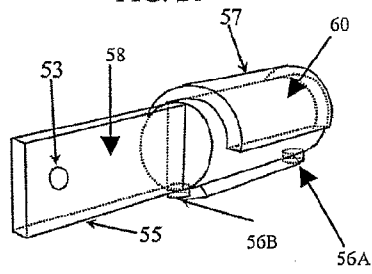
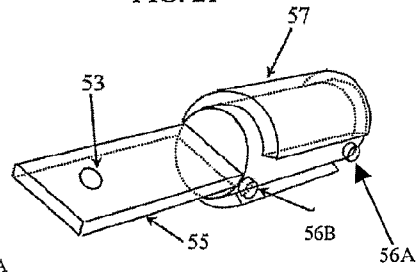

FIG. 21



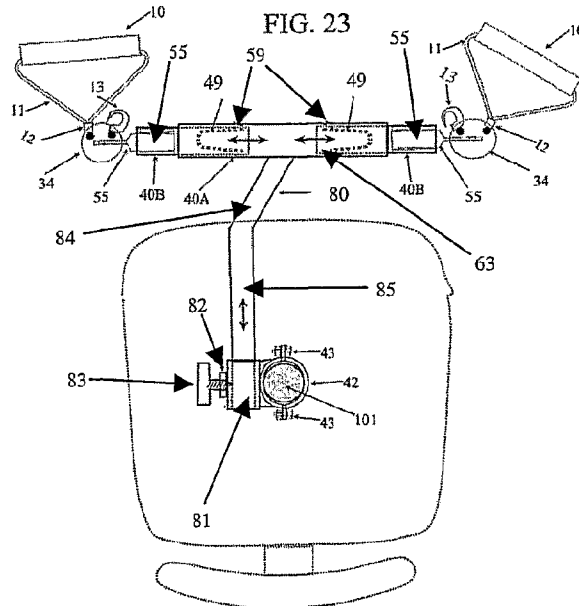
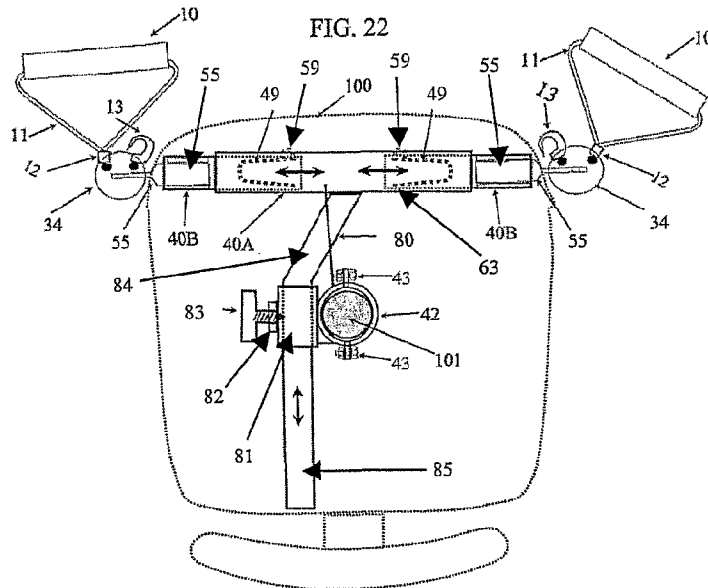

FIG. 24

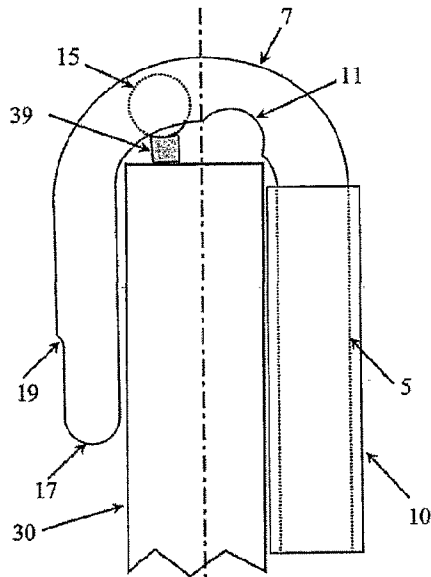

FIG. 26

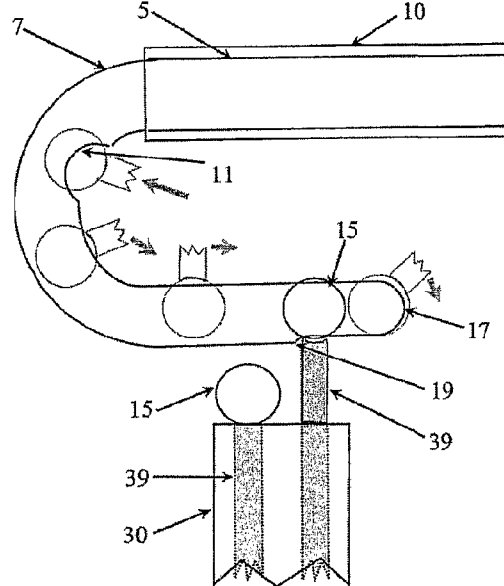

FIG. 25

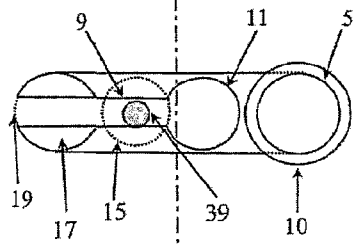

FIG. 27

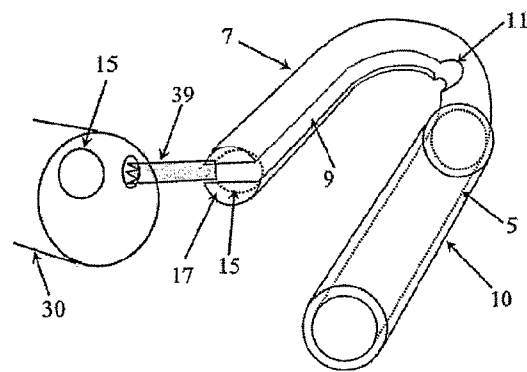

FIG. 28

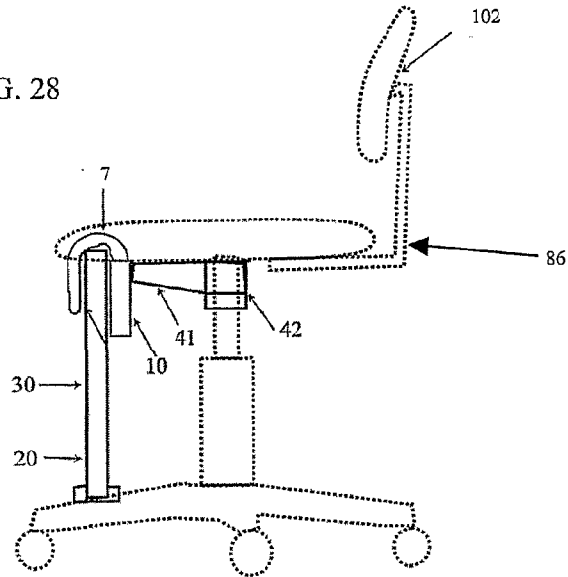

FIG. 29

