

(No Model.)

4 Sheets—Sheet 1.

N. DE BENARDOS & S. OLSZEWSKI.  
PROCESS OF AND APPARATUS FOR WORKING METALS BY THE DIRECT  
APPLICATION OF THE ELECTRIC CURRENT.

No. 363,320.

Patented May 17, 1887.

FIG. 1.

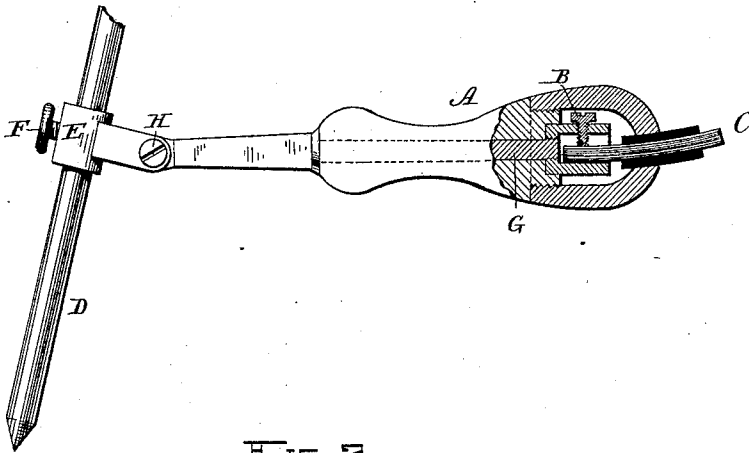
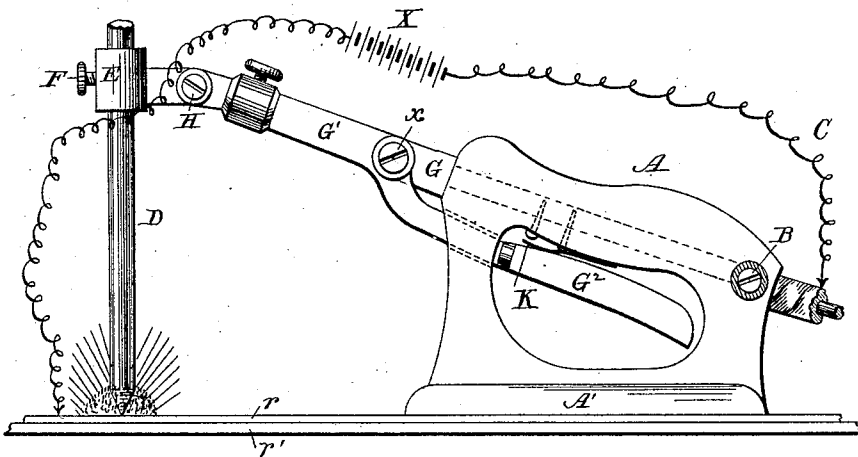

FIG. 2.



Witnesses—

*Ewell A. Rice*  
*Marvin A. Curtis*

Inventors—

*Nicholas de Benardos*  
*+ Stanislas Olszewski*  
*by Maullus S. Allen*  
*Attorney*

(No Model.)

4 Sheets—Sheet 2.

N. DE BENARDOS & S. OLSZEWSKI.

PROCESS OF AND APPARATUS FOR WORKING METALS BY THE DIRECT APPLICATION OF THE ELECTRIC CURRENT.

No. 363,320.

Patented May 17, 1887.

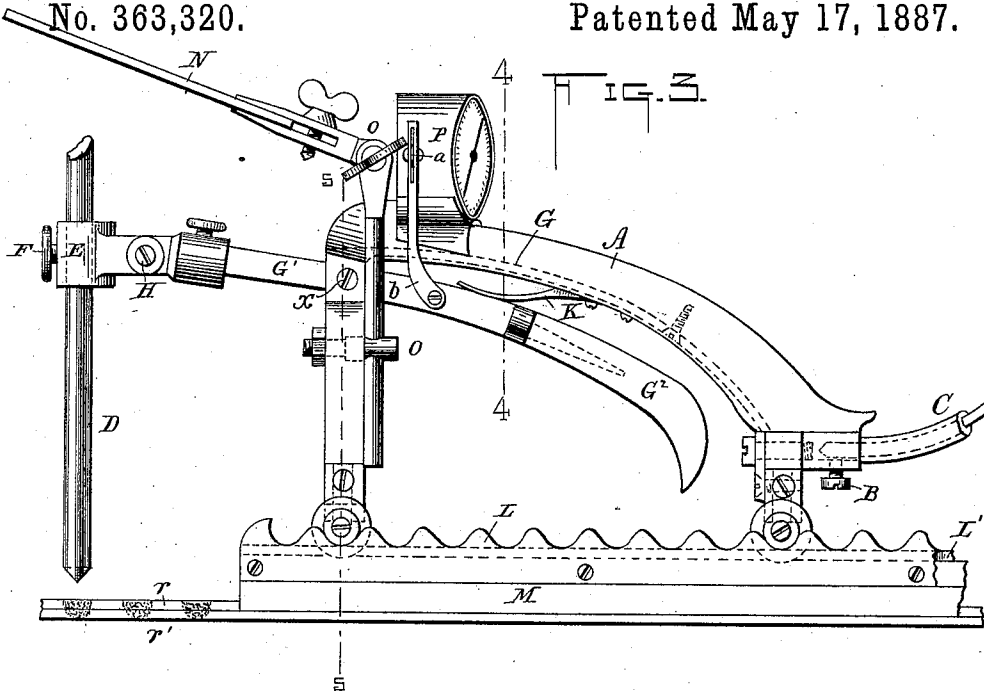
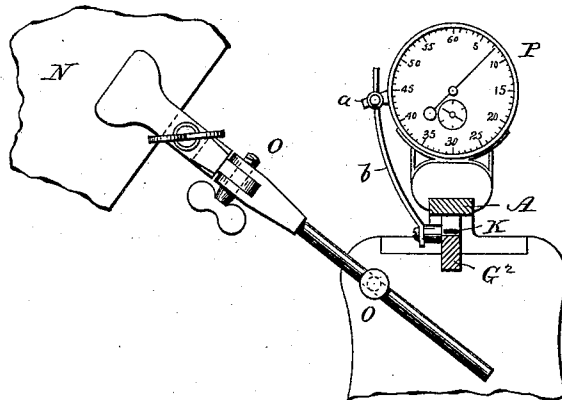

FIG. 4.



Witnesses—

*Ewald*  
*Marvin A. Lustin*

Inventors—

*Nicholas de Bernardos*  
*Stanislas Olszewski*  
 by *Marcellus Bailey*  
*attorney*

N. DE BENARDOS & S. OLSZEWSKI.

PROCESS OF AND APPARATUS FOR WORKING METALS BY THE DIRECT APPLICATION OF THE ELECTRIC CURRENT.

No. 363,320.

Patented May 17, 1887.

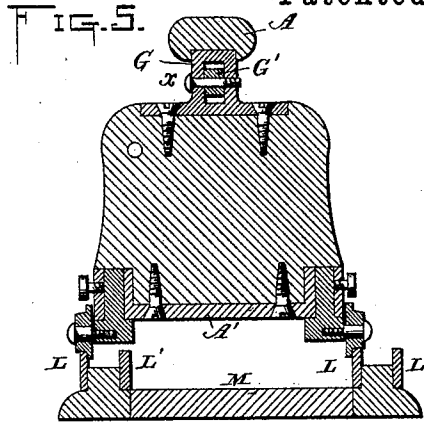

FIG. 5.

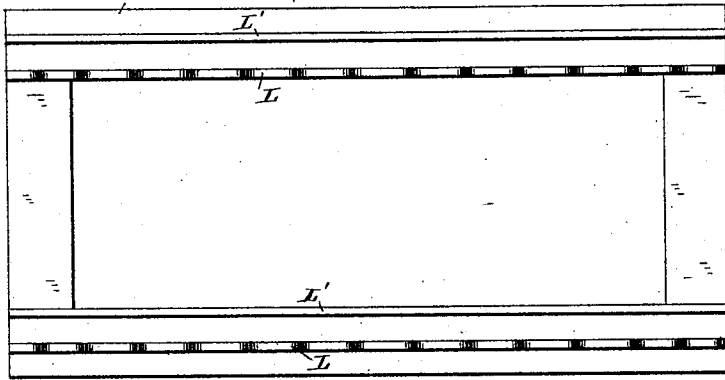

FIG. 6.

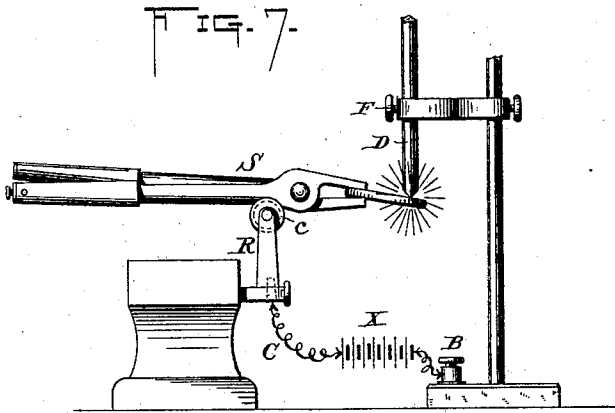

FIG. 7.

Witnesses—  
*Evelyn Dick*  
*Martin Curtis*

Inventors—  
*Nicholas de Benardos*  
*& Stanislas Olszewski*  
 by *Marcellus Bailey*  
*attorney*

(No Model.)

4 Sheets—Sheet 4.

N. DE BENARDOS & S. OLSZEWSKI.

PROCESS OF AND APPARATUS FOR WORKING METALS BY THE DIRECT APPLICATION OF THE ELECTRIC CURRENT.

No 363,320.

Patented May 17, 1887.

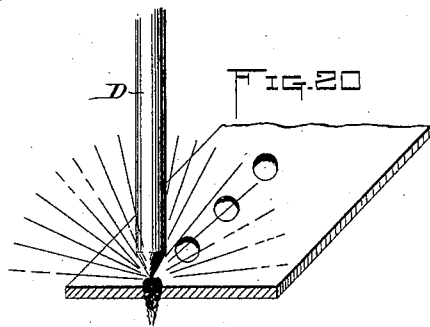
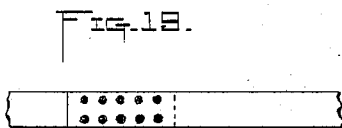
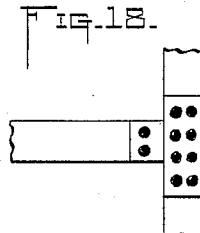
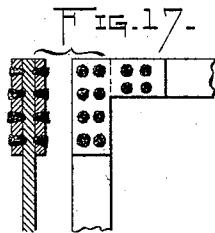
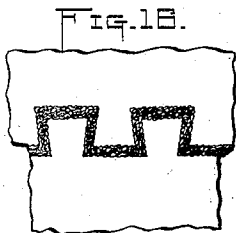
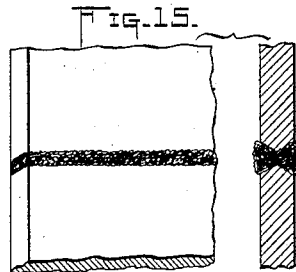
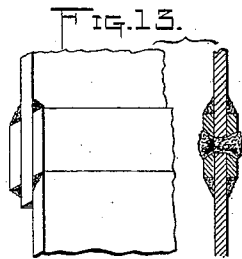
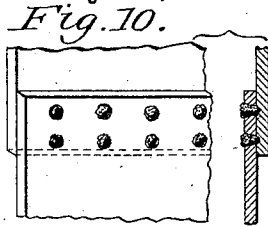

FIG. 21.

Electr

Witnesses.

*E. W. Leach*  
*Marvin A. Curtis*

Inventors.

*Nicholas de Benardos*  
*Stanislas Olszewski*  
*by Marshall Bailey*  
*Attorney*

# UNITED STATES PATENT OFFICE.

NICHOLAS DE BENARDOS AND STANISLAS OLSZEWSKI, OF ST. PETERSBURG, RUSSIA.

PROCESS OF AND APPARATUS FOR WORKING METALS BY THE DIRECT APPLICATION OF THE ELECTRIC CURRENT.

SPECIFICATION forming part of Letters Patent No. 363,320, dated May 17, 1887.

Application filed December 3, 1885. Serial No. 184,575. (No model.) Patented in France October 10, 1885, No. 171,596; in Belgium October 20, 1885, No. 70,569; in England October 21, 1885, No. 12,984; in Germany November 1, 1885, No. 38,011; in Sweden November 6, 1885, No. 726; in Russia December 31, 1886, No. 11,982, and in Spain January 5, 1887, No. 10,267.

*To all whom it may concern:*

Be it known that we, NICHOLAS DE BENARDOS and STANISLAS OLSZEWSKI, of St. Petersburg, in the Empire of Russia, have invented certain new and useful Improvements in the Process of and Apparatus for Working Metals by the Direct Application of the Electric Current, (for which we have obtained patents as follows: in France, No. 171,596, dated October 10, 1885; in Belgium, No. 70,569, dated October 20, 1885; in England, No. 12,984, dated October 21, 1885; in Russia, No. 11,982, dated December 31, 1886; in Sweden, No. 726, dated November 6, 1885; in Spain, No. 10,267, dated January 5, 1887, and in Germany, No. 38,011, dated November 1, 1885,) of which the following is a specification.

Our invention contemplates the formation or production of the voltaic arc between the metal to be operated on and a conductor which is brought for said purpose into proper proximity to that point on the metal which is to be operated on, the conductor forming one pole, while the metal to be worked constitutes in itself the other pole. In other words, the metal to be worked and the conductor extraneous to said metal constitute two electrodes or terminals, by the approach of which to each other the circuit in which both are included can be completed through the voltaic arc produced between them. It is this feature which mainly characterizes our invention, and which differentiates it from other methods which have been proposed of working or melting metals by the electric current.

The advantages attending our invention are, briefly stated, its simplicity and efficiency, as well as its wide range of application in the industrial arts.

The only apparatus needed to put this invention into practice outside of the electrical generator or source of electrical supply, and the circuit leading therefrom to the metal to be worked and to the extraneous conductor, is a holder for the said conductor, the holder and the metal to be operated on being so arranged as to be movable relatively to each

other, so as to bring the conductor opposite to any desired point on the metal. We prefer, usually, to move the conductor-holder over the metal. The conductor preferably consists of a stick or cylindrical rod of carbon. The form and material of said conductor, however, are not essential features.

In the accompanying drawings we have shown some forms of apparatus, which we will now proceed to describe, in order to more fully explain the manner in which our process can be practically applied.

Figure 1 is a side elevation, partly in section, of a simple form of carbon-holder. Fig. 2 is a like view of a holder adapted to rest upon and be moved over the face of the metal plate or plates which are to be operated on. Fig. 3 is a side elevation of a modified form of apparatus. Fig. 4 is a section on line 4 4, Fig. 3. Fig. 5 is a section on line 5 5, Fig. 3. Fig. 6 is a plan of the rails on which the holder shown in Fig. 3 is mounted. Fig. 7 is a side elevation of a form of apparatus in which the carbon is stationary and the metal to be operated on is movable under the carbon. Figs. 8 to 21 represent various applications of the invention or uses to which it may be put.

The holder shown in Fig. 1 consists of a wooden or other non-conducting handle, A, having in its rear end a socket and binding-screw, B, electrically connected to the conducting stem or shank G, to which is jointed or hinged at H a sleeve, E, containing the carbon pencil D, held in place therein by clamp-screw F. The binding-screw B serves to hold in place the metallic conductor C, which leads from one pole (usually and preferably the + pole) of the source of electricity. The other pole of said source of electricity is connected to the metal to be operated on. When the carbon D, under these conditions, is brought into proximity to the metal to be operated on, the voltaic arc will be produced between the two, with the effect of heating, softening, and finally melting the metal at the point where the arc meets it. The holder can be moved over the metal from one point to another to

act on it in a continuous line, or at separate points, as desired.

The apparatus shown in operation in Fig. 2 consists, also, of a wooden handle, A, with a metallic socket and binding-screw, B, at its rear end, metallic shank G, jointed sleeve E, clamp-screw F, and carbon pencil D, as in the preceding figure. Handle A has a flat base, A', which rests upon and can move over the two metal plates *r r'* to be operated on. The conductor C for the carbon leads from the + pole of battery X, (typical of any source of electricity, such as accumulator, battery, or dynamo,) and the other pole of said battery is electrically connected to said plates *r r'*, as shown.

The stem G is a two-part stem jointed together at *x*, and its front end, G', is continued back of the joint in the form of a lever, G<sup>2</sup>, which extends under the handle A. A spring, K, keeps the part G', and consequently the carbon D, lifted, thus maintaining a normally-open circuit. By pressing lever G<sup>2</sup> toward the handle the carbon can be lowered into proper proximity to the plates *r r'* to produce between it and them the voltaic arc. In this figure the apparatus is shown in operation uniting the two plates by a process akin to riveting. By the action of the voltaic arc the metal is gradually melted, the fusion extending through into both plates, the melted portions of which are mingled together, so that when the same cool the two plates, as to said fused portions, are virtually in one homogeneous piece.

The apparatus shown in Figs. 3, 4, 5 in the main resembles that illustrated in Fig. 2. Its base is provided with front and rear pairs of flanged wheels, which run upon either one of two pairs of rails, L L', on a track-frame, M. The rails L are cogged or toothed, as shown, and are designed to be used when the holder is employed for what may be termed "point-union"—that is to say, for operating on the metal at points whose distances from one another will be equal to the distance intervening between the teeth of the rails. The other rails, L', are ordinary straight smooth rails, and are to be used when the holder is employed for uninterrupted or continuous union. This holder is provided with a screen, N, of colored glass, attached to the holder by a universal joint at O, which will permit it to be set in any position required, in order to shield the eyes of the operator from the injurious effects of the voltaic arc. It is also provided with a secondometer or other suitable time-piece, P, having a stop-lever, *a*, connected to and arranged to be operated by an arm, *b*, attached to the handle end of vibratory stem G. Normally the handle end G<sup>2</sup> is depressed by its spring, thus lifting the carbon and breaking the circuit, and the parts are so adjusted that in this position the arm *b* will bring the stop-lever to position to stop the time-piece. When, however, the handle is pressed upward,

thus bringing the carbon into action, the stop-lever will be moved in a direction to permit the time-piece to start. In this way the duration of the operation, in the case of point-union particularly, can be accurately determined.

It will be of course understood that, instead of connecting the wire from one pole of the battery directly to the metal to be operated on, it can be connected to a metallic plate or stand, which serves as a working-bench to support the metal operated on, the two being of course in electrical contact. Such arrangement is represented in Fig. 7, the apparatus being designed for use as a forge. The stand R is furnished with a grooved guide-pulley, *c*, which receives and supports the metal tangs or shanks of pinchers S, whose handles are sheathed with wood or other insulating material. The pinchers are in electrical contact with the metal pulley, over which they can move to bring the article held by them (in this instance supposed to be a chain-link) under the carbon, which is supported in a stationary holder. The circuit-connections are the same in the other figures. The metal to be operated on can in this apparatus be heated to the desired extent, and then can be transferred to the usual anvil and forged in the customary way.

Our invention, as hereinbefore indicated, is susceptible of a wide range of application. It can be used, for instance, for joining metals whether end to end or placed one on top of the other, for making holes in metal, or for dividing a piece of metal into two or more parts, for steelifying, and for numerous other purposes.

Figs. 8 to 19 represent some of the ways in which metals may be joined by our invention. These figures require no explanation, further than to say that the darkened points or lines in them indicate where the metal has been operated on.

Fig. 20 illustrates the manner in which holes may be bored in metals.

Fig. 21 represents a metallic plate having pattern of fused metal incrustated thereon. The plate is heated to the temperature of fusion at the point where the extraneous metal is to be applied, and said metal in fused condition is dropped upon the heated point or points, thus forming a metal incrustation, which enters and becomes part of the plate. In this way we can incorporate into the plate other metals, granite, porcelain, &c.

From the foregoing it will be observed that the essence of our invention is that the metal itself at the point where it is operated on becomes one pole of the voltaic arc, while the carbon or other extraneous conductor approached thereto constitutes the other pole.

Having now described our invention and the best way at present known to us of carrying the same into effect, what we claim, and desire to secure by Letters Patent, is as follows:

1. The improvement in the art of joining or

separating metals by means of the directly-applied electric current, which consists in forming the voltaic arc at the desired point or points, or along the desired line or lines, on said metal by a conductor approached thereto, which constitutes one pole, while the metal itself constitutes the other pole, as and for the purposes hereinbefore set forth.

2. The process of topically working plates, blocks, or other solid masses of metal, which consists in forming the voltaic arc at those points only of the metal which are to be worked, (leaving the other portions of the same unaffected,) through the agency of an extraneous conductor, which constitutes one pole, while the metal itself constitutes the other pole, as and for the purposes hereinbefore set forth.

3. The carbon-carriage consisting of a frame adapted to rest on and move over the face of the metal to be worked, a carbon or other con-

ductor, a holder therefor carried by said frame and movable to and from the metal on which the frame rests, and means whereby said holder can be actuated, at will, to cause the carbon to approach or recede from the said metal, substantially as hereinbefore set forth.

4. The combination of the supporting-frame, the carbon-holder carried by and movable and adjustable on said frame, and the time-piece connected with and operated by said holder at the times and in the manner substantially as and for the purposes hereinbefore set forth.

In testimony whereof we affix our signatures in presence of two witnesses.

NICHOLAS DE BENARDOS.  
STANISLAS OLSZEWSKI.

Witnesses:

NICHOLAS TSCHEKALOFF,  
FREDERICK KAUPE.