

(12) INTERNATIONAL APPLICATION PUBLISHED UNDER THE PATENT COOPERATION TREATY (PCT)

(19) World Intellectual Property Organization  
International Bureau



(43) International Publication Date  
19 June 2003 (19.06.2003)

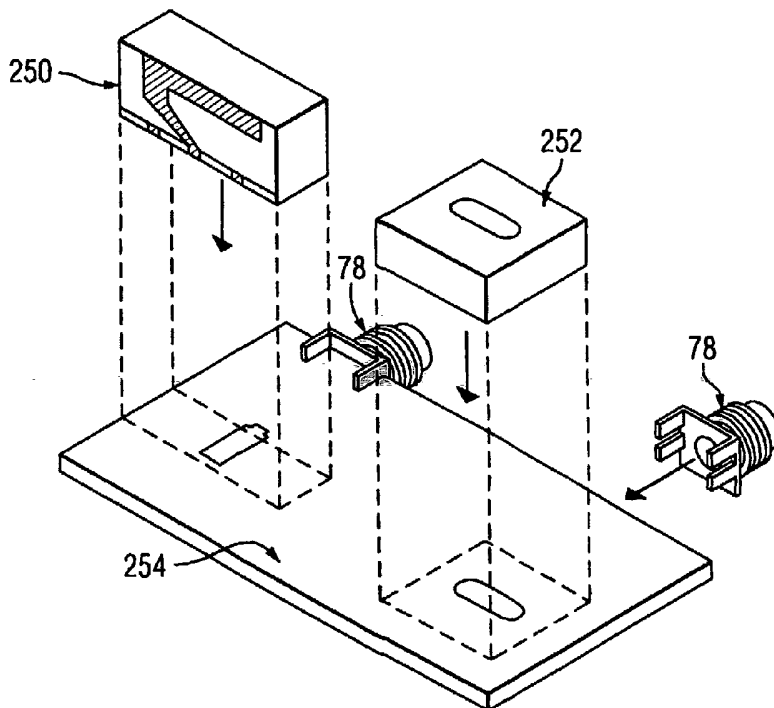
PCT

(10) International Publication Number  
**WO 03/050917 A1**

- (51) International Patent Classification<sup>7</sup>: **H01Q 21/00**, Beach, FL 32937 (US). **KRALOVEC, Jay, A.**; 724 Myrtlewood Lane, Melbourne, FL 32940 (US).
- (21) International Application Number: PCT/US02/38866 (74) Agent: **DEANGELIS, John, L., Jr.**; Beusse Brownlee Bowdoin & Wolter, P.A., 390 N. Orange Avenue, Suite 2500, Orlando, FL 32801 (US).
- (22) International Filing Date: 6 December 2002 (06.12.2002)
- (25) Filing Language: English (81) Designated States (*national*): AE, AG, AL, AM, AT, AU, AZ, BA, BB, BG, BR, BY, BZ, CA, CH, CN, CR, CU, CZ, DE, DK, DM, DZ, EE, ES, FI, GB, GD, GE, GH, GM, HR, HU, ID, IL, IN, IS, JP, KE, KG, KP, KR, KZ, LC, LK, LR, LS, LT, LU, LV, MA, MD, MG, MK, MN, MW, MX, MZ, NO, NZ, PL, PT, RO, RU, SD, SE, SG, SK, SL, TJ, TM, TR, TT, TZ, UA, UG, UZ, VN, YU, ZA, ZW.
- (26) Publication Language: English
- (30) Priority Data:  
60/338,252 7 December 2001 (07.12.2001) US  
60/364,922 15 March 2002 (15.03.2002) US
- (71) Applicant: **SKYCROSS, INC.** [US/US]; 300A North Drive, Melbourne, FL 32934 (US). (84) Designated States (*regional*): ARIPO patent (GH, GM, KE, LS, MW, MZ, SD, SL, SZ, TZ, UG, ZM, ZW), Eurasian patent (AM, AZ, BY, KG, KZ, MD, RU, TJ, TM), European patent (AT, BE, BG, CH, CY, CZ, DE, DK, EE, ES, FI, FR, GB, GR, IE, IT, LU, MC, NL, PT, SE, SI, SK, TR), OAPI patent (BF, BJ, CF, CG, CI, CM, GA, GN, GQ, GW, ML, MR, NE, SN, TD, TG).
- (72) Inventors: **GREER, Kerry, L.**; 6015 Riverside Dr., Melbourne Beach, FL 32951 (US). **CAIMI, Frank, M.**; 4375 2nd Circle, Vero Beach, FL 32965 (US). **HENDLER, Jason, M.**; 2195 Highway A1A, N° 703, Indian Harbour

[Continued on next page]

(54) Title: MULTIPLE ANTENNA DIVERSITY FOR WIRELESS LAN APPLICATIONS



(57) Abstract: An antenna system comprising a plurality of antennas (70, 76, 140, 142) designed and oriented to provide one or more of radiation pattern, signal polarization and spatial diversity. The various diversity operational characteristics are achieved by using similar antennas physically oriented to provide the diversity attributes or by using dissimilar antennas (75, 76), that is, antennas having different radiation pattern and/or signal polarization characteristics.



WO 03/050917 A1



**Published:**

— *with international search report*

*For two-letter codes and other abbreviations, refer to the "Guidance Notes on Codes and Abbreviations" appearing at the beginning of each regular issue of the PCT Gazette.*

5

## MULTIPLE ANTENNA DIVERSITY FOR WIRELESS LAN APPLICATIONS

### FIELD OF THE INVENTION

The present invention relates generally to antennas for receiving and transmitting radio frequency signals, and more specifically to such antennas that provide three-dimensional spatial diversity, signal polarization diversity and radiation pattern diversity for receiving and transmitting radio frequency signals.

### BACKGROUND OF THE INVENTION

It is generally known that antenna performance is dependent on the antenna size, shape and the material composition of certain antenna elements, as well as the relationship between the wavelength of the received/transmitted signal and certain antenna physical parameters (that is, length for a linear antenna and diameter for a loop antenna). These relationships and physical parameters determine several performance characteristics, including: input impedance, gain, directivity, polarization and radiation pattern. Generally, for an operable antenna, the minimum effective electrical length (which according to certain antenna structures, for example antennas incorporating slow wave structures, may not be equivalent to the antenna physical length) must be on the order of a quarter wavelength or a multiple thereof of the operating frequency. A quarter-wave antenna limits the energy dissipated in resistive losses and maximizes the energy transmitted. Quarter and half wavelength antennas are the most commonly used.

The radiation pattern of the half-wavelength dipole antenna is the familiar omnidirectional donut shape with most of the energy radiated uniformly in the azimuth direction and little radiation in the elevation direction. Frequency bands of interest for certain communications devices are 1710 to 1990 MHz and 2110 to 2200 MHz. A half-wavelength dipole antenna is approximately 3.11 inches long at 1900 MHz, 3.45 inches long at 1710 MHz, and 2.68 inches long at 2200 MHz. The typical antenna gain is about 2.15 dBi.

The quarter-wavelength monopole antenna placed above a ground plane is derived from a half-wavelength dipole. The physical antenna length is a quarter-wavelength, but when placed above a ground plane the antenna performance resembles that of a half-wavelength dipole. Thus, the radiation pattern for a quarter-wavelength monopole antenna above a ground plane is similar to the half-wavelength dipole pattern, with a typical gain of approximately 2 dBi.

Printed or microstrip antennas are constructed using the principles of printed circuit board techniques, where one or more of the metallization layers or interconnecting vias serve as the radiating element(s). These antennas are popular because of their low profile, ease of manufacture and low fabrication cost. One such antenna is the patch antenna, comprising a ground plane below a dielectric substrate, with the radiating element overlying the substrate top surface. The patch antenna provides directional hemispherical coverage with a gain of approximately 3 dBi.

The burgeoning growth of wireless communications devices and systems has created a need for physically smaller, less obtrusive and more efficient antennas that are capable of wide bandwidth and/or multiple frequency operation. As the size of physical enclosures for pagers, cellular telephones and wireless Internet access devices shrink, manufacturers continue to demand improved performance, multiple operational modes and smaller sizes for today's antennas.

Smaller packaging envelopes do not provide sufficient space for the conventional quarter and half wavelength antenna elements. Also, as is known to those skilled in the art, there is a direct relationship between antenna gain and antenna physical size. Increased gain requires a physically larger antenna, while users continue to demand physically smaller antennas with increased gain.

With the expansive deployment of computer resources, it has become advantageous to connect computers to allow collaborative sharing of information. Conventionally, the connection is in the form of wired computer or data networks (generally referred to as local area networks or LAN's) operating under various standard protocols, such as the Ethernet protocol. Users connected to the network can exchange data with other network users, irrespective of the physical distance between, the users. These networks, which have become ubiquitous among computer users, operate at fairly high speeds, up to about 1 Gbps, using relatively inexpensive

hardware. However, LANs are limited to the physical, hard-wired infrastructure of the structure in which the users are located.

5 During recent years, the market for wireless communications of all types has enjoyed tremendous growth. Wireless technology allows people to exchange information using pagers, cellular telephones, and other wireless communication products. With the steady expansion of wireless communications, wireless concepts are now being applied to data networks, relieving the user of the need for a wired connection between the computer and the network.

10 The major motivation and benefit from wireless LANs is the user's increased mobility. Untethered from conventional network connections, network users can access the LAN from wireless network access points strategically located within a structure or on a campus. Depending on the antenna gain, available signal power, noise and interference, wireless local area networks can operate over a range of several hundred feet to a few thousand feet. Frequently it is more economical to  
15 install a wireless LAN than to install a wired network in an existing structure. Wireless LANs offer the connectivity and the convenience of wired LANs without the need for expensive wiring or rewiring.

20 The Institute for Electrical and Electronics Engineers (IEEE) standard for wireless LANs (IEEE 802.11) sets forth two different wireless network configurations: ad-hoc and infrastructure. In the ad-hoc network, computers are brought together to form a network "on the fly." There is no structure to the network and there are no fixed network points. Typically, every node is able to communicate with every other node. The infrastructure wireless network uses fixed wireless network access points with which mobile nodes can communicate. These wireless  
25 network access points are typically bridged to landlines to allow users to access other networks and sites not on the wireless network.

30 The IEEE 802.11 standard governs both the physical (PHY) and medium access control (MAC) layers of the network. The PHY layer, which handles the transmission of data between nodes, can use either direct sequence spread spectrum, frequency-hopping spread spectrum, or infrared (IR) pulse position modulation. IEEE 802.11 makes provisions for data rates of either 1 Mbps or 2 Mbps, and calls for operation in the 2.4-2.4835 GHz frequency band (which is an unlicensed band for

industrial, scientific, and medical (ISM) applications) and 300-428,000 GHz for IR transmission.

5 The MAC layer comprises a set of protocols that maintain order among the users accessing the network. The 802.11 standard specifies a carrier sense multiple access with collision avoidance (CSMA/CA) protocol. In this protocol, when a node receives a packet for transmission over the network, it first listens to ensure no other node is transmitting. If the channel is clear, the node transmits the packet. Otherwise, the node chooses a random "backoff factor" that determines the amount of time the node must wait until it is allowed to retry the transmission.

10 Several extensions of the IEEE 802.11 standard have been developed. The first, referred to as 802.11a, provides a data rate of up to 54 Mbps in the 5 GHz frequency band. The 802.11a standard requires an orthogonal frequency division multiplexing encoding scheme, rather than the frequency hopping and direct sequence spread schemes of 802.11. The 802.11b standard (also referred to as 802.11 high rate or Wi-Fi) provides a 11 Mbps transmission data rate, with a fallback to data rates of 15 5.5, 2 and 1 Mbps. The 802.11b scheme uses the 2.4 GHz frequency band, using direct sequence spread spectrum signaling. Thus 802.11b provides wireless functionality comparable to the Ethernet protocol. The newest standard, 802.11g provides for a data rate of 20+ Mbps in the 2.4 GHz band. A primarily European 20 wireless networking standard similar to the 802.11 standards, referred to as HyperLAN2, operates at 5.8 MHz.

Today, devices implementing either the 802.11a or 802.11b standard are available. The higher data rate of 802.11a devices can support bandwidth hungry applications, but the higher operating frequency limits the radio range of the 25 transmitting and receiving units. Typically, 802.11a compliant radios can deliver 54 Mbps at distances of about 60 feet, which is far less than the 300 feet radio range over which the 802.11b systems can operate, albeit at lower data rates. Thus 802.11a installations require a larger number of media access points from which users link into the network.

30 Recognizing the transient nature of a wireless signal link due to movement of the communicating devices relative to each other (typically, the base station antenna is permanently mounted while the portable device with its attendant antenna is

movable relative to the base station antenna), and the time varying properties of noise that can affect system performance, various schemes have been proposed to ensure that signals are received over the link with a sufficient ratio of bit energy to noise spectral density to allow recovery of the data. Antenna spatial diversity is one such

5 scheme, employing two antennas at the transmitting and/or receiving device, with selection of the operative antenna based on one or more monitored signal quality metrics. Thus, for example, the antenna providing the largest signal power or signal-to-noise ratio can be selected as the operative antenna. The primary objective of an antenna diversity system is to reduce signal fading caused by multipath signals that

10 can coherently cancel at the antenna, thereby reducing the received signal quality and making signal decoding more difficult and prone to error. For example, as a portable unit employing a single antenna is moved or as the signal path changes dynamically in length and/or angle due to motion of the scattering or reflecting surfaces relative to the portable unit, the multipath signals received at the antenna can destructively

15 interfere. (The signals can also constructively interfere.) In addition, the transmission medium itself (the atmosphere) can produce variations that are manifest as fades at a receiver employing only a single antenna.

In the prior art spatial diversity system the maximum allowable distance between the antennas is dependent on the available space. For example, if the

20 antennas and associated receiving and transmitting circuitry are assembled onto a PCMCIA card for insertion into a laptop computer, then the separation will be on the order of a few inches. If the antennas are mounted for use with a desktop computer the spatial separation can be on the order of several inches or a few feet. Although these dimensions can be on the order of a fraction of a wavelength at current wireless

25 frequencies, the use of spatially diverse antennas can still achieve improved performance.

The signals received at two spatially diverse antennas differ in phase and amplitude due to the distance between the antennas. The two received signals can be summed to produce a stronger received signal, or a selection process can determine,

30 based on one or more predetermined received signal metrics, which of the two antenna signals should provide the input to the receiver circuitry (or which of the two antennas should transmit the signal). Monopole antennas above a ground plane or

dipole antennas are conventionally used in these spatial antenna diversity applications.

If a multipoint reception system is used (often called a multi-branch reception system in the art), and the signals are uncorrelated at each branch (for instance, by using separate diverse locations for the antenna reception points as discussed above) the signal fading problem can be reduced. This fade reduction results from the statistical independence of the signal branches, so that as one branch fades, the probability that the other branch is also fading is small.

Polarization diversity is achieved using two linearly polarized antennas mounted orthogonally. Thus the diversity scheme relies upon the independent polarization of two or more reception branches to achieve a reduction in signal fading. The statistical independence of the branches is due to the changes in electromagnetic wave polarization as the waves are scattered and reflected along different propagation paths to the receiving antenna.

15

#### BRIEF SUMMARY OF THE INVENTION

An antenna system provides various diversity characteristics according to the teachings of the present invention. Signal polarization diversity is provided by differential orientation of two similar antennas or by the use of antennas having different signal polarization. Spatial diversity is achieved by placing the antennas in a spaced-apart configuration. Radiation pattern diversity results from the use of two antennas with different patterns or by opposingly orienting two antennas with the same radiation pattern.

20

#### BRIEF DESCRIPTION OF THE DRAWINGS

The foregoing and other features of the invention will be apparent from the following more particular description of the invention, as illustrated in the accompanying drawings, in which like reference characters refer to the same parts throughout the different figures. The drawings are not necessarily to scale, emphasis instead being placed upon illustrating the principles of the invention.

25

Figure 1 illustrates two meanderline loaded antennas operative in an antenna diversity system;

30



Figure 2 illustrates a meanderline loaded antenna suitable for inclusion in the system of Figure 1;

Figure 3 illustrates another embodiment of an antenna diversity system according to the teachings of the present invention;

5           Figures 4 – 7 illustrate various views and internal elements of an antenna suitable for operation in the antenna diversity system of Figure 3;

Figure 8 illustrates another embodiment of an antenna diversity system according to the teachings of the present invention;

10           Figure 9 illustrates another embodiment of an antenna diversity system according to the teachings of the present invention;

Figures 10 – 15 illustrate various views and internal elements of an antenna suitable for use in the antenna diversity system of Figure 9;

Figure 16 illustrates an antenna suitable for use in the antenna diversity system of Figure 9; and

15           Figure 17 illustrates yet another embodiment of an antenna diversity system according to the teachings of the present invention.

#### DETAILED DESCRIPTION OF THE INVENTION

20           Before describing in detail the particular antenna diversity scheme in accordance with the present invention, it should be observed that the present invention resides primarily in a novel combination of hardware elements related to an antenna diversity system. Accordingly, the hardware elements have been represented by conventional elements in the drawings, showing only those specific details that are pertinent to the present invention, so as not to obscure the disclosure with structural  
25           details that will be readily apparent to those skilled in the art having the benefit of the description herein.

30           According to the teachings of the present invention, an antenna system comprises two or more antennas providing diversity reception and transmission, in one embodiment, through radiation pattern diversity. The resulting operational robustness has not heretofore been achievable with prior art spatial diversity antenna systems. The present invention offers antenna gain achievable by the appropriate selection of a receiving/transmitting branch, where each branch represents an antenna

exhibiting different radiation patterns. That is, antennas exhibiting different patterns, if individually designed for efficient operation, have gain in excess of an isotropic antenna, and can effectively increase the signal energy received from (or transmitted to) a particular direction. If the antenna selected from among one or more radiation pattern diverse antennas has gain in the desired direction, then an advantage is obtained over an isotropic (unity gain) antenna and over two spatially diverse antennas. For example, it is known that the radiation pattern of an antenna transmitting in free space is different from the pattern of the same antenna transmitting in a structure with a plurality of interior walls. Thus a receiving antenna system providing pattern diversity can overcome the effects of radiation pattern distortions from the transmitter by providing a selectable radiation pattern at the receiver.

The radiation pattern diversity of the present invention is based on the use of two or more antennas with minimally or non-overlapping (i.e., different) radiation patterns to provide better overall pattern coverage for the communications device with which the antennas are associated. In one embodiment, the two pattern diverse antennas comprise a monopole antenna above a ground plane, with the familiar donut shape pattern, and a patch antenna with maximum radiation substantially perpendicular to the plane of the patch. In another embodiment the radiation pattern diverse antennas comprise similar antennas having similar radiation patterns, but physically oriented along different axes such that the radiation patterns are diverse. For example, two patch antennas offset by 90 degrees provide pattern diversity with one antenna beam in the vertical direction and the other directed in the azimuth direction, albeit subtending a relatively small arc in the azimuth direction.

In another embodiment the two dissimilar antennas are oriented to provide signal polarization diversity, so that both pattern and polarization diversity are achieved. The patch antenna and the monopole above a ground plane can be mounted with different orientations to transmit or receive differently polarized signals. Also, two monopole antennas displaced by 90 degrees with respect to each other provide signal polarization diversity.

Thus the antenna system of the present invention offers multiple antenna diversity (i.e., combinations of one or more of signal polarization, radiation pattern (or

gain) and spatial diversity) according to the teachings of the present invention. As applied to PCMCIA cards, for instance, the employed antennas according to the present invention are physically small, and therefore suitable for mounting in the limited space envelope of a PCMCIA card for use in the wireless applications described above. Thus multiple reception/transmission branches or paths, providing a combination of one or more of signal polarization, radiation pattern and spatial diversity, is possible in the limited space afforded by the PCMCIA card, with commensurate performance improvement of the communications device operative with the antenna system of the present invention.

Conventional wireless local area networks as described above often provide for the use of two antennas at the portable or mobile unit, by including two antenna ports. Thus an antenna system according to the present invention where two antennas are designed and/or oriented to provide signal polarization or radiation pattern diversity can be connected to the antenna ports to improve performance. Additionally, the antennas can be placed in spatially diverse locations to provide spatial diversity.

According to the present invention, therefore, combined diversity attributes are provided to offer as many different signal states as possible, by increasing the number of diversity branches available in a small space. The more signal states or branches that are available, the lower the probability that a received signal cannot provide a acceptable power to noise ration to allow accurate decoding.

The physically small meanderline antennas described below, when used in a diversity system of the present invention, offer additional space reductions, plus the signal polarization and radiation pattern diversity not available in the prior art. These meanderline antennas can also be separated in space to achieve the added advantage afforded by spatial separation/diversity.

According to one embodiment of the present invention, the antennas employed to provide the beam pattern and the signal polarization diversity can be constructed as meanderline-loaded antennas, wherein variable impedance transmission lines, also referred to as meanderlines, interconnect various radiating elements so that the antenna can be constructed in a physically smaller volume while offering acceptable performance parameters at the desired operating frequency or frequencies.

Meanderline antennas that can be used in this embodiment include those described in the following issued patent and patent applications, all of which are incorporated herein by reference: U.S. Patent Number 5,790,080, entitled MeanderLine Loaded Antenna; the commonly-owned pending U.S. patent application entitled Low Profile, High Gain Frequency Tunable Variable Impedance Transmission Line Loaded Antenna filed on May 31, 2001 bearing application number 09/871,201; and commonly-assigned U.S. Patent Number 6,429,820 entitled High Gain, Frequency Tunable Variable Impedance Transmission Line Loaded Antenna Providing Multi-Band Operation.

As discussed in the references, these antennas provide frequency-dependent radiation pattern characteristics. For example, at certain frequencies or within certain frequency bands the meanderline antenna produces substantial radiation from the side elements and thus the radiation pattern is the familiar omnidirectional donut pattern. At a different frequency, the same antenna operates in a mode such that the majority of the radiation is produced substantially in the elevation direction.

Polarization diversity is achieved by mounting one of the meanderline loaded antennas in a vertical orientation with the other mounted in a horizontal orientation. Although this physical configuration provides maximum signal polarization differentiation, other antenna orientations can be employed to offer the desired degree of polarization diversity.

Thus, using these meanderline-loaded antennas in an antenna diversity arrangement offers nearly unlimited possibilities for radiation pattern, signal polarization, and spatial diversity, operating in combination. That is, the radiation pattern, location, and signal polarization characteristics of the antennas can be established to produce the desired antenna performance characteristics in any one or more of three dimensions with the objective of improving performance of the receiving or transmitting communications device.

Figure 1 illustrates an exemplary embodiment where two meanderline loaded antennas 12 and 14 (including their respective ground planes 16 and 18) are mounted to a circuit card 20, such as a PCMCIA card for providing wireless communicating capabilities for a laptop computer. In another embodiment, the ground planes surfaces of the circuit card are employed and thus the separate ground planes 16 and

18 are not required. The meanderline-loaded antenna 12 is mounted horizontally to provide a horizontally polarized signal and the meanderline loaded antenna 14 is mounted vertically to provide vertical polarization, i.e., for receiving vertically polarized signals with minimized losses or transmitting vertically polarized signals.

5 Further, switching between the meanderline loaded antennas 12 and 14 or taking a weighted sum of the signal each receives provides a degree of radiation pattern diversity not available in the prior art. The meanderline loaded antennas 12 and 14 are also spaced apart by a fraction of a wavelength to provide spatial diversity.

10 A controller 22 responsive to the meanderline loaded antennas 12 and 14 provides the switching or summing functions on the signals received by or transmitted from the meanderline loaded antennas 12 and 14 to optimize the signal according to a selected signal quality metric. The elements of the controller 22, whether implemented in software or hardware are known in the art. In the application where the meanderline loaded antennas 12 and 14 are mounted to a circuit card 20, as  
15 illustrated in Figure 1, the controller 22 can be collocated on the card 20 or implemented in software within the laptop computer with which the PCMCIA card operates.

20 One example of a meanderline loaded antenna 12 is illustrated in Figure 2, wherein the meanderline loaded antenna 12 comprises a horizontal element 30 spaced apart from two vertical elements 32 and 34, creating gaps 36 and 38 therebetween. Meanderline couplers (that is, variable impedance transmission lines) 40 and 42 are electrically connected across the gaps 36 and 38, respectively. A ground plane 44 is also shown. In this embodiment the signal is fed to the meanderline loaded antenna 12 (or received from when operative in the receiving mode) through the vertical  
25 element 32; the vertical element 34 is connected to the ground plane 44. Other meanderline antennas, including those set forth in the referenced issued patents and patent applications can be used in lieu of the meanderline loaded antenna 12.

30 Figure 3 illustrates a monopole antenna 70 comprising a substantially linear radiating or launching element disposed on a printed circuit board 72, having a ground plane 74 formed thereon. A region 75 of the ground plane 74 is removed in the vicinity of the monopole antenna 70 as shown.

A monopole antenna 76 (for instance a Goubau antenna) is disposed perpendicular to the printed circuit board 72. The radiation pattern of the antenna 76 is omnidirectional in the azimuth plane, i.e., the donut pattern, with the axis of the pattern perpendicular to the printed circuit board 72. The signal is vertically polarized.

One example of a Goubau antenna suitable for use as the monopole antenna 76 is illustrated in Figures 4 through 7. This antenna offers a low cost, monolithic, surface mountable, antenna for integration into receive and transmit mother boards, e.g., PCMCIA cards. Further details of the Goubau antenna can be found in the commonly-owned provisional patent application entitled, Apparatus and Method for Forming a Monolithic Surface-Mountable Antenna, filed on August 22, 2002 and assigned application number 60/405,039, which is hereby incorporated by reference.

Figure 4 is a perspective view of a Goubau antenna 90 comprising in stacked relation a ground plane 92, a dielectric layer 94, a conductive mid-layer 96, a dielectric layer 98 and a top layer 100. The top layer 100 comprises a plurality of conductive segments 100A through 100D. Two opposing segments 100A and 100C are electrically connected to the ground plane 92 by way of conductive ground vias 108. Two opposing segments 100B and 100D are each connected to a conductive signal via 110, each of which is in turn responsive to the signal to be transmitted in the transmitting mode and provides the received signal in the receiving mode. The conductive vias 108 and 110 are interconnected in the conductive mid-layer 96 as will be further described below. The ground plane 92 and the top layer 100 are formed from printed circuit board material that has been masked, patterned and etched to form the desired features. In the transmit mode, the conductive vias 108 and 110 are the primary radiating elements. In the receiving mode, they are the primary receiving elements.

Figure 5 is a top view of the top layer 100. It is clear from this Figure that the signal vias 110 are slightly smaller in diameter than the ground vias 108, although this is not necessarily required for operation of the antenna 90. Although the four conductive segments 100A-100D are illustrated, other embodiments can have more or fewer conductive segments and corresponding desirable operating characteristics. For example, the antenna radiation resistance is a direct function of the square of the

number of segments. As the radiation resistance increases relative to the antenna reactance (energy stored in the antenna and not radiated), the Q factor of the antenna declines and the operational bandwidth increases.

Figure 6 is a bottom view, illustrating the ground plane 92, the ground via 108 and the signal vias 110. As can be seen, there is a region 112, surrounding the signal vias 110, from which the conductor forming the ground plane 92 has been removed. Within the region 112 a conductive pad 114 interconnects the signal vias 110. Thus in the transmitting mode a signal is supplied to the antenna 90 between the ground plane 92 and the signal vias 110 (which are electrically identical to the conductive pad 114). In the receiving mode the received signal is supplied between these same two points.

Figure 7 is a top view of the conductive mid-layer 96, including a conductive trace 120 interconnecting the ground vias 108 and the signal vias 110.

As described above, the antenna 90 displays an omnidirectional pattern in the azimuth direction, with most of the energy radiated from the ground vias 108 and the signal vias 110. Little energy is radiated from the top plate 100 and the ground plane 92.

Returning to Figure 3, radio frequency connectors 78 electrically connected to the monopole antennas 70 and 76 (and connected to the ground plane 74) provide the signal to be transmitted by the antennas when operative in the transmitting mode and provide the received signals to receiving circuitry when operative in the receive mode. In another embodiment, the connectors 78 are replaced by conductive traces formed on the printed circuit board 72. For example, if the printed circuit board 72 comprises a PCMCIA card for insertion into a laptop computer for operation in conjunction with a wireless LAN, the antennas 70 and 76 are connected to signal receiving and transmitting circuitry via conductive traces on the printed circuit board 72.

The radiation pattern of the monopole antenna 70 is the familiar omnidirectional donut pattern with the donut in a vertical plane, i.e., the axis of the pattern parallel to the plane of the printed circuit board 72. The radiation pattern of the monopole antenna 76 is also a donut pattern but the donut is in the horizontal plane, i.e., substantially parallel to the plane of the printed circuit board 72. The use of the two antennas 70 and 76 in a switched configuration provides for switched

radiation pattern diversity, in this embodiment more specifically referred to as switched spherical pattern diversity, because the combined radiation pattern of the antennas 70 and 76 approximates a sphere. To determine which of the two antennas offers better operation, when operative in the receiving mode a signal performance metric is determined for the received signal using each of the antennas 70 and 76. The antenna providing the better metric value is selected as the receiving antenna. This function can be performed by the aforementioned control circuitry 22. A similar signal metric determination is made when the monopole antennas 70 and 76 are operative in the transmitting mode, at a receiving device separated from the antennas 70 and 76. A signal is returned to the transmitter to advise which of the two antennas 70 and 76 is providing the better received signal. This antenna is then selected as the transmitting antenna by operation of the controller 22. It is noted that because the antennas 70 and 76 are physically separated, they also provide spatial diversity, and thus the measured signal metric is influenced by the spatial location of each antenna relative to the incoming or outgoing signal. The monopole antennas also provide signal polarization diversity because they are oriented perpendicular with respect to each other.

According to the embodiment of Figure 8, two monopole antennas 140 and 142 (for example, implemented as the Goubau antenna 90 described above), which exhibit a relatively wide operational bandwidth, are mounted on a printed circuit board 144, which also serves as a ground plane. The radiation pattern of each antenna 140 and 142 is a donut pattern, with both patterns oriented parallel to the plane of the printed circuit board 144. Since the two antennas are spatially separated, they offer a switched spatial diversity for an incoming or outgoing signal. For example, due to the signal fading affects discussed above, a signal null may occur at the antenna 140. In which case, the antenna 142 is switched to the operative mode to receive the incoming signal. As referred to above for the antennas of Figure 3, other signal metric parameters can be used to determine the operative antenna between the antennas 140 and 142. In another embodiment, not illustrated, one of the antennas 140 and 142 can be rotated by 90 degrees so that the axis of the donut patter is parallel to the plane of the printed circuit board 144 to provide radiation pattern diversity.



Figure 9 illustrates two antennas 149 and 150 that each transmit (or receive) a highly linearly polarized signal from their top surfaces 152 and 153, respectively, in a relatively narrow beam toward the zenith. Although the radiation patterns of the antenna 149 and 150 slightly overlap, the antennas are oriented orthogonal to each other to provide signal polarization diversity in the zenith direction. This embodiment is recommended for applications in which the required beam angle is narrow, but the polarity of the received signal is unknown due to signal scattering between the transmitter and the receiver. The antennas 149 and 150 are mounted on a printed circuit board 154, which also provides a ground plane function.

Figures 10 and 11 illustrate a low profile dielectrically loaded meanderline antenna 170 suitable for use as either or both of the antennas 149 and 150 of Figure 9. The antenna 170 is constructed of three dielectric layers 180, 182 and 184, a top plate 186, a feed plate 188 and a ground plate 190. By using the dielectric material to load the antenna, as compared to an air-loaded antenna, the overall antenna size is reduced for a given operational frequency. Also, it is not required that the three layers 180, 182 and 184 have equal dielectric constants. In one embodiment the dielectric layer 182 is composed of a material with a higher dielectric constant to increase the effective electrical length of the antenna 170 without increasing its physical dimensions. The dielectric layers 180 and 184 have patterned conductive material on the interior-facing surface thereof, i.e., referred to as patterned surfaces 192 and 194, respectively, as described further below. Preferably, the middle dielectric layer 182 has no conductive surfaces.

Loading the meanderline antenna 170 with a solid dielectric material allows the employment of repeatable manufacturing steps, which in turn provides improved quality control over the various antenna dimensions and assures realization of the expected level of antenna performance. Printed circuit board fabrication techniques (e.g., masking, patterning and etching) are employed to form the patterned layers 180 and 184, and the various conductive surfaces of the antenna 170.

To provide an antenna ground plane surface, the ground plate of the antenna 170 contacts the ground plane of the printed circuit board 154, by way of ground contacts 196 and 198 on the antenna bottom surface. The signal is fed to or received

from the antenna 170 through the feed contact 200 on the bottom surface of the antenna 170.

The patterned conductive feed plate 188 is formed preferably by etching conductive material from the outer surface of the dielectric layer 184. The antenna  
5 170 further includes two vias 206 and 208. The via 206 is electrically connected to the feed plate. The via 208 is conductively isolated from the feed plate 188 by an intervening gap 210, but is electromagnetically coupled to the feed plate 188 due to the proximity to the conductive material of the feed plate 188.

The top plate 186 is electrically connected to a continuous conductive strip  
10 212 extending along the front surface of the dielectric layer 184 above an upper edge 214 of the feed plate 188. Due to the proximity between the conductive strip 212 and the feed plate 188, there exists electromagnetic coupling between these two elements.

The rear surface of the antenna 170 is illustrated in Figure 11, including the patterned ground plate 190 disposed on the outwardly facing surface of the dielectric  
15 layer 180. The via 208 is conductively connected to the ground plate 190, and the via 206 is electromagnetically coupled thereto. The ground plate 190 is also electrically connected to the top plate along an edge 215 where these two elements contact. Note a cut-out region 218 of the ground plate 190 avoids electrical contact between the ground plate 190 and the feed contact 200 extending along the bottom surface of the  
20 antenna 170.

Although specifically-shaped feed and ground plates 188 and 190, respectively, are shown in Figures 10 and 11, it is known by those skilled in the art that other geometric shapes will also produce desired antenna operational characteristics.

The ground contacts 196 and 198 and the feed contact 200 are located on the  
25 bottom surface as also shown in the bottom view of Figure 12. The ground contacts 196 and 198 are conductively connected to the antenna ground plate 190 and the feed contact 200 is conductively connected to the feed plate 188. Advantageously, the antenna can be placed (by known pick and place assembly machines) onto a patterned  
30 printed circuit board, such as the printed circuit board 154 of Figure 9, such that the ground contacts 196 and 198 and the feed contact 200 mate with the appropriate

traces on the board 154 and then the antenna 170 is soldered into place by a solder reflow or wave solder operation.

Exemplary conductive patterns for patterned surfaces 190 and 191 are shown in Figure 13. On the surface 191, the via 206 is surrounded by and electrically  
5 connected to a pad 224, which in turn is electrically connected to a continuous conductive strip 226. The conductive strip 226 provides electrical connection between the via 206 and the surrounding pad 224, to the top plate 186. The via 208 simply passes through the dielectric layer 184.

The details of the patterned surface 190 are illustrated in Figure 14. The via  
10 206 passes therethrough, while the via 208 is connected to a pad 230 that is in turn connected to a conductive strip 232 formed (preferably by etching away conductive material) along the top edge of the patterned surface 190. The conductive strip 232 also provides an electrical connection to the top plate 186. In addition to the conductive connection between the vias 206 and 208 and the top plate 186, both are  
15 electromagnetically coupled to the top plate 186 since they are located proximate thereto.

The meanderlines of the low profile dielectrically loaded meanderline antenna  
170 are non-symmetric because the only electrical connection from the feed plate 188 to the top plate 186 is by way of the via 206. Whereas the ground plate is connected  
20 both directly to the top plate 186 along the line 214 and further connected to the top plate 186 through the via 208.

Figure 15 is an exploded view of the three dielectric layers 180, 182 and 184, and indicates the location of the patterned surfaces 190 and 191, the feed plate 188 and the ground plate 190.

Fabrication of the antenna 170 employs conventional masking, patterning and  
25 etching process after which the dielectric layers 180, 182 and 184 are laminated together. Further details of the process are set forth in the patent application referenced below. Automated pick and place machines place the antenna 170 on the printed circuit board 154. A reflow soldering process electrically connects the ground  
30 and feed contacts to the appropriate traces on the board.

One embodiment of the antenna 170 is approximately 0.2 inches deep, 0.6 inches wide and 0.18 inches high. This antenna operates at a center frequency of

approximately 5.25 GHz with a bandwidth of approximately 200 MHz. The bandwidth and center frequency can be adjusted by changing the distance between the vias 206 and 208 and/or changing the distance between the top plate 186 and each of the vias 206 and 208. This embodiment of the antenna 170 radiates a vertically polarized signal.

Figure 16 illustrates a low profile dielectrically loaded meanderline antenna 240 suitable for use as either or both of the antennas 149 and 150 of Figure 9. The antenna 240 is similar to the antenna 170 of Figure 10, absent the vias 206 and 208 and having different conductive patterns on the interior surfaces of the three dielectric layers 180, 182 and 184. Also, the patterned conductive feed plate 188 is replaced by a feed plate 242 having a different conductive pattern thereon.

Further details of the a low profile dielectrically loaded meanderline antennas 170 and 240 can be found in commonly-owned patent application number 10/160,930 filed on May 31, 2002 and entitled A Low Profile Dielectrically Loaded Meanderline Antenna, which is hereby incorporated by reference.

Figure 16 illustrates a radiation pattern diversity and signal polarization diversity system where an antenna 250 has a highly linearly polarized pattern toward the zenith. For example, one embodiment of the antenna 250 comprises the antenna 170 of Figure 10. An antenna 252 comprises a monopole antenna producing a donut radiation pattern with the axis of the donut perpendicular to a printed circuit board 254, on which both the antennas 250 and 252 are mounted. Thus the combined radiation patterns produces a hemispherical coverage pattern, and this embodiment is referred to as a switched hemispherical radiation pattern diversity antenna. Since the individual patterns minimally overlap, the combination provides a larger overall antenna pattern. This embodiment is recommended for applications where the communications system requires a high antenna gain over a hemispherical or spherical area. Additional antenna elements, such as the antennas 12 and 14 of Figure 1 or the antenna 76 of Figure 3 can be added to the embodiment of Figure 16 or used in lieu of the antennas 250 and 252, to provide signal polarization diversity within the pattern diversity.

In the Figure 16 embodiment, the printed circuit board 254 carries a ground plane. The operative antenna of the antennas 250 and 252 is selected by the control circuitry 22 according to predetermined signal metrics as described above.

5 Thus according to the present invention a plurality of antennas are employed at a receiving or transmitting station to provide signal polarization, spatial and/or radiation pattern diversity. The operative antenna is selected to maximize a signal quality metric (or minimize the metric depending on the selected metric).

10 Although the various embodiments presented herein preferably operate in a switched diversity mode, in another embodiment, both antennas can be simultaneously operative to receive or send a signals such that the composite signal, due to the combination of the radiation patterns and/or signal polarizations, has the desired characteristics.

## WHAT IS CLAIMED IS:

1. An antenna system comprising at least two antennas for providing diversity operation, the antenna system comprising:

5 a first antenna having first signal polarization and first radiation pattern characteristics; and

a second antenna having second signal polarization and second radiation pattern characteristics different from the first signal polarization and the first radiation pattern characteristics.

10 2. The antenna system of claim 1 wherein the first signal polarization characteristic is selected from among vertical signal polarization, horizontal signal polarization and circular signal polarization.

3. The antenna system of claim 1 wherein the first radiation pattern characteristic is selected from among an omnidirectional pattern, an elevation pattern and an isotropic pattern.

15 4. The antenna system of claim 1 wherein the first and the second antennas are mounted on a planar structure, and wherein the first and the second antennas are connected to a common ground plane disposed on the planar structure.

5. The antenna system of claim 4 wherein the planar structure comprises a printed circuit board.

20 6. The antenna system of claim 1 wherein the first and the second antennas are spaced apart to provide spatial diversity.

7. The antenna system of claim 1 further comprising a controller wherein the controller determines whether the first antenna or the second antenna is operative in response to a measured signal quality metric.

25 8. The antenna system of claim 7 wherein both the first antenna and the second antenna are operative in response to the measured signal quality metric.

9. The antenna system of claim 1 wherein the first and the second antennas are operative in a wireless local area network.

30 10. An antenna system comprising at least two antennas for providing diversity operation, the antenna system comprising:

a first antenna having a first signal polarization characteristic;

a second antenna having second signal polarization characteristic different from the first signal polarization characteristic;

a controller for selecting the operative antenna from between the first antenna and the second antenna based on a provided signal quality metric; and

5 wherein the first and the second antenna are mounted on a planar structure having a ground plane disposed thereon, and wherein the first and the second antennas are connected to the ground plane.

11. The antenna system of claim 10 wherein the first and the second antennas are spaced apart to provide spatial diversity.

10 12. An antenna system comprising at least two antennas for providing diversity operation, the antenna system comprising:

a first antenna having a first radiation pattern characteristic;

a second antenna having second radiation pattern characteristic different from the first radiation pattern characteristic;

15 a controller for selecting the operative antenna from between the first antenna and the second antenna based on a provided signal quality metric; and

wherein the first and the second antenna are mounted on a planar structure having a ground plane disposed thereon, and wherein the first and the second antennas are connected to the ground plane.

20 13. The antenna system of claim 12 wherein the first and the second antennas are spaced apart to provide spatial diversity.

14. An antenna system comprising at least two antennas for providing diversity operation, the antenna system comprising:

a first antenna;

25 a second antenna oriented with respect to the first antenna to provide one or both of signal polarization diversity and radiation pattern diversity with respect to the first antenna;

a controller for selecting the operative antenna from between the first antenna and the second antenna based on a provided signal quality metric;

30 wherein the first and the second antennas are mounted on a planar structure, and wherein the first and the second antennas are connected to a common ground plane disposed on the planar structure.

15. The antenna system of claim 14 wherein the first and the second antennas are spaced apart to provide spatial diversity.

16. The antenna system of claim 15 wherein the first and the second antennas are spaced apart by a fraction of the operational wavelength to provide spatial diversity.

17. A antenna system comprising a plurality of antennas for providing diversity operation, the antenna system comprising:

a first pair of antennas having different signal polarization characteristics;

a second pair of antennas having different radiation pattern characteristics;

a controller responsive to both the first and the second pairs of antennas for determining the operative antenna from the first pair of antennas and for determining the operative antenna from the second pair of antennas in response to a measured signal quality metric.

18. The antenna system of claim 17 further comprising a third pair of antennas in a spaced-apart orientation for providing spatial diversity.

19. The antenna system of claim 17 wherein the antennas of the first pair of antennas and the antennas of the second pair of antennas are spaced apart to provide spatial diversity operation.

20. An antenna system providing selectable antenna performance characteristics, comprising:

a plurality of radiation pattern diverse antennas each having a gain and a radiation pattern characteristic; and

a controller for selecting, in response to a signal quality metric, an antenna having the desired gain with the desired antenna pattern from among the plurality of antennas.

21. The antenna system of claim 20 wherein the plurality of antennas are spaced apart to provide spatial diversity.

22. The antenna system of claim 21 wherein the plurality of antennas have different signal polarization characteristics.

23. For operation in a wireless local area network communications system, an antenna system comprising:



a first antenna having first signal polarization characteristics and first radiation pattern characteristics;

a second antenna having second signal polarization characteristics and second radiation pattern characteristics;

5            wherein the first and the second antennas are mounted on a common substrate;  
a determined signal quality metric; and

a controller for selecting the operative antenna from between the first antenna and the second antenna in response to signal quality metric.

10           24.    The antenna system of claim 23 wherein the common substrate comprises a ground plane to which the first and the second antennas are electrically connected.

25.    The antenna system of claim 23 wherein the first and the second antennas are spaced apart a distance determined by the operational wavelength.

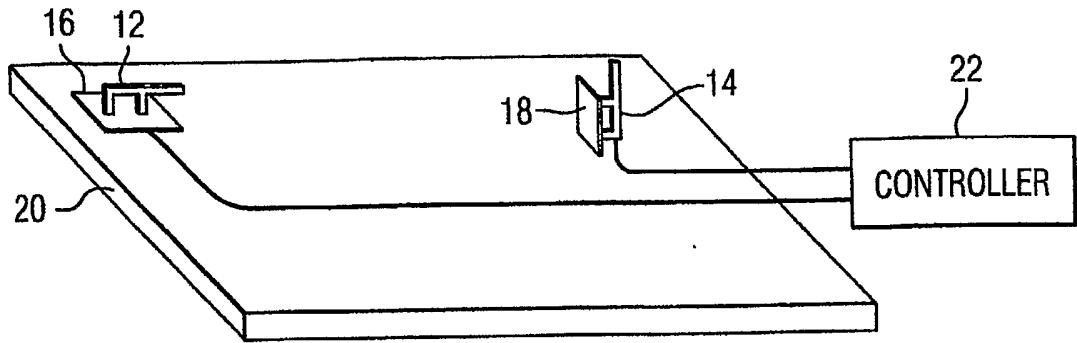


FIG. 1

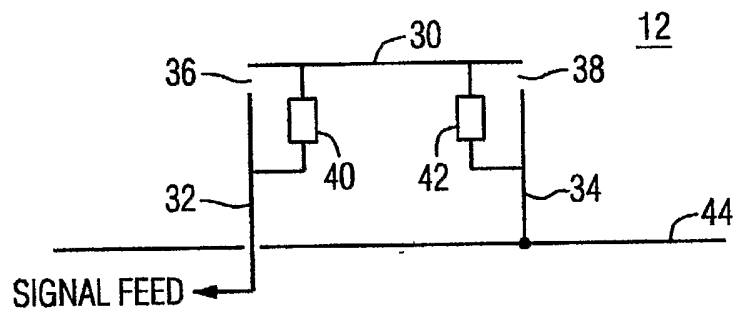


FIG. 2

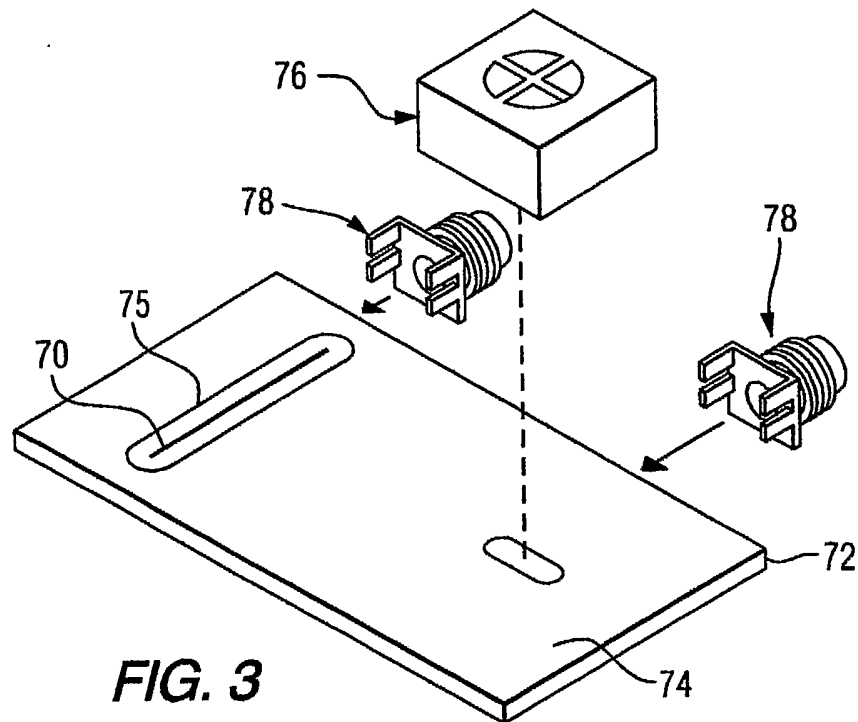
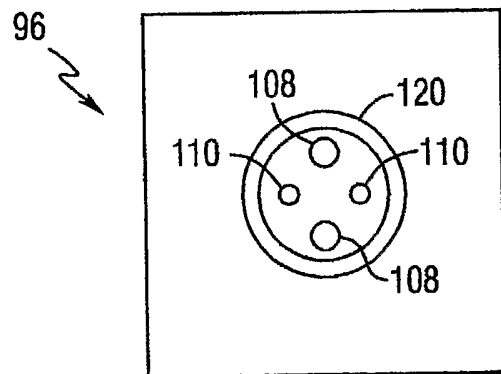
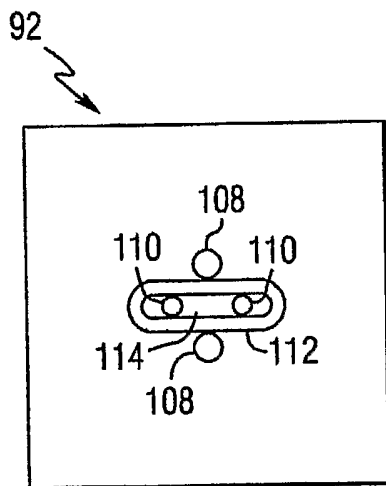
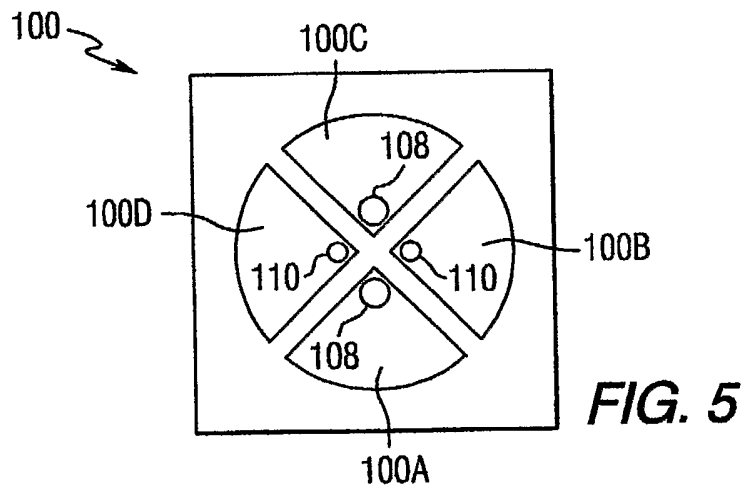
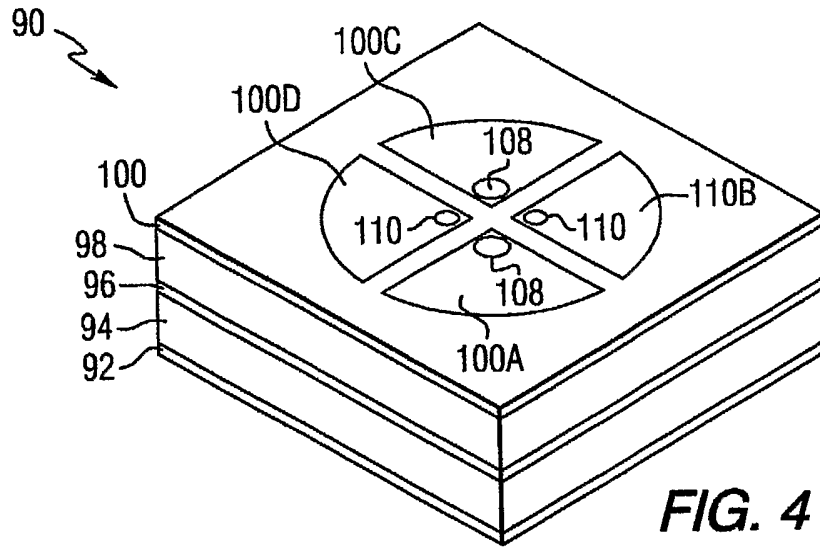
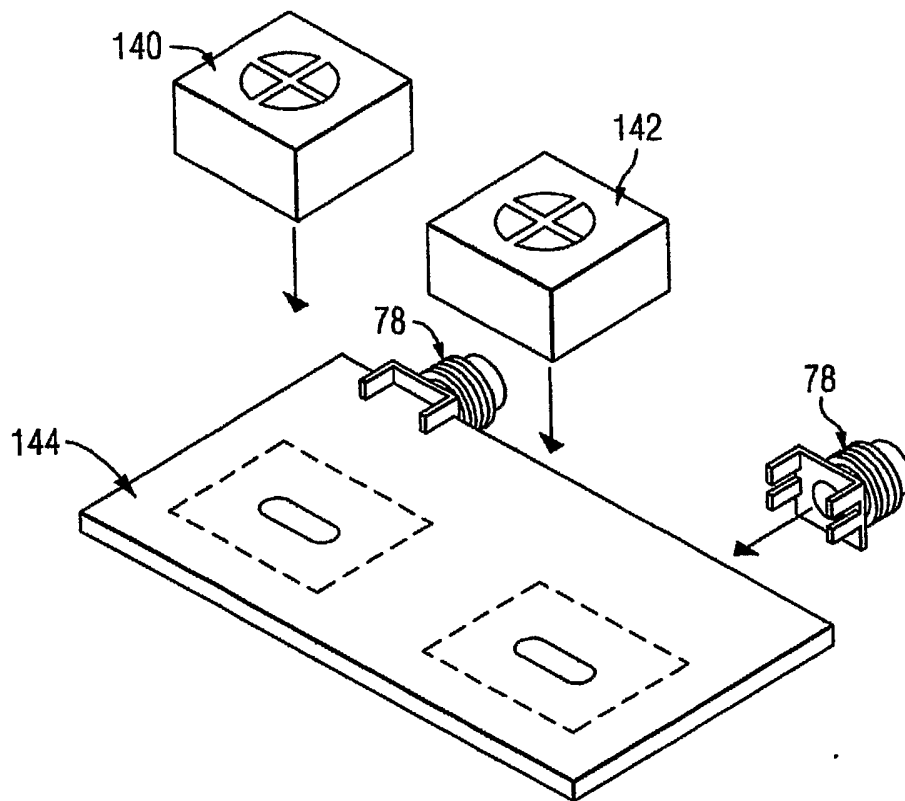
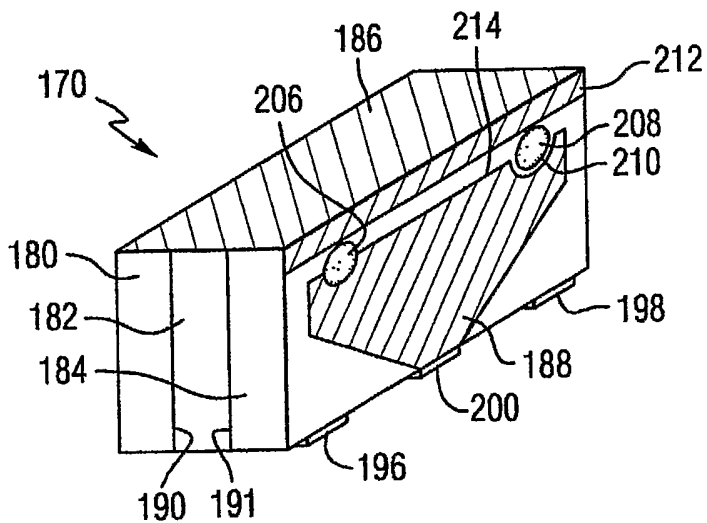


FIG. 3

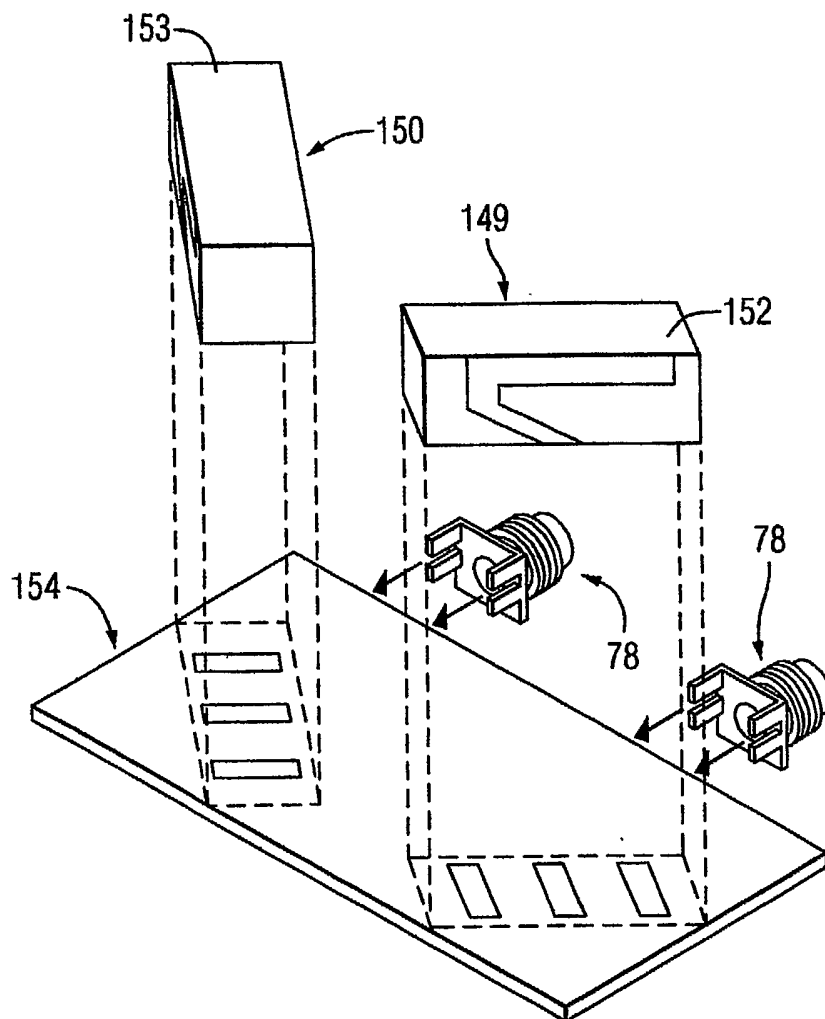




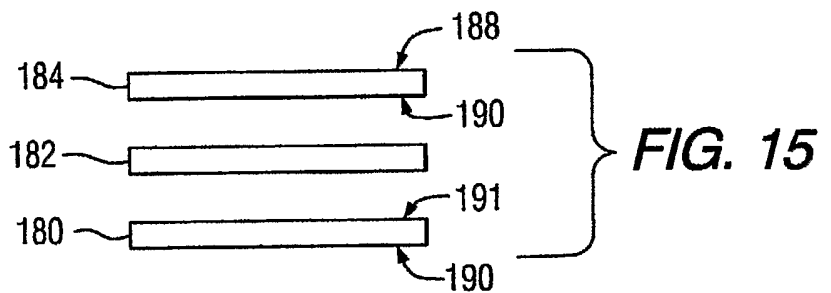
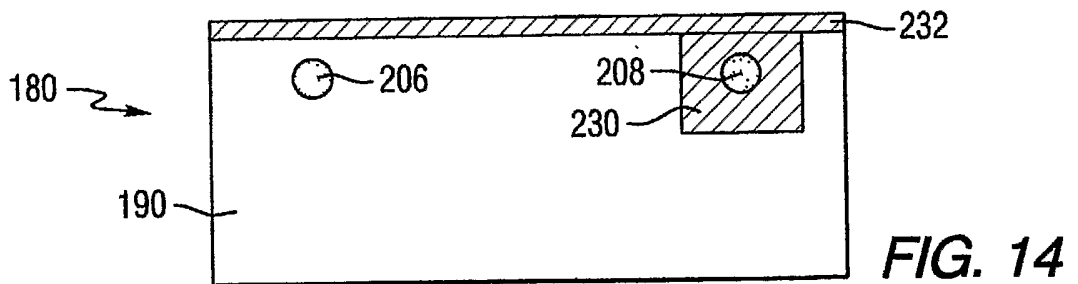
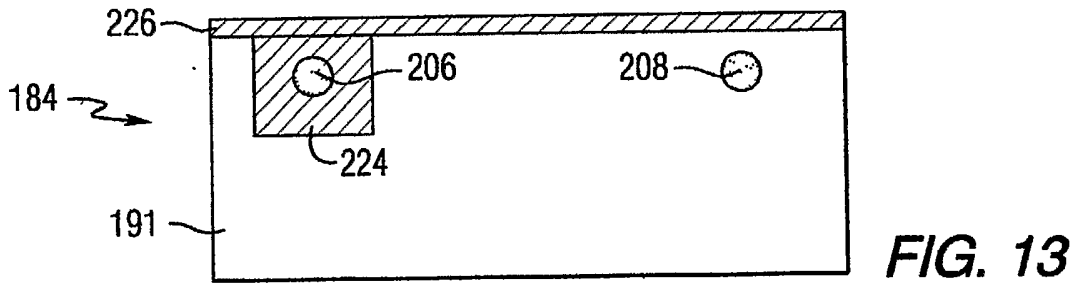
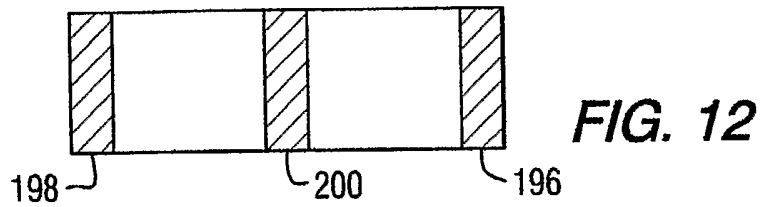
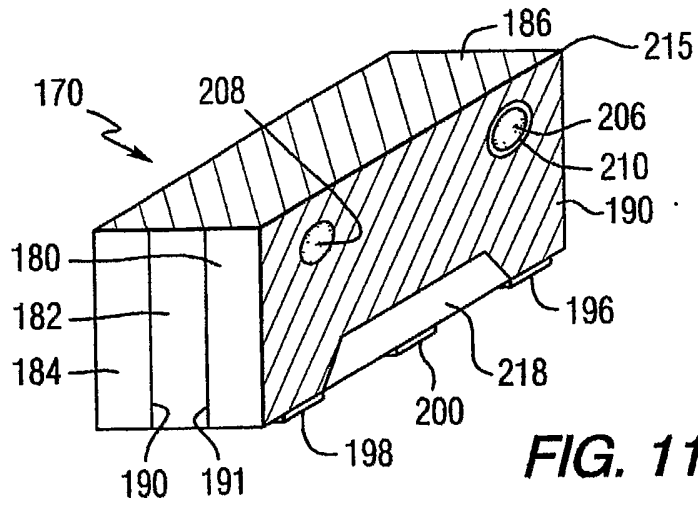
**FIG. 8**

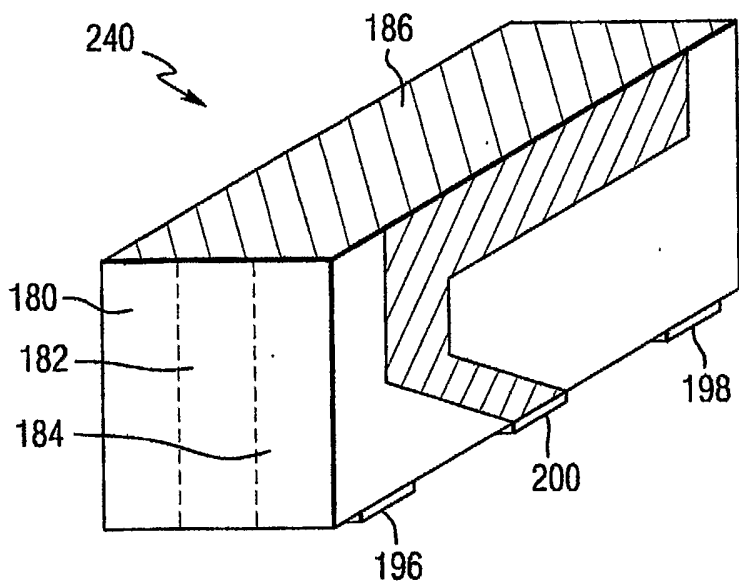


**FIG. 10**

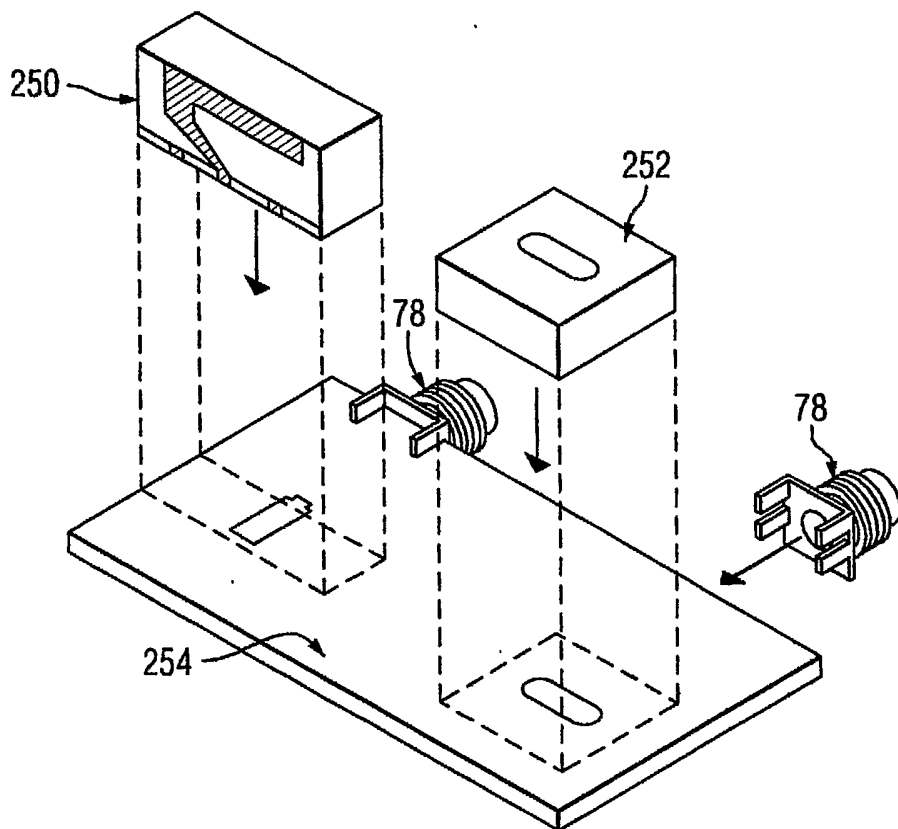


**FIG. 9**





**FIG. 16**



**FIG. 17**

INTERNATIONAL SEARCH REPORT

International application No.  
PCT/US02/38866

A. CLASSIFICATION OF SUBJECT MATTER

IPC(7) :H01Q 21/00, 21/10  
US CL :343/700MS, 730, 794, 799, 813, 827, 829, 853, 872, 893  
According to International Patent Classification (IPC) or to both national classification and IPC

B. FIELDS SEARCHED

Minimum documentation searched (classification system followed by classification symbols)  
U.S. : 343/700MS, 730, 794, 799, 813, 827, 829, 853, 872, 893

Documentation searched other than minimum documentation to the extent that such documents are included in the fields searched  
NONE

Electronic data base consulted during the international search (name of data base and, where practicable, search terms used)  
USPTO APS EAST

C. DOCUMENTS CONSIDERED TO BE RELEVANT

Category*	Citation of document, with indication, where appropriate, of the relevant passages	Relevant to claim No.
X --- A	US 5,486,836 A (KUFFNER et al) 23 January 1996 (23.01.1996), Figure. 36; column 2.	1-6, 9 ----- 7, 8, 10-25
X --- A	US 5,880,695 A (BROWN et al) 09 March 1999 (09.03.1999), Figure 1; columns 3-4.	1-3, 9 ----- 4-8, 10-25
X,P --- A,P	US 6,320,544 B1 (KORISCH et al) 20 November 2001 (20.11.2001), Figures 1-3; columns 2, 3, 5.	1-5, 9 ----- 6-8, 10-25
X,P --- A,P	US 6,429,820 B1 (THURSBY et al) 06 August 2002 (06.08.2002), Figures 16-17; column 9.	1-5, 9 ----- 6-8, 10-25
A	US 5,926,137 A (NEALY) 20 July 1999 (20.07.1999), Figures 1A,	1-25

Further documents are listed in the continuation of Box C.  See patent family annex.

* Special categories of cited documents:	"T" later document published after the international filing date or priority date and not in conflict with the application but cited to understand the principle or theory underlying the invention
"A" document defining the general state of the art which is not considered to be of particular relevance	"X" document of particular relevance; the claimed invention cannot be considered novel or cannot be considered to involve an inventive step when the document is taken alone
"E" earlier document published on or after the international filing date	"Y" document of particular relevance; the claimed invention cannot be considered to involve an inventive step when the document is combined with one or more other such documents, such combination being obvious to a person skilled in the art
"L" document which may throw doubts on priority claim(s) or which is cited to establish the publication date of another citation or other special reason (as specified)	"&" document member of the same patent family
"O" document referring to an oral disclosure, use, exhibition or other means	
"P" document published prior to the international filing date but later than the priority date claimed	

Date of the actual completion of the international search 07 FEBRUARY 2003	Date of mailing of the international search report <b>03 APR 2003</b>
---	--

Name and mailing address of the ISA/US  
Commissioner of Patents and Trademarks  
Box PCT  
Washington, D.C. 20231  
Facsimile No. (703) 305-3230

Authorized officer  
TRINH VO DINH  
Telephone No. (703) 305-4525





## INTERNATIONAL SEARCH REPORT

International application No.  
PCT/US02/38866

## C (Continuation). DOCUMENTS CONSIDERED TO BE RELEVANT

Category*	Citation of document, with indication, where appropriate, of the relevant passages	Relevant to claim No.
A	US 6,023,244 A (SNYGG et al) 08 February 2000 (08.02.2000), whole document.	1-25
A	US 6,057,802 A (NEALY et al) 02 May 2000 (02.05.2000), whole document.	1-25
A	US 6,300,906 B1 (RAWNICK et al) 09 October 2001 (09.10.2001), Figures 1-2.	1-25
A	GB 2 067 842 A (COLIN et al) 30 July 1981 (30.07.1981), Figure 1.	1-25
X	US 5,923,296 A (SANZGIRI et al) 13 July 1999 (13.07.1999), Figure 2; column 3.	1-6, 9
---		-----
A		7, 8, 10-25