

F. F. VAN EPS.
 GEM GRINDER AND POLISHER.
 APPLICATION FILED SEPT. 14, 1909.

962,274.

Patented June 21, 1910.

2 SHEETS—SHEET 1.

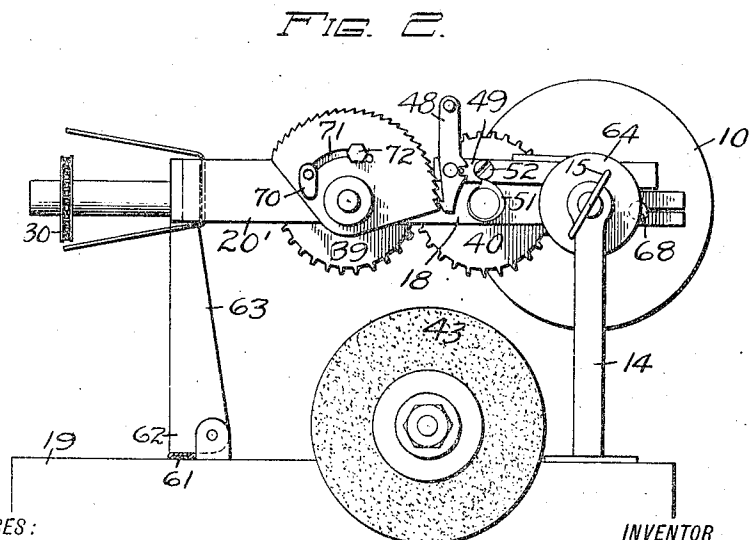
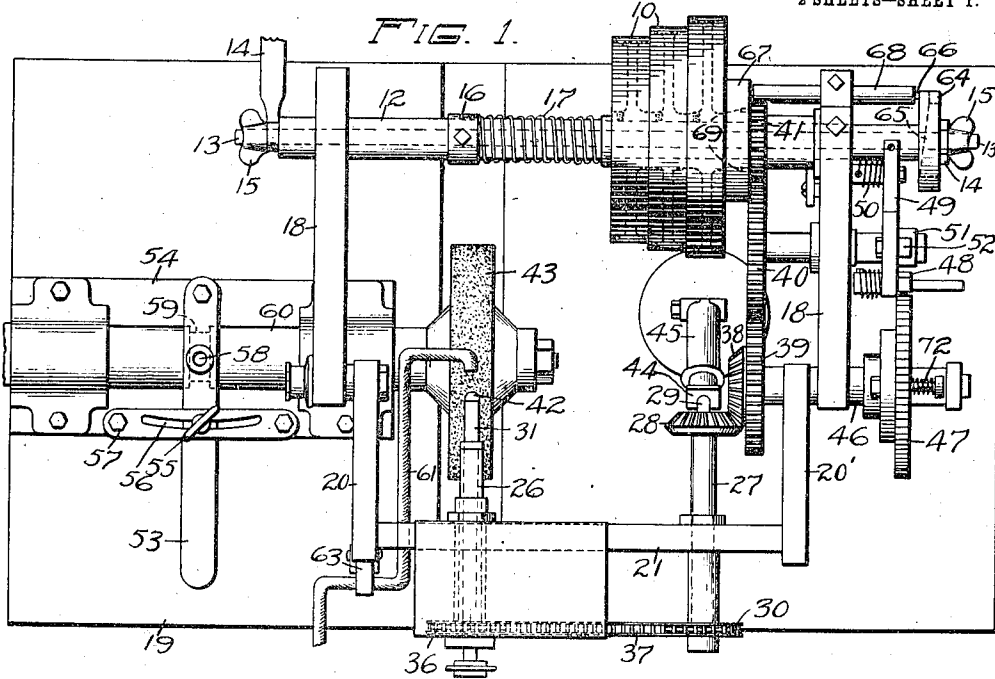

WITNESSES:
 Geo. A. Senior
 Wm Smith

INVENTOR
 Fred F. Van Eps.
 BY
 Victor J. Evans
 ATTORNEY

F. F. VAN EPS,
 GEM GRINDER AND POLISHER,
 APPLICATION FILED SEPT. 14, 1909.

962,274.

Patented June 21, 1910.

2 SHEETS—SHEET 2.

FIG. 3.

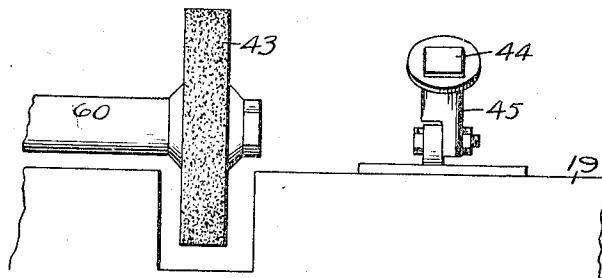
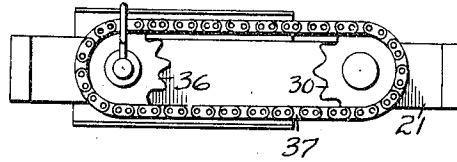

FIG. 4.

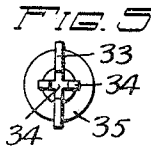
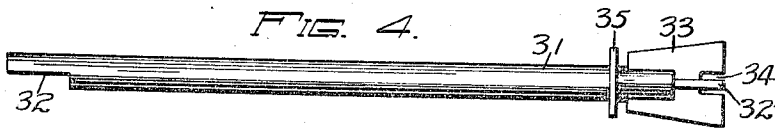

FIG. 6.

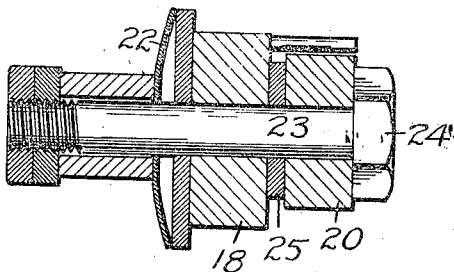
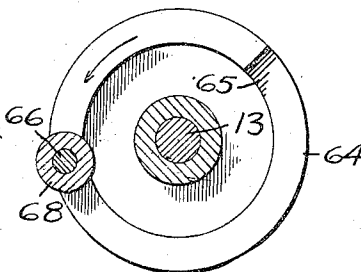

FIG. 7.



WITNESSES:
 Geo. A. Senior
 Wm Smith

INVENTOR,
 Fred F. Van Eps,
 BY
 Victor J. Evans
 ATTORNEY

UNITED STATES PATENT OFFICE.

FRED F. VAN EPS, OF NORTH PLAINFIELD, NEW JERSEY.

GEM GRINDER AND POLISHER.

962,274.

Specification of Letters Patent. Patented June 21, 1910.

Application filed September 14, 1909. Serial No. 517,700.

To all whom it may concern:

Be it known that I, FRED F. VAN EPS, a citizen of the United States, residing at North Plainfield, in the county of Somerset and State of New Jersey, have invented new and useful Improvements in Gem Grinders and Polishers, of which the following is a specification.

This invention relates to grinders and polishers for gems and more especially to semi-precious stones, and its object is to provide means for holding the gem against a polishing wheel and automatically shifting and turning the stone to shape it in accordance with an original form or model which controls the position of the gem against the wheel, as will be more fully explained in the following specification, set forth in the claims and illustrated in the drawings, where:

Figure 1 represents a plan view of the device. Fig. 2 is an end view showing the frame work and gem moved away from the cutting wheel. Fig. 3 is a front view of the spindle carrying frame, and showing it raised away from the grinding wheel and the bearing plate for the former. Fig. 4 is a view of the gem holding stick. Fig. 5 is an end view of same. Fig. 6 is a view of the pivot of the spindle carrying frame. Fig. 7 is a sectional view showing the shifting cam for stopping train of wheels.

The pulleys 10 which furnish the motive force for the device are secured to a sleeve 67 which is mounted and turns freely on a tube 12 having through its center a rod 13 supported by brackets 14, threaded at its outer ends and provided with thumb nuts 15 which jam against the brackets and hold the rod rigidly. Between one end of the sleeve and a collar 16 is a spring 17 which forces sleeve 67 in the opposite direction and against the gear 69 that revolves on tube 12. The arms 18 and tube 12 are adapted to be swung around the rod but normally occupy an acute angle from the base 19. At the outer end of the arms 18 is a frame comprising arms 20 and 20' and a cross piece 21, one of the arms at its pivotal point being provided with friction means shown in Fig. 6 and which consists of a dished spring 22 centered on the pivot bolt 23 and exerting a tension on the head 24 so as to bind the arm 20 against a washer 25 so that it is retained at any angle when once fixed, but is free to move with the least exertion.

The cross piece 21 carries the spindles 26 and 27, the latter having beveled gear 28 and the model head 29 while at its outer end is a sprocket wheel 30. The spindle 29 carries the gem holding stick 31 which is cut away as at 32 at its rear end to engage a shoulder on the interior of the spindle to prevent its rotation therein while its outer end carries the blades 32' and the forward end has the blades 33 arranged at right angles to each other and having central recesses 34 to more effectually hold the cement which retains the gem at the end of the stick. It is obvious that these sticks have blades of different sizes to conform with the outlines of the gem to serve as a means for cementing stone in proper position on the stick, the shapes shown in Figs. 4 and 5 being for a gem with oval outlines. The outer end of the stick is also provided with a collar 35 which limits the movement of the stick within the spindle and firmly holds it against the pressure exerted on the gem while the rear end of the spindle is provided with a sprocket wheel 36 that is connected with the wheel 30 by means of the chain 37 so that the two spindles will move in unison. The rotation of the spindle is effected by means of the beveled gear 38 driven by the gear wheels 39, both of which are carried by a stud from the arm 18, and the gear wheels 40 and 41 which latter are connected with the pulleys 10 and mounted on the sleeve 67.

The object of the machine is to treat the gem 42 over its exposed surface and to do this it is necessary to give the ends of the spindles 26 and 27 a movement of about 90° which will bring the exposed surfaces of the gem 42 and the former 29 against their bearing surface, the bearing surface for the gem being the emery wheel 43 while the former bears against an adjustable hard metal plate 44, whose face is an arc identical with the edge of the wheel 43, carried in an arm 45 which is fastened to the base 19. The action to effect this operation is accomplished by the 90° movement of the spindle carrying frame on its pivotal points and the operation commences with frame 20 at right angles with arms 18 (and top of gem against cutting wheel) and moves gradually by means of pawl 48 and ratchet 47 to a position 90° from starting point (with edge of stone against cutting wheel) and the arm 20' is carried by the sleeve 46 journaled at the outer end of the adjacent arm 18 and at

one end of this sleeve is the said ratchet segment 47. The pawl 48 is carried at the lower end of a lever 49 pivoted near the upper end of the arm 18 and having a spring 50 to retain it in its normal position. The lever is rocked by means of a cam 51 at the outer end of the shaft of the gear wheel 40 and as will be seen in Fig. 2 this cam plays upon a roller 52 at one side of the arm 49 at each rotation of the wheel 40 and in oscillating the arm it causes the pawl to advance the ratchet segment 47 and change the position of the former and gem. It will thus be seen that while the gem and former are being rotated by the movement of their spindles, the position of the gem and former are being changed by means of the segment 47 and as the shape of the gem is to be identical with the former 29, the bearing of the latter upon the plate 44 controls the contact of the gem with the emery wheel 43 so that the shape of the two will be identical and the action of the wheel is limited to a shape identical with the former.

In order to grind on any part of the emery wheel, it may be shifted by means of a lever 53 which is pivoted at one side of the bearing 54 and has a thumb screw 55 near its outer end which plays in the slot 56 of a plate 57 so that the lever may be shifted and held at any desired point. Depending from the lever is a pin 58 carrying a roller which plays in a groove 59 in the shaft 60 of the emery wheel and while this shaft is being rotated from any convenient source such as belt and pulleys it may be shifted longitudinally so as to bring any part of the face of the emery wheel to operate upon the gem.

In order to cool the gem and prevent its destruction a jet of water is supplied by means of a rubber pipe 61 connected with any suitable water supply and secured to the base adjacent to the heel 62 of an arm 63 which is used to hold the spindle carrying frame in its horizontal position as shown in Fig. 2 and when this arm is elevated rendering the device inoperative, the heel is pressed down upon the rubber tube thus shutting off the water supply. In order to shut off the power, the rod 13 has at one end of the wheel 64 fitting on its inner face, the cam surface 65 and against which bears a pin 66 whose other end rests against the hub 67 of the pulleys. The pin is carried by a sleeve 68 clamped to the rear end of one of the arms 18 and when the arm 18 which carries the pin is swung upward, the pin bears against cam face and is thrust backward forcing the hub away from the gear wheel 41 and causing the pin 69 on latter to disengage itself from sockets in the hub 67.

It will thus be seen that this device furnishes a simple and perfect cutter and polisher for the gem whose movement is automatic. The action of the ratchet segment 47

may be adjusted by a shifting plate 70 which reduces the length of the slot 71 and the consequent traveling of a pin 72 therein. Ratchet segment 47 works idly until pin 72 reaches end of slot 71 thus allowing time for top of stone to be ground to size or thickness before the spindle carrying frame commences its movement.

It is obvious that the details of this machine and the arrangement of its parts may be varied without departing from the essential features above described and at the same time be within a scope of the appended claims.

What I claim as new and desire to secure by Letters Patent is:

1. In a grinder and polisher, the combination with a grinding wheel, of a rotating gem holder, a model holder rotating simultaneously with the gem holder, means for rotating the holders separately, means for automatically shifting the angle of the holders so as to present the surface of the stone to the grinding wheel that it may be cut to correspond with the model.

2. In a grinder and polisher, the combination with a rotating grinding and polishing wheel, of a former or model, a rotating carrier for same, a simultaneously rotating gem carrier, means for rotating the carriers separately, and means for presenting the gem to the face of the wheel to correspond with the shape of the former.

3. In a grinder and polisher, the combination with a rotating grinding and polishing wheel, of a frame, a rotating spindle for the gem holder, a rotating spindle for the former, means for simultaneously and separately rotating the two spindles, and means for changing the angle of the spindles.

4. In a grinder and polisher, for gems, the combination with a rotating grinding and polishing wheel, of a spindle to carry the gem, a former, rotating sleeves for the gem and former spindles carrying the gem holder and former and adapted to work in unison, means for rotating the spindles and means for automatically moving the spindles radially.

5. In a gem grinder and polisher, the combination with a grinding and polishing wheel, of a rod supported by brackets, a sleeve on the rod, arms carried by the sleeve, a gem carrier, a former, and means for simultaneously rotating the carrier and former.

6. In a gem grinder and polisher, the combination with a grinding and polishing wheel, of a rod carried by uprights, a sleeve mounted on the rod, a gear wheel loosely mounted on the sleeve, a rotating gem holder, a rotating former, and means connected with the gear wheel for driving the gem holder and former.

7. In a grinder and polisher for gems, the

combination with a grinding and polishing wheel, of a rod mounted in uprights, a sleeve on the rod, arms carried by the sleeve, pulleys and a gear wheel on the sleeve, a frame pivoted at the ends of the arms, a gem holder and a former carried by the frame and adapted to rotate in same, and means driven by the gearing for simultaneously rotating the former and gem holder.

8. In a gem grinding and polishing machine, the combination with a grinding and polishing wheel mounted in a base, of a rod carried by uprights, a sleeve loosely fitted about the rod, arms on the sleeve, a frame carried at the ends of the arms, a correspondingly operated gem holder and former carried by the frame, pulleys and gear wheel loosely mounted on the sleeve and adapted to rotate the gem holder and the former, and means for automatically turning the frame on its pivots.

9. In a gem grinder and polisher, the combination with a grinding and polishing wheel mounted on a base, brackets on the base, a rod rigidly carried in the brackets, a sleeve on the rod, arms on the sleeve, a frame pivoted in the ends of the arms, spindles carrying the gem and a former, a plate arising from the base to control the former, means for causing the former and gem spindles to work in unison, pulleys on the sleeve, gearing means connected with the same for rotating the spindles, a ratchet wheel on the pivot of the frame and a pawl operated by one of the gear wheels to shift the ratchet wheel.

10. In a gem grinder and polisher, the combination with a grinding and polishing wheel, of a base carrying the same, uprights on the base, a rigid rod carried by the up-

rights, a sleeve on the rod, arms on the sleeve, a frame supported at the ends of the arms, friction means at the end of one of the arms and on the pivot of the frame, a ratchet at the pivot of the other arm to shift the frame, a spindle for holding the gem, a spindle for carrying the former, a plate regulating the play of the former, pulleys and a gear wheel loosely mounted on the sleeve beveled gear on spindle of the former, gearing interposed between the gear wheel on the sleeve and the beveled pinion on the spindle and carried by one of the arms, a pawl to engage the ratchet, a lever carrying the pawl, a cam connected with the shaft of one of the gear wheels to oscillate the lever, a cam carried by the rod, a pin carried by the adjacent arm and adapted to be thrust longitudinally by the cam when the arm is swung upward so as to disconnect the pulleys, a flexible water supply pipe for the polishing wheel and a lever pivoted to the base and adapted to support the frame when swung upward and at the same time to cut off the water supply.

11. In a gem grinder and polisher, the combination with a longitudinally shifting grinding wheel, of means for shifting the shaft of same, uprights, a rod secured in same, a sleeve, arms on the sleeve, spindles, a pivoted spindle carrying frame at the ends of the arms, and driving means on the sleeve to rotate the spindles and adapted to shift the frame on its pivots.

In testimony whereof I affix my signature in presence of two witnesses.

FRED F. VAN EPS.

Witnesses:

JAMES F. DUHAMEL,
CHARLES LA RUE.