

(No Model.)

G. W. BAKER.

BORING TOOL.

No. 293,397.

Patented Feb. 12, 1884.

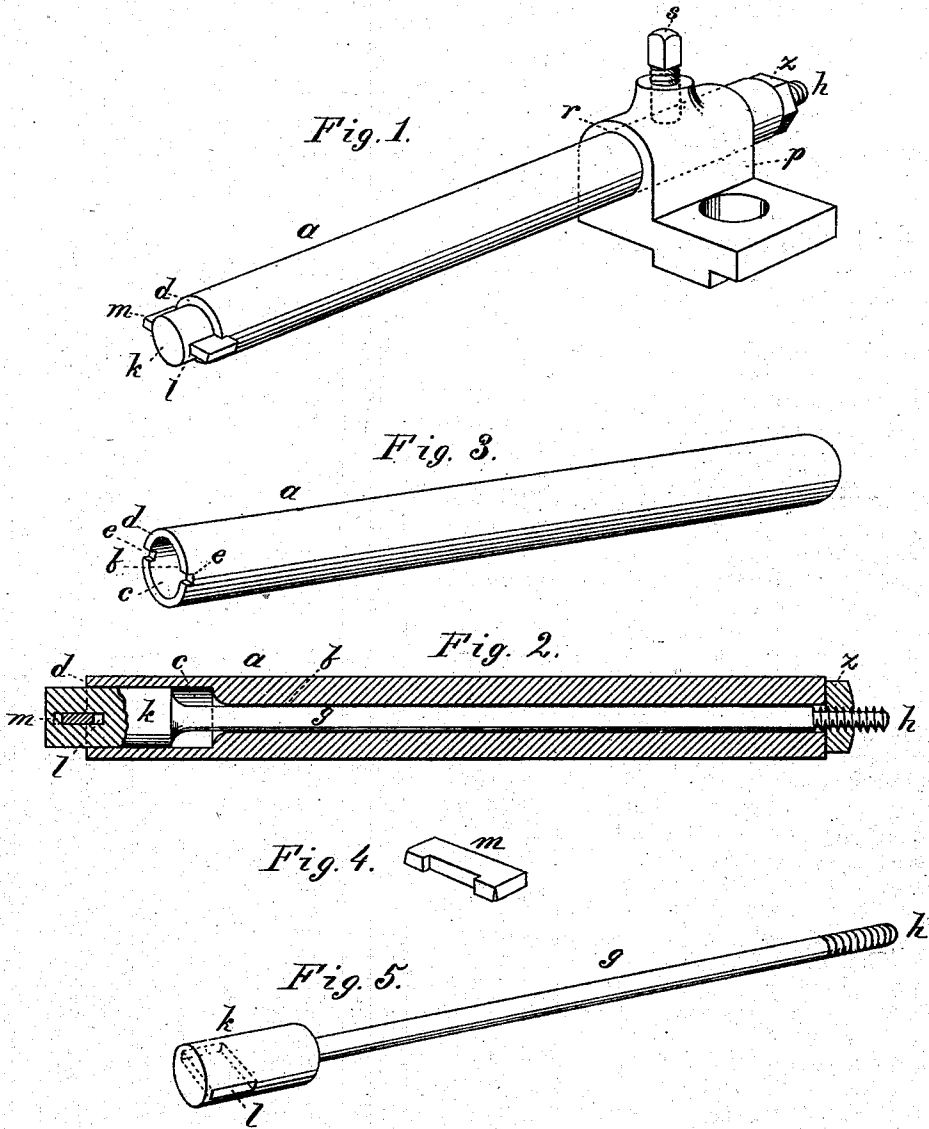

WITNESSES
Villette Anderson.
Emory B. Bates.

INVENTOR
G. W. Baker
By Audison Smith
his ATTORNEYS

UNITED STATES PATENT OFFICE.

GEORGE W. BAKER, OF WILMINGTON, DELAWARE.

BORING-TOOL.

SPECIFICATION forming part of Letters Patent No. 293,397, dated February 12, 1884.

Application filed June 23, 1883. (No model.)

To all whom it may concern:

Be it known that I, G. W. BAKER, a citizen of the United States, residing at Wilmington, in the county of New Castle and State of Delaware, have invented certain new and useful Improvements in Boring-Tools; and I do hereby declare the following to be a full, clear, and exact description of the invention, such as will enable others skilled in the art to which it appertains to make and use the same, reference being had to the accompanying drawings, and to letters or figures of reference marked thereon, which form a part of this specification.

Figure 1 of the drawings is a representation of this invention and is a perspective view. Fig. 2 is a longitudinal section. Fig. 3 is a detail, showing the sleeve in perspective. Figs. 4 and 5 are details, showing the cutter-holder and cutter in perspective.

This invention has relation to lathe attachments; and it consists in the construction and novel arrangement of an axially-hollow sleeve having an enlargement of its bore near one end and opposite notches in the rim or end of said enlargement, and a cutter-holding stem having the enlarged and slotted end fitting in the enlargement of the bore of the sleeve, the opposite threaded end projecting beyond the end of the sleeve, and the fastening-nut, whereby the cutter is held in engagement with the rim-notches of the sleeve, all as hereinafter set forth.

In the accompanying drawings, the letter *a* designates a metallic sleeve, preferably made of steel, and having an axial bore, *b*, which is enlarged at one end, as at *c*, forming a chamber having a rim, *d*, which is notched at opposite points *e*. Extending through the bore of the sleeve is the steel cutter-holding stem or shank *g*, which is threaded at one end, as at *h*, and is formed at the opposite end with an enlargement, *k*, of proper diameter to fit neatly within the end-chamber of the bore of the sleeve. Through the enlargement *k* extends a transverse slot, *l*, of sufficient size to permit the passage of a transverse cutter, *m*,

the lateral wings or cutting portions whereof project from the sides of the enlargement. On the threaded end *h* of the stem is provided a nut, *z*, which is designed to be turned up against the outer end of the sleeve, drawing the stem through the sleeve sufficiently to cause the wings of the cutter to become firmly engaged with the notches of the sleeve end. In this manner the cutter is firmly secured to the sleeve.

P represents a holding-block, designed to be fastened to the slide-rest. It is provided with a socket, *r*, through which the boring-bar is passed, being adjustable therein to project more or less, according to requirement. A set-screw, *s*, extending through a threaded perforation in the top of the socket, serves to hold the boring-bar rigidly in position after adjustment.

In making the boring-bars for mills, it may be preferable to use a slot and tapering key at the outer end, instead of the thread and nut. By either fastening, the cutter is drawn to its bearing in the notched rim of the sleeve in a perfectly-true manner, and is held firmly and securely.

Having described this invention, what I claim, and desire to secure by Letters Patent, is—

The combination of the adjustable sleeve *a*, having the forward end of its axial bore enlarged, and provided with diametrically-arranged notches *e e*, the cutter *m*, and the stem *g*, having the enlargement *k*, to fit within the enlargement of the sleeve-bore, and provided with a transverse slot, *l*, to receive the cutter *m*, the wings of which fit over the notches *e*, and provided at its opposite end with a thread to receive the lock-nut *z*, substantially as specified.

In testimony whereof I affix my signature in presence of two witnesses.

GEORGE W. BAKER.

Witnesses:

MAURICE P. SATTERTHWAITE,
WM. W. PRITCHETT.