

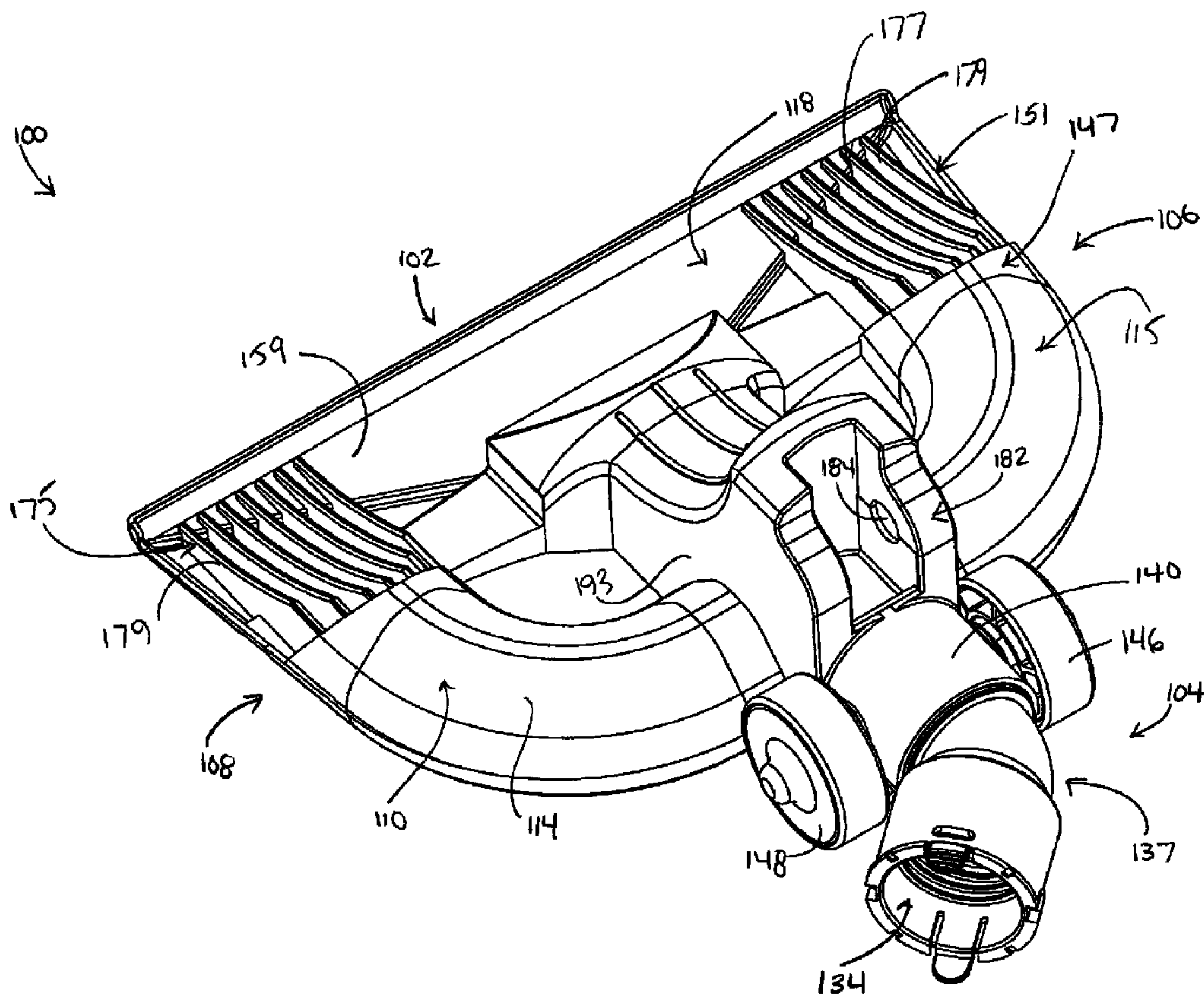

(22) Date de dépôt/Filing Date: 2009/03/13  
(41) Mise à la disp. pub./Open to Public Insp.: 2010/09/13

(51) Cl.Int./Int.Cl. *A47L 9/02* (2006.01),  
*A47L 5/24* (2006.01), *A47L 9/00* (2006.01)  
(71) Demandeur/Applicant:  
G.B.D. CORP., BS  
(72) Inventeur/Inventor:  
CONRAD, WAYNE ERNEST, CA  
(74) Agent: BERESKIN & PARR LLP/S.E.N.C.R.L.,S.R.L.

(54) Titre : TETE DE NETTOYAGE DE SURFACES  
(54) Title: SURFACE CLEANING HEAD



(57) Abrégé/Abstract:  
A surface cleaning head comprises an upper section and a lower section. A front portion of the upper section extends forwardly of the lower section. At least a section of the front portion is transparent.

## ABSTRACT

A surface cleaning head comprises an upper section and a lower section. A front portion of the upper section extends forwardly of the lower section. At least a  
5 section of the front portion is transparent.

**TITLE: SURFACE CLEANING HEAD****FIELD**

[0001] The specification relates to surface cleaning heads. Preferably, the specification relates to surface cleaning heads for surface cleaning apparatuses  
5 such as vacuum cleaners wherein a transparent front portion is provided.

**INTRODUCTION**

[0002] The following is not an admission that anything discussed below is prior art or part of the common general knowledge of persons skilled in the art.

[0003] U.S. Patent 4,395,794 discloses a vacuum cleaner intake device  
10 formed of a V-shaped housing widening in the direction of working. The housing has a funnel shape nozzle, a fitting at the apex of the nozzle for connection to a source of suction and a pair of arms extending in a V-shape respectively forwardly and laterally of the nozzle. A pair of sidewalls are provided each having a skid at its lower edge elevating the housing above the floor. A hood covers and  
15 defines with the arms and the side walls a collection chamber open at the forward and rear edges. Each of the arms are provided on their bottom surface with a pair of spaced battens defining between them an elongated suction groove open to the collection chamber and extending outwardly through the side wall.

**SUMMARY**

20 [0004] The following introduction is provided to introduce the reader to the more detailed discussion to follow. The introduction is not intended to limit or define the claims.

[0005] According to one broad aspect, a surface cleaning head is provided. The surface cleaning head comprises a front end and a rear end.  
25 An air flow passage extends from a dirty air inlet to an air outlet. The surface cleaning head further comprises an upper section and a lower section. A front

portion of the upper section extends forwardly of the lower section. At least a section of the front portion is transparent.

[0006] In some examples, the front portion is transparent. In some examples, the upper portion is transparent.

5 [0007] In some examples, the surface cleaning head has an outer surface, and an outer surface of the upper section and an outer surface of the lower section comprise essentially all of the outer surface of the surface cleaning head.

[0008] In some examples, the surface cleaning head has a clam shell construction wherein the upper section and the lower section comprise the clam  
10 shell.

[0009] In some examples, the dirty air inlet is at the front end, and at least a portion of the airflow passage extends under the section of the front portion that is transparent. The portion of the airflow passage may comprise an open lower sided airflow chamber. The airflow passage may comprise at least a section that  
15 has an open lower side.

[0010] In some examples, the airflow passage includes an enclosed passage and an enclosed passage inlet, and the surface cleaning head further comprises front wheels. The front wheels may be positioned rearward of the enclosed passage inlet. The front wheels may be positioned under the lower  
20 section.

[0011] In some examples, lower section is opaque.

[0012] In some examples, the upper section has an upward facing portion and the upper section further comprises reinforcing ribs.

[0013] In some examples, the upper section comprises a rear portion, a  
25 transition portion and the front portion, the rear portion has a higher height than the front portion and the transition portion extends downwardly to the front portion.



[0014] In some examples, the front portion comprises a single layer of plastic. The front portion may have a thickness less than 0.1 inch.

[0015] It will be appreciated that a surface cleaning head may incorporate one or more of the features of each of these embodiments and examples.

## 5 DRAWINGS

[0016] Figure 1 is a top perspective view of an embodiment of a surface cleaning head;

[0017] Figure 2 is a side plan view of the surface cleaning head of Figure 1;

10 [0018] Figure 3 is a bottom plan view of the surface cleaning head of Figure 1;

[0019] Figure 4 is a bottom perspective view of the surface cleaning head of Figure 1;

15 [0020] Figure 5 is an exploded view of the surface cleaning head of Figure 1;

[0021] Figure 6 is a front perspective view of a surface cleaning apparatus comprising the surface cleaning head of Figure 1;

[0022] Figure 7 is a cross-section taken along line 7-7 in Figure 3;

[0023] Figure 8 is a cross-section taken along line 8-8 in Figure 3; and

20 [0024] Figure 9 is a cross-section taken along line 9-9 in Figure 3.

## DESCRIPTION OF VARIOUS EMBODIMENTS

[0025] Various apparatuses or methods will be described below to provide an example of each claimed invention. No example described below limits any claimed invention and any claimed invention may cover processes or apparatuses that are not described below. The claimed inventions are not limited to apparatuses or processes having all of the features of any one apparatus or

25

process described below or to features common to multiple or all of the apparatuses described below. It is possible that an apparatus or process described below is not an embodiment of any claimed invention.

5 [0026] Referring to Figures 1-5 and 7-9, an example of a surface cleaning head 100 is shown. Referring to Figure 6, as will be described further hereinbelow, the surface cleaning head 100 is connectable in air flow communication to a surface cleaning apparatus 600, such as a vacuum cleaner (e.g., a canister or an upright vacuum cleaner), and preferably, an upright vacuum cleaner.

10 [0027] Referring to Figures 1 to 3, the surface cleaning head 100 comprises a front end 102, and a rear end 104. The surface cleaning head further comprises first 106 and second 108 opposed lateral sides. A top outer surface 110 and a bottom outer surface 112 each extend between the front end 102 and the rear end 104, and the opposed lateral sides 106, 108. In the  
15 exemplified embodiment, the top 110 and bottom 112 outer surfaces form essentially all of the outer surface 101 of the surface cleaning head. It will be appreciated that the surface cleaning head 100 may be of any shape and preferably has a front 102 that is straight. In the exemplified embodiment, the top 110 and bottom 112 outer surfaces form essentially all of the outer surface 101 of  
20 the surface cleaning head.

[0028] It will be appreciated that the surface cleaning head 100 may be constructed from any number of parts. A simplified construction that may be used is exemplified. In the exemplified embodiment, a clam shell construction is utilized whereby a lower open sided air chamber is formed by having a portion of  
25 the top member of the clam shell extend forward of the lower clam shell portion. This construction may be used by itself or with other features of a surface cleaning head set out herein. Preferably, as exemplified, the surface cleaning head 100 comprises an upper section 114, and a lower section 116. The upper section 114 has an outer surface 115, and the lower section 116 has an outer



surface 117. The outer surfaces 115, 117 are defined as surfaces that are visible when the surface cleaning head 100 is assembled. Preferably, as in the exemplified embodiment, upper section 114 is an integrally formed plate, and lower section 116 is an integrally formed plate.

5 [0029] The front portion 118 of the upper section 114 extends forwardly of the lower section 116. Preferably, front portion defines a lower open sided air flow chamber.

[0030] As exemplified, at front portion 118 of the upper section 114, the outer surface 115 has an upward facing portion 159, and a downward facing  
10 portion 161. The downward facing portion 161 forms a front portion 120 of bottom surface 112. Further the outer surface 117 of the lower section 116 forms a rear portion 121 of the bottom surface 112.

[0031] Preferably, the front portion 118 of the upper section 114 comprises a single layer of material. For example, the front portion 118 of the upper section  
15 114 may comprise a single layer of plastic. In some embodiments, the plastic may have a thickness less than 0.1 inches.

[0032] In the exemplified embodiment, reinforcing ribs 179 are provided on the upward facing portion 159 of the outer surface 115 of upper section 114. The reinforcing ribs 179 may prevent front portion 118 from breaking or deflecting  
20 when surface cleaning head 100 is in use, for example if front portion 118 hits a wall. In the embodiment shown, a first set of reinforcing ribs 177 is provided adjacent the first lateral side 106, and a second set 175 of reinforcing ribs is provided adjacent the second lateral side 108. Preferably, the reinforcing ribs are integrally molded with upper section 114.

25 [0033] The reinforcing ribs 179 extend upwardly and rearwardly from the front end 102, and increase in height going rearwardly. The ribs 179 merge with a rear portion 147 of the upper section 114, which is at a higher height than the

front portion. Accordingly, in the exemplified embodiment, the ribs are at a transition portion 151 of the upper section 114.

[0034] In the exemplified embodiment, the outer surface 115 of the upper section 114, and the outer surface 117 of the lower section 116 comprise essentially all of the outer surface of the surface cleaning head. That is, the outer surface 115 of the upper section 114, and the outer surface 117 of the lower section 116 comprise all of the outer surface of the surface cleaning head, excluding an optional pivot mount cover 193, as will be described hereinbelow. In alternate embodiments, other sections (e.g. other plates) may be provided, which may form portions of the outer surface of the surface cleaning head 100.

[0035] Preferably, at least a section of the front portion 118 is transparent. For example, the transparent section may be fabricated from a transparent plastic, such as polycarbonate. More preferably, all of the front portion 118 is transparent. For example, in the exemplified embodiment, all of upper section 114 is transparent, including all of front portion 118. Preferably, the lower section 116 is opaque. It will be appreciated that upper section 114 may be tinted.

[0036] The surface cleaning apparatus comprises an airflow passage extending from a dirty air inlet 130 to an air outlet 134. Preferably, at least a portion of the airflow passage extends under the section of the front portion 118 that is transparent. More preferably, the airflow passage comprises at least a section that has an open lower side.

[0037] For example, as shown, the dirty air inlet 130 is provided at front end 102. A first airflow chamber 128 extends rearwardly from dirty air inlet 130. In the exemplified embodiment, the airflow chamber 128 is integrally formed in front portion 118 of upper section 114. More particularly, the outer surface 115 of the upper section is contoured to form a top wall 190, and opposed side walls 192, 194, of the airflow chamber 128. Accordingly, the airflow chamber 128



extends under front portion 118, and as all of front portion 118 is transparent, the airflow chamber 128 provides the portion of the airflow passage that extends under the transparent section of front portion 118.

5 [0038] In the exemplified embodiment, all of the lower side 188 of the airflow chamber, which extends between the air inlet 130, the rear 132, and the sides 192, 194, is open. In alternate embodiments, only a portion may be open. Any lower open sided construction may be used.

10 [0039] An advantage of using an integrally formed upper section 114 is that front portion 118 may be transparent and may have sufficient strength to permit the front of the cleaning head to comprise a single layer of plastic. If an open sided air flow chamber is provided below front portion 118, which is preferred, then a user may view the air channel and determine if a blockage occurs.

15 [0040] An advantage of the transition region is that reinforcing ribs may be provided to provide rigidity to front portion 118. During use, front portion 118 may vibrate or flex, particularly at high suction. This may affect the efficiency of the vacuum cleaner due to variations in air flow rate in the lower open sided air flow chamber.

20 [0041] Rear end 132 of airflow chamber 128 may be in communication with a manifold 198, which is in communication with an enclosed passage 140 via an enclosed passage inlet 136. The enclosed passage 140 extends rearwardly from the enclosed passage inlet 136. A swivel joint 137 is mounted to a rear end of the enclosed passage 140, and is in airflow communication with the enclosed passage 140. The swivel joint is mountable in airflow communication  
25 with the surface cleaning apparatus 600, and comprises the air outlet 134 of the surface cleaning head 100. Any other connection known in the vacuum cleaner arts may be used.

[0042] Preferably, as in the exemplified embodiment, the surface cleaning apparatus further comprises a second airflow chamber 122, and a third airflow chamber 123, which form a portion of the airflow passage. The second airflow chamber has an inlet 124 at first lateral side 106, and an outlet 126 in communication with manifold 198. The third airflow chamber 123 has an inlet 125 at second lateral side 108, and an outlet 127 in communication with manifold 198. Inlets 124 and 125 form auxiliary dirty air inlets to surface cleaning head 100. Both the second 122 and third 123 airflow chambers are preferably integrally formed in front portion 118 of upper section 114. For example, the outer surface 115 of the upper section 114 may be contoured to form a top wall 133, and opposed side walls 135, 139 of the second airflow chamber 122, and to form a top wall 141 and opposed side walls 143, 145 of the third airflow chamber 123. In the exemplified embodiment, the second airflow chamber 122 has an open lower side 129, and the third airflow chamber 123 has an open lower side 131. In another embodiment, inlets 124, 125 may not be provided.

[0043] The surface cleaning head 100 is preferably configured to transition from a low pile carpet to a high pile carpet. This design may be used by itself or with any other feature disclosed herein. For example, as shown, the front portion 118 of top section 114 comprises an upwardly curved lip 199. Lip 199 is provided at the front 102 of the surface cleaning head 100, above dirty air inlet 130. Accordingly, if surface cleaning head 100 is pushed from a low pile carpet to a high pile carpet, lip 199 will serve as a ramp, and aid in lifting the surface cleaning head 100 from the low pile carpet onto the high pile carpet.

[0044] In some embodiments, the sidewalls 192, 194 of the first airflow passage are formed from triangular members 167 and 169. The triangular members 167, 169 may curve upwardly together with lip 199 at front end 102. This is shown in Figure 7. The front or leading edge of any side wall for the open lower sided air flow channel may be chamfered, curved or radiused.



[0045] In some embodiments, ribs that act as carpet holders may be provided, which, in use, hold down a carpet, and prevent the carpet from being lifted upward off of a surface by the flow of air through the open sided airflow passages 128, 122, 123. This design may be used by itself with an lower open sided air flow chamber or with any other feature disclosed herein. For example, as shown in Figure 8, two carpet holders 195 are provided, which extend downwardly from top wall 190 of first passage 128 and preferably extend in a direction of flow.

[0046] Referring to Figures 2 to 5, the surface cleaning head 100 preferably comprises at least front wheels. In the exemplified embodiment, the surface cleaning head 100 comprises first 142 and second 144 front wheel assemblies, and first 146 and second 148 rear wheels. Preferably, the front wheel assemblies 142, 144 are rotatable about vertical axes. More preferably, the front wheel assemblies 142, 144 are rotatable about vertical axes, and comprise wheels that are rotatable about horizontal axes. The front wheels may be swivel, caster or ball wheels. This configuration of wheels may be used by itself or with any other feature disclosed herein.

[0047] For example, in the exemplified embodiment, the first front wheel assembly 142 comprises a first front wheel 150, and second front wheel 144 assembly comprises a second wheel front 152. The first front wheel assembly 142 further comprises a first bracket 154, having outwardly extending arms 156a, 156b. The first front wheel 150 is mounted on a first axle 158, which extends horizontally between the arms 156a, 156b. Accordingly, the first front wheel 150 is rotatable about a horizontal axis H1 defined by first axle 158. The second front wheel assembly 144 further comprises a second bracket 160, having outwardly extending arms 162a, 162b. The second front wheel 152 is mounted on a second axle 164 which extends horizontally between the arms 162a, 162b. Accordingly, the second front wheel 152 is rotatable about a horizontal axis H2 defined by axle 164.



[0048] As exemplified, the first bracket 154 comprises a first vertically extending portion 166 provided above the outwardly extending arms 156, and the second bracket 160 comprises a second vertically extending portion 168 provided above the outwardly extending arms 162. First 170 and second 172 vertical pins are mounted to the lower section 116, and extend downwardly therefrom. The first vertically extending portion 166 is rotatably received on the first pin 170, and the second vertically extending portion 168 is rotatably received on the second pin 172. Accordingly, the first 154 and second 160 brackets are rotatable about first and second vertical pins 170 and 172, respectively, to rotate first 142 and second 144 front wheel assemblies about vertical axes V1 and V2, respectively.

[0049] Preferably, as shown in Figure 4, the horizontal axis of rotation H1 of the first front wheel 150 is spaced from the vertical axis of rotation V1 of the first front wheel assembly 142, and the horizontal axis of rotation H2 of the second front wheel 152 is spaced from the vertical axis of rotation V1 of the first front wheel assembly 144. For example, as exemplified, outwardly extending arms 156a, 156b extend laterally away from vertically extending portion 166, such that axle 158, which defines axis H1, is spaced from vertically extending portion 166, which defines axis V1. Similarly, outwardly extending arms 162a, 162b extend laterally away from vertically extending portion 168, such that axle 164, which defines axis H2, is spaced from vertically extending portion 168, which defines axis V2.

[0050] Preferably, as shown in Figure 4, the rear wheels 146, 148 are rotatable about horizontal axes H3. For example, as shown in Figure 5, the rear wheels 146, 148 are mounted on axles 174 and 176, respectively, which are fixedly mounted on opposed sides of enclosed passage 140, adjacent rear end 104.

[0051] Preferably, as exemplified the front wheels are positioned rearwardly of the enclosed passage inlet 136.

[0052] Preferably, the rear wheels 146, 148 are positioned closer together than the front wheel assemblies 142, 144. For example, in the exemplified embodiment, the front wheel assemblies 142, 144 are positioned adjacent lateral sides 106, 108, respectively of the surface cleaning head 100. Further, as  
5 mentioned hereinabove, the rear wheels 146, 148 are positioned on opposed sides of enclosed passage 140.

[0053] Preferably, the front wheels are positioned under the lower section 116. For example, as shown, the front wheels are mounted to the outer surface 117 of the lower section 116. More preferably, a portion of each front wheel  
10 assembly 142, 144, is recessed upwards from the bottom surface 112 of the surface cleaning head 100. For example as shown in Figures 3 and 4, a first recess 178 and a second recess 180 are provided in lower section 116, and extend upwardly. The first front wheel assembly 142 is mounted in the first  
15 recess 178, such that bracket 154 is completely received within the first recess 178, and a portion of wheel 150 extends from the first recess 178. The second front wheel assembly 144 is mounted in the second recess 180, such that bracket 160 is completely received within the first recess 180, and a portion of wheel 152 extends from the second recess 180. As shown in Figure 3, this allows bottom surface 112 to sit in close proximity to a floor F.

20 [0054] Preferably, the front wheels 150, 152 have a smaller diameter than the rear wheels 146, 148.

[0055] Referring to Figure 1, surface cleaning head 100 may further comprise a pivot joint 182, which is mounted to upper section 114, and is covered by a cover 193. The pivot joint 182 comprises laterally opposed  
25 apertures 184 (only one aperture shown). The pivot joint 182 is positioned between the front wheel assemblies 142, 144 and the rear wheels 146, 148. As shown in Figure 6, a support 606 of the surface cleaning apparatus 600 is pivotally mounted to the pivot joint 182 by a pivot pins 605a, 605b.



[0056] Referring now to Figure 6, a surface cleaning apparatus 600 comprising surface cleaning head 100 is shown. It will be appreciated that surface cleaning head 100 may be mounted to any suitable surface cleaning apparatus, and surface cleaning apparatus 600 is exemplary only.

5 [0057] Preferably, as in the embodiment shown, surface cleaning apparatus 600 comprises a flexible hose 602, which is mounted to swivel joint 137 and is in fluid communication with air outlet 134. However, a rigid conduit may also be used. Hose 602 extends upwardly to a cleaning unit 604. The  
10 cleaning unit 604 is mounted to support 606, which is pivotally mounted to pivot joint 182 of surface cleaning head 100. The cleaning unit 604 includes a cleaning apparatus 608. The cleaning apparatus 608 is in fluid communication with hose 602, and serves to separate dirt from air. The cleaning apparatus 608 may be any type of cleaning apparatus, such as one or more cyclonic cleaning units, and/or one or more filters. The cleaning unit further comprises a suction  
15 motor 610, which draws air into the dirty air inlets of surface cleaning head, through surface cleaning head 100 to outlet 134, through hose 602, through cleaning apparatus 608, and out of a clean air outlet 612 of the surface cleaning apparatus 600. A handle 614 is mounted to cleaning unit 604, and may be gripped by a user to move surface cleaning head 100 along a surface.

20



## CLAIMS:

1. A surface cleaning head comprising:
  - (a) a front end and a rear end;
  - 5 (b) an air flow passage extending from a dirty air inlet to an air outlet; and,
  - (c) an upper section and a lower section, a front portion of the upper section extends forwardly of the lower section
 wherein at least a section of the front portion is transparent.
- 10 2. The surface cleaning head of claim 1 wherein the front portion is transparent.
3. The surface cleaning head of any of claims 1-2 wherein the upper portion is transparent.
- 15 4. The surface cleaning head of any of claims 1-3 wherein the surface cleaning head has an outer surface and an outer surface of the upper section and an outer surface of the lower section comprise essentially all of the outer surface of the surface cleaning head.
- 20 5. The surface cleaning head of any of claims 1-4 the surface cleaning head has a clam shell construction wherein the upper section and the lower section comprise the clam shell.
- 25 6. The surface cleaning head of any of claims 1-5 wherein the dirty air inlet is at the front end and at least a portion of the airflow passage extends under the section of the front portion that is transparent.
7. The surface cleaning head of claim 6 wherein the portion of the airflow passage comprises an open lower sided airflow chamber.

8. The surface cleaning head of any of claims 1-6 wherein the airflow passage comprises at least a section that has an open lower side.
- 5 9. The surface cleaning head of any of claims 1-8 wherein the airflow passage includes an enclosed passage and an enclosed passage inlet and the surface cleaning head further comprises front wheels wherein the front wheels are positioned rearward of the enclosed passage inlet.
- 10 10. The surface cleaning head of any of claims 1-8 further comprising front wheels wherein the front wheels are positioned under the lower section.
11. The surface cleaning head of any of claims 1-10 wherein the lower section is opaque.
- 15 12. The surface cleaning head of any of claims 1-11 wherein the upper section has an upward facing portion and the upper section further comprises reinforcing ribs provided on the upward facing portion.
- 20 13. The surface cleaning head claim 12 wherein the upper section comprises a rear portion, a transition portion and the front portion, the rear portion has a higher height than the front portion and the transition portion extends downwardly to the front portion.
- 25 14. The surface cleaning head of any of claims 12-13 wherein the front portion comprises a single layer of plastic.
15. The surface cleaning head of any of claims 11-14 wherein the front portion has a thickness less than 0.1 inch.

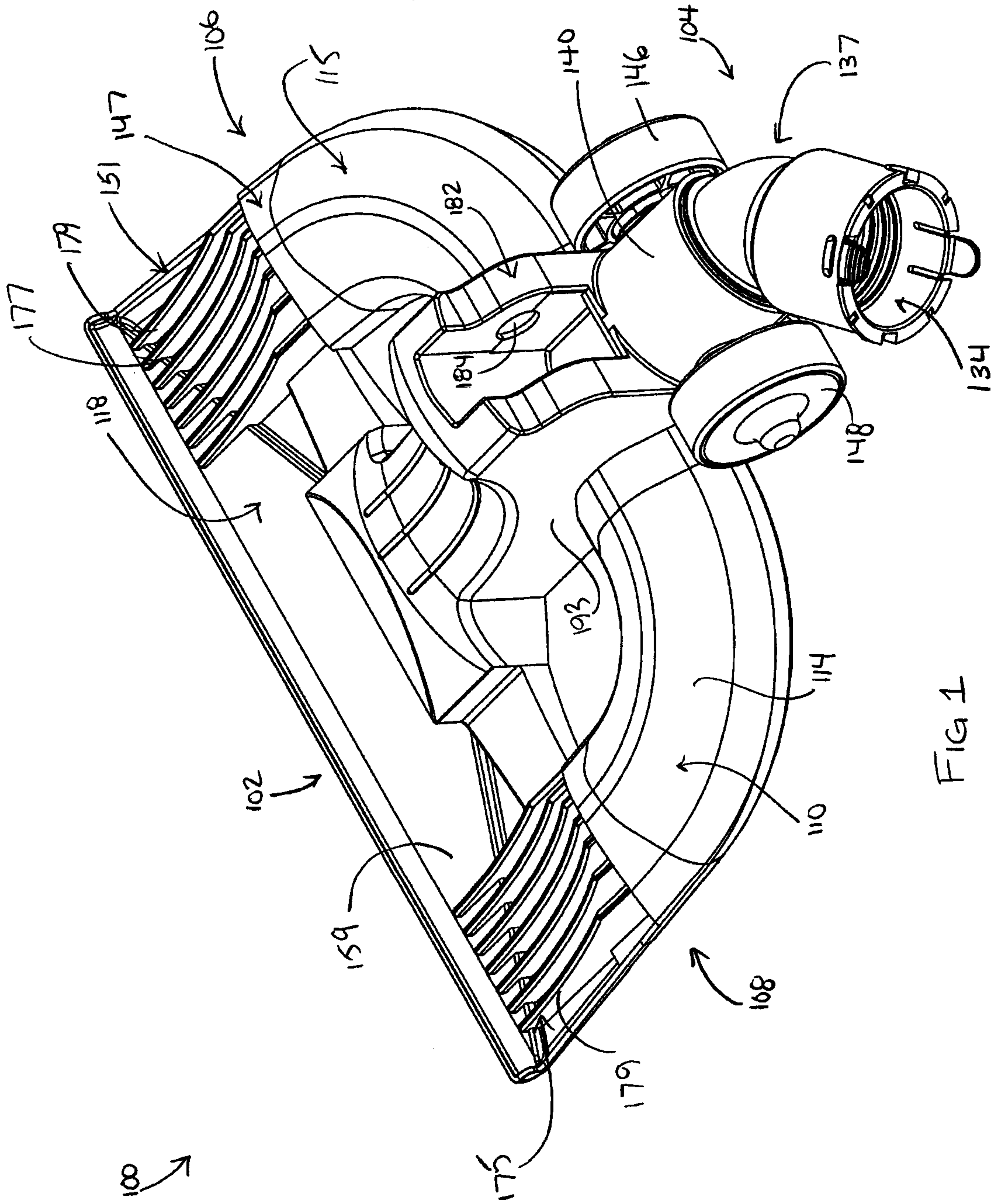
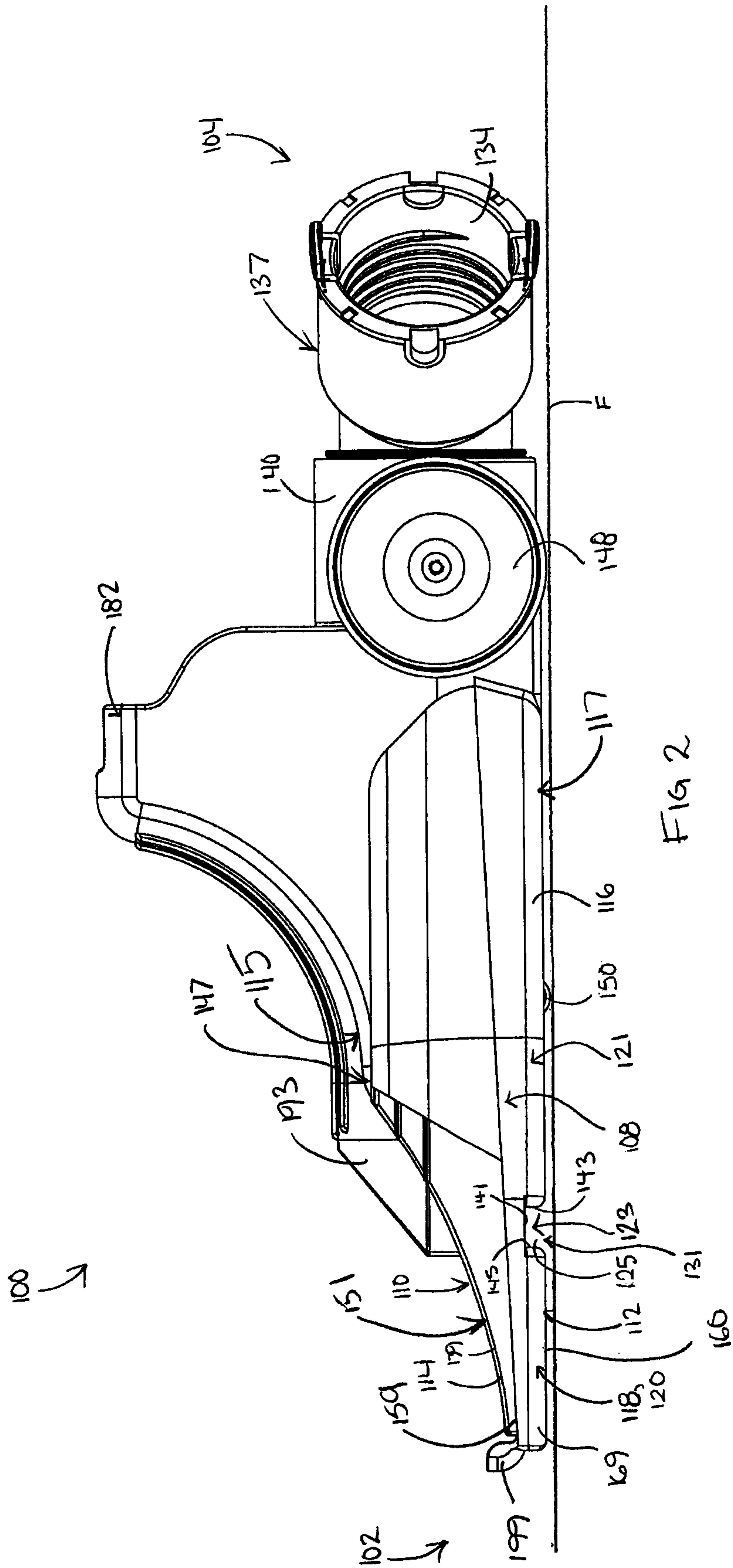

FIG 1





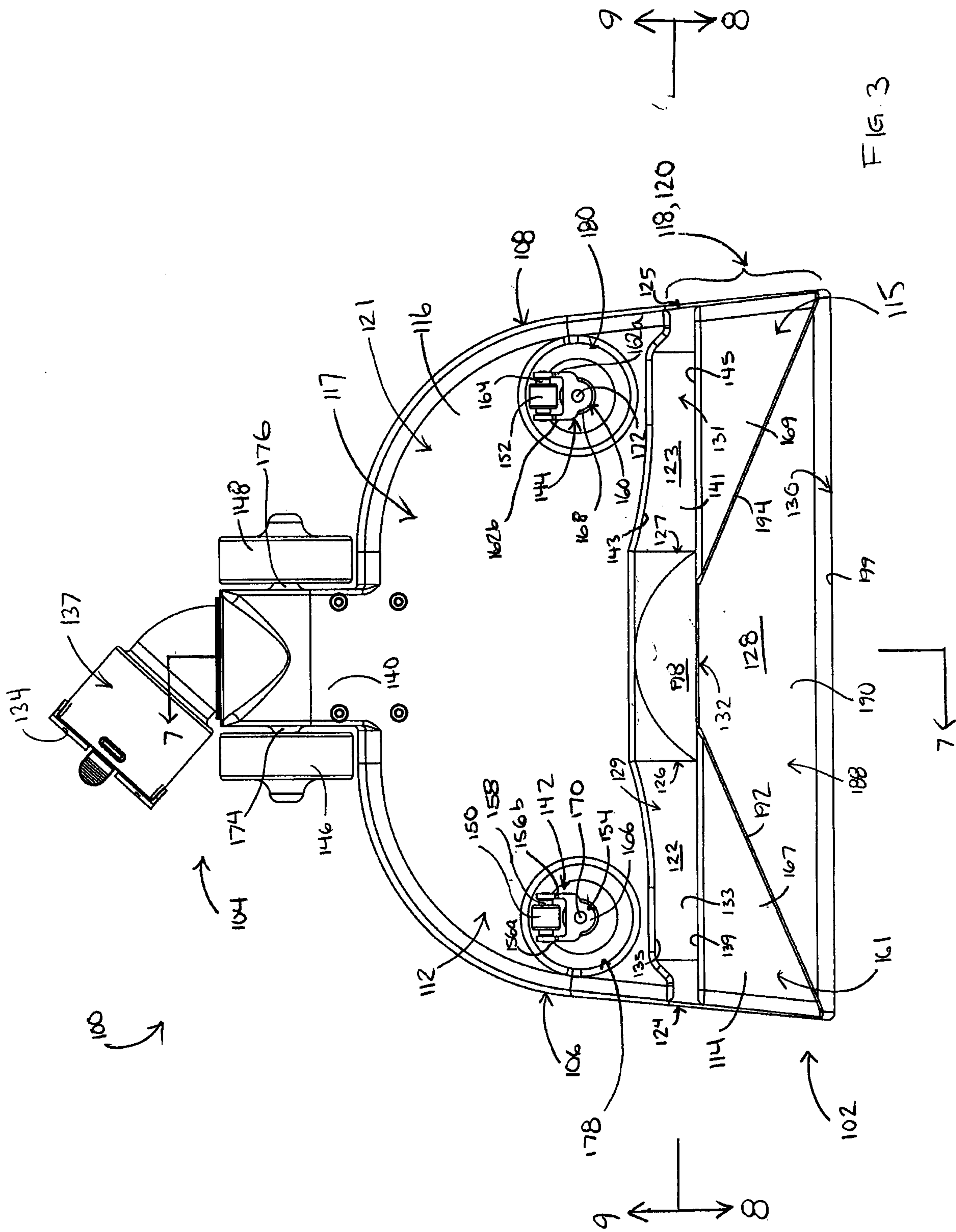

FIG. 3

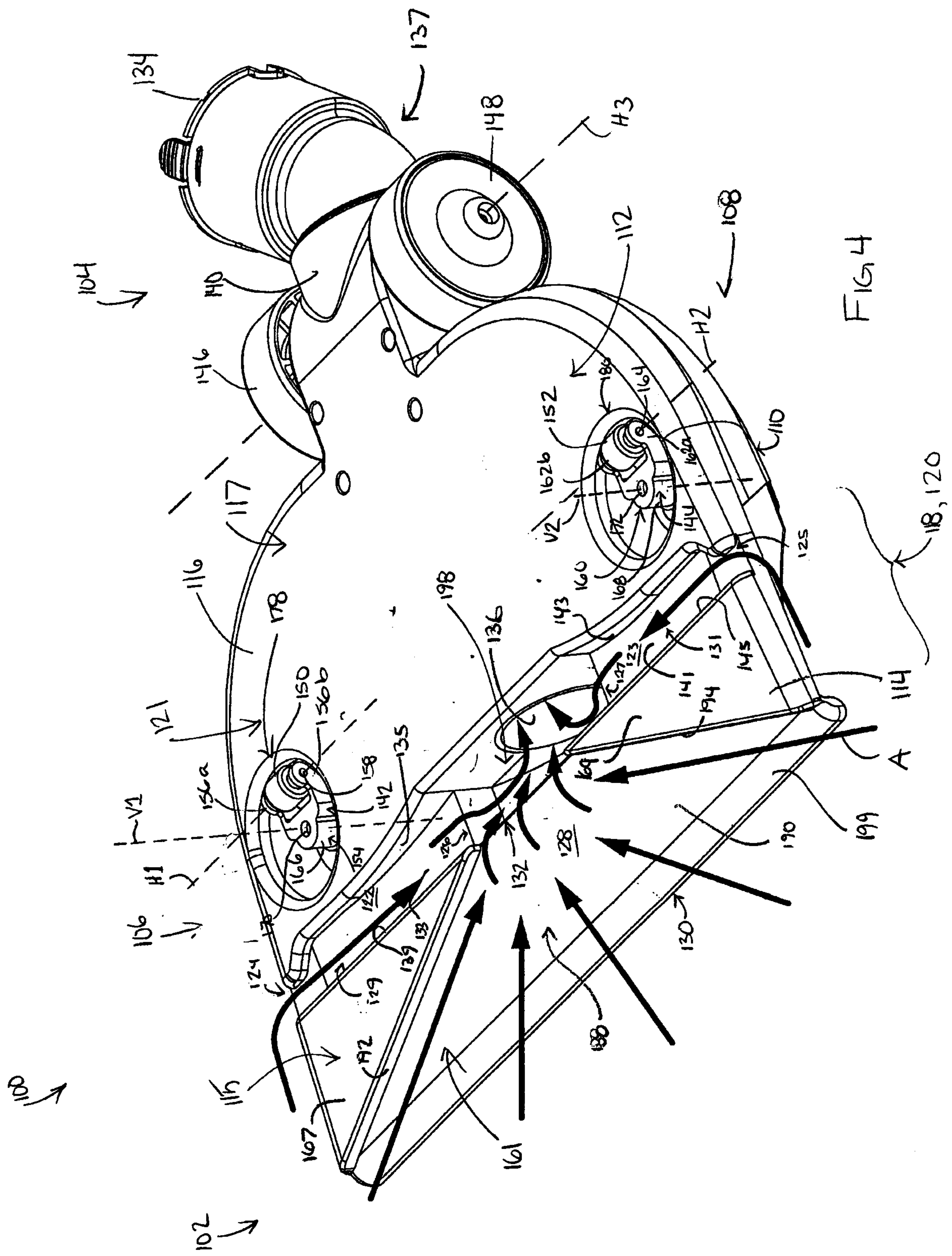
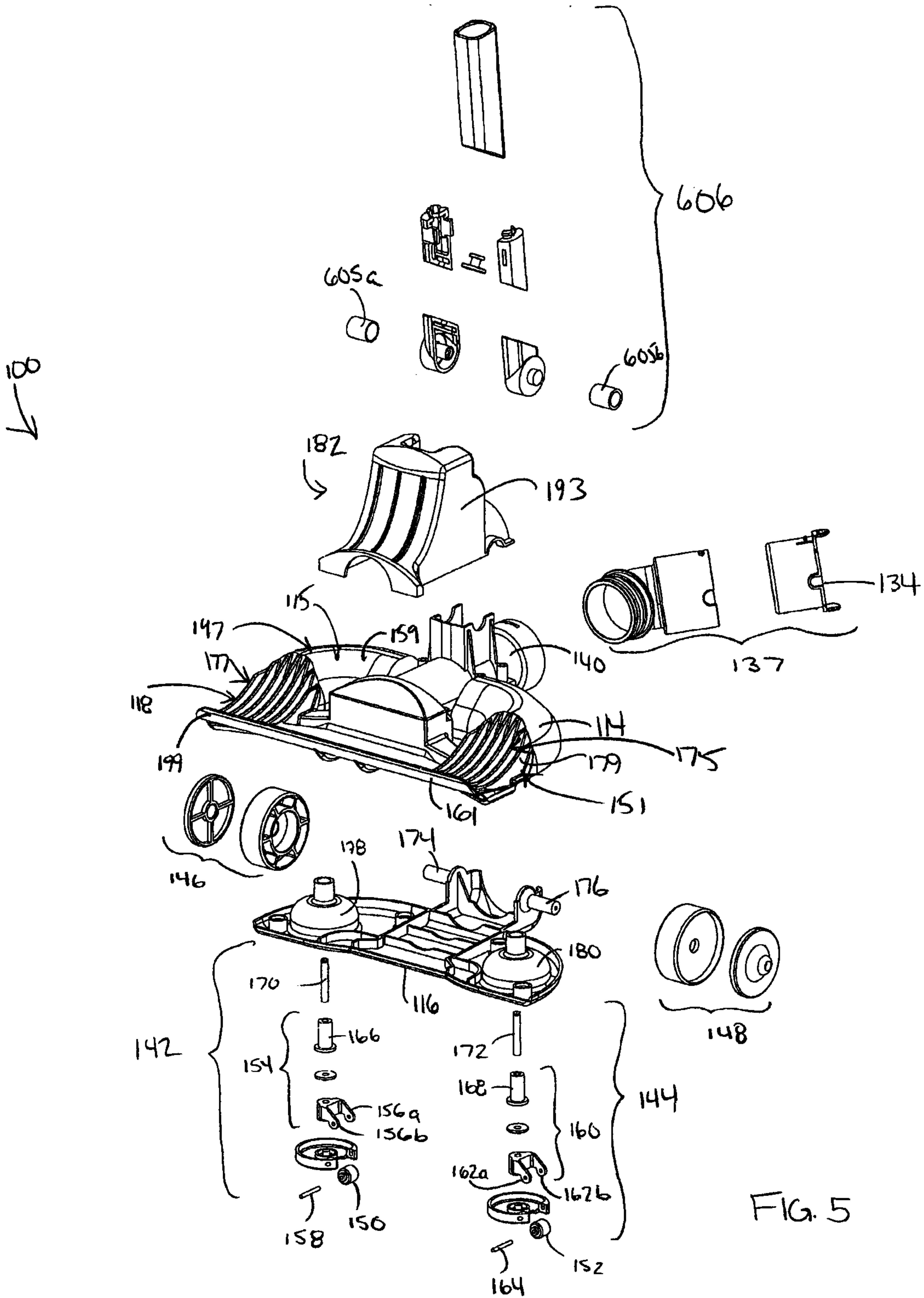

FIG 4

118, 120





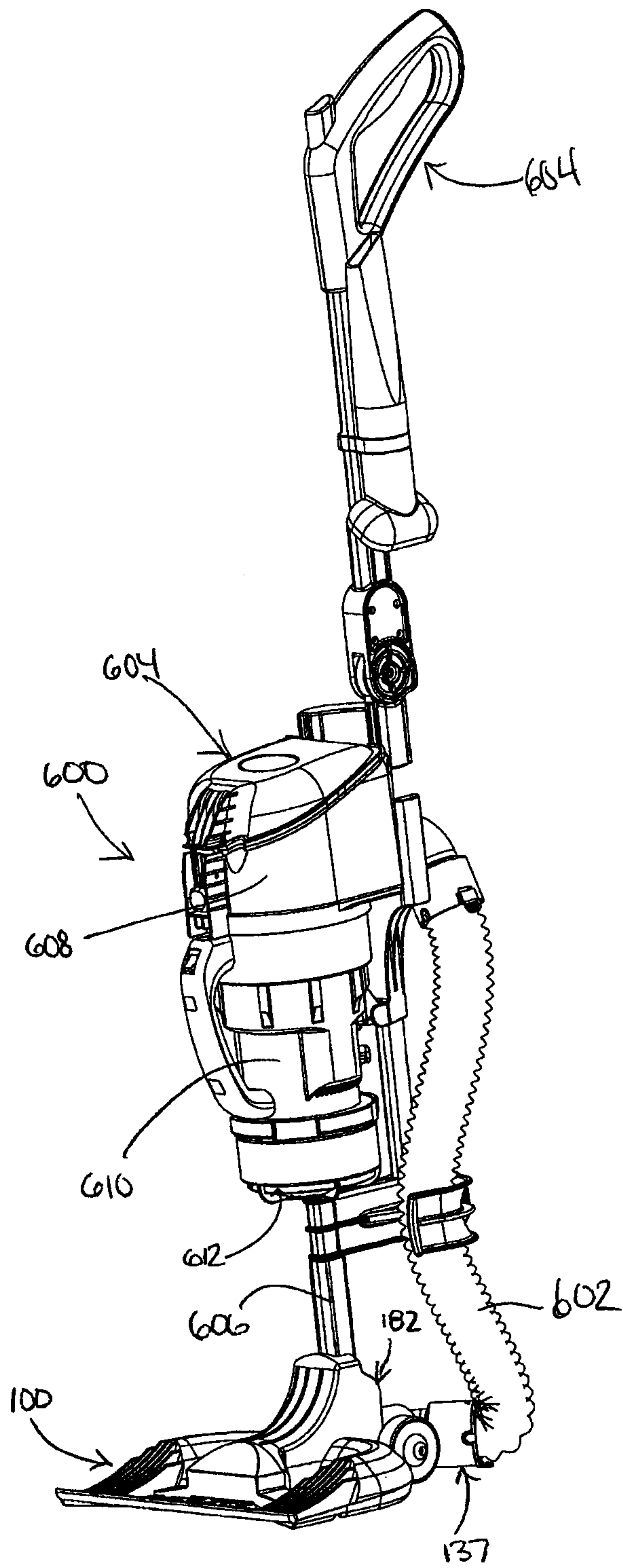
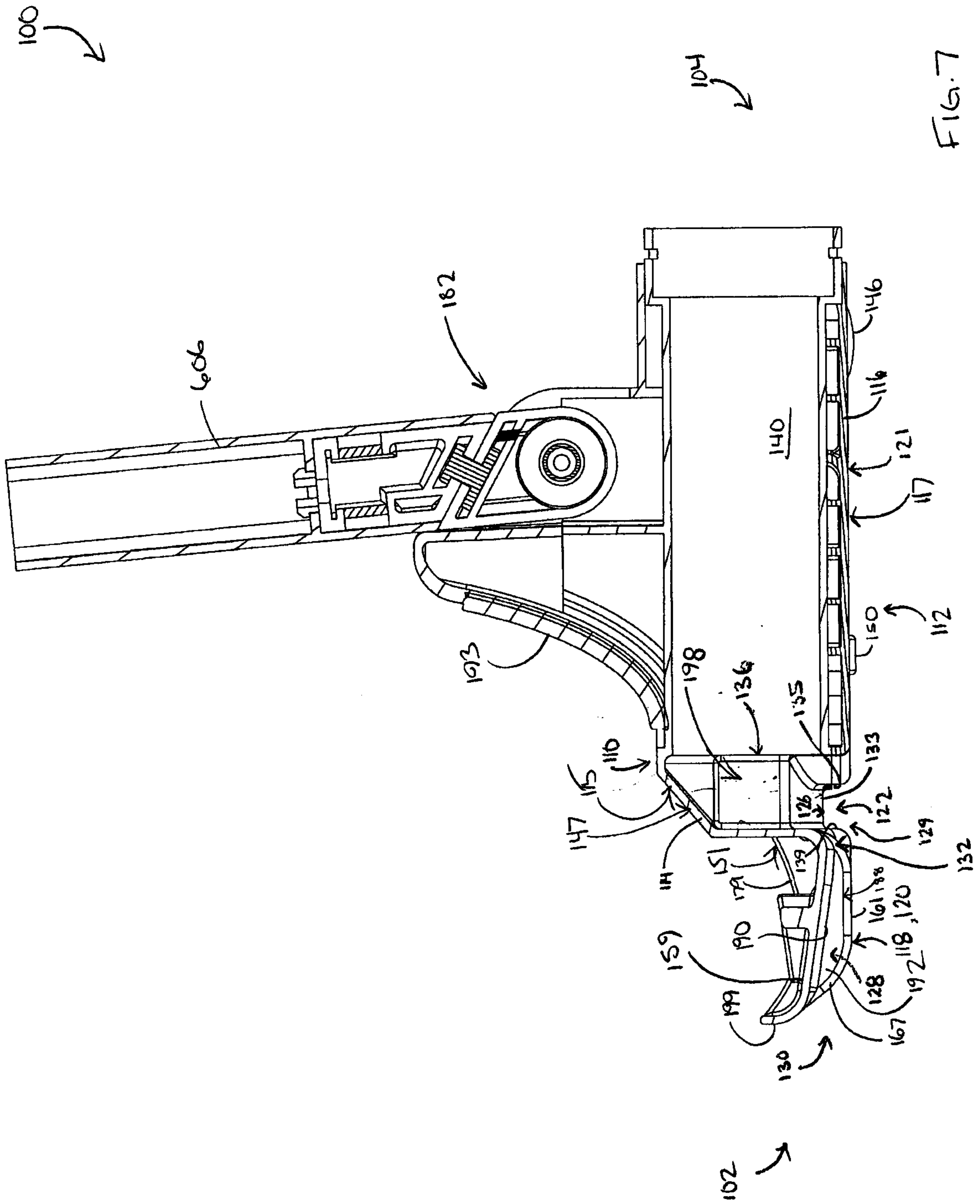

FIG. 6





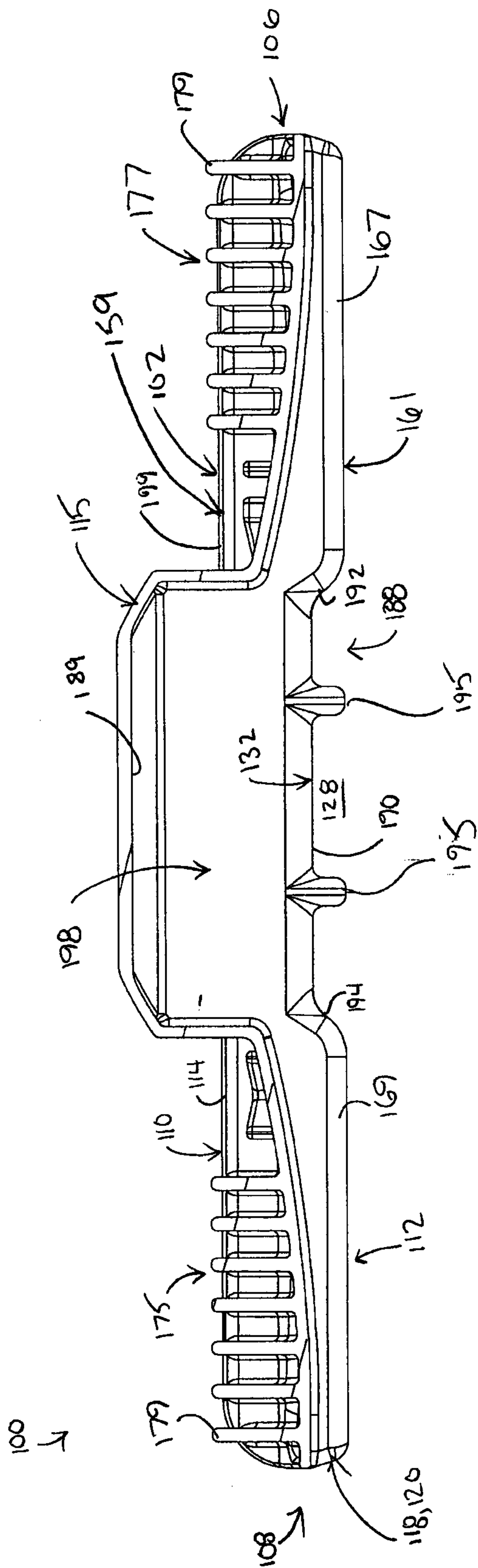

Fig 8

