

June 7, 1966

B. G. LESLEY

3,254,510

WARP KNIT PILE FABRICS

Original Filed May 11, 1962

2 Sheets-Sheet 1

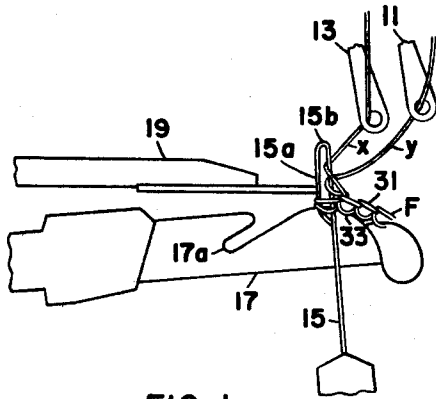

FIG. 1

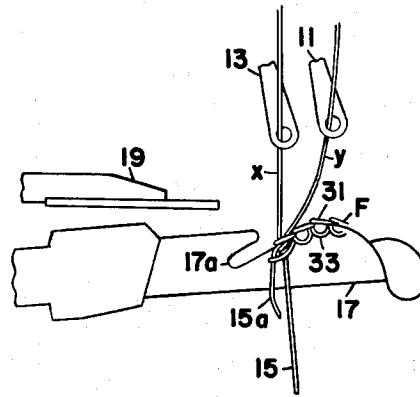

FIG. 2

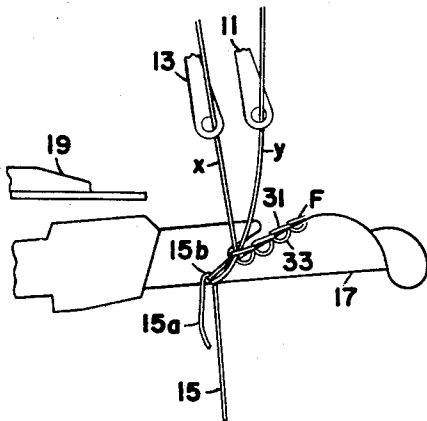

FIG. 3

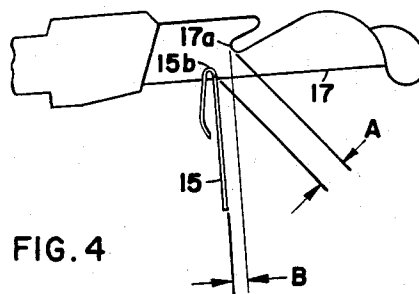

FIG. 4

INVENTOR.
BASCUM LESLEY
BY

Earle R. Marden
ATTORNEY

June 7, 1966

B. G. LESLEY

3,254,510

WARP KNIT FILE FABRICS

Original Filed May 11, 1962

2 Sheets-Sheet 2

FIG.-5-

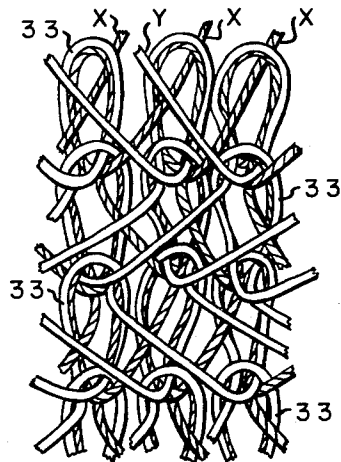
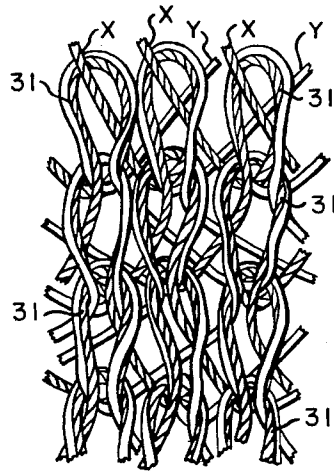

FIG.-6-

INVENTOR.
BASCUM G. LESLEY
BY

Earle R. Marden

3,254,510

WARP KNIT PILE FABRICS

Bascum G. Lesley, Pickens, S.C., assignor to Deering Milliken Research Corporation, Spartanburg, S.C., a corporation of Delaware

Original application May 11, 1962, Ser. No. 194,029. Divided and this application Dec. 23, 1964, Ser. No. 420,539

2 Claims. (Cl. 66—195)

This application is a division of my copending application Serial Number 194,029, filed May 11, 1962, which in turn is a continuation-in-part of my copending application Serial Number 804,418, filed April 6, 1959, and now abandoned.

This invention relates to novel knitted fabrics and methods for making the same and more particularly the invention relates to knit fabrics having a raised nap or pile surface effect on one face thereof.

It is known that knit fabrics having a pile or nap surface effect can be prepared by knitting a fabric with a large number of relatively long floats on the reverse side thereof, stretching the fabric lengthwise in such a manner as to result in slackening of the flat yarns, and thereafter brushing the fabric with a stiff brush to result in raising of the float yarns and to provide a raised nap or pile effect. Because of the two additional process steps which are necessary for making such fabrics and because of the care which must be exercised in performing these additional process steps, such fabrics are inherently quite expensive. Further, the originally formed flat lying floats in a knitted fabric have been caused to be raised by scouring the fabric, but such effects an uneven wavy raised float surface. In addition, the pile effect which can be obtained by such processes is quite limited because the loops formed by the float yarns are inherently quite open in nature and only a limited degree of slack can be introduced into the float yarns as a result of stretching the fabric.

It is an object of this invention to provide knit fabrics having more pronounced pile surface effects than were heretofore available.

It is another object of the invention to provide a simple inexpensive method for producing knit fabrics having pile surface effects.

It is still another object of the invention to provide methods for producing knit fabrics with a wider variety of pile surface effects than can be produced by prior art procedures.

According to this invention, a knit fabric having a pile surface effect is produced by a process which includes knitting a two bar fabric from first and second warp, one of the warps being formed of yarns of relatively high elasticity (i.e., capable of from about 10-50% or more elastic elongation before breaking) and being knitted under a relatively high tension such that stretched loops are pulled by the needles and small tight stitches are formed upon the retraction of the stretched elastic yarn loops formed of this yarn. The stitches from this highly tensioned warp, in large measure, give the fabric its body and size, and carry the stress load when the fabric is placed under tension. The second warp is knitted under a relatively low tension and such that the length of the warp yarn consumed in knitting the fabric is greater, and preferably at least about 40-50% or more greater, than would be required for knitting a balanced fabric of any given construction. By the term "balanced fabric" is meant a fabric in which the amount of yarn fed to and lying in the fabric is the amount required to equally accommodate all of the movements of the yarn guides and needles during fabric formation. It is the laps of the stitches formed from the loosely tensioned warp

that protrude from the small tight knit foundation of the fabric to produce a raised nap or pile effect. This pile effect may be accentuated by setting at a maximum, or increasing, the distance from the sinker throat to the needle head at the bottom of the needle travel, in order both to increase the length of the loops which are thereby drawn of the loosely tensioned yarn and to pull the preceding tight elastic yarn loops tighter and thereby push the loose loops to a further protruded position relative to the foundation of tight small stitches.

The invention will now be explained in greater detail with reference to the accompanying drawings in which:

FIGURE 1 is a schematic drawing showing the relative positions of one needle position of a conventional bearded needle tricot knitting machine after the overlap movement of the guides about the needles and the closing of the beard about the lapped yarn, with the next preceding fabric loops being landed onto the closed beards by the combined motion of the sinker bar and needles.

FIGURES 2 and 3 are further schematic views similar to FIGURE 1, and illustrate the further steps of knocking-over or casting off of the preceding tight elastic yarn loop (FIGURE 2) and the subsequent movement of the needle to the lowermost position thereof beneath the sinker throat to pull the loosely tensioned loop to a maximum length and to elastically stretch the highly tensioned elastic loop and also pull tighter the previously tight elastic loop.

FIGURE 4 is a schematic representation of the sinker and needle of FIGURE 1, illustrating various distances between the needle and sinker throat.

FIGURE 5 is a drawing of the back side (normally the face) of a two bar tricot knit fabric according to the invention, and

FIGURE 6 is a drawing of the face of the fabric of FIGURE 5 illustrating the raised lap portion of the stitches formed from the loosely knit warp which result in a pile effect.

The invention may be practiced with a conventional warp knitting machine having two sets of yarn guides 11, 13, mounted on guide bars, not shown, arranged for swinging and lateral endwise movement with respect to a corresponding plurality of needles 15 mounted in a needle bar, not shown, which needles are movable up and down with respect to corresponding plurality of sinkers 17 which are moved in and out with respect to the needle 15 during the knitting cycle to effect the landing and knocking over of the loops. The needles may be of the bearded, latch, or tongue type, the instant example being illustrated with respect to a bearded needle arrangement employing a conventional presser 19, which is movable in and out to selectively close and open the beards 15a of the needles, as in the conventional knitting cycle of such machines.

In knitting a fabric F in accordance with this invention, one warp of yarn X with a relatively high degree of elasticity is maintained under a relatively high tension, while the yarn Y of the other warp is held under relatively low tension, the tension differential being substantially greater than would be necessary to effect a balanced fabric of the two yarns. As a result of the difference in tensions, the stretched loop around each needle formed from a warp yarn under high tension tends to snap back and slide off of the needle appreciably before a loop around the same needle formed from an end of yarn from the warp under relatively low tension (see FIGURE 2), for the effective retracted length of the highly tensioned yarn forming the other loop for each needle is substantially less than the distance A between the throat and the head end of the needle at this lowermost position of the needle, whereas the amount of low

3

tensioned warp yarn pulled into the loop during the loop forming portion of the needle travel (see FIGURE 3) is approximately equal to or more closely equal to the distance A between the throat 17a of the sinker and the head 15b of the needle 15, the more highly tensioned elastic yarn being stretched a substantial amount to accommodate this descent of the needle, while upon upward movement and release of this loop the loop will retract to a substantially smaller effective length. The effective stitch length of the stitches 31 formed from the highly tensioned elastic warp yarn X is much less upon retraction than the stitch length of the stitches 33 formed of warp yarns of relatively low tension, due both to the difference in tension and the elasticity of the more highly tensioned yarns. The length and width dimensions of the fabric F are determined substantially by the stitches 31 formed from the retracted elastic warp yarns X which have been formed under a relatively high tension and the excess yarn in the stitches 33 formed from the warp Y under a relatively low knitting tension accumulates in the joining loop portions of the stitches and results in these portions of the stitches becoming raised from the surface of the fabric at the time of fabric formation. As illustrated in the schematic drawings of FIGURES 1-3, the raised pile or nap surface is formed by the stitches 33 of the yarn Y on the bottom side of the fabric, with the more highly tensioned elastic yarns X being more predominant in the foundation and on the upper side of the fabric.

In order to form the desired effectively small tight stitches 31 with the relatively elastic and highly tensioned warp yarns X it is desirable that the knitting machine should be set such that the fronts of the needles 15 are disposed relatively close to the throats 17a of the respective sinkers 17 when the sinkers are in their most forward position, i.e., the distance corresponding to that indicated by the letter B in FIGURE 4 of the drawing should be relatively short, dependent upon the number of courses per inch being formed in the fabric, and may be as low as zero distance for a fabric of high course number (e.g., 70-80 courses per inch). This is desirable in order to best accommodate the small tight knit stitches 31 formed by the highly tensioned elastic warp yarn as such stitches lie in the fabric and after retraction of the yarn X therein.

The extent of raised pile effect may be accentuated by adjustment of the needle height with respect to the sinker throat when the needle is in its lowermost loop forming position. It is desirable to adjust the needle height such that the heads 15b of the needles 15 are almost even with but slightly above the bottoms of the sinkers 17 when the needles 15 are in their lowermost position in order to accentuate the pile effect to a maximum extent for a given tension differential. This serves both to pull a desirably large length of loop in each of the loosely tensioned warp yarns, while stretching the more highly tensioned elastic warp yarn and thereby pulling more tightly the preceding stitch of highly tensioned elastic yarn, both of these results tending to increase the pile results. If less than the maximum possible raised pile height obtainable with this setting is desired, it can readily be obtained by decreasing the tension differential in the two warps. Normally, a pile effect of suitable intensity for any purpose can be readily achieved with the needle height adjusted as above described, but if an even more intense pile effect is desired, such can be obtained by equipping the knitting machine with deeper than normal sinkers and adjusting the needle height even lower than is possible with conventional sinkers.

It will be understood that the needle height adjustment mentioned above is of importance largely because it permits a greater differential in the knitting tensions of the two warps, and it is the large difference in tensions under which the two warps are knitted and the elasticity

4

of the higher tensioned warp yarns that are primarily responsible for the pile effect being obtained. The tension differential that is required is much larger than is normally encountered in an improperly adjusted machine on which an effort is being made to knit a balanced fabric, and for a fully satisfactory pile effect the tension difference should be at least 40% greater than would be required for forming a balanced fabric of the same construction, and preferably at least 50% more yarn is consumed in knitting the loose warp than would normally be used in knitting a balanced fabric of the same construction, although less tension differential and less excess yarn may be used if desired for a lesser degree of raised pile effect. For example, when knitting a pattern for a balanced fabric which requires the same amount of yarn for the front and back warps, such as a 1-0, 1-2; 1-2, 1-0 pattern, the run-in or take-up length for one warp should be at least 40% longer than the run-in length for the other warp. When the stitch pattern for the back warp is different from the stitch pattern for the front warp so that different amounts of the two warps are normally consumed in knitting a balanced fabric in order to accommodate the difference in warp yarns required for the balanced fabric, the above can readily be employed as a guide to produce a satisfactory fabric by calculating the approximate warp length ratio necessary to give a balanced fabric of the selected pattern, if this is not already known, and determining the tension differential necessary to provide a run-in length for one warp at least 40% in excess of the approximate length which would normally be required. For instance, in a fabric with floats formed on one surface and requiring perhaps 20% tension differential merely to accommodate the guide bar movements in forming the floats, the tension differential would preferably be increased to about 60% or more according to this invention, and the normally flat floats would be raised away from the more tight foundation stitches. There is no upper limit as to the difference in tensions between the two warps except that dictated by the considerations that the tight warp must not be so tightly tensioned with respect to its stretchability that excessive yarn or needle breaks are encountered and that the slack warp must not be so loosely tensioned that the needle cannot be drawn free of the loops formed therefrom.

In some instances above only two warps have been mentioned, but it will be understood that a fabric can be knit according to this invention on a three bar machine. In some instances, the third warp can be knit such as to complement either the warp knit under high tension or the warp knit under relatively low tension, or the third warp can be simply floated into the fabric for additional effects. Normally, however, a two bar knitting machine is employed in the manufacture of fabrics according to this invention, for the reasons that only two warps are necessary to give the desired results, and two bar machines generally operate at higher speeds, and for the further reason that two bar machines are more commonly available.

It is possible to knit fabrics according to this invention with the warp under a relatively high tension fed to either the back or front bar of a multi-bar knitting machine but it is generally preferred that the warp under a relatively high tension be fed through the guides 13 of the back bar and that the warp under a relatively low tension be fed through the guides 11 of the front bar. This is because as the loops are formed on the knitting needles, the yarns from the back bar guides 13 generally become disposed above the yarns fed from the front bar and since it is necessary for the loops in the yarns under a relatively high tension to be removed from the needles prior to the time that the loops formed from the warp under a relatively low tension are removed, less interference between the two yarns is encountered if the back guide bar is used for the high

5

tension yarns and the front guide bar is used for the warp yarns under a relatively low tension.

Almost any type of yarn can be employed as the lightly tensioned warp yarn forming the pile cover in the manufacture of fabrics according to this invention; however, the tighter tensioned warp must be formed of relatively elastic yarn (preferably capable of about 40 or 50% or more elastic elongation without breaking), continuous filament yarns generally being preferred and giving the most desirable results, although some staple yarns such as worsted yarns having a good elastic recovery after being stretched about 15-20% are usable to a degree as the more highly tensioned yarns. Examples of suitable yarns include 15 denier, 3 filament nylon, type 66; 40 denier, 13 filament nylon, type 6; 70 denier, 34 filament Dacron polyester yarn; and 100 denier, 40 filament Orlon acrylic yarn. The total denier of yarns employed according to this invention can range from 7 denier, for very sheer fabrics, to several thousand denier, for rugs or the like, and the denier per filament may range from about 0.8 to 20. Monofilament yarns also can be employed and interesting effects can be obtained with such yarns, particularly where the monofilaments have been processed to impart a crimped or exaggerated elastic nature thereto.

The knitting pattern employed is of no great importance except that it is generally preferable to employ a pattern for the highly tensioned warp yarns which would not result in splitting even in the absence of the other warp. Excellent pile effect can be obtained by the use of knitting pattern such as 1-0, 1-2 for the back warp knitted under high tension, and 1-2, 1-0 for the front warp knitted under low tension. If desired, however, more complicated patterns, such as float forming patterns, can be employed, and examples of other suitable patterns include: 1-0, 1-2 back; 2-3, 1-0 front; 1-0, 1-2 back; 3-4, 1-0 front; and 1-0, 1-2 back; 4-5, 1-0 front. Generally, it is desirable that both the high tension and the low tension warps be full but if area effects are desired, either one or, in some instances, both warps may be partial.

Conventional finishing procedures are suitable for fabrics made according to this invention and the usual steps are scouring, dyeing, and heat-setting. If desired, softening agents or other conventional processing agents can be applied. Likewise, if the fabric is knit partially or entirely from elasticized thermoplastic yarns, the fabric can be subjected to a conventional operation for intensifying the elastic nature of the yarn, and particularly the highly tensioned warp yarns.

The invention will now be illustrated by the following specific examples:

Example I

A 28 gauge Reiner Tricot machine adjusted such that the needles pass $\frac{60}{1000}$ in. under and $\frac{8}{1000}$ in. behind the

6

throats of the sinker, is loaded with two 20 denier, 7 filament nylon, type 66 warps. The pattern wheel for the front guide bar is set to knit a 2-3, 1-0 stitch and the pattern wheel for the rear guide bar is set to knit a 1-0, 1-2 stitch. The tension is adjusted such that the back bar runner length is 30 inches per rack and the front bar runner length is 75 inches per rack. This results in a fabric of about $3\frac{1}{2}$ inches quality that has, when finished, a beautiful suede appearance.

Example II

28 gauge Reiner Tricot machine adjusted as in the preceding example is loaded with two 40 denier, 13 filament nylon warps and the pattern wheel for the front guide bar is set to knit 1-0, 4-5, and the pattern warp for the rear guide bar is set to knit 1-2, 1-0. The tension adjustments are then made such that the runner length for the back warp is 33 inches and the runner length for the front guide bar is 112 inches. The resulting fabric has a very noticeable pile effect which results in a very desirable appearance and feel.

Having thus described my invention, what I desire to claim and secure by Letters Patent is:

1. A warp knit fabric having a face side formed from stitches of a first yarn and a back side formed from stitches from a second yarn, said face side stitches being knit such that they contain a length of yarn at least 40% in excess of that required for a balanced fabric construction, said second yarn being capable of substantial elastic elongation and being uniformly closely knit and uniformly raising said face side stitches to form said face side stitches of loosely knit yarn to provide a uniform pile effect on one face of said fabric.

2. The structure of claim 1 wherein said first yarn is capable of elastic elongation.

References Cited by the Examiner

UNITED STATES PATENTS

2,284,454	5/1942	Smith	66-194
2,435,897	2/1948	Newman	66-194

FOREIGN PATENTS

226,299	12/1924	Great Britain.
---------	---------	----------------

OTHER REFERENCES

"Man-Made Textile Encyclopedia," Textile Book Publishers, Inc., New York, 1959, page 112.

ROBERT R. MACKAY, *Acting Primary Examiner.*

RUSSELL C. MADER, *Examiner.*

P. C. FAW, *Assistant Examiner.*