



(72) MOLLER, Brent, DK

(72) ULRIKSEN, Ulrik, DK

(71) VELUX INDUSTRI A/S, DK

(51) Int.Cl.⁶ E06B 9/56, E04D 13/03

(30) 1996/06/18 (0675/96) DK

(54) **PARE-SOLEIL EXTERIEUR POUR TABATIERE PIVOTANTE**

(54) **AN EXTERNAL SCREENING DEVICE FOR A PIVOTABLE
SKYLIGHT WINDOW**

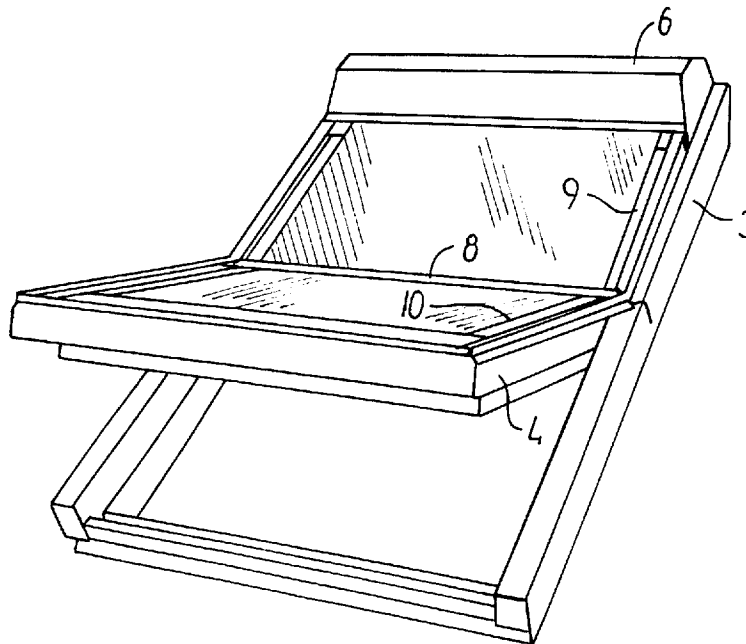

(57) L'invention porte sur un pare-soleil extérieur pour tabatière pivotante comprenant une toile (5) d'un matériau écran enroulée autour d'un rouleau rappelé par ressort (11) et solidaire d'une barre inférieure (7) guidée par des rails latéraux (9, 10) et reliée par un cordon de commande (14, 15) à une unité de déroulement (12, 13). Les rails latéraux (9, 10) de guidage de la barre inférieure (7) sont disposés le long des portions (3) des parties latérales du cadre situées au-dessus de l'axe de rotation (2) et le long de la portion (4) des parties latérales du

(57) An external screening device for a pivotable skylight window comprises a web (5) of a screening material which is wound on a spring-biased roller (11) and is connected with a bottom bar (7) guided in side guide rails (9, 10) which is connected via a cord drive (14, 15) with an unrolling drive unit (12, 13). The side guide rails (9, 10) for the bottom bar (7) run along the parts (3) of the frame side portions situated above the axis of rotation (2) and the parts (4) of the sash side portions situated below the axis of rotation (2), and an essentially rod-



(21) (A1) **2,253,815**
(86) 1997/06/17
(87) 1997/12/24

châssis situées au-dessous de l'axe de rotation (2), tandis qu'un support sensiblement en forme de tube (8) fixé à la toile écran (5) et la traversant est engagé dans les rails latéraux (9, 10) de manière à se trouver, quand la toile écran est déployée, sur ou à côté de l'axe de rotation (2), tout en lui étant parallèle. Le dispositif peut comporter des moyens pour tendre ou détendre la toile (5) en lorsqu'elle est entièrement déployée ou pendant son réenroulement.

shaped support device (8) is attached to and extends across the screening web (5) and is led in the side guide rails (9, 10) so that in a position of use for the screening device it is positioned at or close to the axis of rotation (2) in parallel therewith. The device may be provided with means for retightening and smoothing the web (5) in the fully drawn position and during rewinding.



PCT

WORLD INTELLECTUAL PROPERTY ORGANIZATION
International Bureau

INTERNATIONAL APPLICATION PUBLISHED UNDER THE PATENT COOPERATION TREATY (PCT)

(51) International Patent Classification ⁶: E06B 9/56 // E04D 13/02	A1	(11) International Publication Number: WO 97/48872 (43) International Publication Date: 24 December 1997 (24.12.97)
(21) International Application Number: PCT/DK97/00260 (22) International Filing Date: 17 June 1997 (17.06.97) (30) Priority Data: 0675/96 18 June 1996 (18.06.96) DK (71) Applicant (for all designated States except US): V. KANN RASMUSSEN INDUSTRI A/S [DK/DK]; Tobaksvejen 10, DK-2860 Søborg (DK). (72) Inventors; and (75) Inventors/Applicants (for US only): MØLLER, Brent [DK/DK]; Østerkildevvej 1, DK-2820 Gentofte (DK). ULRIKSEN, Ulrik [DK/DK]; Fyrstenborgvej 9, DK-6900 Skjern (DK). (74) Agents: RAFFNSØE, Knud, Rosenstand et al.; International Patent-Bureau, Høje Taastrup Boulevard 23, DK-2630 Taastруп (DK).		(81) Designated States: AL, AM, AT, AU, AZ, BA, BB, BG, BR, BY, CA, CH, CN, CU, CZ, DE, DK, EE, ES, FI, GB, GE, GH, HU, IL, IS, JP, KE, KG, KP, KR, KZ, LC, LK, LR, LS, LT, LU, LV, MD, MG, MK, MN, MW, MX, NO, NZ, PL, PT, RO, RU, SD, SE, SG, SI, SK, TJ, TM, TR, TT, UA, UG, US, UZ, VN, YU, ZW, ARIPO patent (GH, KE, LS, MW, SD, SZ, UG, ZW), Eurasian patent (AM, AZ, BY, KG, KZ, MD, RU, TJ, TM), European patent (AT, BE, CH, DE, DK, ES, FI, FR, GB, GR, IE, IT, LU, MC, NL, PT, SE), OAPI patent (BF, BJ, CF, CG, CI, CM, GA, GN, ML, MR, NE, SN, TD, TG). Published <i>With international search report.</i> <i>In English translation (filed in Danish).</i>

(54) Title: AN EXTERNAL SCREENING DEVICE FOR A PIVOTABLE SKYLIGHT WINDOW**(57) Abstract**

An external screening device for a pivotable skylight window comprises a web (5) of a screening material which is wound on a spring-biased roller (11) and is connected with a bottom bar (7) guided in side guide rails (9, 10) which is connected via a cord drive (14, 15) with an unrolling drive unit (12, 13). The side guide rails (9, 10) for the bottom bar (7) run along the parts (3) of the frame side portions situated above the axis of rotation (2) and the parts (4) of the sash side portions situated below the axis of rotation (2), and an essentially rod-shaped support device (8) is attached to and extends across the screening web (5) and is led in the side guide rails (9, 10) so that in a position of use for the screening device it is positioned at or close to the axis of rotation (2) in parallel therewith. The device may be provided with means for retightening and smoothing the web (5) in the fully drawn position and during rewinding.

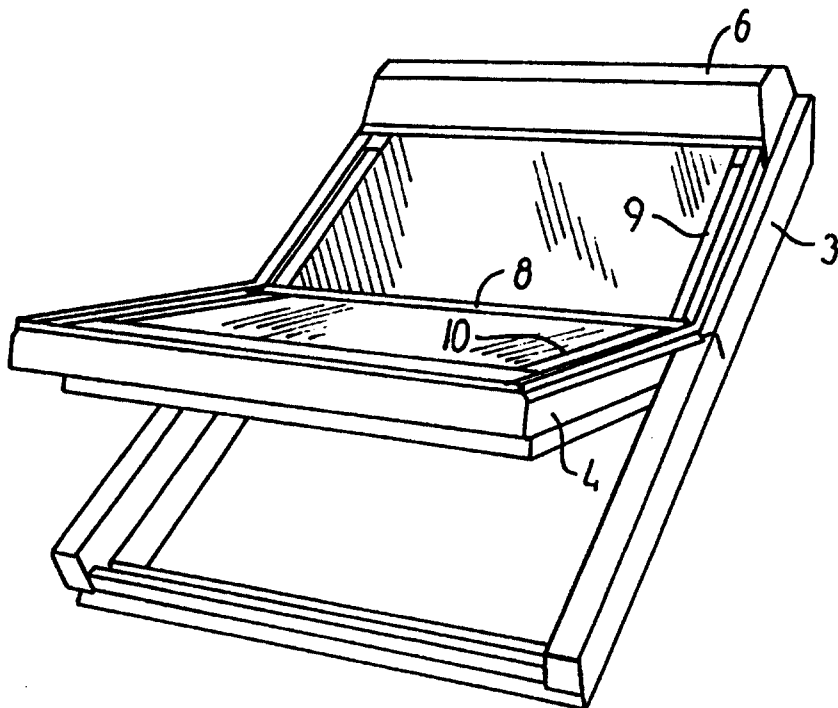

An external screening device for a pivotable skylight window

The present invention relates to an external
5 screening device for a pivotable skylight window with
a horizontal axis of rotation of a sash in a centre
area of the main frame of the window, comprising a
continuous flexible screen which is wound on a roller
situated at an upper horizontal frame portion of the
10 window and is connected at its free end with a bottom
bar guided in side guide rails, said bottom bar being
connected for unrolling the screen over a cord drive
with a drive unit which is also positioned in connec-
tion with the upper horizontal frame portion, said side
15 guide rails for the bottom bar extending along the
parts of the frame side portions placed above the axis
of rotation and the parts of the sash side portions
placed below the axis of rotation.

The two-part design of the side guide rails with
20 upper sections running along the top part of the frame
side portions and lower sections running along lower
parts of the sash side portions is known per se from
US-A-4 691 753 for a screening device in the form of a
roller shutter with relatively rigid slats guided in
25 the side guide rails. The document as such deals with
a design of the control cables which prevent jamming of
the rigid slats in the guide rails.

From US-A-1 583 133 there is known a screening
device with a flexible material which is guided in
30 hinged side rails and has rigid supporting rods for
preventing sagging of the screening material. This
screening device is not intended for a pivotable
window, and the hinged guiding rails are, when in use,
mounted on a window frame or equivalent in an aligned
35 manner. The hinge itself is only used for folding the

AMENDED SHEET

1a

guide rails during shipment so as to save space. During shipment the flexible material is not present in the guide rails but wound on a roller.

If an external screening made of a flexible web is used in connection with a pivotable skylight window, eg. as shown in fig, 1., where the lower portion of the window sash below the axis of rotation is turned outwards under an angle with the frame of typically between 10° and 60°, it is a problem that the screening web which extends between the upper horizontal frame portion and the lower horizontal sash portion shows a pronounced tendency to flutter or flap even by minor wind loads which partly involves the risk of wear and tear of the web, partly makes an annoying noise, while at the same time the esthetic appearance is deteriorated and light may penetrate through the uncovered opening between the web and the frame/sash construction.

Furthermore, when the window is closed, such screening devices have a tendency in a drawn-out condition and with a wet web to make the web stick to



the pane which again, especially when seen from the inside, provides a severely deteriorated esthetic appearance, and in addition can entail problems with rewinding the web on the roller.

5 According to the invention these problems may in all essentials be solved in that the screen comprises a continuous web of a flexible material associated with an essentially rod-shaped support device which extends across the web essentially parallel to the bottom bar
10 and is guided in the side guide rails, said support device being positioned, in a position of use for the screening device, at or close to the axis of rotation and parallel thereto.

 Thereby, it is ensured that the web in unrolled
15 condition follows the part of the frame construction positioned above the axis of rotation and the part of the sash construction positioned below the axis of rotation.

 In a relatively simple embodiment, the support
20 device may comprise a stiffening ledge fastened to the web in parallel with the bottom bar and at a distance herefrom corresponding essentially to the distance of the axis of rotation from the lower horizontal sash element. In this way, a low-cost production and
25 mounting are obtained.

 In particular by designs where the rewinding is not effected by means of spring power from a spring-biased roller such that a screening web unrolled at a closed window will flap heavily when opening the

AMENDED SHEET

window, an essential esthetic improvement is obtained.

According to a further development of the invention, the support device may instead comprise a ledge which is displaceable with respect to the web and
5 releasably coupled with the bottom bar whereby in the area opposite the axis of rotation, the side guide rails are provided with means for releasing the interconnection between the bottom bar and said ledge and arresting of the latter during continuous unrolling
10 movement of the bottom bar.

Thereby, the ledge will function optimal with a correct positioning at the axis of rotation even though the web is not fully rolled out.

In a very simple and inexpensive design, a ledge
15 of the stated kind may be positioned across the web without any other connection therewith than said releasable coupling to the bottom bar.

Furthermore, it is advantageous if means for retightening the web in the fully drawn position are
20 connected to the drive unit or the cord drive.

Such tightening means may according to a preferred embodiment be realized in that the drive unit for the unrolling movement is an electric motor with means comprising a sensing device for switching-off the current
25 for the motor in said fully drawn position of the screening web during simultaneous securing of the retightening of the web.

A further advantageous design is obtained if in the vicinity of and parallel to the roller, a device in
30 the form of a rod or a cylinder is provided for retightening and smoothing of the web during rewinding. Such a device will furthermore entail that precipitation in the form of snow or icing gathered on the web will be broken so that it may slide down from web or be
35 removed from the web in order not be rewound together

with the web.

The invention is explained in the following with reference to the schematic drawing where

Fig. 1 illustrates a screening device known per se
5 and used in connection with a pivotable skylight window,

Fig. 2 is a perspective view of a pivotable skylight window with a first embodiment of the screening device according to the invention,

10 Figs. 3-6 illustrate another embodiment of the screening device in different positions of the screening web,

Fig. 7 is a modification of the embodiment in Figs. 3-6,

15 Figs. 8 and 9 show alternative embodiments of means for releasable interconnection of a screening device as shown in Figs. 3-7 with the bottom bar of the web, and

Fig. 10 is a perspective view of an embodiment
20 having means for retightening and smoothing the web during the movement of unrolling and rewinding.

In the schematic side view in Fig. 1, numeral 1 represents a pivotable skylight window mounted in an inclined roof surface and with an axis of rotation for
25 the pivot movement situated at 2 in a centre area of the window frame and sash of which the figure only shows the part 3 of a frame side portion situated above the axis of rotation and the part 4 of a sash side portion situated below the axis of rotation.

30 An external screening device in the form of a roller screen comprises a continuous web 5 of a flexible screening material, which can be wound on a roller bar not shown in the figure, said roller bar being placed in a top casing 6 at the upper horizon-
35 tal frame portion of the window and being connected at

its free end with a bottom bar 7 which is guided in not shown side guide rails mounted on the parts 3 and 4 of the side portions of the frame and sash, respectively.

5 In the illustrated open position of the window, the screening web will in a fully unrolled condition be stretched out between the upper horizontal frame portion and the bottom bar 7 positioned at the lower horizontal sash portion and even at small wind blasts
10 it will show a strong tendency to flutter resulting in the aforesaid disadvantages.

In the screening device according to the invention shown in Figs. 2-6, for which parts corresponding to those shown in Fig. 1 are designated by the same referential numerals, this disadvantage is remedied in that
15 an essentially bar-shaped support device in the form of a stiffening ledge 8 or 18, respectively, is attached to and extends across the screening web 5 and is guided in the same side guide rails 9 and 10 as the
20 bottom bar 7.

The stiffening ledge 8 or 18 respectively, may be manufactured of plastics, wood or metal with an arbitrary cross-sectional profile. In a simple and inexpensive design it may as shown in Fig. 2 consist of one
25 ledge profile 8 which by sewing in, riveting, gluing, welding or in a similar way has been fastened directly to the web 5 on the place which in the unrolled position lies opposite the axis of rotation 2 of the window. The stiffening ledge 8 will thus constantly
30 follow the web 5 during unrolling and rewinding.

As the stiffening ledge 8 is guided in the side guide rails 9 and 10 mounted on the parts 3 of the frame side portions positioned above the axis of rotation 2 and the parts 4 of the sash side
35 portions positioned below the axis of rotation 2,

respectively, the web 5 with the stiffening ledge 8 mounted in an unrolled condition will be made to follow the outlines of the said parts of the frame and sash constructions.

5 As appears from Figs. 3-6 showing schematic side views of a pivotable skylight window with a screening device according to the invention the stiffening ledge, which here is designated by 18, may alternatively be designed as a double or slotted ledge profile in
10 displaceable connection with the web 5 and comprising two parts 18a and 18b situated on either side of the web.

In this design the stiffening ledge 18 is releasably coupled to the bottom bar 7, eg. by means of
15 clips, magnets, hooks or alike or by capsizing, and as further appears from the following in connection thereto means not shown in Figs. 3-6 are provided at the bend between the side guide rails 9 and 10 for releasing the interconnection between the bottom bar
20 7 and the stiffening ledge 18, so that during continuous unrolling movement of the bottom bar, the ledge will be maintained arrested in a position parallel to and in the vicinity of the axis of rotation 2, as is best seen in Fig. 6.

25 However, as shown in Fig. 7, a support device with the same function may also shown in Fig. 7, in a more simple design be designed as a ledge 18' positioned across the web without any other connection therewith than the releasable coupling to the bottom bar 7.

30 In the embodiment in Fig. 8, the parts 19 and 20, respectively, of the stiffening ledge 18 and the bottom bar 7 guided in the side guide rails are interconnected, e.g. magnetically, and the guide element 19 for the stiffening ledge 18 is at least
35 at one side designed with an engagement groove 21

which can enter in engagement with a hooked end part 22 of a stop device in the form of a bent spring element 23 mounted on the outside of the side guide rails at the transition between the rails 9 and 10 and protruding into the rail cavity through an aperture 24 such that after passage of the guide element 20 designed with smooth side faces it may enter into engagement with the groove 21 with its hooked end part 22.

10 In the embodiment in Fig. 9, the interconnection between the stiffening ledge 18 and the bottom bar 7 is provided in that the guide element 25 for the stiffening ledge 18 is enveloped by a clip-like coupling element in the form of a bent spring element 15 26 with hooked end parts 27 which during movement of the guide elements in the side guide rail 9 connected to the part 3 of a frame side portion situated above the axis of rotation grasps the guide element 28 connected to the bottom bar, but at the break point 20 between the side guide rails 9 and 10 as a consequence of the spring bias is forced outwards in openings 29 between the two side guide rails 9 and 10.

The releasable interconnection between the stiffening ledge 18 and the bottom bar can of course be 25 designed in many other ways.

In order to avoid that the screening web 5 in the fully unrolled position shown in Fig. 5 at a closed window tends to stick to the outer face of the window pane which entails a strongly reduced esthetic appearance, especially when seen from within, means for 30 retightening the web in the fully drawn position are, according to the invention, attached to the drive unit or cord drive for the unrolling movement of the screening web 5.

35 In the embodiment in Fig. 10, the screening web

5 is wound on a spring-biased roller 11 such that the rewinding movement of the web is effected by means of the thus produced spring force which in itself contributes to keeping the web 5 tightened in any 5 position. The roller will, however, not always be spring-biased as both the rewinding and unrolling movement may be effected by means of cord drive.

The unrolling movement is here electrically activated by means of a drive unit in the form of a not 10 shown tubular motor positioned inside the roller 11 and provided with output shafts 12 which are coupled to two rewinding drums 13 positioned at each end of the roller for a cord drive comprising two draw cords 14 and 15 which via reversing reels 16 at the bottom 15 of the side guide rails 10 connected with the part 4 of each sash side portion placed below the axis of rotation 2 are led into the bottom bar 7 where ends of the cords 14 and 15 are connected over a retightening spring 17.

20 The special retightening means according to the invention are preferably electrically activated.

As one possibility for such an electrical activation, there may in connection with the motor control circuit for the drive motor be mounted a sensing device 25 measuring the motor current and disrupting it at a certain overcurrent or breaking level obtained by tightening the draw cords 14 and 15 when the bottom bar 7 reaches its bottom position corresponding to a complete unrolling of the web. Before this breaking 30 level is attained, the retightening spring 17 in the bottom bar will, however, be fully stretched with the result that too much web is unrolled such that the unrolled web is slackened and tends to rest directly against the pane or stick thereto.

35 According to the invention this can be counter-

acted by such an arrangement of the motor control circuit that in connection with detecting the breaking level the circuit ensures a short reverse of the drive motor such as to run backwards for e.g. 1 sec. whereby
5 the spring bias on the roller 11 assures the retightening of the web 5.

As another possibility there may in connection with each of the side guide rails 10 be mounted a contact element, e.g. a Hall-element with a sensor 30
10 which is affected by an element 31 directly connected with the web for indicating whether the web 5 is fully unrolled and thus ensures disruption of the motor current when too much web is rolled out.

As an alternative to this possibility, there may
15 in connection with the motor output shafts 12 be placed a tacho disc affecting a contact element, e.g. a Hall-element for sending information to a microprocessor indicating how many rotations the drive motor has made in order that the number of rotations corre-
20 sponding to a fully, but not too much, unrolled web can be stored and used for disruption of the motor before too much web is rolled out.

In the embodiment in Fig. 10, there is furthermore in the vicinity of and parallel to the roller bar 11
25 arranged a device 33 in the form a rod or a roller which through pressure on the web 5, e.g. by means of a spring bias 34 results in a retightening and smoothing of the web during rewinding. Such a retightening and smoothing device will further entail that
30 precipitation in the form of snow or icing which has gathered on the web will be broken and thus slide down from the web or be removed in order not to be rewound together with the web.

P A T E N T C L A I M S

1. An external screening device for a pivotable skylight window with a horizontal axis of rotation (2) of a sash in a centre area of the main frame of the window, comprising a continuous flexible screen which is wound on a roller (11) situated at an upper horizontal frame portion of the window and is connected at its free end with a bottom bar (7) guided in side guide rails (9, 10), said bottom bar being connected for unrolling the screen over a cord drive (14, 15) with a drive unit (12, 13) which is also positioned in connection with the upper horizontal frame portion, said side guide rails (9, 10) for the bottom bar (7) extending along the parts (3) of the frame side portions placed above the axis of rotation (2) and the parts (4) of the sash side portions placed below the axis of rotation (2), characterized in that the screen comprises a continuous web (5) of a flexible material associated with an essentially rod-shaped support device (8, 18) which extends across the web (5) essentially parallel to the bottom bar and is guided in said side guide rails (9, 10), said support device (8, 18) being positioned, in a position of use for the screening device, at or close to the axis of rotation (2) and parallel thereto.

2. A screening device according to claim 1, characterized in that the support device comprises a stiffening ledge (8) fastened to the web (5) at a distance from the bottom bar (7) corresponding essentially to the distance of the axis of rotation (2) from a lower horizontal sash element of the window.

3. A screening device according to claim 1, characterized in that the support device comprises a ledge (18) displaceable with respect to the web (5) and releasably coupled with the bottom bar (7),

10a

whereby in the side guide rails (9, 10) in the area

opposite the axis of rotation (2) means (21-24; 26-29) are provided for releasing the interconnection between the bottom bar (7) and said ledge (18) and arresting of the latter during continuous unrolling movement of the
5 bottom bar (7).

4. A screening device according to claim 3, c h a r a c t e r i z e d in that the ledge (18) is arranged across the web without any other connection therewith than said releasable coupling to the bottom bar.

10 5. A screening device according to claim 3, c h a r a c t e r i z e d in that the ledge (18) is designed as a double or slotted ledge profile with two parts (18a, 18b) placed on either side of the web.

6. A screening device according to any of the
15 preceding claims, c h a r a c t e r i z e d in that means for retightening the web (5) in the fully drawn position are attached to the drive unit (12, 13) or the cord drive (14, 15) for the unrolling movement.

7. A screening device according to claim 6, c h a r a c t e r i z e d in that the drive unit for the
20 unrolling movement is an electric motor with means comprising a sensing device for switching-off the motor current in said fully drawn position of the screening web (5) during simultaneous securing of the retighte-
25 ning of web.

8. A screening device according to claim 7, c h a r a c t e r i z e d in that said sensing device comprises an overcurrent sensor for the motor current in connection with means for short reversal of the
30 motor after said switching-off of the motor current.

9. A screening device according to claim 7, c h a r a c t e r i z e d in that said sensing device comprises a contact member (30) arranged at the lower part of a side guide rail (10) and actuated by a member
35 (31) connected with the web.

10. A screening device according to claim 9, characterized in that said contact member is a Hall member.

11. A screening device according to one of the 5 preceding claims, characterized in that in the vicinity of and parallel to the roller (11) a rod-shaped or cylindrical device (33) is provided for retightening and smoothing the web (5) during rewinding.

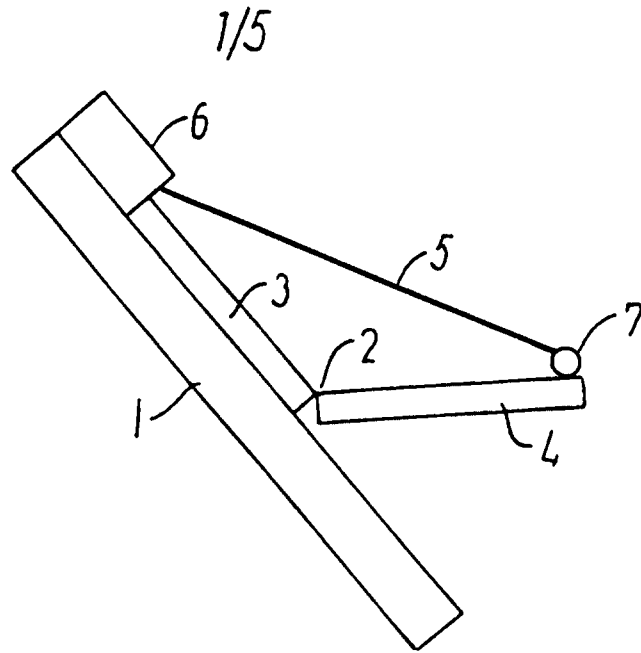

FIG. 1

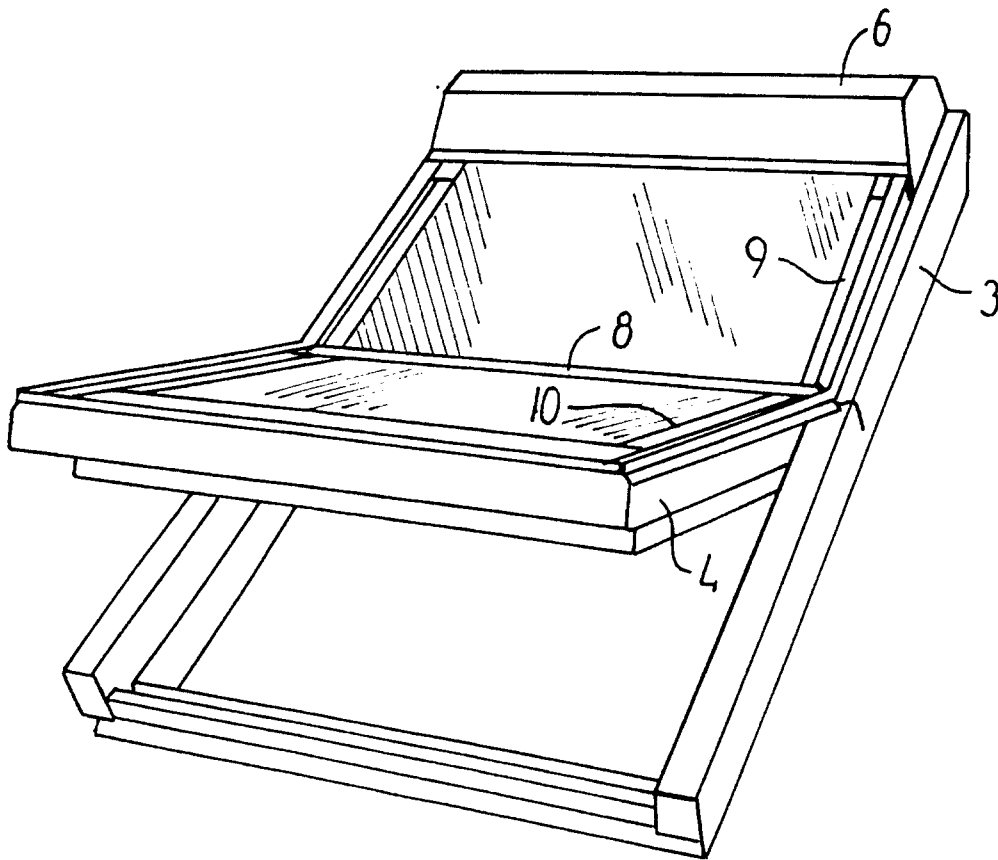

FIG. 2

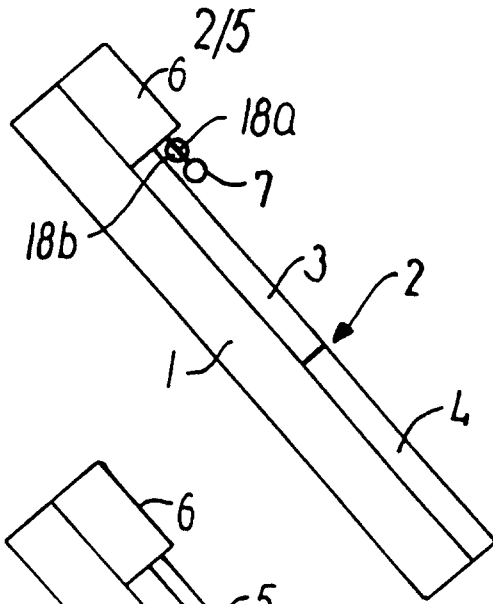

FIG. 3

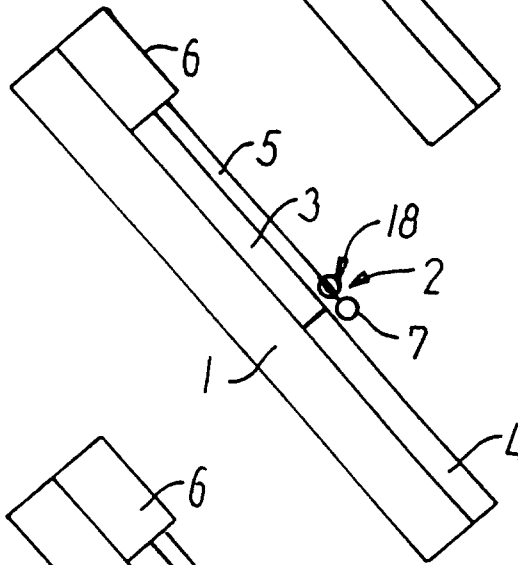

FIG. 4

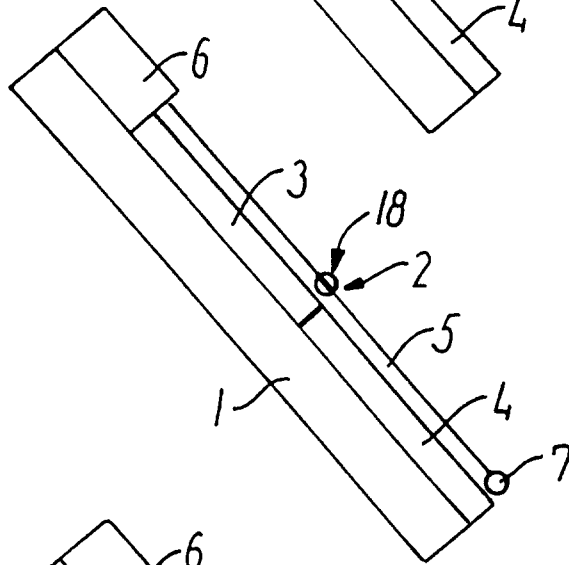

FIG. 5

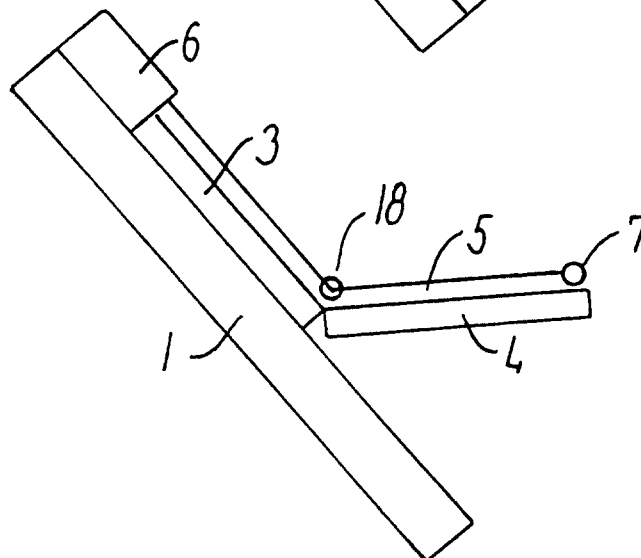

FIG. 6

3/5

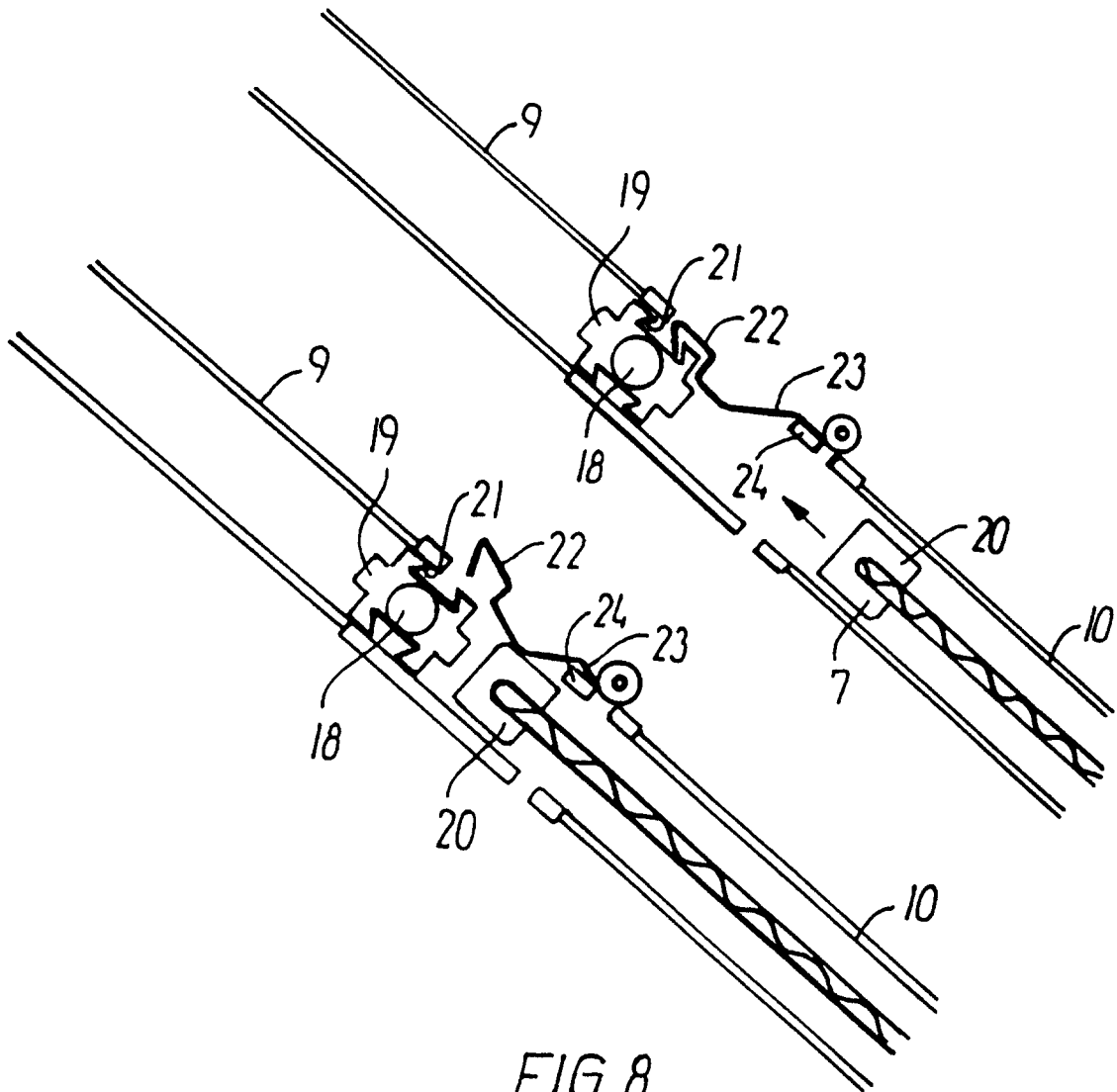

FIG. 8

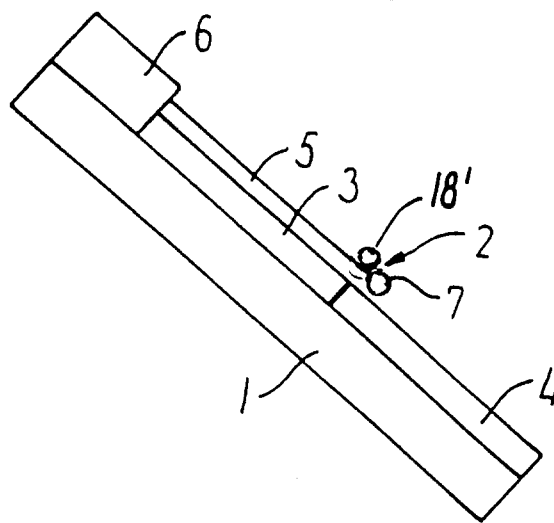

FIG. 7

4/5

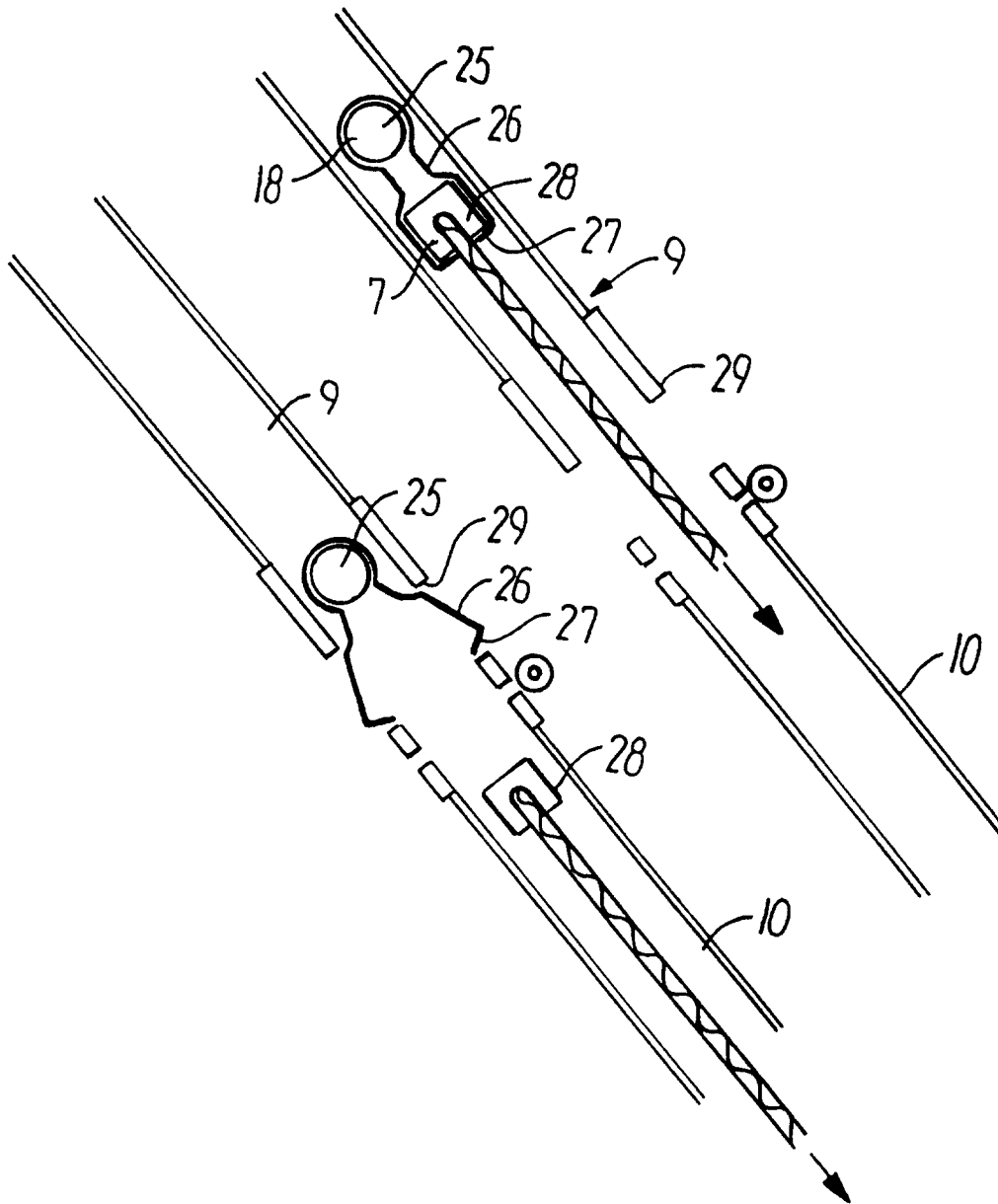

FIG. 9

5/5

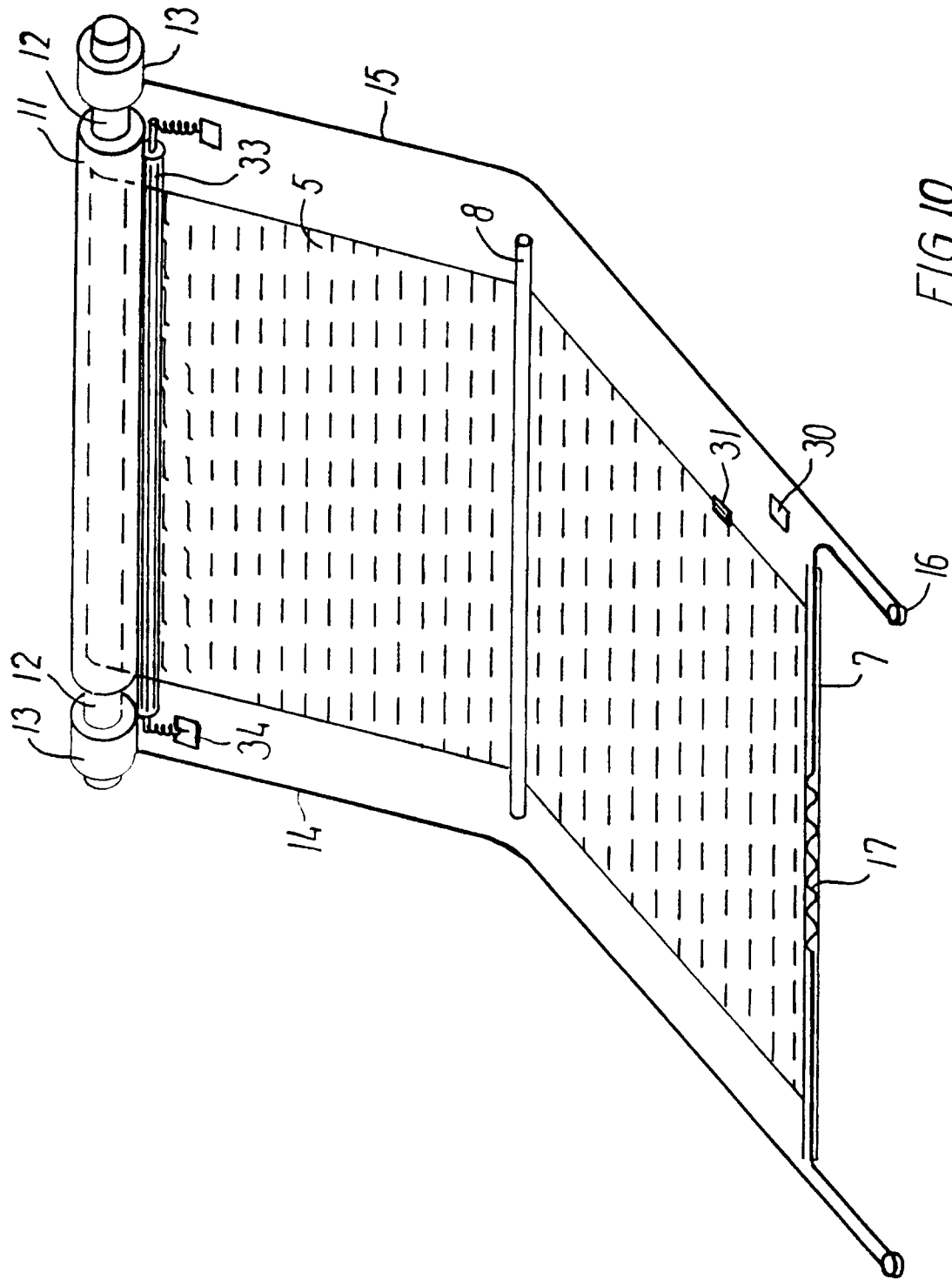

FIG. 10

