

No. 622,841.

Patented Apr. 11, 1899.

L. C. CROWELL.
WRAPPING MACHINE.

(Application filed June 1, 1896.)

(No Model.)

6 Sheets—Sheet 1.

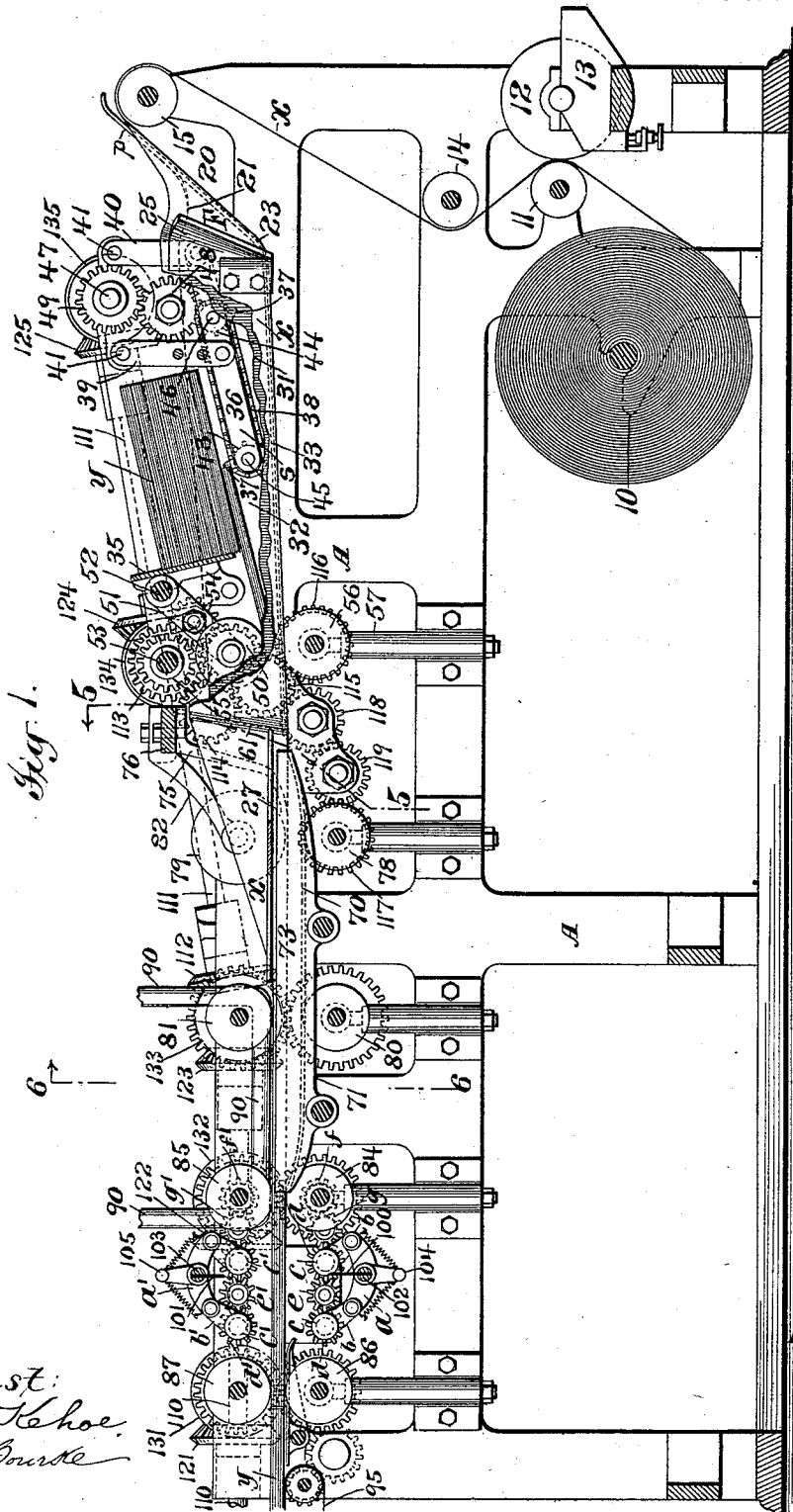

Fig. 1.

6

Attest:
T. F. K. Hoe.
A. W. Bourke

Inventor
Luther C
Crowell
By Philip
Munroe Phelps
Att'y

No. 622,841.

Patented Apr. 11, 1899.

L. C. CROWELL.
WRAPPING MACHINE.

(Application filed June 1, 1896.)

(No Model.)

6 Sheets—Sheet 2.

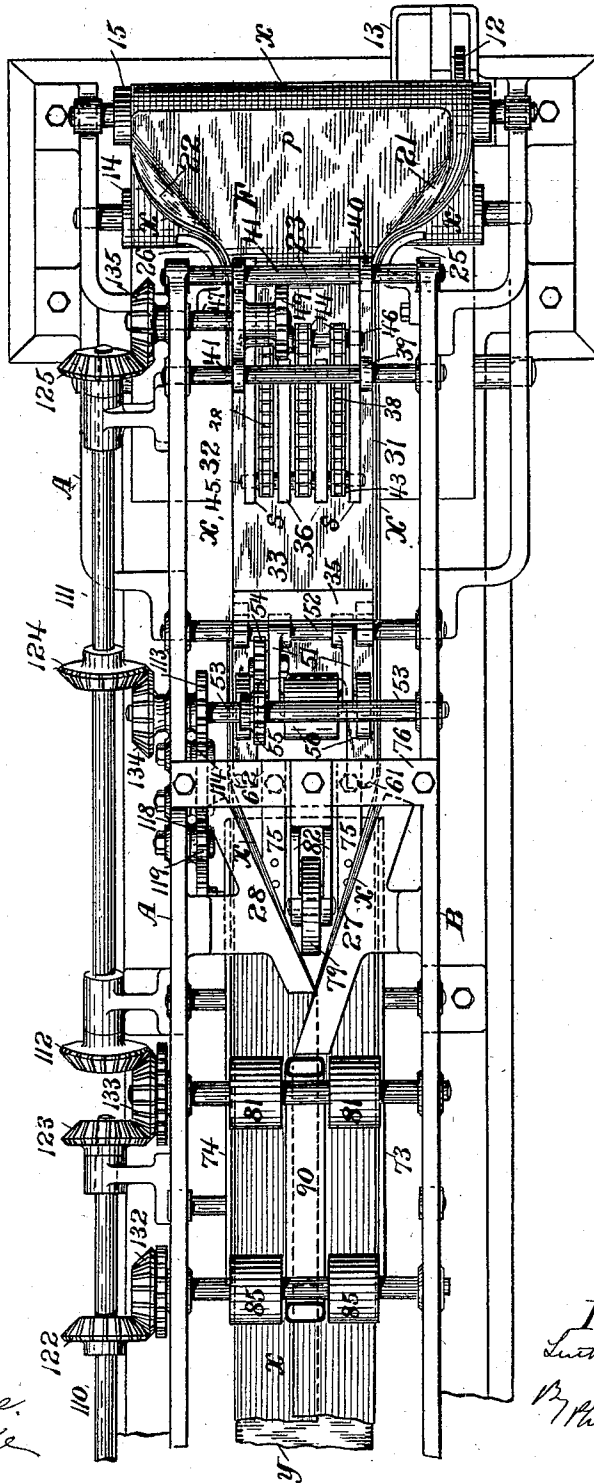

Fig. 2.

Attest:
T. P. Kehoe
A. T. Bouske

Inventor:
Lucien C. Crowell
By *Philippe Monson* *att'ny*

No. 622,841.

Patented Apr. 11, 1899.

L. C. CROWELL.
WRAPPING MACHINE.

(Application filed June 1, 1896.)

(No Model.)

6 Sheets—Sheet 3.

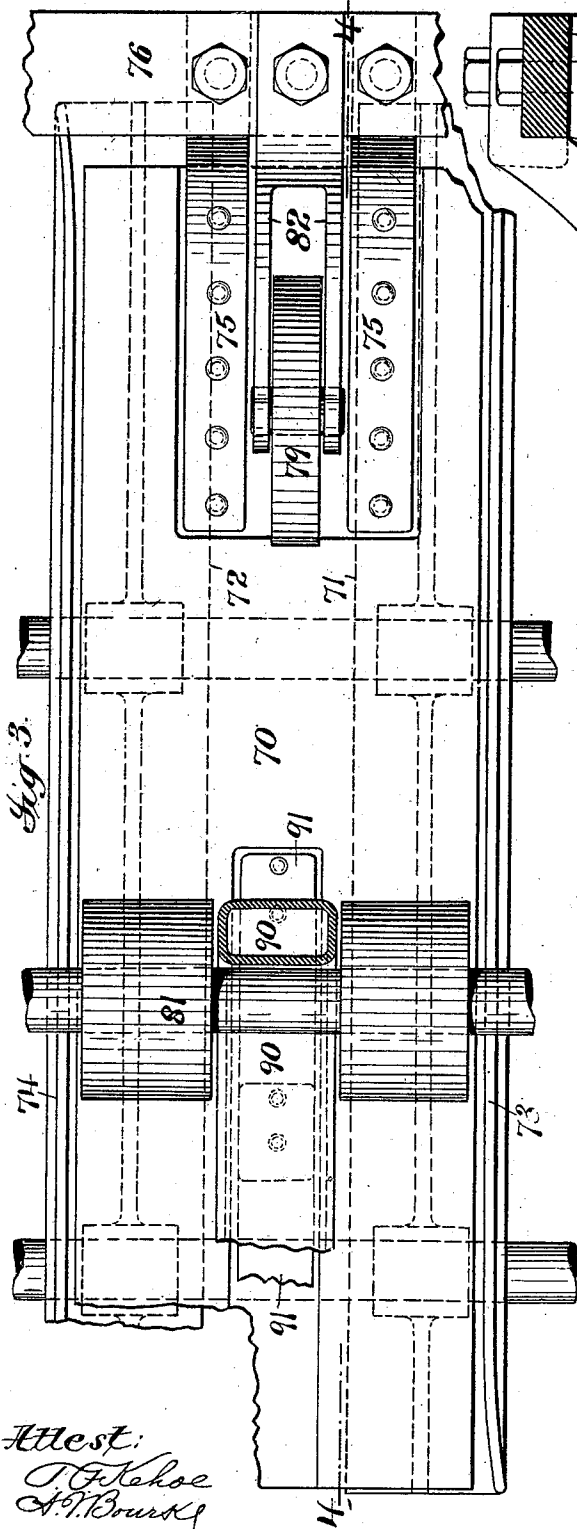

Fig. 3.

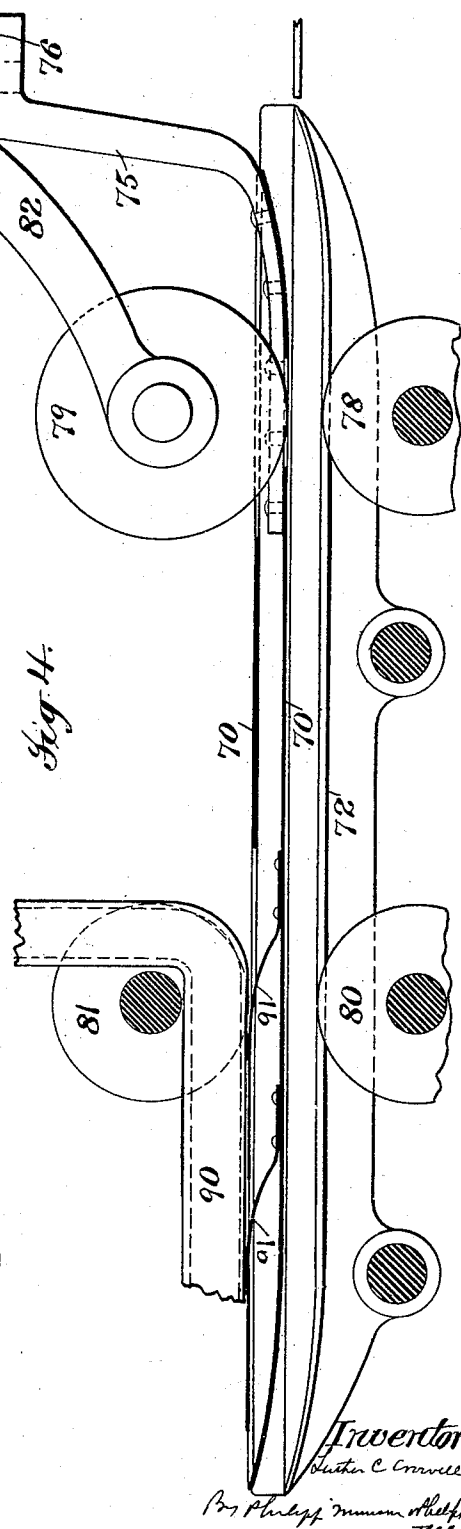

Fig. 4.

Attest:
D. F. Kehoe
A. T. Bourke

Inventor
Lester C. Crowell
By Phelps, Munroe, & Phelps
Attys.

No. 622,841.

Patented Apr. 11, 1899.

L. C. CROWELL.
WRAPPING MACHINE.

(Application filed June 1, 1896.)

(No Model.)

6 Sheets—Sheet 4.

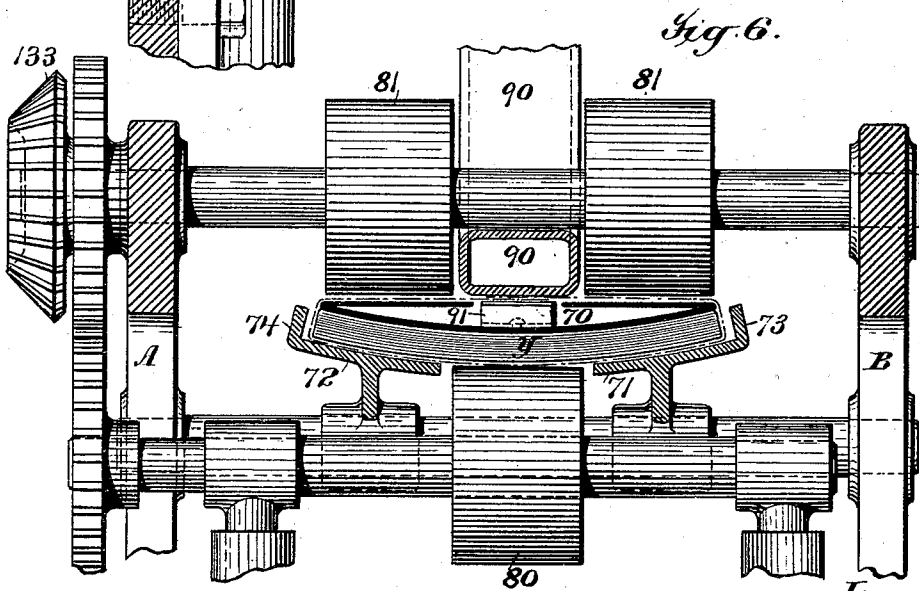
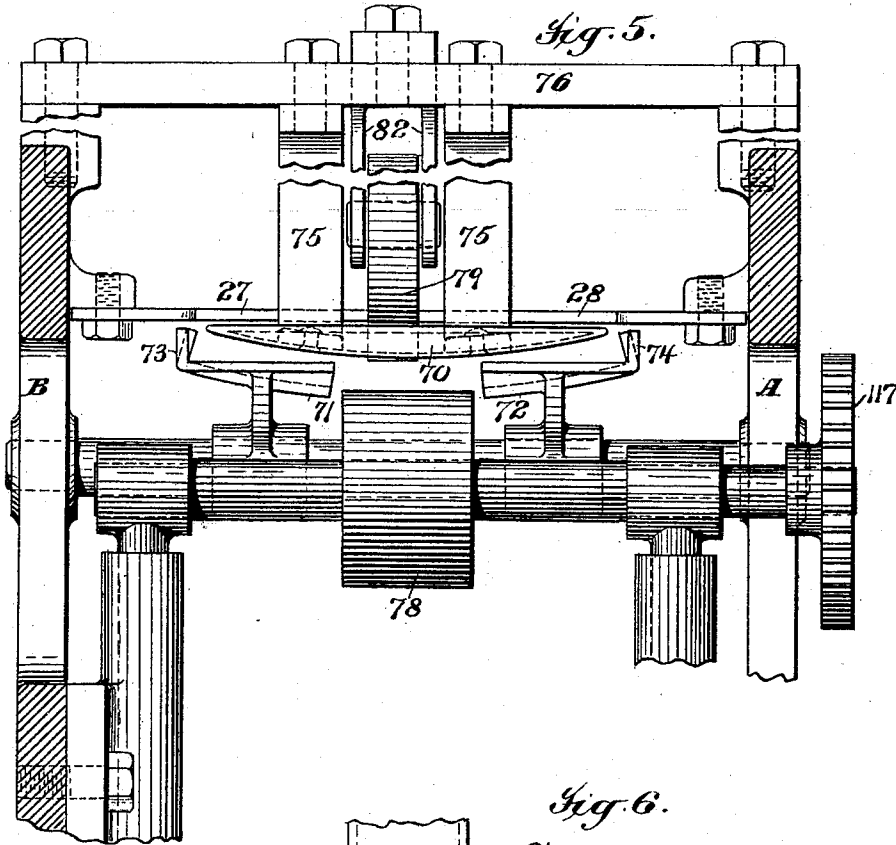

Attest:
T. F. Kehoe.
A. W. Bourke

Inventor:
Luther C. Crowell
By Philip Munson Phelps

Atty

No. 622,841.

Patented Apr. 11, 1899.

L. C. CROWELL.
WRAPPING MACHINE.

(Application filed June 1, 1898.)

(No Model.)

6 Sheets—Sheet 5.

Fig. 7.

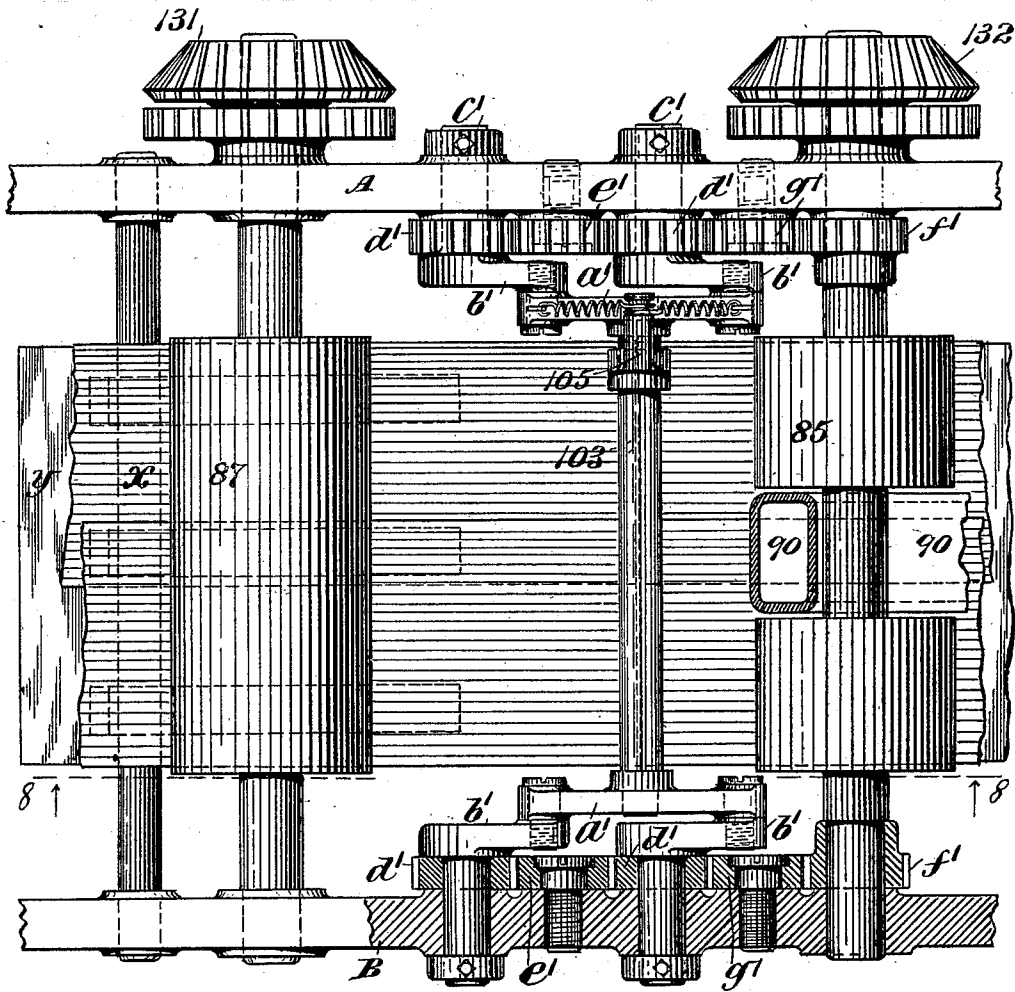

Attest:
J. P. Kase
St. J. Bourke

Inventor
Luther C. Crowell
By Philipp Munson Phelps

Atty's

L. C. CROWELL.
WRAPPING MACHINE.

(Application filed June 1, 1896.)

(No Model.)

6 Sheets—Sheet 6.

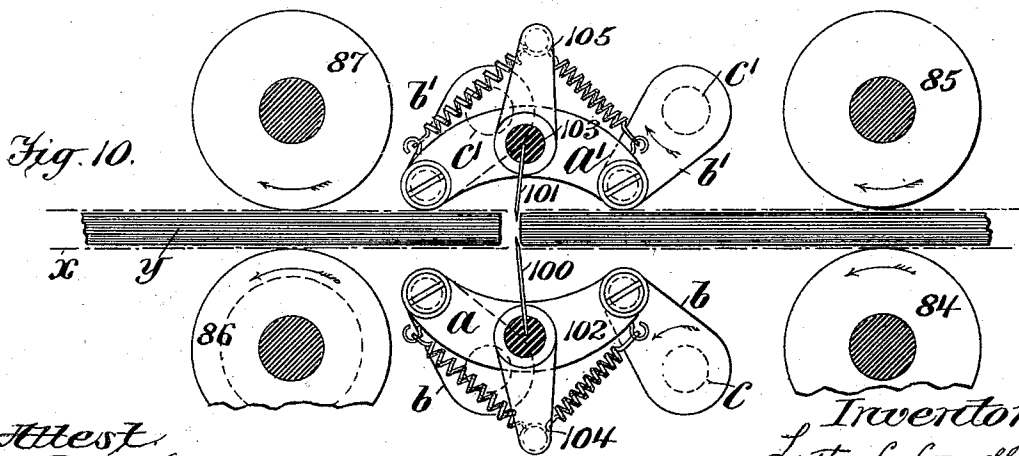
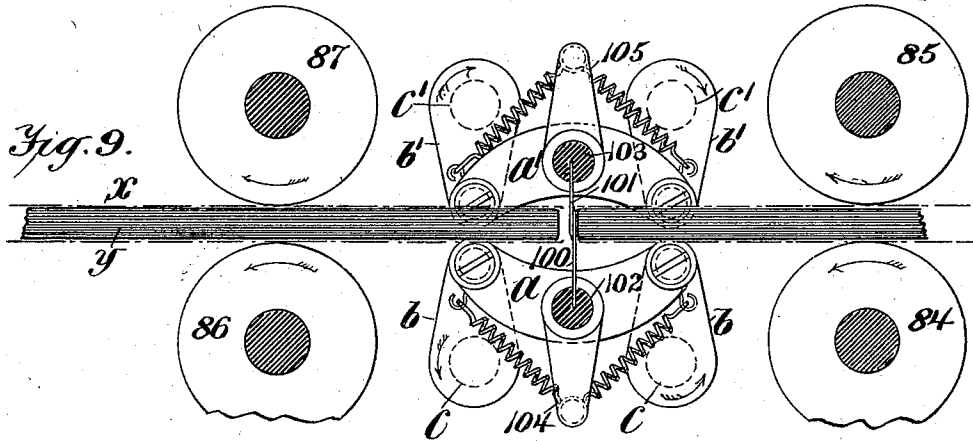
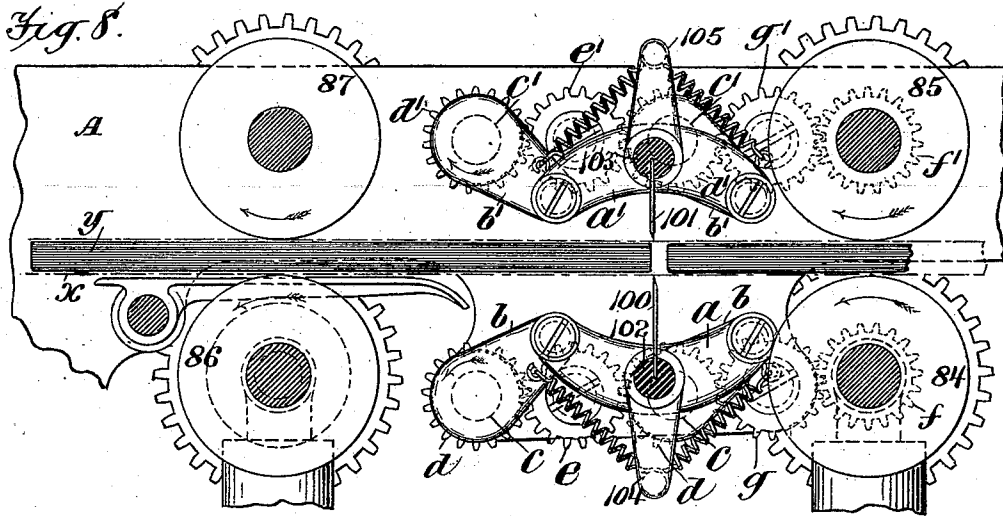

Attest
T. F. Kehoe.
A. W. Bourke

Inventor
Lester C. Crowell
By Philip Munson Welch
Attys

UNITED STATES PATENT OFFICE.

LUTHER C. CROWELL, OF NEW YORK, N. Y., ASSIGNOR TO ROBERT HOE,
THEODORE H. MEAD, AND CHARLES W. CARPENTER, OF SAME PLACE.

WRAPPING-MACHINE.

SPECIFICATION forming part of Letters Patent No. 622,841, dated April 11, 1899.

Application filed June 1, 1896. Serial No. 593,755. (No model.)

To all whom it may concern:

Be it known that I, LUTHER C. CROWELL, a citizen of the United States, residing at New York, (Brooklyn,) county of Kings, and State
5 of New York, have invented certain new and useful Improvements in Wrapping-Machines, fully described and represented in the following specification and the accompanying drawings, forming a part of the same.

10 This invention relates especially to improvements in machines of that class used for applying wrappers to books, magazines, pamphlets, folded newspapers, and similar articles, which articles will be hereinafter called
15 "papers," which term is to be understood as meaning all articles on which a machine embodying the present invention may be found adapted to operate; but such machines are especially designed for use with magazines or
20 other quite thick pamphlets.

More particularly the general features of the invention relate to a wrapping-machine of that class in which the wrapper is folded to form a tube by means of longitudinal fold-
25 ers, the papers being placed in position and advanced with the wrapper before the edges of the wrapper are folded over to complete the tube. In United States Letters Patent No. 516,186, granted to me March 13, 1894, I
30 have described and claimed a machine of this class in which the sides of the wrapper are first bent downwardly and then turned back and folded over upon the paper lying on the middle portion of the wrapper. This reverse
35 folding was for the purpose of causing all parts of the wrapper to travel the same distance, while at the same time providing for the feeding of the papers into position to be enveloped by the wrapper as it is folded
40 to form a tube. One of the objects of the present invention is to avoid this double or reverse folding of the wrapper in forming the tube, and this result is secured by so arranging the parts of the machine that the wrap-
45 per-tube shall be formed merely by folding the sides or edges of the wrapper up and then completing the tube by folding down such up-
50 turned edges, the papers being fed into position to be enveloped by the wrapper as its edges are folded down to complete the wrapper-tube.

In carrying out the invention I preferably provide paper-feeding devices so located and arranged that the wrapper may be advanced with its upturned sides or edges on either side
55 of the feeding devices, and the means for turning up the edges of the wrapper and for completing the folding of the wrapper to form a tube are preferably separated, so as to leave a trough-like space between the upturned
60 edges of the wrapper long enough to accommodate suitable paper holding and feeding devices. By thus feeding the papers in the direction of movement of the wrapper into the
65 trough formed by turning up the edges of the wrapper the papers will be fed forward on the wrapper after the operation of the paper-feeding devices ceases without the danger of slip
70 between the wrapper and paper, which would exist if the wrapper started the movement of the paper from a state of rest, this result being materially aided also by the pressure of
75 the sides of the trough formed by the wrapper upon the side edges of the paper, so that the accurate positioning of the papers longitudinally of the inclosing wrapper is assured,
80 which is of great importance in this class of machines, in which successive papers are wrapped within a tube and the tube then severed between the papers, as a paper out of
85 position longitudinally of the wrapper is liable to be cut by the wrapper-severing mechanism.

This invention includes, further, improved devices for operating, cutting, and similar
85 blades especially adapted for use as a severing mechanism in a machine embodying the other features of the invention, but which may also be used in machines of other classes.

For a full understanding of the invention a detailed description will now be given of a
90 complete wrapping-machine embodying the various features of the invention in a preferred form, reference being had to the accompanying drawings, illustrating such a machine, and the features forming the invention
95 will be afterward specifically pointed out in the claims.

In said drawings, Figure 1 is a side elevation of the machine, the near side of the frame being removed and parts being broken away. 100
Fig. 2 is a partial plan view of the machine as shown in Fig. 1. Fig. 3 is an enlarged plan

view of the paper-bending devices. Fig. 4 is a section taken on line 4 of Fig. 3. Figs. 5 and 6 are enlarged cross-sectional views taken on lines 5 and 6, respectively, of Fig. 1. Fig. 7 is an enlarged plan view of the severing mechanism and adjacent feeding-rolls. Fig. 8 is a section taken on line 8 of Fig. 7, and Figs. 9 and 10 are diagrammatical views showing different positions assumed by the severing mechanism during the process of severing the wrapper-tube between the papers.

Referring to said drawings, the various parts of the machine are supported by side frames A B. The wrapper *x* is drawn from a roll mounted in bearings 10, at the lower rear end of the machine, over a roll 11, where it receives a line of paste near one edge from a paste-disk 12, mounted to rotate in a paste-fountain 13. The wrapper is then led upward past a roll 14 and over a roll 15 in the upper part of the machine, from which it passes downward to a longitudinal folder, by which its sides or edges are turned up to stand at about right angles with its central portion. This folder consists of an internal folder F, consisting of angularly-arranged internal guides or turning edges 21 22 and a horizontal guide or turning edge 23, connecting the lower ends of the guides 21 22, external folders or turners 25 26 being also preferably provided. The edges of the wrapper are turned up about the guides 21 22 by the external turners 25 26, so as to stand at about right angles to the middle portion of the wrapper, which is turned about the horizontal guides 23, so that the now partially-folded wrapper advances in a direction at an angle to that in which it moved before, so that all parts of the wrapper travel practically the same distance, and therefore are held under the same tension, as is well understood to be desirable in the art of folding paper by means of longitudinal folders having angularly-arranged internal guides. The folding of the wrapper to form a tube is completed by a pair of folding-guides 27 28, set at converging angles in a plane parallel with the plane in which the middle portion of the wrapper moves during and after the time at which it is acted upon by said folding-guides; but these horizontal folders 27 and 28 are placed some distance beyond the internal folder F and the external turners 25 and 26, so as to leave space between the point where the edges of the wrapper are folded up and the point where the folding is completed for paper-feeding mechanism for feeding the papers onto the middle portion of the partially-folded wrapper.

The internal folder F is preferably formed of a metal plate *p*, which is bent to form the guides 21 22 23 and is preferably extended beyond the bent edges forming said guides to form the side plates 31 and 32 and bottom plate 33 of a trough or box about which the paper is advanced to the folding-guides 27 and 28 and in and above which are located paper holding and feeding devices constructed

substantially as follows: The papers *y* are supported between the side plates 31 32 and a plate 35, forming the front of the paper-holder thus formed, by a slatted bottom 36, between the slats of which move paper-advancing lugs 37 on endless belts or sprocket-chains 38, by which the papers are fed forward beneath the front plate 35, which is of the proper length to allow one paper at a time to be fed forward beneath it. The two outside slats *s* of the bottom 36 are extended backward and are supported by depending arms 39 40 from cross-bars 41, extending between the sides of the machine above the side plates 31 32, so as to clear the upturned edges of the wrapper as it passes through the machine.

The sprocket-chains 38 turn on sprockets 43 and 44, carried by shafts 45 and 46, respectively journaled in the outside slats *s* of the bottom 36, and are driven from a shaft 47 through an intermediate 48, meshing with a gear 49 on the shaft 47 and with a gear on the sprocket-shaft 46. The slats forming the bottom 36 are set at an angle to the bottom plate, and for the sake of economizing space preferably extend only a little past the middle of the length of the papers as they lie in the holder, the sprocket-shaft 45 being mounted near the forward end of the bottom.

As the paper is fed forward from the paper-holder its forward end drops to the bottom plate 33 and on its farther forward movement is engaged by a feeding-roll 50, which is carried by arms 51, depending from a cross-bar 52, extending between the side frames of the machine above the side plates 31 and 32, so as to clear the upturned edges of the wrapper, and which roll is driven from a transverse shaft 53 through an intermediate 54 on a stud carried by one of the arms 51 and meshing with a gear 55 on said shaft and with a gear on the shaft of the roll 50. The shaft 53 is journaled in the side frames and extends across the machine above the side plates 31 and 32 and the upturned edges of the wrapper. A feeding and supporting roll 56, carried by a shaft journaled in brackets 57, mounted at either side of the machine, coacts with the roll 50 from beneath, the bottom plate being cut away, as shown, so that the paper comes directly in contact with the middle portion of the wrapper at this point, and the papers and wrapper are fed forward by means of these rolls 50 and 56, bearing respectively against the upper side of the paper and the under side of the wrapper. Then as the wrapper is farther advanced through the machine with the papers placed successively in position over its middle portion the folding of the wrapper to form the wrapper-tube is completed, the edges of the wrapper being turned down over the papers by means of the horizontal folding-guides 27 and 28.

The side plates 31 and 32 terminate just in the rear of the folding-guides 27 and 28, the ends of the plates forming internal supporting and bearing guides or edges 61 62 for the

wrapper as it is turned inward and downward by the guides 27 and 28. The ends of the plates are preferably turned or rounded slightly inward, so as to provide rounded bearing-guides, as shown in Fig. 2. From the point where this second part of the folding operation begins the wrapper is advanced in a direction at a slight angle to that in which it moved beneath the bottom plate 33, this angle and the angle at which the horizontal guides 27 and 28 are set and the inclination of the internal guiding edges 61 and 62 being relatively such that each part of the wrapper will travel the same distance.

For the purpose of securing a tight fit of the wrapper about the paper there is preferably provided a suitable conforming device for bending the paper transversely at the time the wrapper-tube is being formed about it, so that the distance around the paper at that time will be slightly less than the distance around it when it is in a flat position. For this purpose there is provided in the machine illustrated in the drawings a float 70, having its upper surface plane and its lower surface curved transversely, so that it shall be plano-convex in cross-section, the bottom surface of the float being also tapered upward at each end. The papers as they are advanced upon the middle portion of the wrapper pass beneath this float, while the edges of the wrapper are turned down upon the upper surface thereof, and the paper is bent up at its edges, so as to conform to the curved under surface of the float, by means of guides 71 72 at either side, which guides are preferably curved to correspond with the curve of the under surface of the float and provided with upwardly-extending edge-guiding side flanges 73 74. The float 70 is supported at its rear end by depending arms 75 from a cross-bar 76, extending between the side frames A B above the upturned edges of the wrapper.

Feeding-rolls 78 80 engage the under side of the middle portion of the wrapper between the guides 71 72. A feeding-roll 79, carried by depending arms 82 from the cross-bar 76, coacts with the feeding-roll 78, acting, through an opening in the float 70, to engage the upper surface of the papers as they are advanced beneath the forward end of the float, and a feeding-roll 81 engages the upper surface of the edges of the wrapper after they have been turned down over the float.

As the wrapper-tube, with the inclosed papers, advances beyond the conforming device it is engaged by a pair of feeding and pressing rolls 84 and 85, by which the papers are flattened, which causes the wrapper-tube to be drawn tightly about the papers. A pair of final feeding and pressing and delivery rolls 86 and 87 are preferably provided beyond the rolls 84 85, suitable severing mechanism being preferably provided to sever the wrapper-tube between the successive papers as they are advanced from the rolls 84 85 to the rolls 86 87.

As the pasted seam of the wrapper is subjected to a considerable strain by the flattening out of the papers by the rolls 86 and 87, I preferably provide means for drying the seam while the paper is still in its bent position, thereby avoiding the necessity of lengthening the bending or conforming device to such an extent as would otherwise be necessary to allow the seam to dry sufficiently to withstand such a strain before the papers are flattened. For this purpose there is provided in the preferred construction shown a steam-pipe 90, having a flattened surface extending for a sufficient distance just above the float beyond the folders 27 and 28 to cause a sufficient drying of the pasted seam as it is advanced beneath and in contact therewith. This drying-pipe preferably extends down around the rear side of the shaft of the roll 81, then forward beneath said shaft, and up in front of the shaft of the roll 85, the rolls 81 and 85 being cut away, as shown in Fig. 3, to accommodate said pipe. In order that the seam of the wrapper may be held in contact with the under surface of the steam-pipe as the wrapper is advanced beneath it, the upper surface of the float 70 is cut away beneath the steam-pipe and one or more springs 91 are provided to bear against the under side of the wrapper-seam, which springs hold the seam against the under side of the pipe without causing unnecessary friction between the wrapper and steam-pipe, by which the movement of the wrapper would be retarded. The steam-pipe 90 may be connected by any suitable connections with a suitable steam-supply.

The machine is preferably provided with means for cutting the wrapper-tube between the successive papers as the tube, with its inclosed papers, is advanced from the wrapping devices. Any suitable severing device may be employed for this purpose. I have shown a convenient form of severing mechanism, which in itself constitutes a feature of the invention and which in the preferred form is constructed substantially as follows:

Coacting severing-blades 100 and 101 are carried by shafts 102 and 103, respectively, one above and one below the line of movement of the wrapped papers. The shaft 102 is carried by brackets or carriers *a a* at either side of the machine. The carriers *a* are each carried by two equal and parallel crank-arms *b*, each of which crank-arms *b* is carried by a stud *c*, journaled in the side frame of the machine, and each of which studs is provided with a gear *d*. Intermediates *e* connect the gears *d* of each pair of studs *c*, and each pair of studs is driven from a gear *f* on the shaft of the roll 84 through an intermediate *g*, meshing with one of the gears *d* of each pair, whereby the cranks *b*, carrying the brackets *a*, are caused to rotate in unison. The carriers *a a* and the severing-blade 100, carried thereby, are given a rotary movement of constant parallelism, being moved through a cir-

ular path and occupying at all periods of their
 movement positions parallel with the position
 they occupy at any period. The severing-
 blade is therefore, in the machine shown, main-
 5 tained constantly in a vertical position while
 being moved through a course which carries it
 into the path of the horizontally-moving pap-
 ers. Similarly the shaft 103 is carried by
 brackets or carriers $a' a'$ at either side of the
 10 machine, and these carriers are each carried
 by two equal and parallel crank-arms b' , each
 of which crank-arms b' is carried by a stud c' ,
 journaled in the side frame of the machine,
 and each of which studs is provided with a
 15 gear d' . Intermediates e' connect the gears
 d' of each pair of studs c' , and each pair of
 studs is driven from a gear f' on the shaft of
 the roll 85 through an intermediate g' , mesh-
 ing with one of the gears d' of each pair. It
 20 will thus be seen that the cranks carrying the
 carriers $a a$ and $a' a'$ being caused to rotate
 in the proper directions, as indicated by ar-
 rows in Figs. 8 to 10, and at the proper speed
 the severing-blades 100 and 101 will be given
 25 a circular movement, whereby when they
 are approaching each other they will move in
 the same direction and at about the same
 speed as the wrapped paper; but as this lon-
 gitudinal movement of the blades is not ex-
 30 actly uniform it cannot be made to corre-
 spond exactly with the movement of the pap-
 ers, and especially with quite thick papers
 the cutting-blades may bind upon the end of
 the paper in advance of the blades or that be-
 35 hind the blades, according to the relative
 speeds of the blades and papers. The blades
 are therefore preferably mounted so that
 they may have a slight movement longitudi-
 nally of the movement of the papers against
 40 a yielding tension by which they are held in
 their normal positions. For this purpose the
 shafts 102 103 are preferably pivotally mount-
 ed in their carrying-brackets $a a$ and $a' a'$,
 respectively, and are held so as to maintain
 45 the blades in their normal vertical positions,
 preferably by means of centering-springs 91,
 extending in either direction from arms 104
 and 105 on the shafts 102 and 103, respec-
 tively, to the brackets a and a' , respectively.
 50 The severing-blades are thus free to yield
 slightly if struck by the end of the paper.

The action of the severing-blades con-
 structed as above described will be readily
 understood by reference to Figs. 8, 9, and 10,
 55 Fig. 8 showing the position of the severing-
 blades and their supporting parts as the
 blades are just coming in contact with the
 wrapper-tube between two successive papers,
 Fig. 9 showing the position of the parts when
 60 the blades have been advanced to the full ex-
 tent of their movement toward each other and
 have completely severed the wrapper-tube,
 and Fig. 10 showing the blades as they are
 being withdrawn from between the papers
 65 after having severed the wrapper by the con-
 tinued rotation of the carrying crank-arms
 and showing the blades as moved slightly out

of their normal vertical positions by the for-
 ward end of one of the papers on account of
 the horizontal or longitudinal movement of 70
 the blades at this point being less than that
 of the papers.

It is evident that the means for securing
 the desired movement of the severing-blades,
 as above described, may vary greatly from 75
 that shown. Thus instead of the blades be-
 ing mounted in brackets which are each car-
 ried by two equal and parallel crank-arms,
 as in the construction shown, they may be ro-
 tatably mounted in single crank-arms or in a 80
 cylinder and controlled by suitable gears to
 maintain them in positions of constant par-
 allelism during their movement of rotation
 in the manner well understood for obtaining
 the desired rotary movement of constant par- 85
 allelism. It is to be understood, therefore,
 that any other suitable means than that shown
 may be used for securing the desired move-
 ment of the severing-blades. The means
 shown, however, is preferred and in itself 90
 forms a feature of the invention.

The wrapped and severed papers may be
 delivered by the rolls 86 and 87 to any suit-
 able receptacle or onto a suitably-arranged
 carrying-belt, by which they may be carried 95
 to a convenient receptacle. I have shown
 them as being delivered upon such a carry-
 ing-belt 95.

The various moving parts of the machine
 are driven from a longitudinally-arranged 100
 driving-shaft 110, said shaft carrying be-
 veled gears 121 122 123, engaging beveled gears
 131 132 133 on the ends of the shafts of the
 rolls 87 85 81, respectively. The shafts of
 the rolls 86, 84, and 80 carry gears meshing 105
 with gears on the shafts of the rolls 87,
 85, and 81, respectively. The shafts 53 and
 47 are driven from an inclined longitudinal
 shaft 111, carrying beveled gears 124 and
 125, engaging beveled gears 134 and 135 on 110
 the ends of said shafts, said shaft 111 being
 driven from the shaft 110 through beveled
 gears 123, 133, and 112. The shaft of the roll
 56 is driven from a gear 113 on the trans- 115
 verse shaft 53, through intermediates 114 and
 115, the gear 115 meshing with a gear 116 on
 the shaft of the roll 56, and the shaft of the
 roll 78 carries a gear 117 and is driven from
 the gear 113 on the shaft 53, through the
 train of gears 114, 115, 118, and 119. 120

It will be understood that many modifica-
 tions may be made in the construction shown
 without departing from the invention and
 that the various features of the invention may
 be embodied in machines differing widely in 125
 construction and method of operation from
 that shown.

My improved severing mechanism may be
 employed wherever it is desired to cut mov- 130
 ing tubes or other papers or bodies, being es-
 pecially useful where it is necessary to cut
 through a considerable distance, as in the
 case of severing a wrapping-tube between the
 articles wrapped. Certain features of this

mechanism may be used also with blades used for other purposes than cutting, such as folding-blades and tucking-blades, and it will be understood that the claims which are not limited to any particular class of blades are intended to cover such uses.

By the phrase "rotary movement of constant parallelism" used in the claims to define the movement of the severing-blades I mean that the severing-blade is moved through a circular path while occupying at all periods of its movement positions substantially parallel with its original positions or remaining constantly parallel with a given plane.

What I claim is—

1. The combination of means for turning the edges of a wrapper up to form a trough, means for folding the upturned edges of the wrapper down to complete the wrapper-tube, and feeding devices located between the paths of the upturned edges of the wrapper for feeding the articles to be wrapped in the direction of the movement of the wrapper onto the middle portion of the wrapper, substantially as described.

2. The combination of means for turning the edges of a wrapper up to form a trough, means for folding the upturned edges of the wrapper down to complete the wrapper-tube, and feeding devices for the articles to be wrapped located between the paths of the upturned edges of the wrapper consisting of a holder and means for advancing the articles successively from the holder in the direction of the movement of the wrapper onto the middle portion of the wrapper, substantially as described.

3. The combination of means for turning the edges of a wrapper up to form a trough, means for folding the upturned edges of the wrapper down to complete the wrapper-tube, feeding devices for the articles to be wrapped located between the paths of the upturned edges of the wrapper consisting of a holder, means for advancing the articles successively from the holder onto the middle portion of the wrapper, and a feeding-roll 50, substantially as described.

4. The combination of means for turning the edges of a wrapper up to form a trough, means for folding the upturned edges of the wrapper down to complete the wrapper-tube, means for feeding articles to be wrapped successively onto the middle portion of the wrapper, and a feeding-roll 50 between the paths of the upturned edges of the wrapper, substantially as described.

5. The combination of an internal folder F having converging guides 21 and 22 and a horizontal guide 23, and external turners, whereby the edges of a wrapper are turned up to form a trough, longitudinal folders 27 and 28 by which the upturned edges of the wrapper are folded down to complete the wrapper-tube, and feeding mechanism for the articles to be wrapped located between the in-

ternal folder F and the folders 27 and 28, substantially as described.

6. The combination of an internal folder F formed of a metal plate bent to form converging guides 21 and 22 and a horizontal guide 23 and extended beyond the guides 21, 22 and 23 to form the side plates 31 and 32 and the bottom plate 33 respectively, and longitudinal folders 27 and 28 beyond the side plates 31 and 32, substantially as described.

7. The combination of means for turning the edges of a wrapper up to form a trough, longitudinal folders 27 and 28 by which the upturned edges of the wrapper are folded down to complete the wrapper-tube, and a feeding-roll 50 engaging the upper surface of the articles to be wrapped as they are advanced between the upturned edges of the wrapper to the longitudinal folders, substantially as described.

8. The combination of means for turning the edges of a wrapper up to form a trough, longitudinal folders 27 and 28 by which the upturned edges of the wrapper are folded down, to complete the wrapper-tube, a feeding-roll 50 engaging the upper surface of the articles to be wrapped as they are advanced between the upturned edges of the wrapper to the longitudinal folders, and a roll 56 contacting with the roll 50, substantially as described.

9. The combination with an internal folder F having converging guides 21 and 22 and a horizontal guide 23, external turners 25 and 26, and longitudinal folders 27 and 28, of side plates 31 and 32 and a bottom plate 33 between the internal folder F and the folders 27 and 28, and a feeding and supporting roll 56, substantially as described.

10. The combination with an internal folder F having converging guides 21 and 22 and a horizontal guide 23, external turners 25 and 26, and longitudinal folders 27 and 28, of side plates 31 and 32 between the internal folder F and the folders 27 and 28, and feeding mechanism for the articles to be wrapped located between said side plates, substantially as described.

11. The combination with an internal folder F having converging guides 21 and 22 and a horizontal guide 23, external turners 25 and 26, and longitudinal folders 27 and 28, of side plates 31 and 32 between the internal folder F and the folders 27 and 28, a holder for the article to be wrapped formed by the said side plates and a front plate 35 and a slatted bottom 36 supported by depending arms 39, 40, advancing lugs carried by sprocket-chains moving between the slats of said bottom and turning on sprocket-wheels journaled in said bottom, and a feeding-roll 50, substantially as described.

12. The combination with an internal folder F having converging guides 21 and 22 and a horizontal guide 23, external turners 25 and 26, and longitudinal folders 27 and 28, of side plates 31 and 32 between the internal folder

- F and the folders 27 and 28, a holder for the articles to be wrapped formed by said plates and a front plate 35, and means for advancing the articles successively from the holder, substantially as described.
13. The combination with longitudinal folding devices for folding a wrapper to form a tube about the article to be wrapped, of means for bending the article transversely while the edges of the wrapper are folded to overlap thereon and secured by paste, and means for drying the pasted seam of the wrapper while the article is still bent, substantially as described.
14. The combination with longitudinal folding devices for folding a wrapper to form a tube about the article to be wrapped, the edges of the wrapper being overlapped upon one side of the article and secured by paste, of means for bending the article transversely during the folding of the wrapper so that the wrapper-seam shall be formed on the concave side of the article and means for drying the wrapper-seam while the article is still bent, substantially as described.
15. The combination with longitudinal folding devices for folding a wrapper to form a tube about the article to be wrapped, of a longitudinal float 70 having a plane upper surface and a transversely-convex lower surface, and guides 71 and 72, whereby the article is bent transversely while the edges of the wrapper are folded to overlap above the float 70 and secured by paste, a drying-surface above the float beyond the point where the folding of the wrapper is completed, and springs 91 whereby the wrapper-seam is held in contact with the drying-surface, substantially as described.
16. The combination with longitudinal folding devices for folding a wrapper to form a tube about the article to be wrapped, of a longitudinal float 70 and guides 71 and 72, whereby the article is bent transversely while the edges of the wrapper are folded to overlap above the float 70 and secured by paste, and a steam drying-pipe above the float beyond the point where the folding of the wrapper is completed, substantially as described.
17. The combination with longitudinal folding devices for folding a wrapper to form a tube about the article to be wrapped, of a longitudinal float 70 and guides 71 and 72, whereby the article is bent transversely while the edges of the wrapper are folded to overlap above the float 70 and secured by paste, a steam drying-pipe above the float beyond the point where the folding of the wrapper is completed, springs 91 whereby the wrapper-seam is held in contact with the steam-pipe and a pair of feeding and pressing rolls whereby the wrapped article is flattened, substantially as described.
18. The combination with feeding devices for advancing a wrapper-tube with articles therein longitudinally of the wrapper-tube, of coacting transverse severing-blades, and means for giving said blades opposite rotary movements of constant parallelism, substantially as described.
19. The combination with feeding devices therein longitudinally of the wrapper-tube, of coacting transverse severing-blades, carriers for said blades, each of said carriers being pivotally mounted on crank-arms, and means for rotating said crank-arms, the crank-arms carrying the carriers for the two blades being respectively rotated in opposite directions, substantially as described.
20. The combination with feeding devices for advancing a wrapper-tube with articles therein longitudinally of the wrapper-tube, of coacting transverse severing-blades mounted in carriers and held under yielding tension against movement longitudinally of the movement of the wrapper-tube, and means for giving the carriers for the two blades respectively opposite rotary movements of constant parallelism, substantially as described.
21. The combination with feeding devices for advancing a wrapper-tube with articles therein longitudinally of the wrapper-tube, of coacting transverse severing-blades, carriers *a*, *a*, and *a'*, *a'* for said blades, each of said carriers being pivotally mounted on crank-arms, and means for rotating said crank-arms, the crank-arms carrying the carriers *a*, *a* and those carrying the carriers *a'*, *a'* being rotated respectively in opposite directions, substantially as described.
22. The combination of coacting cutting-blades, and means for giving said blades opposite rotary movements of constant parallelism, whereby the blades are caused to move in the direction of the movement of the article to be cut during the cutting operation, substantially as described.
23. The combination of coacting transverse cutting-blades, carriers for said blades, each of said carriers being pivotally mounted on crank-arms, and means for rotating said crank-arms, the crank-arms carrying the carriers for the two blades being respectively rotated in opposite directions, substantially as described.
24. The combination of coacting blades mounted in carriers and held under yielding tension against movement longitudinally of the movement of the material to be acted on, and means for giving the carriers for the two blades respectively opposite rotary movements of constant parallelism, substantially as described.
25. The combination of a blade mounted in a carrier and held under yielding tension against movement longitudinally of the movement of the material to be acted upon, and means for giving the carrier a rotary movement of constant parallelism, substantially as described.
26. The combination of a blade, a carrier in which said blade is pivotally mounted, crank-arms in which said carrier is pivoted, center-

ing-springs for said blade, and means for rotating said crank-arms, substantially as described.

5 27. The combination of a blade, a carrier in which said blade is pivotally mounted, crank-arms in which said carrier is pivoted, and means for rotating said crank-arms, substantially as described.

10 28. The combination of a transverse severing-blade, carriers in which said blade is pivotally mounted, each of said carriers being pivotally mounted on two equal and parallel crank-arms, centering-springs 19 for said blade, and means for rotating said crank-arms in unison, substantially as described.

15 29. The combination of the internal folder F having converging guides 21 and 22 and a horizontal guide 23, external turners 25 and 26, longitudinal folders 27 and 28, and internal guides 61 and 62, substantially as described.

20 30. The combination of side plates 31 and 32, means for turning the edges of the sheet to be folded up against said side plates, internal guides 61 and 62 formed by the ends of said side plates, and longitudinal folders 27 and 28, substantially as described.

31. The combination of the float 70, longitudinal folders 27 and 28, and feeding-disk 79 acting through an opening in said float between said folders 27 and 28, substantially as described. 30

32. The combination of the float 70 having a plane upper surface and a transversely-curved under surface, guides 71 and 72, feeding-disk 79 acting through an opening in the float 70, and feeding-roll 78 coacting with the disk 79 between the guides 71 and 72, substantially as described. 35

33. The combination with means for bending articles transversely while a wrapper-tube is being formed about them, of steam-pipe 90, and feeding-rolls 81 and 85 cut away to accommodate the pipe 90 and engaging the wrapper on either side of said pipe, substantially as described. 40 45

In testimony whereof I have hereunto set my hand in the presence of two subscribing witnesses.

LUTHER C. CROWELL.

Witnesses:

C. J. SAWYER,
T. F. KEHOE.