



(51) International Patent Classification:

A61B 17/16 (2006.01) A61B 18/18 (2006.01)  
A61B 17/17 (2006.01)

(21) International Application Number:

PCT/US2020/050249

(22) International Filing Date:

10 September 2020 (10.09.2020)

(25) Filing Language:

English

(26) Publication Language:

English

(30) Priority Data:

62/899,622 12 September 2019 (12.09.2019) US

(71) Applicant: **RELIEVANT MEDSYSTEMS, INC.**  
[US/US]; 8500 Normandale Lake Blvd., Suite 2150, Minneapolis, MN 55437-3833 (US).

(72) Inventors: **DONOVAN, Brian, W.**; 8500 Normandale Lake Blvd., Suite 2150, Minneapolis, MN 55437-3833

(US). **PATEL, Samit**; 8500 Normandale Lake Blvd., Suite 2150, Minneapolis, MN 55437-3833 (US). **BAKER, Ray, M.**; 8500 Normandale Lake Blvd., Suite 2150, Minneapolis, MN 55437-3833 (US). **MARKS, Michael, R.**; 8500 Normandale Lake Blvd., Suite 2150, Minneapolis, MN 55437-3833 (US). **EDIDIN, Avram, Allan**; 805 La Mesa Dr., Portola Valley, CA 94028 (US). **DINELLO, Alexander, M.**; 55 Forsyth Ct., Cotuit, MA 02635 (US). **PRUITT, Alexander**; 8500 Normandale Lake Blvd., Suite 2150, Minneapolis, MN 55437-3833 (US). **WILLINK, Michael**; 8500 Normandale Lake Blvd., Suite 2150, Minneapolis, MN 55437-3833 (US).

(74) Agent: **CHRISTENSEN, Michael, R.**; Knobbe, Martens, Olson & Bear, LLP, 2040 Main Street, 14th Floor, Irvine, CA 92614 (US).

(81) Designated States (unless otherwise indicated, for every kind of national protection available): AE, AG, AL, AM, AO, AT, AU, AZ, BA, BB, BG, BH, BN, BR, BW, BY, BZ, CA, CH, CL, CN, CO, CR, CU, CZ, DE, DJ, DK, DM, DO,

(54) Title: SYSTEMS AND METHODS FOR TISSUE MODULATION

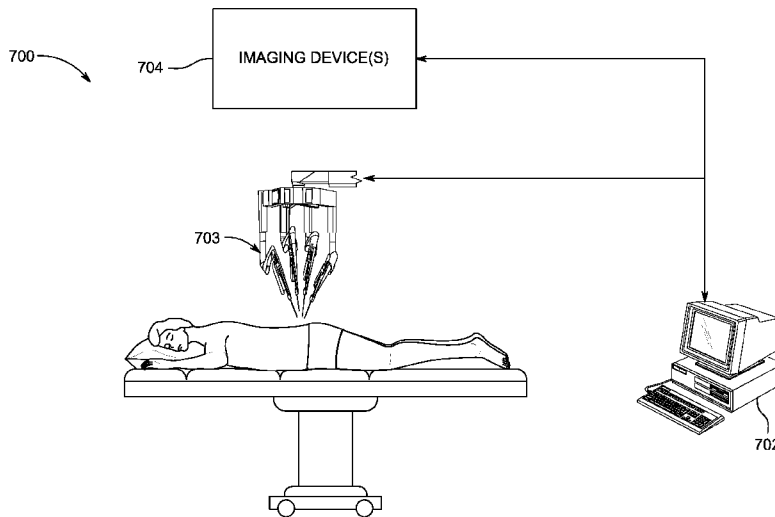
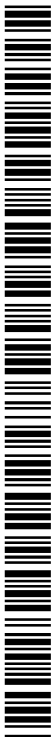

FIGURE 7

(57) Abstract: Described herein are various implementations of systems and methods for accessing and modulating tissue (for example, systems and methods for accessing and ablating nerves or other tissue within or surrounding a vertebral body to treat chronic lower back pain). Assessment of vertebral endplate degeneration or defects (e.g., pre-Modic changes) to facilitate identification of treatment sites and protocols are also provided in several embodiments. Several embodiments comprise the use of biomarkers to confirm or otherwise assess ablation, pain relief, efficacy of treatment, etc. Some embodiments include robotic elements for, as an example, facilitating robotically controlled access, navigation, imaging, and/or treatment.



DZ, EC, EE, EG, ES, FI, GB, GD, GE, GH, GM, GT, HN, HR, HU, ID, IL, IN, IR, IS, IT, JO, JP, KE, KG, KH, KN, KP, KR, KW, KZ, LA, LC, LK, LR, LS, LU, LY, MA, MD, ME, MG, MK, MN, MW, MX, MY, MZ, NA, NG, NI, NO, NZ, OM, PA, PE, PG, PH, PL, PT, QA, RO, RS, RU, RW, SA, SC, SD, SE, SG, SK, SL, ST, SV, SY, TH, TJ, TM, TN, TR, TT, TZ, UA, UG, US, UZ, VC, VN, WS, ZA, ZM, ZW.

**(84) Designated States** (*unless otherwise indicated, for every kind of regional protection available*): ARIPO (BW, GH, GM, KE, LR, LS, MW, MZ, NA, RW, SD, SL, ST, SZ, TZ, UG, ZM, ZW), Eurasian (AM, AZ, BY, KG, KZ, RU, TJ, TM), European (AL, AT, BE, BG, CH, CY, CZ, DE, DK, EE, ES, FI, FR, GB, GR, HR, HU, IE, IS, IT, LT, LU, LV, MC, MK, MT, NL, NO, PL, PT, RO, RS, SE, SI, SK, SM, TR), OAPI (BF, BJ, CF, CG, CI, CM, GA, GN, GQ, GW, KM, ML, MR, NE, SN, TD, TG).

**Declarations under Rule 4.17:**

- *as to applicant's entitlement to apply for and be granted a patent (Rule 4.17(ii))*
- *as to the applicant's entitlement to claim the priority of the earlier application (Rule 4.17(iii))*

**Published:**

- *with international search report (Art. 21(3))*
- *before the expiration of the time limit for amending the claims and to be republished in the event of receipt of amendments (Rule 48.2(h))*

## SYSTEMS AND METHODS FOR TISSUE MODULATION

### RELATED APPLICATIONS

[0001] This application claims priority to US Provisional Application No. 62/899,622 filed September 12, 2019, the entire content of which is hereby incorporated by reference herein.

### FIELD

[0002] Described herein are various implementations of systems and methods for modulating tissue (for example, systems and methods for ablating nerves or other tissue within or surrounding a vertebral body to treat chronic lower back pain). Several embodiments comprise the use of biomarkers to confirm or otherwise assess ablation, pain relief, efficacy of treatment, etc. Some embodiments include robotic elements for, as an example, facilitating robotically controlled access, navigation, imaging, and/or treatment. Assessment of vertebral endplate degeneration or defects (e.g., pre-Modic changes) to facilitate identification of treatment sites and protocols are also provided in several embodiments. Systems or kits of access tools for accessing target treatment locations within vertebral bodies are also provided.

### BACKGROUND

[0003] Back pain is a very common health problem worldwide and is a major cause for work-related disability benefits and compensation. At any given time, low back pain impacts nearly 30% of the US population, leading to 62 million annual visits to hospitals, emergency departments, outpatient clinics, and physician offices. Back pain may arise from strained muscles, ligaments, or tendons in the back and/or structural problems with bones or spinal discs. The back pain may be acute or chronic. Existing treatments for chronic back pain vary widely and include physical therapy and exercise, chiropractic treatments, injections, rest, pharmacological therapy such as opioids, pain relievers or anti-inflammatory medications, and surgical intervention such as vertebral fusion, discectomy (e.g., total disc replacement), or disc repair. Existing treatments can be costly, addictive, temporary, ineffective, and/or can increase the pain or require long recovery times. In

addition, existing treatments do not provide adequate relief for the majority of patients and only a small percentage are surgically eligible.

#### SUMMARY

[0004] Applicant's existing technology (the Intracept® procedure by Relieva®) offers a safe and effective minimally invasive procedure that targets the basivertebral nerve for the relief of chronic vertebrogenic low back pain. As disclosed herein, several embodiments provide bone access tools, additional modalities of relief for patients and/or adjunct technologies.

[0005] In accordance with several embodiments, quantitative efficacy of treatment or efficacy of nerve ablation may be performed by assessing levels of one or more biomarkers (e.g., biomarkers associated with pain, inflammation, or neurotransmission). Such assessment may be particularly useful to assess pain, for example. Pain can be very subjective based on individual patient pain tolerance and perception. Accordingly, it can be difficult to assess or quantify efficacy of pain treatment based on patient feedback. It has also been difficult historically to assess efficacy of nerve ablation in real time. For example, patients may be under anesthetic and unable to provide feedback. In other cases, patients may be awake but unable to accurately assess pain. The use of biomarkers, in some embodiments can facilitate pain assessment or confirmation of efficacy of nerve ablation.

[0006] For example, a level or activity of one or more biomarkers may be measured or otherwise obtained prior to performing a procedure and after performing a procedure. The pre-procedure and post-procedure levels may be compared in order to quantitatively (non-subjectively) assess efficacy. The biomarkers may be associated with pain levels or associated with lesion formation (e.g., efficacy of neurotransmission or neural communication). The assessment of the level of the one or more biomarkers may advantageously be performed in a non-invasive or minimally-invasive (e.g., non-surgical) manner in accordance with several embodiments. Biomarkers may also be used to assess whether a particular subject is likely to be a candidate for nerve ablation treatment for treatment of back pain. For example, the biomarkers may be indicative of pre-Modic changes or symptoms likely to result in Modic changes or endplate damage (e.g., inflammation, edema, bone marrow lesions or fibrosis). The assessment of biomarker levels may indicate which vertebral bodies of a particular subject are candidates for treatment to

prevent (or reduce the likelihood of) back pain from developing or worsening or to treat existing back pain. The pre-procedure biomarker assessment may also be combined with pre-procedure imaging. Mechanisms other than using biomarkers may also be used (in addition or in the alternative) to assess lesion formation (e.g., infrared sensing, heat markers, neurotransmission assessments via stimulation, and/or ultrasound imaging).

[0007] In some embodiments, automated systems for accessing and/or treating tissue (such as nerves) are provided. In accordance with several embodiments, robotically-enabled or robotically-controlled surgical, access, and/or treatment tools may provide a high level of control and precision of movement and increased dexterity and range of motion, thereby providing increased assurance that injury will not occur to tissue not desired to be impacted. Robotically-controlled tools and techniques (e.g., computer-aided tools and techniques that may incorporate artificial intelligence learning and feedback) may also be used to facilitate navigation to, and surgical operation at, desired target treatment regions that may be difficult to access manually, thereby providing enhanced flexibility and possibilities thought not to be possible via manual human surgery. Robotically-controlled tools and techniques (e.g., computer-aided tools and techniques that may incorporate artificial intelligence learning and feedback) may further be used to facilitate capture of images pre-operatively or intra-operatively without exposing the target treatment regions to radiation or without requiring large incisions to be made. Nerve detection devices (e.g., nerve monitoring devices or nerve finders) may also be used to detect nerves along access routes that are desired to be avoided during access. Robotic or automated tools and techniques may reduce numbers of and sizes of incisions (and therefore scars), may reduce blood loss, may reduce pain, and may decrease recovery time.

[0008] Because the target treatment regions within vertebral bodies may be fairly small in size, it may be desirable to control or adjust lesion formation so as to exhibit specific lesion shapes (e.g., football-shape, oval, elliptical, disc-shaped, cigar-shaped, dumbbell-shaped, UFO-shaped, rounded, rectangular, amorphous, etc.). Creating specific lesion shapes may allow clinicians to efficiently ablate a basivertebral nerve trunk within specific vertebral bodies (e.g., cervical, thoracic, lumbar, sacral vertebrae). The specific lesion shapes may provide increased confidence in the efficacy of ablation while limiting the extent of thermal injury within the vertebral body. The lesion shapes may be controlled by applying voltage

differentials between different pairs of electrodes on the same energy delivery probe or on different energy delivery probes for different durations. The lesion formation may be monitored and controlled in real time (e.g., using feedback based on imaging, thermal sensing, and/or artificial intelligence) to further increase confidence and efficiency. Use of two probes and delivering energy between the two probes may result in synergistic lesion formation (e.g., larger lesions than could be formed by individual probes alone).

[0009] Treatment procedures may include modulation of nerves within or surrounding bones. The terms “modulation” or “neuromodulation”, as used herein, shall be given their ordinary meaning and shall also include ablation, permanent denervation, temporary denervation, disruption, blocking, inhibition, electroporation, therapeutic stimulation, diagnostic stimulation, inhibition, necrosis, desensitization, or other effect on tissue. Neuromodulation shall refer to modulation of a nerve (structurally and/or functionally) and/or neurotransmission. Modulation is not necessarily limited to nerves and may include effects on other tissue, such as tumors or other soft tissue.

[0010] In accordance with several embodiments, a method of ablating a basivertebral nerve within a vertebral body of a subject and confirming efficacy of ablation of the basivertebral nerve includes obtaining a first reading (e.g., baseline reading) of a level of a biomarker from the subject. The method further includes performing a denervation procedure on the subject. As one example, the denervation procedure includes denervating the basivertebral nerve within the vertebral body. The method also includes obtaining a second reading (e.g., post-procedure reading) of the level of the biomarker from the subject and determining an effect of the denervation procedure by comparing the second reading to the first reading to assess efficacy of the denervation procedure.

[0011] The biomarkers may include one or more of: an inflammatory cytokine (e.g., interleukins, interferons, tumor necrosis factors, prostaglandins, and chemokines), pain indicators (e.g., substance P, calcitonin gene-related peptides (CGRPs)), an edema factor, and/or other inflammatory factor. The first reading (e.g., baseline reading) and the second reading (e.g., post-procedure reading) may be obtained from cerebrospinal fluid adjacent the vertebral body of the subject, from a blood draw (e.g., at a location within or adjacent the vertebral body of the subject or at a remote location systemically), from a urine sample, or other source. The biomarkers may be circulating inflammatory cells (e.g., cytokines). The

biomarkers may be obtained via one or more immunoassay techniques (e.g., ELISAs, cytokine bead arrays, cytokine microarrays, flow cytometry, immunohistochemical assays, and/or the like).

[0012] The step of denervating the basivertebral nerve within the vertebral body may include applying energy (e.g., radiofrequency energy, ultrasound energy, microwave energy) to a target treatment region within the vertebral body sufficient to denervate (e.g., ablate, electroporate, molecularly dissociate, necrose) the basivertebral nerve using a radiofrequency energy delivery device. The step of denervating may alternatively or additionally include applying an ablative fluid (e.g., steam, chemical, cryoablative fluid) to a target treatment region within the vertebral body. In some implementations, the step of denervating may include delivering a water jet at a pressure sufficient to denervate the nerve (e.g., between 5 and 10 MPa, between 10 and 15 MPa, between 15 and 30 MPa, between 30 and 50 MPa, overlapping ranges thereof, pressure greater than 50 MPa, or any value within the recited ranges).

[0013] In accordance with several embodiments, a method of detecting and treating back pain of a subject includes obtaining images of a vertebral body of the subject, analyzing the images to determine whether the vertebral body exhibits one or more symptoms associated with a pre-Modic change, and ablating a basivertebral nerve within the vertebral body if it is determined that the vertebral body exhibits one or more symptoms associated with a pre-Modic change. The one or more symptoms associated with a pre-Modic change may include edema, inflammation, and/or tissue changes (e.g., tissue lesions, fibrosis, or other changes in tissue type or characteristics) of bone, bone marrow, and/or endplate(s).

[0014] In accordance with several embodiments, a method of treating a vertebral body includes inserting a first access assembly into a first target location of the vertebral body. The first access assembly includes a first cannula and a first stylet configured to be inserted within the first cannula until a distal tip of the first stylet is advanced to or beyond an open distal tip of the first cannula. The method further includes removing the first stylet from the first cannula. The method also includes inserting a second access assembly into a second target location of the vertebral body. The second access assembly including a second cannula and a second stylet configured to be inserted within the second cannula until a distal

tip of the second stylet is advanced to or beyond an open distal tip of the second cannula. The method further includes removing the second stylet. The method also includes inserting a first radiofrequency energy delivery device through the first cannula and inserting a second radiofrequency energy delivery device through the second cannula. The first radiofrequency energy delivery device and the second radiofrequency energy delivery device each include at least two electrodes (e.g., an active electrode and a return electrode configured to act as a bipolar electrode pair). The method further includes positioning the at least two electrodes of the first radiofrequency energy delivery device within the vertebral body and positioning the at least two electrodes of the second radiofrequency energy delivery device within the vertebral body.

[0015] The method also includes applying power to the first and second radiofrequency energy delivery devices sufficient to create a desired lesion shape within the vertebral body sufficient to ablate a basivertebral nerve within the vertebral body (e.g., football-shaped lesion, an elliptical-shaped lesion having a length-to-width ration of at least 2:1, a cross-shaped lesion, an X-shaped lesion, a cigar-shaped lesion). The lesion may have a maximum width of 20 mm and a maximum length of 30 mm. The lesion may have a maximum width of 70-80% of the anteroposterior depth of the vertebral body and a maximum length of 70-85% of the transverse width of the vertebral body. In some implementations, the step of applying power to the first and second radiofrequency energy delivery devices includes independently applying power to the first and second radiofrequency energy delivery devices for a first duration of time (e.g., 1 minute – 2 minutes, 30 seconds – 90 seconds, 2 – 5 minutes, 5 – 10 minutes, 10 – 15 minutes, overlapping ranges thereof, or any value within the recited ranges). In some implementations, the step of applying power to the first and second radiofrequency energy delivery devices further includes applying a voltage differential between at least one of the at least two electrodes of the first radiofrequency energy delivery device and at least one of the at least two electrodes of the second radiofrequency energy delivery device for a second duration of time (e.g., 1 minute – 2 minutes, 30 seconds – 90 seconds, 2 – 5 minutes, 5 – 10 minutes, 10 – 15 minutes, overlapping ranges thereof, or any value within the recited ranges). The first duration of time and the second duration of time may be the same or different.



[0016] In accordance with several embodiments, a method of ablating a basivertebral nerve within a vertebral body includes inserting an access assembly within a vertebral body using a robotically-controlled system. The access assembly includes at least one cannula. The method further includes inserting a radiofrequency energy delivery device through the cannula to a target treatment site within the vertebral body using the robotically-controlled system, and applying power to the target treatment site using the radiofrequency energy delivery device sufficient to ablate the basivertebral nerve.

[0017] In some implementations, the robotically-controlled system includes one or more robotic arms and an operator control console including at least one processor. The system may include one or more imaging devices configured to provide feedback (e.g., based on artificial intelligence processing algorithms) to the robotically-controlled system to control insertion of the access assembly and/or the radiofrequency energy delivery device.

[0018] In accordance with several embodiments, a radiofrequency (“RF”) generator for facilitating nerve ablation includes a display screen (e.g., color active matrix display) and an instrument connection port configured to receive a corresponding connector of a radiofrequency probe. The generator further includes a first indicator light ring (e.g., circular LED indicator light ring) surrounding the instrument connection port that is configured to illuminate when a treatment device is connected to the instrument connection port. The first indicator light ring is configured to continuously illuminate in a solid color (e.g., white, green, blue) when the treatment device is connected to the instrument connection port, to flash at a first pulsing rate (e.g., 1 Hz) to prompt a clinician to connect the treatment device to the instrument connection port, and to flash at a second pulsing rate different than (e.g., greater than 1Hz, such as 2 Hz, 3 Hz or 4 Hz) the first pulsing rate to indicate an error condition. The generator may optionally be configured to output an audible alert or alarm to indicate the error condition. The generator also includes an energy delivery actuation button configured to be pressed by an operator to start and stop delivery of radiofrequency energy and a second indicator light ring (e.g., circular LED light ring) surrounding the actuation button. The second indicator light ring is configured to continuously illuminate in a solid color (e.g., white, blue, green) when the generator is powered on and ready to initiate energy delivery, to flash at a third pulsing rate (e.g., 1 Hz) to prompt the operator to press the actuation button to initiate energy delivery, and to flash at a fourth pulsing rate different than

(e.g., greater than 1 Hz, such as 2 Hz, 3 Hz, 4Hz) the third pulsing rate when energy delivery has been paused or stopped.

[0019] In accordance with several embodiments, a system for facilitating nerve ablation includes an operator control console comprising a computer-based control system including at least one processor that is configured to execute program instructions stored on a non-transitory computer-readable medium to carry out a nerve ablation procedure to ablate a basivertebral nerve within one or more vertebral bodies using automated robotic surgical arms. The one or more robotic surgical arms are configured to move with six or more degrees of freedom and to support or carry access tools (e.g., cannulas, stylets, bone drills, curettes), treatment devices (e.g., radiofrequency probes, microwave ablation catheters, ultrasound probes), and/or diagnostic devices (e.g., cameras, sensors, and/or the like). The system may optionally include one or more imaging devices configured to obtain images of a target treatment site prior to, during, and/or after a treatment procedure.

[0020] In accordance with several embodiments, a method of facilitating ablation of a basivertebral nerve within a vertebral body comprising applying radiofrequency energy to a location within the vertebral body according to the following treatment parameters: a frequency between 400 kHz and 600 kHz (e.g., between 400 kHz and 500 kHz, between 450 kHz and 500 kHz, between 470 kHz and 490 kHz, between 500 kHz and 600 kHz, overlapping ranges thereof, or any value within the recited ranges); a target temperature of between 80 degrees Celsius and 90 degrees Celsius (e.g., 80 degrees Celsius, 85 degrees Celsius, 90 degrees Celsius); a temperature ramp of between 0.5 and 3 degrees Celsius per second (e.g., 0.5 degree Celsius per second, 1 degree Celsius per second, 1.5 degrees Celsius per second, 2 degrees Celsius per second, 2.5 degrees Celsius per second, 3 degrees Celsius per second); and an active energy delivery time of between 10 minutes and 20 minutes (e.g., 10 minutes, 12, minutes, 14 minutes, 15 minutes, 16 minutes, 18 minutes, 20 minutes). In some implementations, a target ablation zone has a major diameter along a long axis of between 20 mm and 30 mm and a minor diameter along a short axis of between 5 mm and 15 mm.

[0021] In accordance with several embodiments, a kit for facilitating nerve ablation includes one or more biological assays configured to determine at least one biological marker (e.g., cytokine, substance P or other indicator of pain, heat shock protein).

The determination includes at least one of a binary detection of a presence of the at least one biological marker, and/or a quantification (e.g., total amount) of the at least one biological marker. The determination may also optionally include an indication of location of any of the at least one biomarker or a location of a highest concentration of the at least one biomarker.

[0022] The kit may optionally include one or more access tools (e.g., stylets, cannulas, curettes, bone drills) configured to access a target nerve to be treated (e.g., basivertebral nerve). The kit may also or alternatively optionally include one or more treatment tools configured to modulate (e.g., ablate, stimulate, denervate, inhibit, necrose, electroporate, molecularly dissociate) the target nerve. The optional treatment tool include one or a combination of the following: a radiofrequency energy delivery device, a microwave energy delivery device, an ultrasound energy delivery device, a cryomodulation device (e.g., cryoablation device), a laser energy delivery device, and/or a drug eluting device (e.g., chemical or fluid ablation device configured to elute a fluid capable of denervating or ablating a nerve, such as alcohol or phenol).

[0023] In accordance with several embodiments, a method of detecting and treating back pain of a subject includes obtaining images of a vertebral body of the subject and analyzing the images to determine whether the vertebral body exhibits one or more symptoms associated with a pre-Modic change. The method also includes modulating (e.g., ablating, denervating, stimulating) an intraosseous nerve (e.g., basivertebral nerve) within the vertebral body if it is determined that the vertebral body exhibits one or more symptoms associated with a pre-Modic change.

[0024] The images may be obtained, for example, using an MRI imaging modality, a CT imaging modality, an X-ray imaging modality, an ultrasound imaging modality, or fluoroscopy. The one or more symptoms associated with a pre-Modic change may comprise characteristics likely to result in Modic changes (e.g., Type 1 Modic changes, Type 2 Modic changes). The one or more symptoms associated with a pre-Modic change may comprise initial indications or precursors of edema or inflammation at a vertebral endplate prior to a formal characterization or diagnosis as a Modic change. The one or more symptoms may include edema, inflammation, and/or tissue change within the vertebral body or along a portion of a vertebral endplate of the vertebral body. Tissue changes may include

tissue lesions or changes in tissue type or characteristics of an endplate of the vertebral body and/or tissue lesions or changes in tissue type or characteristics of bone marrow of the vertebral body. The one or more symptoms may include focal defects, erosive defects, rim defects, and corner defects of a vertebral endplate of the vertebral body.

[0025] The thermal treatment dose applied may include delivery of one or more of radiofrequency energy, ultrasound energy, microwave energy, and laser energy. Ablating the basivertebral nerve within the vertebral body may comprise applying a thermal treatment dose to a location within the vertebral body of at least 240 cumulative equivalent minutes (“CEM”) using a CEM at 43 degrees Celsius model. In some embodiments, the thermal treatment dose is between 200 and 300 CEM (e.g., between 200 and 240 CEM, between 230 CEM and 260 CEM, between 240 CEM and 280 CEM, between 235 CEM and 245 CEM, between 260 CEM and 300 CEM) or greater than a predetermined threshold (e.g., greater than 240 CEM).

[0026] In some embodiments, ablating the basivertebral nerve within the vertebral body comprises advancing at least a distal end portion of a radiofrequency energy delivery probe comprising two electrodes (e.g., a bipolar probe having an active electrode and a return electrode) to a target treatment location within the vertebral body and applying radiofrequency energy to the location using the energy delivery probe to generate a thermal treatment dose sufficient to modulate (e.g., ablate, denervate, stimulate) the intraosseous nerve (e.g., basivertebral nerve). The radiofrequency energy may have a frequency between 400 kHz and 600 kHz (e.g., between 400 kHz and 500 kHz, between 425 kHz and 475 kHz, between 450 kHz and 500 kHz, between 450 kHz and 550 kHz, between 475 kHz and 500 kHz, between 500 kHz and 600 kHz, overlapping ranges thereof, or any value within the recited ranges). In some embodiments, the thermal treatment dose is configured to achieve a target temperature of between 70 degrees Celsius and 95 degrees Celsius (e.g., between 70 degrees Celsius and 85 degrees Celsius, between 80 degrees Celsius and 90 degrees Celsius, between 85 degrees Celsius and 95 degrees Celsius, overlapping ranges thereof, or any value within the recited ranges) at the location. The thermal treatment dose may be delivered with a temperature ramp of between 0.1 and 5 degrees Celsius per second (e.g., between 0.5 and 1.5 degrees Celsius per second, between 1 and 2 degrees Celsius per second, between 1.5 and 3 degrees Celsius per second, between 0.5 and 3 degrees Celsius per second, between 1.5 and

5 degrees Celsius per second, overlapping ranges thereof, or any value within the recited ranges. In some embodiments, the temperature ramp is greater than 5 degrees Celsius per second. The radiofrequency energy may be applied for an active energy delivery time of between 5 minutes and 30 minutes (e.g., between 5 minutes and 15 minutes, between 10 minutes and 20 minutes, between 15 minutes and 30 minutes, overlapping ranges thereof, or any value within the recited ranges). The thermal treatment dose may form a targeted lesion zone at the target treatment location having a maximum cross-sectional dimension of less than 15 mm.

[0027] Ablating the basivertebral nerve may comprise generating a targeted ablation zone formed by a lesion having a “football” or elliptical profile shape. Ablating the basivertebral nerve may comprise generating a targeted ablation zone having a maximum cross-sectional dimension (e.g., diameter, height, width, length) of less than 15 mm. In some embodiments, ablating the basivertebral nerve comprises generating a targeted ablation zone having a maximum cross-sectional dimension (e.g., major diameter) along a long axis of between 20 mm and 30 mm and a maximum cross-sectional dimension (e.g., minor diameter) along a short axis of between 5 mm and 15 mm.

[0028] In some embodiments, the method is performed without use of any cooling fluid. The method may further include modulating (e.g., ablating, denervating, stimulating) an intraosseous nerve (e.g., basivertebral nerve) within a second vertebral body superior to or inferior to the first vertebral body.

[0029] In accordance with several embodiments, a method of detecting and treating back pain of a subject includes identifying a candidate vertebral body for treatment based on a determination that the vertebral body exhibits one or more symptoms or defects associated with vertebral endplate degeneration and ablating a basivertebral nerve within the identified candidate vertebral body by applying a thermal treatment dose to a location within the vertebral body of at least 240 cumulative equivalent minutes (“CEM”) using a CEM at 43 degrees Celsius model. The one or more symptoms associated with vertebral endplate degeneration or defects include pre-Modic change characteristics.

[0030] In some embodiments, the determination is based on images of the candidate vertebral body (e.g., MRI images, CT images, X-ray images, fluoroscopic images, ultrasound images). In some embodiments, the determination is based on obtaining

biomarkers from the subject. The biomarkers may be obtained, for example, from one or more blood serum samples (e.g., blood plasma). The biomarkers may be obtained over an extended period of time (e.g., a period of days, weeks, or months) or at a single instance in time.

[0031] In some embodiments, the location of the applied thermal treatment dose is in a posterior half of the vertebral body. The location may include a geometric center of the vertebral body. The location may be at least 5 mm (e.g., at least 1 cm) from a posterior border (e.g., posterior cortical aspect) of the vertebral body.

[0032] In some embodiments, the method includes advancing at least a distal end portion of a bipolar radiofrequency energy delivery probe having two electrodes to the location. The method may further include forming a passageway through a pedicle and into the vertebral body, then advancing at least the distal end portion of the bipolar radiofrequency energy delivery probe along the passageway to the location, and then applying the thermal treatment dose to the location using the bipolar radiofrequency energy delivery probe.

[0033] In some embodiments, the method further includes applying radiofrequency energy to a second location within a second vertebral body. The second vertebral body may be of a vertebra of a different vertebral level than the first vertebral body. The second vertebral body may be of a vertebra adjacent to the first vertebral body.

[0034] In accordance with several embodiments, an introducer system adapted to facilitate percutaneous access to a target treatment location within bone (e.g., a vertebral body) includes an introducer cannula comprising a proximal handle and a distal elongate hypotube extending from the proximal handle. The system further includes an introducer stylet comprising a proximal handle and a distal elongate shaft extending from the proximal handle. The proximal handle of the introducer includes a central opening in its upper surface that is coupled to a lumen of the distal elongate hypotube to facilitate insertion of the introducer stylet into the central opening and into the distal elongate hypotube of the introducer cannula. The proximal handle of the introducer cannula includes one or more slots configured to receive at least a portion of the proximal handle of the introducer stylet so as to facilitate engagement and alignment between the introducer stylet and the introducer cannula. The proximal handle of the introducer stylet includes an anti-rotation tab

configured to be received within one of the one or more slots so as to prevent rotation of the introducer stylet within the introducer cannula. A distal end of the distal elongate shaft of the introducer stylet includes a distal cutting tip and a scalloped section proximal to the distal cutting tip so as to provide gaps between an outer diameter of the distal end of the distal elongate shaft and the inner diameter of the introducer cannula.

[0035] In some embodiments, the proximal handle of the introducer stylet further includes a press button that, when pressed: (a) disengages the anti-rotation tab and allows for rotation of the introducer stylet within the introducer stylet, and (b) allows for removal of the introducer stylet from the introducer cannula. The proximal handle of the introducer stylet may include a ramp configured to provide a mechanical assist for removal of the introducer stylet from the introducer cannula. The proximal handle of the introducer cannula may comprise a T-shaped, or smokestack shaped, design.

[0036] The introducer system may further include a curved cannula assembly. The curved cannula assembly may include a cannula comprising a proximal handle with a curved insertion slot and a distal polymeric tube. The distal polymeric tube may include a curved distal end portion having a preformed curvature but configured to bend when placed under constraint (e.g., constraint by insertion through a straight introducer cannula). The curved cannula assembly may further include a stylet comprising a proximal handle and a distal elongate shaft. The distal elongate shaft includes a curved distal end portion having a preformed curvature but configured to bend when placed under constraint (e.g., constraint by insertion through a cannula or bone tissue) and a distal channeling tip. A length of the curved distal end portion of the distal elongate shaft proximal to the distal channeling tip (e.g., a springboard or platform portion) may comprise a cross-section circumference profile that is less than a full cross-section circumference profile (e.g., cross-section circumference profile of neighboring or adjacent portions of the distal elongate shaft or of the distal channeling tip), such that there is a larger gap between an outer cross-sectional dimension of the curved distal end portion of the distal elongate shaft and the inner diameter of the curved distal end portion of the cannula along the length of the curved distal end portion of the distal elongate shaft proximal to the distal channeling tip. The less than full cross-section circumference profile may comprise a "D" shape. The overall cross-section circumference profile may thus be asymmetric (e.g., not uniform or constant along its entire length).

[0037] The proximal handle of the stylet may include a bail mechanism comprises a bail actuator that is adapted to cause axial movement (e.g., proximal movement upon actuation) of the distal channeling tip of the distal elongate shaft of the stylet with respect to the cannula so as to facilitate insertion of the curved cannula assembly through the introducer cannula and withdrawal of the stylet of the curved cannula assembly from the cannula of the curved cannula assembly after formation of a curved path within the bone.

[0038] The introducer system may further include an introducer drill adapted to be introduced into and through the introducer cannula to form a further path within the bone after removal of the introducer stylet from the introducer cannula. The introducer drill may include a fluted distal portion and a distal drill tip, wherein drill flutes of the fluted distal portion taper away (e.g., flutes go from higher volume to lower volume) from the distal drill tip so as to facilitate improved bone chip packing within an open volume defined by the drill flutes as bone chips are generated by operation of the introducer drill. The aforementioned system components may be provided as a kit with instructions for use.

[0039] In accordance with several embodiments, a system configured to provide curved access within bone includes a cannula comprising a proximal handle with a curved insertion slot and a distal polymeric tube, with the distal polymeric tube including a curved distal end portion having a preformed curvature but configured to bend when placed under constraint. The system further includes a stylet comprising a proximal handle and a distal elongate shaft, wherein the distal elongate shaft includes a curved distal end portion having a preformed curvature but configured to bend when placed under constraint and a distal channeling tip. A length of the curved distal end portion of the distal elongate shaft proximal to the distal channeling tip comprises a cross-section circumference profile that is less than a full cross-section circumference profile such that there is a larger gap between an outer cross-sectional dimension of the curved distal end portion of the distal elongate shaft and the inner diameter of the curved distal end portion of the cannula along the length of the curved distal end portion of the distal elongate shaft proximal to the distal channeling tip. In some embodiments, the cross-section circumference profile comprises a "D" shape. An upper surface of the length of the curved distal end portion may be generally flat. The proximal handle of the stylet may include a bail configured to be actuated so as to cause proximal axial retraction of the stylet with respect to the cannula when the proximal handle of the stylet is



engaged with the proximal handle of the cannula. In some embodiments, the curved distal end portion of the distal elongate shaft is constructed such that the preformed curvature of the curved distal end portion does not deviate by more than 20 degrees upon insertion within the bone. A maximum vertical cross-sectional dimension of the length of the curved distal end portion may be between 40% and 80% (e.g., between 40% and 60%, between 45% and 70%, between 50% and 65%, between 60% and 80%, overlapping ranges thereof, or any value within the recited ranges) of a maximum cross sectional dimension of proximal and distal regions of the curved distal end portion bordering the length of the curved distal end portion. The system components may be provided as a kit with instructions for use.

[0040] In accordance with several embodiments, a method of accessing a target treatment location within a vertebral body identified as having hard bone includes advancing an introducer assembly through skin adjacent the vertebral body and into a pedicle connected to the vertebral body, the introducer assembly including an introducer stylet inserted within an introducer cannula with a distal cutting tip of the introducer stylet extending out of the introducer cannula. The method further includes removing the introducer stylet from the introducer cannula while leaving the introducer cannula in place. The method also includes inserting an introducer drill through and beyond the introducer cannula and through the pedicle and into cancellous bone of the vertebral body. Inserting the introducer drill includes rotating the introducer drill. The introducer drill includes a fluted distal portion and a distal drill tip. The drill flutes of the fluted distal portion taper away from the distal drill tip so as to facilitate improved bone chip packing within an open volume defined by the drill flutes as bone chips are generated by operation of the introducer drill.

[0041] In accordance with several embodiments, inserting the introducer drill may involve not malleting on the introducer drill. In some embodiments, inserting the introducer drill does include malleting on a proximal handle of the introducer drill. The method may further include removing the introducer drill from the introducer cannula. The method may also include inserting a curved cannula assembly into a curved slot of a proximal handle of the introducer cannula. The curved cannula assembly may include a second cannula including a proximal handle with a curved insertion slot and a distal polymeric tube, wherein the distal polymeric tube includes a curved distal end portion having a preformed curvature but configured to bend when placed under constraint. The curved

cannula assembly may also include a second stylet including a proximal handle and a distal elongate shaft. The distal elongate shaft of the second stylet includes a curved distal end portion having a preformed curvature but configured to bend when placed under constraint and a distal channeling tip. A length of the curved distal end portion of the distal elongate shaft proximal to the distal channeling tip may comprise a cross-section circumference profile that is less than a full cross-section circumference profile such that there is a larger gap between an outer cross-sectional dimension of the curved distal end portion of the distal elongate shaft and the inner diameter of the curved distal end portion of the second cannula along the length of the curved distal end portion of the distal elongate shaft proximal to the distal channeling tip.

[0042] In some embodiments, the method further includes removing the second stylet from the second cannula. The method may also include inserting a third stylet into a slot of the proximal handle of the second cannula and beyond an open distal tip of the second cannula, wherein the third stylet is configured to form a straight path (e.g., beyond a curved path formed by the curved cannula assembly) starting from the open distal tip of the second cannula toward the target treatment location, and removing the third stylet from the second cannula after formation of the straight path. The method may include inserting a treatment device into the slot of the proximal handle of the second cannula and beyond the open distal tip of the second cannula to the target treatment location and performing therapy at the target treatment location using the treatment device. The therapy may include ablating at least 75% of the branches of a basivertebral nerve within the bone (e.g., vertebral body).

[0043] Several embodiments of the invention have one or more of the following advantages: (i) increased treatment accuracy; (ii) increased efficacy and enhanced safety; (iii) increased efficiency; (iv) increased precision; (v) synergistic results; (vi) “one-and-done” procedure that does not require further surgical intervention; (vii) treatment of chronic low back pain; (viii) prevention of pain due to early detection of factors likely to cause pain in the future; (ix) reduction of unwanted stoppages or interruptions in treatment procedure (x) ease of use (e.g., due to reduced friction or force).

[0044] For purposes of summarizing the disclosure, certain aspects, advantages, and novel features of embodiments of the disclosure have been described herein. It is to be understood that not necessarily all such advantages may be achieved in accordance with any

particular embodiment of the disclosure provided herein. Thus, the embodiments disclosed herein may be embodied or carried out in a manner that achieves or optimizes one advantage or group of advantages as taught or suggested herein without necessarily achieving other advantages as may be taught or suggested herein.

[0045] The methods summarized above and set forth in further detail below describe certain actions taken by a practitioner; however, it should be understood that they can also include the instruction of those actions by another party. Thus, actions such as “For example, actions such as “applying thermal energy” include “instructing the applying of thermal energy.” Further aspects of embodiments of the disclosure will be discussed in the following portions of the specification. With respect to the drawings, elements from one figure may be combined with elements from the other figures.

#### BRIEF DESCRIPTION OF THE DRAWINGS

[0046] Several embodiments of the disclosure will be more fully understood by reference to the following drawings which are for illustrative purposes only:

[0047] FIGURE 1 illustrates various vertebral levels and vertebrae that may be treated by the systems and methods described herein.

[0048] FIGURE 2 illustrates pelvic bones of a human to illustrate potential methods of accessing certain vertebral bodies.

[0049] FIGURE 3 illustrates an example kit or system of access tools configured to access a vertebral body.

[0050] FIGURES 3A-3C include various views of an introducer cannula of the kit or system of FIGURE 3.

[0051] FIGURE 3D is a side view of an introducer stylet of the kit or system of FIGURE 3 and FIGURE 3E is a side view of a distal cutting tip of an introducer stylet.

[0052] FIGURES 3F-3H illustrate a proximal portion of an introducer assembly of the kit or system of FIGURE 3.

[0053] FIGURE 3I is a side view and FIGURE 3J is a top view of a curved cannula of the kit or system of FIGURE 3.

[0054] FIGURE 3K is a side view of a J-stylet of the kit or system of FIGURE 3 and FIGURES 3L and 3M show a side view and a perspective view of a curved distal end portion of the J-stylet of FIGURE 3K.

[0055] FIGURES 3N and 3O illustrate insertion of the J-stylet of FIGURES 3K-3M into the curved cannula of FIGURES 3I and 3J.

[0056] FIGURE 3P illustrates insertion of the curved cannula assembly of the kit or system of FIGURE 3 into the introducer cannula of FIGURES 3A-3C. FIGURE 3Q is a side cross-section view of a proximal portion of the introducer cannula and the curved distal end portions of the curved cannula assembly.

[0057] FIGURES 3R and 3S illustrate operation of a gear wheel of the curved cannula of FIGURES 3I and 3J in connection with insertion of the curved cannula assembly into the introducer cannula. FIGURES 3T and 3U illustrate operation of a bail of the J-stylet of FIGURES 3K-3M to facilitate insertion and retraction of the J-stylet from the curved cannula.

[0058] FIGURE 3V is a side view of a straight stylet of the kit or system of FIGURE 3 and FIGURE 3W is side cross-section view of a distal end portion of the straight stylet.

[0059] FIGURES 3X-3Z illustrate an optional introducer drill of the kit or system of FIGURE 3. FIGURE 3Z illustrates the introducer drill inserted fully within the introducer cannula.

[0060] FIGURES 3AA-3HH illustrate various steps of a method of accessing and treating tissue within a vertebral body using one or more of the access tools of the kit or system of FIGURE 3.

[0061] FIGURE 4 illustrates an example radiofrequency generator.

[0062] FIGURE 5A-5D illustrate example lesion shapes configured to be formed to ablate intraosseous nerves within bone (e.g., vertebral body).

[0063] FIGURE 6 illustrates an example of a system including two probes and two introducer assemblies configured to facilitate formation of a desired lesion.

[0064] FIGURE 7 illustrates a schematic block diagram of a robotically-enabled system.

#### DETAILED DESCRIPTION

[0065] Several implementations described herein are directed to systems and methods for modulating nerves within or adjacent (e.g., surrounding) bone. In some implementations, an intraosseous nerve (e.g., basivertebral nerve) within a bone (e.g.,

vertebral body) of the spine is modulated for treatment, or prevention of, chronic back pain. The vertebral body may be located in any level of the vertebral column (e.g., cervical, thoracic, lumbar and/or sacral). **FIGURE 1** schematically illustrates a vertebral column and the various vertebral segments or levels. Multiple vertebral bodies may be treated in a single visit or procedure (simultaneously or sequentially). The multiple vertebral bodies may be located in a single spine segment (e.g., two adjacent vertebral bodies in the sacral spine segment (e.g., S1 and S2) or lumbar spine segment (e.g., L3, L4 and/or L5) or thoracic spine segment or cervical spine segment) or in different spine segments (e.g., an L5 vertebra in the lumbar spine segment and an S1 vertebra in the sacral spine segment). Intraosseous nerves within bones other than vertebral bodies may also be modulated. For example, nerves within a humerus, radius, femur, tibia, calcaneus, tarsal bones, hips, knees, and/or phalanges may be modulated.

[0066] In some implementations, the one or more nerves being modulated are extraosseous nerves located outside the vertebral body or other bone (e.g., at locations before the nerves enter into, or after they exit from, a foramen of the bone). Other tissue in addition to, or alternative to, nerves may also be treated or otherwise affected (e.g., tumors or other cancerous tissue or fractured bones). Portions of nerves within or on one or more vertebral endplates or intervertebral discs between adjacent vertebral bodies may be modulated.

[0067] The modulation of nerves or other tissue may be performed to treat one or more indications, including but not limited to chronic low back pain, upper back pain, acute back pain, joint pain, tumors in the bone, and/or bone fractures. The modulation of nerves may also be performed in conjunction with bone fusion or arthrodesis procedures so as to provide synergistic effects or complete all-in-one, “one-and-done” treatment that will not require further surgical or minimally invasive interventions.

[0068] In some implementations, fractures within the bone may be treated in addition to denervation treatment and/or ablation of tumors by applying heat or energy and/or delivering agents or bone filler material to the bone. For example, bone morphogenetic proteins and/or bone cement may be delivered in conjunction with vertebroplasty or other procedures to treat fractures or promote bone growth or bone healing. In some implementations, energy is applied and then agents and/or bone filler material is delivered in a combined procedure. In some aspects, vertebral compression fractures (which may be

caused by osteoporosis or cancer) are treated in conjunction with energy delivery to modulate nerves and/or cancerous tissue to treat back pain.

[0069] In accordance with several implementations, the systems and methods of treating back pain or facilitating neuromodulation of intraosseous nerves described herein can be performed without surgical resection, without general anesthesia, without cooling (e.g., without cooling fluid), and/or with virtually no blood loss. In some embodiments, the systems and methods of treating back pain or facilitating neuromodulation of intraosseous nerves described herein facilitate easy retreatment if necessary. In accordance with several implementations, successful treatment can be performed in challenging or difficult-to-access locations and access can be varied depending on bone structure or differing bone anatomy. One or more of these advantages also apply to treatment of tissue outside of the spine (e.g., other orthopedic applications or other tissue).

## **ACCESS TO THE VERTEBRAL BODY**

### **Methods of Access**

[0070] Various methods of access may be used to access a vertebral body or other bone. In some implementations, the vertebral body is accessed transpedicularly (through one or both pedicles). In other implementations, the vertebral body is accessed extrapedicularly (e.g., without traversing through a pedicle). In some implementations, the vertebral body is accessed using an extreme lateral approach or a transforaminal approach, such as used in XLIF and TLIF interbody fusion procedures. In some implementations, an anterior approach is used to access the vertebral body.

[0071] Certain vertebrae in the sacral or lumbar levels (e.g., S1 vertebra, L5 vertebra) may also be accessed generally posterolaterally using a trans-iliac approach (e.g., an approach through an ilium bone). With reference to **FIGURE 2**, an access hole may be formed through the ilium at a location designed to facilitate access to the vertebral body or bodies in the sacral or lumbar region. For example, access tools (e.g., an introducer assembly including a cannula/stylet combination) may be delivered through an ilium and/or sacroiliac joint or sacral ala into an S1 vertebra under image guidance (e.g., CT image guidance and/or fluoroscopy) and/or using stereotactic or robotic-assisted surgical and/or navigation systems, such as the robotic system described in connection with **FIGURE 7**. A treatment device

could then be inserted through an introducer and/or other access cannula of the access tools to a target treatment location within a sacral or lumbar vertebra. A trans-iliac approach may advantageously increase the ability of the clinician to access the target treatment location in a particular portion or region of the vertebral body (e.g., posterior portion or region) that is not capable of being adequately accessed using a transpedicular approach. In some implementations, the vertebral body may be accessed directly through the cerebrospinal fluid and through the dura into a posterior region of the vertebral body.

[0072] In some implementations, the vertebral body may be accessed transforaminally through a basivertebral foramen. Transforaminal access via the spinal canal may involve insertion of a “nerve finder” or nerve locator device and/or imaging/diagnostic tool to avoid damaging spinal cord nerves upon entry by the access tools or treatment devices. The nerve locator device may comprise a hand-held stimulation system such as the Checkpoint Stimulator and Locator provided by Checkpoint Surgical® or the EZstim® peripheral nerve stimulator/nerve locators provided by Avanos Medical, Inc. The nerve finder or nerve locator device could advantageously identify sensitive nerves that should be avoided by the access tools so as not to risk paralysis or spinal cord injury upon accessing the target treatment site. The nerve locator device may be configured to apply stimulation signals between two points or locations and then assess response to determine presence of nerves in the area between the two points or locations. The nerve locator device may include a bipolar pair of stimulation electrodes or monopolar electrodes. In some implementations, the nerve locator features may be implemented on the access tools or treatment devices themselves as opposed to a separate stand-alone device.

#### **Access Tools and Treatment Devices**

[0073] Access tools may include an introducer assembly including an outer cannula and a sharpened stylet, an inner cannula configured to be introduced through the outer cannula, and/or one or more additional stylets, curettes, or drills to facilitate access to an intraosseous location within a vertebral body or other bone. The access tools (e.g., outer cannula, inner cannula, stylets, curettes, drills) may have pre-curved distal end portions or may be actively steerable or curveable. Any of the access tools may have beveled or otherwise sharp tips or they may have blunt or rounded, atraumatic distal tips. Curved drills

may be used to facilitate formation of curved access paths within bone. Any of the access tools may be advanced over a guidewire in some implementations.

[0074] The access tools may be formed of a variety of flexible materials (e.g., ethylene vinyl acetate, polyethylene, polyethylene-based polyolefin elastomers, polyetheretherketone, polypropylene, polypropylene-based elastomers, styrene butadiene copolymers, thermoplastic polyester elastomers, thermoplastic polyurethane elastomers, thermoplastic vulcanizate polymers, metallic alloy materials such as nitinol, and/or the like). Combinations of two or more of these materials may also be used. The access tools may include chevron designs or patterns or slits along the distal end portions to increase flexibility or bendability. Any of the access tools may be manually or automatically rotated (e.g., using a robotic control system such as described in connection with FIGURE 7) to facilitate a desired trajectory.

[0075] In some implementations, an outer cannula assembly (e.g., introducer assembly) includes a straight outer cannula and a straight stylet configured to be received within the outer cannula. The outer cannula assembly may be inserted first to penetrate an outer cortical shell of a bone and provide a conduit for further access tools to the inner cancellous bone. An inner cannula assembly may include a cannula having a pre-curved or steerable distal end portion and a stylet having a corresponding pre-curved or steerable distal end portion. Multiple stylets having distal end portions with different curvatures may be provided in a kit and selected from by a clinician. The inner cannula assembly may alternatively be configured to remain straight and non-curved.

[0076] With reference to FIGURE 3, in one implementation, a kit or system of access tools includes an introducer assembly 110 comprised of an introducer cannula 112 and an introducer stylet 114, a curved cannula assembly 210 comprised of a curved cannula 212 and a J-stylet 214, and a straight stylet 314. The introducer stylet 114 may be bevel tipped, trocar tipped, and/or diamond tipped. The introducer stylet 114 is configured to be received in a lumen of the introducer cannula 112 in a manner such that a distal tip of the introducer stylet 114 protrudes from an open distal tip of the introducer cannula 112, thereby forming the introducer assembly 110 in combination. The J-stylet 214 is configured to be received in a lumen of the curved cannula 212 in a manner such that a distal tip of the J-stylet 214 protrudes from an open distal tip of the curved cannula 212, thereby forming the curved



cannula assembly 210 in combination. The curved cannula 212 and the J-stylet 214 may each comprise a straight proximal main body portion and a curved distal end portion. The curves of the curved distal end portions of the curved cannula 212 and the J-stylet 214 may correspond to each other. The straight stylet 314 is a flexible channeling stylet configured to be delivered through the curved cannula 212 and then to form and maintain a straight or generally straight path upon exiting the open distal tip of the curved cannula 212.

[0077] The access tools may be provided as a kit that may optionally additionally include one or more additional introducer cannulas, one or more additional introducer stylets (e.g., with different tips, such as one with a bevel tip and one with a diamond or trocar tip), one or two or more than two additional curved cannulas (e.g., having a curved distal end portion of a different curvature than a first curved cannula), an additional J-stylet (e.g., having a different curvature or different design configured to access hard bone), an introducer drill 440, and/or an additional straight stylet (e.g., having a different length than the first straight stylet).

[0078] In some embodiments, the access tools (e.g., kit) may be specifically designed and adapted to facilitate access to hard, non-osteoporotic bone (e.g., bone surrounding or within a vertebral body, such as a cervical vertebra, a thoracic vertebra, a lumbar vertebra, or a sacral vertebra). Hard bone may be determined based on bone mass density testing, compressive strength determinations, compressive modulus determinations, imaging modalities, or based on tactile feel by the operator as access instruments are being advanced. In some implementations, hard bone may be determined as bone having a bone mineral density score within a standard deviation of a normal healthy young adult (e.g., a T score greater than or equal to -1). In some implementations, hard bone may be identified as bone having a compressive strength of greater than 4 MPa and/or a compressive modulus of greater than 80 MPa for cancellous bone and greater than 5.5 MPa and/or a compressive modulus of greater than 170 MPa for cortical bone. Some kits may include at least two of every access instrument. Some kits may include optional add-on components or accessory kit modules for accessing hard bone (e.g., the introducer drill 440 and J-stylet 214 specially configured to access hard bone). Some kits may include optional additional access tool components or accessory kit modules adapted to access one or more additional vertebrae in

the same spinal segment or in different spinal segments. The kit may also include one or more (e.g., at least two) treatment devices (such as radiofrequency energy delivery probes).

[0079] FIGURES 3A-3C illustrate various views of an embodiment of the introducer cannula 112. The introducer cannula 112 includes a proximal handle 116 and a distal hypotube 118 extending from the proximal handle 116. The illustrated proximal handle 116 comprises a “smokestack” or “T-Handle” design configuration adapted to provide sufficient finger clearance and gripping (e.g., two fingers on each side of a lower flange 113 of the proximal handle 116 and along the lower surface of a crossbar portion 115) to facilitate removal. However, alternative design configurations for the proximal handle other than a “smokestack” or “T-handle” design may be incorporated.

[0080] The proximal handle 116 includes an upper central opening 120 configured to facilitate straight axial insertion of an introducer stylet 114 or other straight access tool. The upper central opening 120 may be positioned so as to correspond with (e.g., be coaxial with) a central lumen extending through the hypotube 118 of the introducer cannula 112 so as to facilitate insertion of straight instruments (e.g., introducer stylet 114 or steerable cannulas or steerable stylets) therethrough. The proximal handle 116 may also include coupling features 121 (e.g., recesses, notches, grooves, tabs) to facilitate coupling or mating of a proximal handle 216 of the introducer stylet 114 with the proximal handle 116 of the introducer cannula 112. The coupling features 121 may be adapted to prevent rotation of the introducer stylet 114 and/or to provide assurance that a distal tip 125 of the introducer stylet 114 extends beyond an open distal tip 122 of the hypotube 118 of the introducer cannula 112 so as to enable penetration of the distal tip 125 of the introducer stylet 114 through bone. The upper surface of the proximal handle 116 of the introducer cannula 112 also includes a curved lateral slot 117 and curved ramp 141 to facilitate insertion of the curved cannula assembly 210 into the proximal handle 116 and then into and along the central lumen of the hypotube 118.

[0081] The central lumen of the hypotube 118 extends from the proximal handle 116 to the open distal tip 122 of the hypotube 118. The hypotube 118 may be flared or tapered such that the diameter of the hypotube 118 is not constant along its entire length. For example, the diameter may decrease abruptly at a certain distance (e.g., 1 cm – 3 cm) from a lower edge of the lower flange 113 of the proximal handle 116 and then continue with a

constant diameter distally of an abrupt flare 119. In another embodiment, the diameter may decrease gradually (e.g., taper uniformly) along the length of the hypotube 118 from the start of the flare 119 to the open distal tip 122 of the hypotube 118. The central lumen of the hypotube 118 may be coated with a medical grade silicone lubricant to improve tool insertion and removal. The outer diameter of the hypotube 118 may range from 4.2 mm to 4.5 mm.

[0082] The proximal handle 116 of the introducer cannula 112 may also include an overdrive indication mechanism configured to indicate when the curved cannula assembly 210 has been fully deployed from the introducer cannula such that further advancement of the curved cannula would place the curved cannula assembly 210 at risk of being overdriven from the introducer cannula 112, which could result in damage to the curved cannula assembly 210. The overdrive indication mechanism may comprise two slots 123 in the upper surface of the crossbar portion 115 of the proximal handle 116 that display a bi-stable (i.e., on-off states) indicator of a first color when overdrive is likely not a risk and a second color when overdrive is likely a risk (e.g., curved cannula assembly 210 has been fully deployed). In accordance with several embodiments, there are advantageously two distinct states of operation and there is no transition zone between the two states. The overdrive indication mechanism may be configured to be activated only when a gear wheel 221 of the curved cannula assembly 210 is bottomed out (e.g., fully engaged with the proximal handle 116 of the introducer cannula 112). As shown in FIGURE 3C, a lower (bottom) side surface of the proximal handle 116 of the introducer cannula may include a cutout 124 adapted to receive a portion of a flexible shaft of a treatment device (e.g., radiofrequency probe comprised of nitinol or other flexible or shape memory material) and hold it in place and out of the way during a treatment procedure, thereby reducing stack height (e.g., by approximately 3 inches (or approximately 75 mm) or more).

[0083] FIGURES 3D-3H illustrate various views and portions of embodiments of introducer stylets 114. FIGURE 3D illustrates a side view of an introducer stylet 114. The introducer stylet 114 includes a proximal handle 126 and a distal elongate member or shaft 128. The proximal handle 126 comprises an upper surface that is adapted for malleting by a mallet and a lower surface that is adapted to facilitate removal of the introducer stylet 114 by an operator. The length of the distal elongate member 128 may range from 8 mm to 14 mm (e.g., 8 mm, 8.5 mm, 9 mm, 9.5 mm, 10 mm, 10.5 mm, 11 mm, 11.5 mm, 12 mm,

12.5 mm, 13 mm, 13.5 mm, 14 mm). The distal end portion 132 of the introducer stylet 114 may comprise a scalloped section 133 (as shown more closely in FIGURE 3E) to provide a release mechanism for bone compaction. The scalloped section 133 may be designed to have a side profile shaped generally like an hourglass. The scalloped section 133 may gradually taper from a full diameter proximal portion to a narrow-most middle portion and then gradually taper back to a full diameter distal portion. The taper may be symmetric or asymmetric. The scalloped section 133 may comprise one scallop (or scooped-out region) or multiple scallops (or scooped-out regions) along the length of the distal end portion 132. A distal tip 125 of the distal end portion 132 may comprise a full diameter so as to be adapted to break apart bone (e.g., pedicle bone, cortical bone of a vertebral body). As the bone is broken up by the distal tip 125 of the distal end portion 132, bone shards or chips can pack into a gap formed between the distal end portion 132 of the introducer stylet 114 and the inner surface of the distal end portion of the introducer cannula 112, thereby making it more difficult for the introducer stylet 114 to be removed from the introducer cannula 112. In accordance with several embodiments, the scalloped section 133 of the introducer stylet 114 advantageously provides the bone shards and fragments a place to fall into during removal of the introducer stylet 114 so as to facilitate easier removal of the introducer stylet 114.

[0084] FIGURES 3F-3H illustrate the introducer assembly 110 after the introducer stylet 114 has been inserted within the introducer cannula 112. As indicated above, the proximal handle 116 of the introducer cannula 112 may include mating or engagement features (e.g., coupling features 121) that facilitate automatic (e.g., snap-fit) engagement of the introducer stylet 114 with the proximal handle 116 of the introducer cannula 112.

[0085] The proximal handle 126 of the introducer stylet 114 includes an alignment indicator 129, an anti-rotation tab 131, and a press button 134. As shown best in FIGURE 3G, the alignment indicator 129 is configured to align with a corresponding alignment indicator 130 on the upper surface of the crossbar portion 115 of the proximal handle 116 of the introducer cannula 112 in order to ensure proper insertion and alignment of the introducer stylet 114 with respect to the introducer cannula 112. The anti-rotation tab 131 is configured to be positioned within the slot 117 of the proximal handle 116 of the

introducer cannula 112 and to prevent rotation of the introducer stylet 114 with respect to the introducer cannula 112 during malleting and orienting.

[0086] The press button 134 is integrally coupled to the anti-rotation tab 131 such that pressing of the press button 134 extends the anti-rotation tab 131 out of the constraint of the slot 117, thereby allowing the introducer stylet 114 to rotate with respect to the introducer cannula 112 (as shown in **FIGURE 3H**). Pressing the press button 134 also releases engagement of the introducer stylet 114 with the introducer cannula 112 to enable removal of the introducer stylet 114 from the introducer cannula 112. The proximal handle 126 of the introducer stylet 114 may include internal ramps (not shown) configured to provide a mechanical advantage to assist in removal of the introducer stylet 114 from the introducer cannula 112 (especially if bone shards have packed into gaps between the introducer stylet 114 and introducer cannula 112 making removal more difficult) as the proximal handle 126 is rotated (e.g., 120-degree rotation counter-clockwise). The combination of the scalloped distal end portion design and the internal ramps in the proximal handle 126 may provide increased reduction of removal forces by 50% – 70% compared to a full diameter (e.g., no scalloped section) distal end portion design with no ramps in the proximal handle 126.

[0087] **FIGURES 3I and 3J** illustrate a side view and a top view of an embodiment of the curved cannula 212. The curved cannula 212 includes a proximal handle 216, a threaded proximal shaft portion 220, a gear wheel 221, a rigid support portion 223, and a distal polymeric shaft portion 224. The proximal handle 216 includes a curved slot 217 and a curved ramp 231 configured to facilitate insertion of the J-stylet 214 into and along a central lumen of the curved cannula 212 extending from the proximal handle 216 to an open distal tip 222 of the distal polymeric shaft portion 224. The central lumen of the curved cannula 212 may be coated with a medical grade silicone lubricant to improve tool insertion and removal.

[0088] In the illustrated example, the gear wheel 221 comprises threads configured to interface with corresponding threads of the threaded proximal shaft portion 220 such that rotation of the gear wheel 221 causes controlled proximal and distal translation of the gear wheel 221 along the threaded proximal shaft portion 220. The threaded proximal shaft portion 220 is sized such that when the gear wheel 221 is in its distal-most position, the distal tip 222 of the curved cannula 212 does not extend out of the open distal tip 122 of the

introducer cannula 112 when the curved cannula assembly 210 is fully inserted therein. The gear wheel 221 may spin freely about the threaded proximal shaft portion 220. The threads may comprise triple threads and the gear wheel 221 may be configured to traverse the entire length of the threaded proximal shaft portion 220 with four complete rotations of the gear wheel 221.

[0089] The rigid support portion 223 may comprise a biocompatible metal or other rigid material, such as stainless steel, titanium, platinum and/or the like, so as to provide additional support to the curved cannula 212 during insertion of the J-stylet 214. The distal polymeric shaft portion 224 may be comprised of a thermoplastic, shape-memory polymer material (such as polyether ether ketone (PEEK), polyurethane, polyethylene terephthalate (PET), and/or the like) and the distal end portion 225 is pre-curved (e.g., shape-set) to have a predetermined curve in a “resting” unconstrained configuration.

[0090] FIGURES 3K-3P illustrate an embodiment of the J-stylet 214. FIGURE 3K illustrates a side view of the J-stylet 214 in a “resting” normal, unconstrained configuration or state and FIGURES 3L and 3M are close-up views (side view and perspective view, respectively) of a curved distal end portion 227 of the J-stylet 214. The J-stylet 214 comprises a proximal handle 226 and a distal elongate shaft 218. The proximal handle 226 comprises an upper surface that is adapted for malleting by a mallet and a lower surface that is adapted to facilitate removal of the J-stylet 214 by two or more (e.g., two, three, or four) fingers of an operator. The upper surface of the proximal handle 216 includes an alignment indicator 219 (shown, for example, in FIGURE 3P) configured to be aligned with the corresponding alignment indicator 130 of the introducer cannula 112 to facilitate insertion, removal, and deployment of the J-stylet 214 (and curved cannula assembly 210).

[0091] The distal elongate shaft 218 includes a curved distal end portion 227 having an asymmetric curve profile along its length (e.g., the curved distal end portion does not have a constant full diameter along its length). A distal channeling tip 228 is sized and shaped to facilitate channeling through cancellous bone along a curved path or trajectory. The curved distal end portion 227 comprises a springboard or platform section 229 having a “D-shaped” cross-sectional profile, as shown, for example, by the cross-section profile circle in FIGURE 3M. The springboard or platform section 229 may be formed by mechanical grinding of a tubular wire until the desired D-shaped cross section profile is achieved in

which a top (e.g., upper) surface of the springboard or platform section 229 is generally smooth and flat. The thickness (e.g., vertical cross-sectional dimension) of the springboard or platform section 229, the predefined set angulation or radius of curvature, and the starting and ending points of the springboard or platform section 229 along the length of the curved distal end portion 227 may be varied to provide J-stylets having different rigidity and bending characteristics for different levels of vertebrae or different densities of bone.

[0092] In accordance with several embodiments, a thickness (e.g., a maximum vertical cross-sectional dimension from an upper surface of the springboard or platform section 229 to a lower-most point on a lower surface of the curved distal end portion) is between 40% and 85% (e.g., between 40% and 60%, between 50% and 70%, between 50% and 75%, between 60% and 70%, between 65% and 80%, between 70% and 85%, overlapping ranges thereof, or any value within the recited ranges) of the thickness (e.g., diameter) of the adjacent regions of the curved distal end portion (e.g., the regions just proximal and just distal of the length of the springboard or platform section 229). Instead of percentages, the difference in thickness dimensions could be represented as ratios (e.g., between 2:5 and 4:5, between 2:5 and 3:5, between 1:2 and 3:4, between 3:5 and 4:5, between 3:5 and 6:7). The ending point of the springboard or platform section 229 may be between 4.5 and 9 mm from a distal terminus of the distal elongate shaft 218. The starting point of the springboard or platform section 229 may be between 230 mm and 245 mm from a proximal terminus of the distal elongate shaft 218.

[0093] According to several embodiments, the asymmetric curve profile (e.g., profile with D-shaped cross-section) advantageously provides improved cephalad-caudal steering because the curved distal end portion 227 primarily bends inward and not laterally. In addition, the design and material of the curved distal end portion 227 of the J-stylet 214 may enable the angle of curvature of the curved distal end portion 227 to advantageously remain relatively consistent and reproducible across a variety of bone densities, or regardless of bone environment. For example, in one embodiment, the design and material of the curved distal end portion 227 of the J-stylet 214 facilitates consistent and reproducible access to a posterior location (e.g., in posterior half of the vertebral body or to a location approximately 30%-50% of the distance between the posterior-most aspect and the anterior-most aspect of the vertebral body along a sagittal axis or to a geometric center or midpoint

within the vertebral body for vertebral bodies having varying bone densities or other desired target location in the vertebral body or other bone). In accordance with several embodiments, the curvature is designed to deviate by less than 25 degrees (e.g., less than 20 degrees, less than 15 degrees, less than 10 degrees) or less than 30% from the predefined set curvature of the curved distal end portion 227 in an unconstrained configuration (even in hard bone).

[0094] The J-stylet 214 may be designed and adapted to exert a lateral force of between 6 pounds and 8 pounds. The angle of curvature of the curved distal end portion 227 (with respect to the central longitudinal axis of the straight proximal portion of the distal elongate shaft 218) of the J-stylet 214 in the normal unconstrained state or configuration may be designed to be between 65 degrees and 80 degrees (e.g., 65 degrees, 70 degrees, 75 degrees, 80 degrees, or any other value within the recited range). The radius of curvature of the curved distal end portion 227 may range from 11.5 mm to 15 mm (e.g., from 11.5 mm to 12 mm, from 12 mm to 12.5 mm, from 12 mm to 13 mm, from 12.5 mm to 14 mm, from 13 mm to 15 mm, overlapping ranges thereof, or any value within the recited ranges). The J-stylet 214 may be comprised of nitinol or other metallic alloy material.

[0095] FIGURES 3N and 3O are a perspective view and a side cross-section view, respectively, illustrating insertion of the curved distal end portion 227 of the J-stylet 214 into the slot 217 of the proximal handle 216 of the curved cannula 212. As shown in FIG. 3O, the slot 217 comprises a curved ramp 231 and a straight vertical backstop support 233 (e.g., with no trumpeted section) to facilitate insertion of the curved distal end portion 227 of the J-stylet 214. As indicated above, the curved cannula 212 includes the rigid support portion 223 extending into and out of the threaded shaft portion 220 to provide additional support upon insertion of the J-stylet 214 within the central lumen of the curved cannula 212.

[0096] FIGURES 3P and 3Q illustrate insertion of the curved cannula assembly 210 into the introducer cannula 112. The curved distal end portion 225 of the curved cannula assembly 210 is inserted from a side angle (e.g., at about a 65 to 75 degree angle (such as a 70 degree starting angle in one embodiment) with respect to the central longitudinal axis LA of the distal hypotube 118 of the introducer cannula 112) into the slot 117 and along the ramp 141 in the proximal handle 116 and then down the central lumen of the distal hypotube 118



of the introducer cannula 112 while the gear wheel 221 of the curved cannula 212 is in a distal-most position along the threaded proximal portion 220 of the curved cannula 212 so as to prevent inadvertent advancement of the curved distal portion of the curved cannula assembly 210 beyond the open distal tip 122 of the introducer cannula 112 until the operator is ready to do so.

[0097] **FIGURE 3Q** is a close-up side cross-section view of the proximal portion of the introducer cannula 112 and the curved distal portion of the curved cannula assembly 210 and illustrates insertion of the curved distal end portions of the assembled components of the curved cannula assembly 210 into the introducer cannula 112. As shown, the introducer cannula 112 is shaped so as to provide a backstop support 143 generally aligned with the inner surface of the central lumen of the hypotube 118 so as to facilitate insertion and so that the curved distal end portion 225 of the distal polymeric shaft portion 224 of the curved cannula 212 does not pivot out of the introducer cannula 112 upon insertion. In accordance with several embodiments, the asymmetric “D-shaped” cross-sectional profile of the J-stylet 214 is advantageously designed to prevent twisting during insertion.

[0098] **FIGURES 3R and 3S** illustrate operation of the gear wheel 221 of the curved cannula 212. As shown in **FIGURE 3R**, the gear wheel 221 is rotated until it is in its distal-most position along the threaded proximal portion 220 prior to insertion of the curved cannula assembly 210 within the introducer cannula 112 so as to prevent inadvertent advancement of the curved distal end portions 225, 227 of the curved cannula assembly 210 out of the introducer cannula 112. As shown in **FIGURE 3S**, the gear wheel 221 is rotated to its proximal-most position along the threaded proximal portion 220 to enable full insertion of the curved cannula assembly 210 within the introducer cannula 112 such that the curved distal end portions 225, 227 of the curved cannula assembly 210 extend out of the introducer cannula 112 and along a curved path within the cancellous bone region of the vertebral body or other bone.

[0099] **FIGURES 3T and 3U** illustrate operation of a bail mechanism of the J-stylet 214. The proximal handle 226 of the J-stylet 214 includes a bail actuator 250 configured to be toggled between a first “resting” or “inactive” configuration in which the bail actuator 250 is generally aligned with (e.g., parallel or substantially parallel to) the upper surface of the proximal handle 226 (as shown in **FIGURE 3T**) and a second “active”

configuration in which the bail actuator 250 is offset from the upper surface of the proximal handle 226 (as shown in **FIGURE 3U**). The bail actuator 250 is configured to act as a lever to cause a slight axial (proximal-distal) movement of the J-stylet 214 with respect to the curved cannula 212 as the bail actuator 250 is pivoted. When the bail actuator 250 is toggled to the “active” configuration, a flange 253 of the bail actuator 250 contacts the proximal handle 216 of the curved cannula to cause proximal retraction of the J-stylet 214 with respect to the curved cannula 212 such that the distal channeling tip 228 of the J-stylet 214 resides completely within the curved cannula 212 and does not extend out of the open distal tip of the curved cannula 212. In accordance with several embodiments, the bail actuator 250 is advantageously toggled to the “active” configuration (in which the distal channeling tip 228 of the J-stylet 214 resides within the open distal tip of the curved cannulas 212) upon insertion and removal of the curved cannula assembly 210 from the introducer cannula 112 or the J-stylet 214 from the curved cannula 212 (e.g., so as to avoid friction caused by interaction between two metal components). The upper surface of the bail actuator 250 may include an indicator 252 (e.g., colored marking or other visual indicator) that is visible to an operator when the bail actuator 250 is in the active configuration and hidden when the bail actuator 250 is in the inactive configuration.

[0100] **FIGURE 3V** illustrates a side view of an embodiment of the straight stylet 314 and **FIGURE 3W** illustrates a distal portion of the straight stylet 314. The straight stylet 314 includes a proximal handle 316 and a distal elongate shaft 318. The proximal handle 316 includes an upper surface adapted for malleting by a mallet or application of pressure by a hand or fingers of an operator. A radiopaque marker band 317 may be positioned along the distal elongate shaft 318 at a position corresponding to the position when a distal channeling tip 319 of the straight stylet 314 is exiting the open distal tip of the curved cannula 212 as the straight stylet 314 is advanced through the curved cannula 212. The length of the straight stylet 314 may be sized such that, when the straight stylet 314 is fully inserted within the curved cannula 212, the length of the portion of the straight stylet 314 extending beyond the open distal tip of the curved cannula 212 is between 25 and 50 mm (e.g., between 25 mm and 35 mm, between 30 mm and 40 mm, between 35 mm and 45 mm, between 40 and 50 mm, overlapping ranges thereof, or any value within the recited ranges). The diameter of the

straight stylet 314 is sized so as to be inserted within and through the central lumen of the curved cannula 212.

[0101] The distal elongate shaft 318 comprises an inner flexible, shape memory core 360 extending from the proximal handle 316 to the distal channeling tip 319 of the straight stylet 314 and a polymeric outer layer 365 extending from the proximal handle 316 to a distal end of the distal elongate shaft 318 but stopping short (or proximal to) the distal channeling tip 319 so that the inner core 360 protrudes out of the outer layer 365. The straight stylet 314 is flexible enough to bend to traverse the curved distal end portion 225 of the curved cannula 212 without significant friction but sufficiently rigid so as to maintain a straight path once the straight stylet 314 exits the open distal tip of the curved cannula 212. The inner core 360 of the straight stylet 314 may comprise nitinol or other metallic alloy or other flexible material. The outer layer 365 may be comprised of a more rigid, polymeric material (such as PEEK, polyurethane, PET, and/or the like).

[0102] FIGURES 3X-3Z illustrate an embodiment of an introducer drill 440 and its interaction with the introducer cannula 112. A kit or system of access instruments (e.g., a kit or kit module designed for accessing hard, or high-density, bone) may optionally include the introducer drill 440. FIGURE 3X is a side view of an embodiment of the introducer drill 440. The introducer drill 440 includes a proximal handle 446 and an elongate drill shaft 447. The proximal handle 446 may comprise a generally T-shaped design and may comprise a soft-grip overmolding. The length of the elongate drill shaft 447 may be sized so as to extend from 20 mm to 35 mm beyond the open distal tip of the introducer cannula 112 when the introducer drill 440 is fully inserted within the introducer cannula 112. The elongate drill shaft 447 may include a solid proximal portion 448 and a fluted distal portion 449.

[0103] FIGURE 3Y is a close-up perspective view of the fluted distal portion 449. The fluted distal portion 449 may comprise a distal cutting tip 450 having a 90 degree cutting angle. The drill flutes 452 of the fluted distal portion 449 may be adapted to taper away from the distal cutting tip 450 (which is a reverse taper or opposite the direction of taper of a typical drill bit) so as to facilitate improved bone chip packing within the open flute volume as bone chips and fragments are generated by operation of the introducer drill 440. The distal cutting tip 450 may have a point angle of between 65 and 75 degrees and a chisel edge angle of between 115 and 125 degrees. The flutes may advantageously be deeper

and wider than typical drill bits because the elongate drill shaft 447 is supported by a rigid introducer cannula 112 surrounding at least a portion of the length of the elongate drill shaft (and a portion of the length of the fluted distal portion in most instances) during use. The drill flutes 452 may have a helix angle of between 12 degrees and 18 degrees (e.g., between 12 degrees and 14 degrees, between 13 degrees and 17 degrees, between 14 degrees and 16 degrees, between 14 degrees and 18 degrees, overlapping ranges thereof, or any value within the recited ranges). The fluted distal portion 449 may include two flutes having a length of between 70 mm and 85 mm.

[0104] The open flute volume of the fluted distal portion 449 may be advantageously configured to hold all or substantially all (e.g., more than 75%, more than 80%, more than 85%, more than 90%) of the significantly-sized bone chips or fragments removed by the introducer drill 440 as the introducer drill 440 is removed from the introducer cannula 112, thereby reducing the bone fragments left behind in the bone (e.g., vertebral body) or in the introducer cannula 112. In some embodiments, the open flute volume of the fluted distal portion 449 is adapted to hold about 2 ccs of bone. The fluted distal portion 449 may exhibit web tapering (e.g., increase in width or depth, or angle with respect to longitudinal axis of the flutes) along its length from distal to proximal (e.g., reverse taper). There may be no web taper for approximately the first 25 mm at the distal-most region. The web taper may then increase gradually until a maximum web taper is reached near the proximal end of the fluted distal portion 449 so as to facilitate pushing of the bone fragments or chip upward (or proximally) along the fluted distal portion 449. For example, the fluted distal portion 449 may have a negative draft (e.g., 0.77" or ~20 mm negative draft).

[0105] FIGURE 3Z illustrates the introducer drill 440 fully inserted and engaged with the proximal handle 116 of the introducer cannula 112. The introducer drill 440 is sized so as to be inserted within the central opening 120 of the proximal handle 116 of the introducer cannula 112 and advanced through the central lumen of the hypotube 118 of the introducer cannula 112. The proximal handle 446 of the introducer drill 440 is configured to engage with the coupling or mating features 121 of the proximal handle 116.

[0106] FIGURES 3AA – 3II illustrate an embodiment of steps of a method of using the access tools to facilitate access to a location within a vertebral body 500 for treatment (e.g., modulation of intraosseous nerves, such as a basivertebral nerve, bone

cement delivery for treatment of vertebral fractures, and/or ablation of bone tumors). With reference to **FIGURE 3AA**, the distal portion of the introducer assembly 110 (including the distal tip 125 of the introducer stylet 114 and the distal tip of the introducer cannula 112) are inserted through a pedicle 502 adjacent the vertebral body 500 by malleting on the proximal handle of the introducer stylet 114 after insertion and aligned engagement of the introducer stylet 114 within the introducer cannula 112.

[0107] In accordance with several embodiments, the method may optionally include removing the introducer stylet after initial penetration into the pedicle 502 (for example, if the operator can tell that the density of the bone is going to be sufficiently dense or hard that additional steps and/or tools will be needed to obtain a desired curved trajectory to access a posterior portion (e.g., posterior half) of the vertebral body 500. With reference to **FIGURE 3BB**, the method may optionally include inserting the introducer drill 440 into and through the introducer cannula 112 to complete the traversal of the pedicle 502 and penetration through a cortical bone 503 region of the vertebral body 500 until a cancellous bone region 504 of the vertebral body 500 is reached. The introducer drill 550 may be advanced into the cancellous bone region 504 (especially if the cancellous bone region 504 is determined to be sufficiently hard or dense) or the advancement may stop at the border between the cortical bone region 503 and the cancellous bone region 504. This step may involve both rotating the introducer drill 440 and malleting on the proximal handle 446 of the introducer drill 440 or simply rotating the introducer drill 440 without malleting on the proximal handle 446. With reference to **FIGURE 3CC**, the introducer drill 440 may be removed and the introducer stylet 114 may be re-inserted within the introducer cannula 112. With reference to **FIGURE 3DD**, the introducer assembly 110 may then be malleted so as to advance the distal tip 122 of the introducer cannula 112 to the entry site into (or within) the cancellous bone region 504 of the vertebral body 500. The introducer stylet 114 may then be removed from the introducer cannula 112.

[0108] The curved cannula assembly 210 may then be inserted within the introducer cannula 112 with the gear wheel 221 in the distal-most position so as to prevent inadvertent advancement of the curved cannula assembly 210 out of the open distal tip 122 of the introducer cannula 112 prematurely. With reference to **FIGURE 3EE**, after rotation of the gear wheel 221 to a more proximal position, the curved cannula assembly 210 can be

malleted so as to advance the collective curved distal end portions of the curved cannula assembly 210 together out of the distal tip 122 of the introducer cannula 112 and along a curved path within the cancellous bone region 504. With reference to **FIGURE 3FF**, the J-stylet 214 may then be removed from the curved cannula 212, with the curved cannula 212 remaining in position. In accordance with several embodiments, the path formed by the prior instruments may advantageously allow the curved cannula assembly 210 to have a head start and begin curving immediately upon exiting the open distal tip 122 of the introducer cannula 112.

[0109] With reference to **FIGURE 3GG**, if a further straight path beyond the curved path is desired to reach a target treatment location, the straight stylet 314 may be inserted through the curved cannula 212 such that the distal channeling tip 319 of the straight stylet extends beyond the open distal tip of the curved cannula 212 and along a straight path toward the target treatment location (e.g., a basivertebral nerve trunk or basivertebral foramen). In some embodiments, the straight stylet 314 may not be needed and this step may be skipped.

[0110] With reference to **FIGURE 3HH**, a treatment device 501 (e.g., a flexible bipolar radiofrequency probe) may be inserted through the curved cannula 212 (after removal of the straight stylet 314 if used) and advanced out of the open distal tip of the curved cannula 212 to the target treatment location. The treatment device 501 may then perform the desired treatment. For example, if the treatment device 501 is a radiofrequency probe, the treatment device 501 may be activated to ablate intraosseous nerves (e.g., a basivertebral nerve) or a tumor within the vertebral body 500. Bone cement or other agent, or a diagnostic device (such as a nerve stimulation device or an imaging device to confirm ablation of a nerve) may optionally be delivered through the curved cannula 212 after the treatment device 501 is removed from the curved cannula 212.

[0111] At certain levels of the spine (e.g., sacral and lumbar levels) and for certain patient spinal anatomies that require a steeper curve to access a desired target treatment location within the vertebral body, a combination curette/curved introducer may first be inserted to start a curved trajectory (e.g., create an initial curve or shelf) into the vertebra. The curette may have a pre-curved distal end portion or be configured such that the distal end portion can be controllably articulated or curved (e.g., manually by a pull wire or

rotation of a handle member coupled to one or more pull wires coupled to the distal end portion or automatically by a robotic or artificial intelligence driven navigation system). The combination curette/curved introducer may then be removed and the outer straight cannula and inner curved cannula/curved stylet assembly may then be inserted to continue the curve toward the target treatment location.

[0112] In accordance with several implementations, any of the access tools (e.g., cannula or stylet) or treatment devices may comprise a rheological and/or magnetizable material (e.g., magnetorheological fluid) along a distal end portion of the access tool that is configured to be curved *in situ* after insertion to a desired location within bone (e.g., vertebra). A magnetic field may be applied to the distal end portion of the access tool and/or treatment device with the magnetizable fluid or other material and adjusted or varied using one or more permanent magnets or electromagnets to cause the distal end portion of the access tool and/or treatment device to curve toward the magnetic field. In some implementations, a treatment probe may include a magnetic wire along a portion of its length (e.g., a distal end portion). Voltage applied to the magnetic wire may be increased or decreased to increase or decrease a curve of the magnetic wire. These implementations may advantageously facilitate controlled steering without manual pull wires or other mechanical mechanisms. The voltage may be applied by instruments controlled and manipulated by an automated robotic control system, such as the robotic system described in connection with FIGURE 7.

[0113] The treatment devices (e.g., treatment probes) may be any device capable of modulating tissue (e.g., nerves, tumors, bone tissue). Any energy delivery device capable of delivering energy can be used (e.g., RF energy delivery devices, microwave energy delivery devices, laser devices, infrared energy devices, other electromagnetic energy delivery devices, ultrasound energy delivery devices, and the like). The treatment device 501 may be an RF energy delivery device. The RF energy delivery device may include a bipolar pair of electrodes at a distal end portion of the device. The bipolar pair of electrodes may include an active tip electrode and a return ring electrode spaced apart from the active tip electrode. The RF energy delivery device may include one or more temperature sensors (e.g., thermocouples, thermistors) positioned on an external surface of, or embedded within, a

shaft of the energy delivery device. The RF energy delivery device may not employ internally circulating cooling, in accordance with several implementations.

[0114] In some implementations, water jet cutting devices may be used to modulate (e.g., denervate) nerves. For example, a water jet cutter may be configured to generate a very fine cutting stream formed by a very high-pressure jet of water. For example, the pressure may be in the range of 15 MPa to 500 MPa (e.g., 15 MPa to 50MPa, 30 MPa – 60 MPa, 50 MPa – 100 MPa, 60 MPa – 120 MPa, 100 MPa – 200 MPa, 150 MPa – 300 MPa, 300 MPa – 500 MPa, overlapping ranges thereof, or any value within the recited ranges). In some implementations, a chemical neuromodulation tool injected into a vertebral body or at an endplate may be used to ablate or otherwise modulate nerves or other tissue. For example, the chemical neuromodulation tool may be configured to selectively bind to a nerve or endplate. In some implementations, a local anesthetic (e.g., liposomal local anesthetic) may be used inside or outside a vertebral body or other bone to denervate or block nerves. In some implementations, brachytherapy may be used to place radioactive material or implants within the vertebral body to deliver radiation therapy sufficient to ablate or otherwise denervate the vertebral body. In some implementations, chymopapain injections and/or condoliase injections may be used (e.g., under local anesthesia). Phototherapy may be used to ablate or otherwise modulate nerves after a chemical or targeting agent is bound to specific nerves or to a vertebral endplate.

[0115] In accordance with several implementations, thermal energy may be applied within a cancellous bone portion (e.g., by one or more radiofrequency (RF) energy delivery instruments coupled to one or more RF generators) of a vertebral body. The thermal energy may be conducted by heat transfer to the surrounding cancellous bone, thereby heating up the cancellous bone portion. In accordance with several implementations, the thermal energy is applied within a specific frequency range and having a sufficient temperature and over a sufficient duration of time to heat the cancellous bone such that the basivertebral nerve extending through the cancellous bone of the vertebral body is modulated. In several implementations, modulation comprises permanent ablation or denervation or cellular poration (e.g., electroporation). In some implementations, modulation comprises temporary denervation or inhibition. In some implementations, modulation comprises stimulation or denervation without necrosis of tissue.



[0116] For thermal energy, temperatures of the thermal energy may range from about 70 to about 115 degrees Celsius (e.g., from about 70 to about 90 degrees Celsius, from about 75 to about 90 degrees Celsius, from about 83 to about 87 degrees Celsius, from about 80 to about 100 degrees Celsius, from about 85 to about 95 degrees Celsius, from about 90 to about 110 degrees Celsius, from about 95 to about 115 degrees Celsius, or overlapping ranges thereof). The temperature ramp may range from 0.1 – 5 degrees Celsius/second (e.g., 0.1 – 1.0 degrees Celsius/second, 0.25 to 2.5 degrees Celsius/second, 0.5 – 2.0 degrees Celsius/second, 1.0 – 3.0 degrees Celsius/second, 1.5 – 4.0 degree Celsius/second, 2.0 – 5.0 degrees Celsius/second). The time of treatment may range from about 10 seconds to about 1 hour (e.g., from 10 seconds to 1 minute, 1 minute to 5 minutes, from 5 minutes to 10 minutes, from 5 minutes to 20 minutes, from 8 minutes to 15 minutes, from 10 minutes to 20 minutes, from 15 minutes to 30 minutes, from 20 minutes to 40 minutes, from 30 minutes to 1 hour, from 45 minutes to 1 hour, or overlapping ranges thereof). Pulsed energy may be delivered as an alternative to or in sequence with continuous energy. For radiofrequency energy, the energy applied may range from 350 kHz to 650 kHz (e.g., from 400 kHz to 600 kHz, from 350 kHz to 500 kHz, from 450 kHz to 550 kHz, from 500 kHz to 650 kHz, overlapping ranges thereof, or any value within the recited ranges, such as 450 kHz  $\pm$  5 kHz, 475 kHz  $\pm$  5 kHz, 487 kHz  $\pm$  5 kHz). A power of the radiofrequency energy may range from 5 W to 30 W (e.g., from 5 W to 15 W, from 5 W to 20 W, from 8 W to 12 W, from 10 W to 25 W, from 15 W to 25 W, from 20 W to 30 W, from 8 W to 24 W, and overlapping ranges thereof, or any value within the recited ranges). In accordance with several implementations, a thermal treatment dose (e.g., using a cumulative equivalent minutes (CEM) 43 degrees Celsius thermal dose calculation metric model) is between 200 and 300 CEM (e.g., between 200 and 240 CEM, between 230 CEM and 260 CEM, between 240 CEM and 280 CEM, between 235 CEM and 245 CEM, between 260 CEM and 300 CEM) or greater than a predetermined threshold (e.g., greater than 240 CEM). The CEM number may represent an average thermal cumulative dose value at a target treatment region or location and may represent a number that expresses a desired dose for a specific biological end point. Thermal damage may occur through necrosis or apoptosis.

[0117] Cooling may optionally be provided to prevent surrounding tissues from being heated during the nerve modulation procedure. The cooling fluid may be internally

circulated through the delivery device from and to a fluid reservoir in a closed circuit manner (e.g., using an inflow lumen and an outflow lumen). The cooling fluid may comprise pure water or a saline solution having a temperature sufficient to cool electrodes (e.g., 2 – 10 degrees Celsius, 5 – 10 degrees Celsius, 5 – 15 degrees Celsius). Cooling may be provided by the same instrument used to deliver thermal energy (e.g., heat) or a separate instrument. In accordance with several implementations, cooling is not used.

[0118] In some implementations, ablative cooling may be applied to the nerves or bone tissue instead of heat (e.g., for cryoneurolysis or cryoablation applications). The temperature and duration of the cooling may be sufficient to modulate intraosseous nerves (e.g., ablation, or localized freezing, due to excessive cooling). The cold temperatures may destroy the myelin coating or sheath surrounding the nerves. The cold temperatures may also advantageously reduce the sensation of pain. The cooling may be delivered using a hollow needle under fluoroscopy or other imaging modality.

[0119] In some implementations, one or more fluids or agents may be delivered to a target treatment site to modulate a nerve. The agents may comprise bone morphogenetic proteins, for example. In some implementations, the fluids or agents may comprise chemicals for modulating nerves (e.g., chemoablative agents, alcohols, phenols, nerve-inhibiting agents, or nerve stimulating agents). The fluids or agents may be delivered using a hollow needle or injection device under fluoroscopy or other imaging modality.

[0120] One or more treatment devices (e.g., probes) may be used simultaneously or sequentially. For example, the distal end portions of two treatment devices may be inserted to different locations within a vertebral body or other bone or within different vertebral bodies or bones. Radiofrequency treatment probes may include multiple electrodes configured to act as monopolar, or unipolar, electrodes or as pairs of bipolar electrodes. The treatment device(s) may also be pre-curved or curveable such that the curved stylet is not needed or may have sharp distal tips such that additional sharpened stylets are not needed. In some implementations, any or all of the access tools and the treatment devices are MR-compatible so as to be visualized under MR imaging.

[0121] The one or more treatment devices (e.g., probes such as radiofrequency probes, treatment device 501 of a kit or system) may include an indicator configured to alert a clinician as to a current operation state of the treatment device. For example, the indicator

may include a light ring disposed along a length of, and extending around a circumference of, the treatment device. The light ring may be configured to light up with different colors and/or exhibit other visible effects (e.g., pulsing on and off with certain patterns). The one or more treatment devices may also be configured to provide audible alerts (e.g., beeps having a certain frequency or intonation) corresponding to different operational states. In one implementation, the light ring may be dark or not lit up when the treatment device is not connected to a radiofrequency generator or not ready for RF energy delivery. The light ring may pulse at a first rate (e.g., 1 pulse every 2-3 seconds) to indicate an operational state in which the treatment device and generator system are ready to initiate RF energy delivery. The light ring may be continuously lit up to indicate an operational state in which the treatment device is actively delivering RF energy. The light ring may pulse at a second rate different than (e.g., faster than, slower than) the first rate to indicate an operational state in which an error has been detected by the generator or if a particular treatment parameter is determined to be outside an acceptable range of values. In one implementation, the second rate is greater than the first rate (e.g., 2 pulses per second). Haptic feedback may also be provided to the clinician for at least some of the operational states to provide a further alert in addition to a visible alert.

[0122] In some implementations, the treatment device (e.g., treatment device 501) includes a microchip that is pre-programmed with treatment parameters (e.g., duration of treatment, target temperature, temperature ramp rate). Upon electrical connection of the treatment device to the generator, the treatment parameters are transmitted to the generator and displayed on a display of the generator to provide confirmation of desired treatment to a clinician.

[0123] **FIGURE 4** illustrates a front view of an embodiment of a generator 400 (e.g., radiofrequency energy generator). The generator 400 includes an instrument connection port 405 to which a treatment device (e.g., RF energy delivery probe) may be connected. The generator 400 may be configured for use without a neutral electrode (e.g., grounding pad). The instrument connection port 605 is surrounded by an indicator light 406 configured to illuminate when the treatment device is properly connected to the instrument connection port 405. As shown, the indicator light 406 may comprise a circular LED indicator light. The indicator light 406 may be configured to continuously illuminate in a

solid color (e.g., white, blue, green) when a treatment device is connected to the instrument connection port 405. The indicator light 406 may flash at a first pulsing rate (e.g., 1 Hz) to prompt a clinician to connect the treatment device to the instrument connection port 405. The indicator light 406 may flash at a second pulsing rate different than (e.g., faster than) the first pulsing rate (e.g., 2 Hz, 3 Hz, 4 Hz) to indicate an error condition.

[0124] The generator 400 also includes a display 408 configured to display information to the clinician or operator. During startup and use, the current status of the generator 400 and energy delivery (treatment) parameters may be displayed on the display 408. During energy delivery, the display 408 may be configured to display remaining treatment time, temperature, impedance, and power information (alphanumerically and/or graphically). For example, graphical representations of power vs. time and impedance vs. time may be displayed. In one implementation, the display may comprise a color, active matrix display. The generator 400 further includes a start/pause button 410 configured to be pressed by an operator to initiate and stop energy delivery. Similar to the indicator light 406 surrounding the instrument connection port 405, a second indicator light 412 may surround the start/pause button 410. The second indicator light 412 may also comprise a circular LED indicator light. The second indicator light 412 may be configured to continuously illuminate in a solid color (e.g., white, blue, green) when the generator 400 is powered on and ready to initiate energy delivery. The indicator light 412 may flash at a first pulsing rate (e.g., 1 Hz) to prompt a clinician to press the start/pause button 410 to initiate energy delivery. The indicator light 412 may flash at a second pulsing rate different than (e.g., faster than) the first pulsing rate (e.g., 2 Hz, 3 Hz, 4 Hz) when energy delivery has been paused or stopped. The generator 400 may also be configured to output audible alerts indicative of the different operating conditions (e.g., to coincide with the output of the indicator lights 406, 412).

[0125] The generator 400 may also include a power button 414 configured to power on and off the generator 400, a standby power indicator light 416 configured to illuminate (e.g., in solid green color) when an AC power switch (not shown) of the generator 400 is switched on, an RF active indicator light 417 configured to illuminate (e.g., in solid blue color) during RF energy delivery, and a system fault indicator light 418 configured to illuminate (e.g., in solid red color) during a system fault condition. The generator 400 may also include user input buttons 420 configured to facilitate navigation and selection of

options (e.g., menu options, configuration options, acknowledgement requests) that appear on the display 408 (e.g., arrow buttons to toggle up and down between options and an “enter” button for user selection of a desired option).

#### **Access to Locations Outside Vertebral Body**

[0126] For access to locations outside bone (e.g., extraosseous locations, such as outside a vertebral body), visualization or imaging modalities and techniques may be used to facilitate targeting. For example, a foramen of a vertebral body (e.g., basivertebral foramen) may be located using MRI guidance provided by an external MR imaging system, CT guidance provided by an external tomography imaging system, fluoroscopic guidance using an external X-ray imaging system, and/or an endoscope inserted laparoscopically. Once the foramen is located, therapy (e.g., heat or energy delivery, chemoablative agent delivery, cryotherapy, brachytherapy, and/or mechanical severing) may be applied to the foramen sufficient to modulate (e.g., ablate, denervate, stimulate) any nerves entering through the foramen. For example, an endoscope may be used to locate the foramen under direct visualization and then the basivertebral nerve may be mechanically transected near the foramen. In some implementations, an intervertebral disc and vertebral body may be denervated by treating (e.g., ablating) a sinuvertebral nerve prior to the sinuvertebral nerve branching into the basivertebral nerve that enters the basivertebral foramen of the vertebral body. Because vertebral endplates are cartilaginous, radiation or high-intensity focused ultrasound energy may be applied to vertebral endplates from a location external to a subject’s body altogether to denervate nerves in the vertebral endplates.

#### **TARGET IDENTIFICATION AND PATIENT SCREENING**

[0127] In accordance with several implementations, target, or candidate, vertebrae for treatment can be identified prior to treatment. The target, or candidate, vertebrae may be identified based on identification of various types of, or factors associated with, endplate degeneration and/or defects (e.g., focal defects, erosive defects, rim defects, corner defects, all of which may be considered pre-Modic change characteristics). For example, one or more imaging modalities (e.g., MRI, CT, X-ray, fluoroscopic imaging) may be used to determine whether a vertebral body or vertebral endplate exhibits active Modic characteristics or “pre-Modic change” characteristics (e.g., characteristics likely to result in

Modic changes, such as Type 1 Modic changes that include findings of inflammation and edema or type 2 Modic changes that include changes in bone marrow (e.g., fibrosis) and increased visceral fat content). For example, images obtained via MRI (e.g., IDEAL MRI) may be used to identify (e.g., via application of one or more filters) initial indications or precursors of edema or inflammation at a vertebral endplate prior to a formal characterization or diagnosis as a Type 1 Modic change. Examples of pre-Modic change characteristics could include mechanical characteristics (e.g., loss of soft nuclear material in an adjacent intervertebral disc of the vertebral body, reduced disc height, reduced hydrostatic pressure, microfractures, focal endplate defects, erosive endplate defects, rim endplate defects, corner endplate defects, osteitis, spondylodiscitis, Schmorl's nodes) or bacterial characteristics (e.g., detection of bacteria that have entered an intervertebral disc adjacent to a vertebral body, a disc herniation or annulus tear which may have allowed bacteria to enter the intervertebral disc, inflammation or new capillarisation that may be caused by bacteria) or other pathogenetic mechanisms that provide initial indications or precursors of potential Modic changes or vertebral endplate degeneration or defects.

[0128] Accordingly, vertebral bodies may be identified as target candidates for treatment before Modic changes occur (or before painful symptoms manifest themselves to the patient) so that the patients can be proactively treated to prevent, or reduce the likelihood of, chronic low back pain before it occurs. In this manner, the patients will not have to suffer from debilitating lower back pain for a period of time prior to treatment. Modic changes may or may not be correlated with endplate defects and may or may not be used in candidate selection or screening. In accordance with several embodiments, Modic changes are not evaluated and only vertebral endplate degeneration and/or defects (e.g., pre-Modic change characteristics prior to onset or prior to the ability to identify Modic changes) are identified. Rostral and/or caudal endplates may be evaluated for pre-Modic changes (e.g., endplate defects that manifest before Modic changes that may affect subchondral and vertebral bone marrow adjacent to a vertebral body endplate).

[0129] In some implementations, a level of biomarker(s) (e.g., substance P, cytokines, high-sensitivity C-reactive protein, or other compounds associated with inflammatory processes and/or pain and/or that correlate with pathophysiological processes associated with vertebral endplate degeneration or defects (e.g., pre-Modic changes) or

Modic changes such as disc resorption, Type III and Type IV collagen degradation and formation, or bone marrow fibrosis) may be obtained from a patient (e.g., through a blood draw (e.g., blood serum) or through a sample of cerebrospinal fluid) to determine whether the patient is a candidate for basivertebral nerve ablation treatment (e.g., whether they have one or more candidate vertebral bodies exhibiting factors or symptoms associated with endplate degeneration or defects (e.g., pre-Modic change characteristics)). Cytokine biomarker samples (e.g., pro-angiogenic serum cytokines such as vascular endothelial growth factor (VEGF)-C, VEGF-D, tyrosine-protein kinase receptor 2, VEGF receptor 1, intercellular adhesion molecule 1, vascular cell adhesion molecule 1) may be obtained from multiple different discs or vertebral bodies or foramina of the patient and compared with each other in order to determine the vertebral bodies to target for treatment. Other biomarkers may be assessed as well, such as neo-epitopes of type III and type IV pro-collagen (e.g., PRO-C3, PRO-C4) and type III and type IV collagen degradation neo-epitopes (e.g., C3M, C4M).

[0130] In some implementations, samples are obtained over a period of time and compared to determine changes in levels over time. For example, biomarkers may be measured weekly, bi-monthly, monthly, every 3 months, or every 6 months for a period of time and compared to analyze trends or changes over time. If significant changes are noted between the biomarker levels (e.g., changes indicative of endplate degeneration or defects (e.g., pre-Modic change characteristics) or Modic changes, as described above), treatment may be recommended and performed to prevent or treat back pain. Biomarker levels (e.g., substance P, cytokine protein levels, PRO-C3, PRO-C4, C3M, C4M levels) may be measured using various *in vivo* or *in vitro* kits, systems, and techniques (e.g., radio-immunoassay kits/methods, enzyme-linked immunosorbent assay kits, immunohistochemistry techniques, array-based systems, bioassay kits, *in vivo* injection of an anticytokine immunoglobulin, multiplexed fluorescent microsphere immune-assays, homogeneous time-resolved fluorescence assays, bead-based techniques, interferometers, flow cytometry, etc.). Cytokine proteins may be measured directly or indirectly, such as by measuring mRNA transcripts.

[0131] The identification of pre-Modic change characteristics may involve determining a quantitative or qualitative endplate score based on severity, extent, and/or quantity of the identified pre-Modic change characteristics (e.g., vertebral endplate defects) and vertebrae having a quantitative endplate score above a threshold may be deemed as

potential candidates for treatment (e.g., basivertebral nerve ablation). The pre-Modic change characteristics may be combined with age, gender, body mass index, bone mineral density measurements, back pain history, and/or other known risk factors for vertebral endplate degeneration or defects (such as smoking, occupational or recreational physical demands or situations) in identifying candidate patients and/or candidate vertebral bodies for treatment (e.g., basivertebral nerve ablation).

## **LESION SHAPING AND FORMATION**

### **Shaping**

[0132] In some implementations, a target treatment region within a vertebral body may be clarified using pre-operative imaging (e.g., using bilateral fluoroscopy images or both anterior-posterior and lateral fluoroscopy images) of the vertebral body. The target treatment region may be identified as where a tip of a channeling stylet transects a basivertebral foramen (based on the images). In some implementations, an ideal target treatment region may be located at or about 1 cm from a posterior wall of the vertebral body (e.g., between 10 mm and 11 mm, between 10.5 mm and 11.5 mm, 10 mm, 10.5 mm, 11 mm, 11.5 mm). For certain vertebral body levels, it may be desirable to target an edge of a safety boundary.

[0133] In accordance with several implementations, lesion zones, or ablation zones, may advantageously be preferentially shaped to provide sufficient coverage to ablate a basivertebral nerve or other intraosseous nerve but not permanently ablate or damage surrounding or adjacent tissue, thereby minimizing extent of injury or damage. The shape of the lesion zone may be preferentially shaped by providing specific energy treatment algorithms or recipes. For example, a certain amount of power may be applied to heat a target treatment zone to within a certain temperature range for a period of time within a certain time range sufficient to form a lesion zone that ablates a targeted nerve within bone (e.g., basivertebral nerve) but limits the size of the lesion zone to isolate the nerve (e.g., a focused or targeted lesion zone).

[0134] In implementations involving radiofrequency energy delivery devices, multiple different sized electrodes may be included along the device and/or the layout of the electrodes may be varied to increase a diameter and/or length (e.g., major diameter along a



long axis of the zone and/or minor diameter along a short axis of the zone) or otherwise adjust a shape of a lesion zone. The frequency applied to the electrodes, the power applied to the electrodes, the target temperature, cooling of the electrodes, duration of treatment, and/or the length or diameter of the electrodes may be varied to vary an overall diameter or shape of a lesion. Pulsing of the applied power may also be used to change lesion shape. Power output may be adjusted based on real-time temperature measurements obtained from one or more temperature sensors positioned within and/or along the treatment device or in separate temperature probes inserted within the target treatment zone. The treatment device may also be moved (e.g., rotated and/or translated) at various times during the treatment procedure to affect lesion shape. In other words, the lesion shape may be controlled by rotational attributes. In some implementations, shaping of lesions is effected by controlling an amount of electrode surface area that is exposed (e.g., masking of electrodes to control delivery of energy). In accordance with several implementations, a thermal treatment dose (e.g., using a cumulative equivalent minutes (CEM) 43 degrees Celsius model) is between 200 and 300 CEM (e.g., between 200 and 240 CEM, between 230 CEM and 260 CEM, between 235 CEM and 245 CEM, between 240 CEM and 280 CEM, between 260 CEM and 300 CEM) or greater than a predetermined threshold (e.g., greater than 240 CEM).

[0135] In some implementations, a heating, or lesion, zone is established and controlled within a vertebral body so as not to heat any portion of the vertebral body within 1 cm of the posterior wall (e.g., posterior-most border) of the vertebral body. In some implementations, the targeted heating zone is maintained to a region that is between about 10% and about 80%, between about 5% and about 70%, between about 10% and about 65%, between about 20% and about 60%, between about 30% and about 55%, or overlapping ranges thereof, of the distance from the posterior wall to the anterior wall of the vertebral body. The heating zone may be specifically designed and configured to encompass a terminus of a basivertebral nerve or other intraosseous nerve (or of a basivertebral foramen). The terminus may be located approximately mid-body in the vertebral body (e.g., approximately 30%-50% across the sagittal vertebral body width). In various implementations, the heating zone may range from 8 mm to 20 mm (e.g., 8 to 10 mm, 10 to 12 mm, 11 to 13 mm, 12 to 14 mm, 13 to 15 mm, 14 to 20 mm, overlapping ranges thereof, or any value within the recited ranges) in maximum dimension (e.g., largest diameter).

[0136] In accordance with several embodiments, a desired target treatment location or region of a vertebral body may be any location at which 75% of the basivertebral nerve branches are sufficiently denervated (e.g., ablated) by applying a thermal treatment dose (e.g., using a cumulative equivalent minutes (CEM) 43 degrees Celsius model) of between 200 and 300 CEM (e.g., between 200 and 240 CEM, between 230 CEM and 260 CEM, between 235 CEM and 245 CEM, between 240 CEM and 280 CEM, between 260 CEM and 300 CEM) or greater than a predetermined threshold (e.g., greater than 240 CEM). In some embodiments, the desired target treatment location or region of a vertebral body is a location that is no more anterior than a location corresponding to 25% arborization of nerve branches of the basivertebral nerve from the exit point at the basivertebral foramen. Arborization may be defined by its ordinary meaning in a medical dictionary and may mean branching off of nerve branches from a main origin nerve (e.g., terminus or entry/exit point of a basivertebral nerve in a vertebral body). 25% arborization may mean that 25% of the total nerve branches within a particular vertebral body have branched off from a main origin nerve. In some embodiments, the desired target treatment location comprises a geometric center or midpoint of the vertebral body. The treatment (e.g., basivertebral nerve ablation) may be performed within multiple different vertebral bodies simultaneously or sequentially using the same parameters. The vertebral bodies may be adjacent or spaced-apart vertebral bodies of the same spine level or a different spine level (e.g., sacral, lumbar, thoracic, cervical).

[0137] In accordance with several embodiments, a thermal treatment dose (e.g., using a cumulative equivalent minutes (CEM) 43 degrees Celsius model) of between 200 and 300 CEM (e.g., between 200 and 240 CEM, between 230 CEM and 260 CEM, between 235 CEM and 245 CEM, between 240 CEM and 280 CEM, between 260 CEM and 300 CEM) or greater than a predetermined threshold (e.g., greater than 240 CEM) to form a lesion of a smallest volume that still achieves denervation (e.g., ablation) of 75% of the nerve branches of a basivertebral nerve within a vertebral body. For example, the lesion zone may form a 1 cm diameter sphere that may be elongated or adjusted so as to achieve the 75% denervation depending on the vertebral body characteristics (e.g., level, bone mass density, etc.). A major axis may be between 10 mm and 30 mm (e.g., between 10 mm and 20 mm, between 10 mm and 15 mm, between 15 mm and 25 mm, between 10 mm and 25 mm, between 15 mm

and 30 mm, overlapping ranges thereof or any value within the recited ranges) and a minor axis may be between 5 mm and 20 mm (e.g., between 5 mm and 10 mm, between 5 mm and 15 mm, between 8 mm and 15 mm, between 10 mm and 15 mm, between 15 mm and 20 mm, overlapping ranges thereof, or any value within the recited ranges). A major axis length to minor axis length ratio may be between 1:1 and 5:1 (e.g., between 1:1 and 2.5:1, between 1:1 and 2:1, between 1:1 and 3:1, between 1.5:1 and 3:1, between 2:1 and 4:1, overlapping ranges thereof, or any value within the recited ranges, such as 1.2:1, 1.8:1, 1.5:1, 2:1, 2.5:1, 3:1, 3.5:1, 4:1, 4.5:1, or 5:1).

[0138] The various treatment parameters described herein may be adjusted to effect a desired lesion shape. FIGURES 5A-5D illustrate various lesion shapes that may be generated by one or more treatment devices 712. For example, as shown in FIGURE 5A, a desired lesion shape may be football-shaped or elliptical-shaped to obtain more anterior-posterior coverage. In some implementations, medial-lateral coverage could be sacrificed to obtain more anterior-posterior coverage. The desired maximum length (dimension of longer axis) and width (dimension of shorter axis) of the football-shaped lesion may be, for example, 30 mm x 10 mm, 25 mm x 10 mm, 20 mm x 10 mm, 30 mm x 15 mm, 25 mm x 15 mm. In some implementations, the football-shaped lesion has a maximum length to maximum width ratio of about 1.8:1, 1.5:1, 2:1, 2.5:1, 3:1, 3.5:1, 4:1, 4.5:1, or 5:1. The lesion shape may be oval, elliptical (FIGURE 5B), cigar-shaped or disc-shaped (FIGURE 5C), UFO-shaped (FIGURE 5D), rectangular, X-shaped, cross-shaped, or amorphous in various embodiments.

[0139] Impedance may be monitored during energy delivery and if impedance is deemed to be outside of a safety threshold range, the energy delivery may be automatically terminated or an alert may be generated so as to prevent, or reduce the likelihood of occurrence of, charring. High impedance measurements may be triggered by increased blood flow in or near the treatment region, thereby resulting in undesired stoppages or interruptions in treatment even though these high impedance measurements do not present safety risks. In accordance with several implementations involving radiofrequency energy delivery devices, detection of regions of high blood flow in or near the target treatment region may be performed in order to position the electrodes in a location that does not have high blood flow in order to avoid these undesired interruptions in energy delivery once energy delivery is

initiated. In addition, blood flow may be detected and/or monitored during the treatment procedure and adjustments may be made to the energy delivery algorithm so as not to terminate or interrupt energy delivery when the “false positive” high impedance measurements are obtained as a result of increased blood flow. Multiple thermocouples may be positioned along a length of a treatment probe to steer the treatment probe toward or away from locations of high blood flow.

[0140] For implementations involving two treatment probes, each treatment probe can include two or more electrodes and voltage differentials may be applied between different pairs of electrodes on the two probes to adjust the shape of the lesion. The paired electrodes may vary or be toggled such that different pair combinations of electrodes are formed for various durations of time in a predetermined pattern or based on feedback from one or more sensors. The pairs of electrodes may include two electrodes on the same probe and/or two electrodes on different probes. In one implementation, a voltage differential may be applied between electrodes of the same probes for a certain duration and then the voltage differential may be applied between electrode “pairs” disposed on different probes for a certain duration. The durations may be the same or different, depending on the shape of the lesion desired. As an example of an implementation involving use of two probes each having two electrodes, a distal electrode of a first probe may be paired with a distal electrode of a second probe and a proximal electrode of the first probe may be paired with a proximal electrode of the second probe for a first duration of time. Then, the distal electrode of the first probe may be paired with the proximal electrode of the second probe and the distal electrode of the second probe may be paired with the proximal electrode of the first probe for a second duration of time. This pattern may be repeated multiple times over a total treatment duration. The energy delivery devices (e.g., probes) may be connected to a single energy source (e.g., generator) or separate energy sources (e.g., generators).

[0141] The durations may vary as desired and/or required (e.g., 20 seconds to 60 seconds, 30 seconds to 90 seconds, 45 seconds to 90 seconds, 1 minute to 2 minutes, 90 seconds to 3 minutes, 2 minutes to 4 minutes, 3 minutes to 5 minutes, 4 minutes to 6 minutes, 6 minutes to 15 minutes, overlapping ranges thereof, or any value within the recited ranges). The corresponding pairs of electrodes may be switched or toggled as many times as desired to form different lesion patterns and to adjust overall lesion shape.

[0142] Use of two devices or probes may advantageously form synergistic lesions that provide greater surface area or coverage (or the same amount of coverage or treatment efficacy but in a more efficient manner) than could be achieved by independent lesions formed by the separate devices or probes or by a single probe that is moved to different locations. In accordance with several embodiments, the use of two probes and switching patterns of energy delivery between pairs of electrodes may advantageously allow for replenishment of blood in the target treatment region to reduce impedance stoppages.

[0143] With reference to **FIGURE 6**, in implementations involving two treatment devices or probes, the access tools may include two cannulas or introducers 612 each having a radial, or lateral side, window 613 at its distal end and a curved or angled ramp 616 to guide a treatment probe 617 (e.g., treatment device 312) inserted therethrough in a curved or angled direction upon exiting the radial window 613. The windows 613 of the two introducers 612 may be positioned to face toward each other so that the treatment devices or probes 617 curve out of the radial windows 613 toward each other to more effectively control lesion formation and shape as opposed to two probes simply being inserted straight in to the vertebral body (e.g., through separate pedicles). In some implementations, the windows 613 of the introducers/cannulas 612 are visible under fluoroscopy or CT imaging so as to facilitate positioning within a vertebral body or other bone. The introducers 612 may be inserted in combination with an introducer stylet transpedicularly or extrapedicularly into the vertebral body. The introducer stylets may then be removed and the treatment devices or probes 617 then inserted. In some implementations, the introducers 612 have a sharp distal tip and introducer stylets are not required. In some implementations, initial paths are created through the cortical shell of the vertebral body by a separate access instrument and then the introducers 612 are introduced into the vertebral body.

[0144] Nerve detection and/or monitoring techniques may be performed during insertion of access tools or treatment devices to increase efficacy and/or targeting. Determined distances between the treatment device and target nerves may be used to adjust treatment parameters to increase efficacy of the treatment. For example, if it is determined from the techniques that a treatment device is in contact with a nerve or within a certain threshold distance from the nerve, ablation time duration may be decreased. However, if it is determined from the nerve detection and/or monitoring techniques that the treatment device

(e.g., energy delivery device) is greater than a threshold distance away from the nerve, the ablation time duration may not change or may be increased. The distance between (or contact between) the treatment device and the target nerve may be monitored intra-procedurally and parameters may be adjusted in real time.

[0145] The nerve detection techniques may be performed by a laparoscopic device (e.g., catheter or probe with one or multiple stimulation and/or sensory electrodes). The device may be manually controlled or robotically controlled (e.g., using a robotic system such as the robotic system described in connection with FIGURE 7). The device may be in electrical communication with an analyzer unit programmed to analyze signals from the device to determine the proximity of the device to the nerve. The analyzer unit may be coupled to an output device (such as a speaker or visual display with a graphical user interface) that is configured to output a quantitative or qualitative output indicative of proximity. The qualitative output may comprise a change in intensity, frequency, volume, or sound of an audible output or a change in color corresponding to distance on a visual display. The quantitative output may comprise actual numeric values of distances displayed on a display screen (e.g., display 408 of generator 400).

#### **Lesion Formation Assessment**

[0146] Lesion assessment may be performed in real-time during treatment to provide confirmation of treatment or other feedback to a clinician performing the treatment. For example, real-time input of lesion characteristics or lesion formation (e.g., size, temperature, tissue viability, nerve conduction) may be monitored to assure coverage and/or efficacy. Such techniques may advantageously provide intraoperative, real-time confirmation of ablation. Lesion characteristics may be obtained from a variety of sensors (e.g., temperature sensors, impedance sensors) and/or from intra-procedural images.

[0147] In some implementations, infrared sensing techniques may be performed to confirm that the treatment device is in a desired treatment location within the vertebral body or other bone and providing sufficient coverage to effect ablation of the basivertebral nerve or tumor without over-extending the coverage. For example, the lesion may be thermally mapped using multiple thermocouples (e.g., two, three, four, five, six, or more than six) positioned at different locations within the vertebral body or other bone and calculations using bioheat transfer equations may be performed by a computer or processor to transform

the measurements obtained from the multiple thermocouples into a graphical visualization of the lesion shape or zone in real time (e.g., thermal map). The graphical visualization, or thermal map, may be generated and displayed on a graphical user interface of a display device (e.g., display 608 of generator 600). Different colors may be used to represent different temperature ranges. The treatment procedure may be continued until the lesion reaches a certain desired size or shape as determined from the graphical visualization. The graphical visualization may be sufficiently sized such that it can be overlaid on top of actual anatomical images of the vertebral body so as to facilitate determination of proper lesion formation sufficient to ablate the basivertebral nerve within the vertebral body.

[0148] In some implementations, heat markers (e.g., temperature-dependent indicators) may be added to the target treatment zone that under MR or CT imaging manifest in a different way so that a clinician can visualize the lesion growing in real time. For example, once a particular temperature has been reached and maintained for an amount of time sufficient to ensure ablation, the heat marker may appear differently under imaging.

[0149] In other implementations, an ultrasound balloon catheter (e.g., having a sensor/emitter combination) may be inserted through one of the pedicles (e.g., on a contralateral side) to map water density changes during ablation, which would be indicative of ablation, edema, etc.

[0150] In some implementations, a high-frequency emitter and multiple thermocouples may be used to generate a radar map of bone that can be displayed on a display device (e.g., of the radiofrequency generator). In some implementations, a closed loop system may be employed in which a robotic controller is actively moving a device that changes configuration (e.g., based on artificial intelligence feedback). For example, a probe may be driven to a preselected target using imaging and live feedback.

[0151] In accordance with several implementations, biomarkers may be used to confirm treatment efficacy (e.g., whether the procedure resulted in effective ablation of a basivertebral nerve within a vertebral body or an intraosseous nerve within another bone and achieved a desirable therapeutic response). Biomarkers can include anatomical, physiological, biochemical, molecular parameters or imaging features that can be used to confirm treatment efficacy. Biomarkers can be detected and measured by a variety of methods, including but not limited to, physical examination, laboratory assays (such as blood

samples), and medical imaging. Biomarkers may be obtained via biological tissue sampling or in a minimally invasive manner (e.g., from blood, saliva, cerebrospinal fluid, or urine). Tissue imaging may also be used to detect and measure biomarkers. Biomarker levels (e.g., substance P or cytokine or heat shock protein levels) may be measured using various *in vivo* or *in vitro* (*ex vivo*) kits, systems, and techniques (e.g., radio-immunoassay kits/methods, enzyme-linked immunosorbent assay kits, immunohistochemistry techniques, array-based systems, bioassay kits, *in vivo* injection of an anticytokine immunoglobulin, multiplexed fluorescent microsphere immune-assays, homogeneous time-resolved fluorescence assays, bead-based techniques, interferometers, flow cytometry, etc.). Cytokine proteins may be measured directly or indirectly, such as by measuring mRNA transcripts.

[0152] The measurement of biomarker levels can utilize one or more capture or detection agents that specifically bind to the biomarker, such as a labeled antibody to bind and detect a biomarker. In some implementations, measurement of biomarkers may utilize a detection agent that has a functional interaction with the biomarker. In other implementations, measurement of biomarkers may be carried out using imaging/spectroscopy techniques that allow biomarkers levels to be assessed in a non-invasive manner or by tissue sampling. Capture or detection agents may be used. In some implementations, binding of a biomarker to a capture agent and/or interaction of the biomarker with a detection agent results in a quantitative, or detectable, signal. The signal may include, for example, a colorimetric, fluorescent, heat, energy, or electric signal. The detectable, quantitative signal may be transmitted to an external output or monitoring device. In some implementations, binding of a biomarker to a capture agent results in a signal that can be transmitted to an external monitoring device. For example, binding of a biomarker to a capture or detection agent may be detected using a high sensitivity fluorescence technique such as a resonance energy transfer method (e.g., Forster resonance energy transfer, bioluminescence resonance energy transfer, or surface plasmon resonance energy transfer).

[0153] In various implementations, the measurement of pre- and post-treatment biomarker levels may be carried out using the same device that is used to carry out the treatment (e.g., ablation, denervation) or a component attached to the treatment device. Alternatively, biomarker level or activity may be carried out using a separate device from the



treatment device. The separate biomarker assessment device may be inserted through the same introducer as the treatment device or a separate introducer.

[0154] Biomarkers may include genetic markers, products of gene expression, autoantibodies, cytokine/growth factors, proteins or enzymes (such as heat shock proteins), and/or acute phase reactants. Biomarkers may include compounds correlated to back pain, such as inflammatory cytokines, Interleukin-1-beta (IL-1-beta), interleukin-1-alpha (IL-1-alpha), interleukin-6 (IL-6), IL-8, IL-10, IL-12, tumor necrosis factor-alpha (TNF-alpha), granulocyte-macrophage colony stimulating factor (GM-CSF), interferon gamma (INF-gamma), and prostaglandin E2 (PGE2). Biomarkers may also be indicative of presence of tumor cells or tissue if tumor tissue is being targeted by the treatment. Biomarkers may be found in blood serum/plasma, urine, synovial fluid, tissue biopsy, foramina, intervertebral discs, cerebrospinal fluid, or cells from blood, fluid, lymph node, and/or tissue.

[0155] One or more samples, images, and/or measurements may be obtained from a patient prior to treatment and after treatment and the presence of one or more biomarkers in the pre-treatment and post-treatment samples may be compared to confirm treatment efficacy. The comparison may involve comparison of levels or activity of the biomarkers within the samples. For example, there may be a burst or spike in biomarker concentration following ablation of the basivertebral nerve trunk or branches thereof that can be detected or measured within a collected biological sample.

[0156] As another example, the change in the level or activity of the biomarker(s) may be an indirect response to ablation of the basivertebral nerve trunk or branches thereof (e.g., an inflammatory or anti-inflammatory protein, such as a cytokine protein, a heat shock protein, or a stress response protein that is triggered in response to ablative energy being applied to the target treatment region or a non-protein biomarker associated with nervous activity, such as catecholamines, neurotransmitters, norepinephrine levels, neuropeptide Y levels, epinephrine levels, and/or dopamine levels). The post-treatment samples may be obtained immediately following treatment (e.g., within seconds after treatment, within about 15 minutes following treatment, or within about 30 minutes following treatment) and/or may be obtained after a more significant amount of time following treatment (e.g., 24 hours after treatment, 3 days after treatment, 1 week after treatment, 2 weeks after treatment, 1 month after treatment, 3 months after treatment, 6 months after treatment).

[0157] Brain imaging or monitoring of brain activity (e.g., electroencephalography, magnetoencephalography) may also be used to confirm efficacy of treatment. The brain imaging or monitoring may be used to determine perception of pain by the patient. Such imaging and/or temperature and/or impedance measurements may also be used in combination with, or as an alternative to, biomarkers to assess lesion formation or confirmation of denervation. Various inputs (e.g., biomarker activity or levels, physiological parameter measurements indicative of neuronal activity, temperature measurements, impedance measurements, and/or images), may be combined (e.g., weighted combinations) to generate a quantitative pain score that can be used to confirm pain relief (as an adjunct or as an alternative to subjective pain relief confirmation). The pain score may be generated using an automated algorithm executed by a processor of a pain analyzer system. The pain analyzer system may receive input from various sensors, imaging devices, and/or the like and the input may be weighted and/or processed by one or more circuits or processing modules of the pain analyzer system to generate the quantitative pain score. The quantitative pain score may be output on a display (e.g., of a generator).

#### **ROBOTICALLY-ASSISTED ACCESS AND/OR TREATMENT**

[0158] Access to and/or treatment within or adjacent bones (e.g., vertebral bodies) may be facilitated by the use of robotic navigation systems or robotically-controlled devices (e.g., computer-aided or computer-assisted systems or devices). For example, robotics may be used to facilitate or assist in positioning, targeting, deployment (e.g., hammering) so as to avoid over-insertion that might cause injury or damage, and/or to facilitate nerve sensing. **FIGURE 7** schematically illustrates an example of a robotically-enabled system 700. The robotic system 700 may be a robotic control, surgical, and/or navigation system capable of performing a variety of medical and/or diagnostic procedures and/or providing guidance and enhanced imaging to a clinician. The robotic system 700 may be a robotic assisted spinal surgery system, or a spinal robotics system.

[0159] The robotic system 700 may include an operator workstation or control console 702 from which a clinician can control movement of one or more robotic arms 703 to provide improved ease of use and fine control of movement. The workstation or control console 702 may include a computer-based control system that stores and is configured to execute (e.g., using one or more processors) program instructions stored on a non-transitory

computer-readable storage medium (e.g., solid state storage drive, magnetic storage drive, other memory).

[0160] The robotic arms 703 may be configured to move with six or more degrees of freedom and to support or carry the access tools, treatment devices, and/or diagnostic devices. The robotic arms 703 may be coupled to a support system and controlled by one or more instrument drive systems that are in turn controlled by the control console 702. The instrument drive systems may include electro-mechanical components and mechanisms (e.g., gears, pulleys, joints, hydraulics, wires, etc.) configured to actuate and move the robotic arms 703.

[0161] The robotic system 700 may also include one or more imaging devices 704 (cameras, endoscopes, laparoscopes, ultrasound imaging modality, fluoroscopic imaging modality, MR imaging modality, and/or the like). The imaging devices 704 may be supported or carried by one or more of the robotic arms 703. The imaging devices 704 may be components of an imaging system that facilitates 360-degree scanning of a patient. The imaging devices 704 may include stereotactic cameras and/or electromagnetic field sensors. In some implementations, the imaging devices 704 of the robotic system 700 reduce an amount of patient exposure to radiation. The imaging devices 704 may be calibrated to patient anatomy or using reference pins or trackers positioned at one or more locations of the patient's body by a registration, or localization, system. The registration system may include multiple computing devices (e.g., processors and computer-readable memory for storing instructions to be executed by the processor(s)). The registration may involve identification of natural landmarks of one or more vertebrae (e.g., using a pointer device or the registration system).

[0162] The imaging system may be configured to communicate with software (e.g., running on the operator workstation or control console 702 or the registration system) that is configured to generate a real-time 3D map that may be registered with the robotic arms 703 or instruments carried by the robotic arms 703. The software may include surgery planning software configured to plan, based on pre-operative images (e.g., obtained via CT, MRI, fluoroscopy, or other imaging modalities) a desired trajectory for access to a target treatment location within a vertebral body or other bone. However, pre-operative planning may not be used in some implementations and navigation may be performed intraoperatively.

The software may include navigation software configured to control the robotic arms 703 and provide feedback regarding navigation (e.g., trajectory and positioning information) to an operator at the operator workstation or on a separate display device. A computing device of the control console 702 is configured to direct movement of the robotic arms 703 based on instructions executed by the computing device (either via inputs (e.g., joystick controls) from a clinician or via automated programs and artificial intelligence algorithms stored in memory). The computing device includes one or more specialized processors. The robotic system 700 may be used to carry out any of the methods of access, diagnosis, or treatment described herein while providing controlled movements to reduce likelihood of injury caused by manual operator error or error in judgment.

[0163] In some implementations, the robotic system 700 includes a closed-loop system that alters trajectory of access tools or treatment devices based on feedback (e.g., artificial intelligence). The neuromodulation may also be robotically implemented based on intelligent (e.g., artificial intelligence) feedback. The robotic system 700 may include a machine-driven navigation system deploying an energy source towards a target within a vertebral body to be treated. Detection and monitoring of the energy source's proximity to the target may be provided by the one or more imaging devices. The robotic system 700 can independently modify the trajectory in response to imaging or other registration modalities. Modification of the trajectory may be via change in the configuration of a driving system (e.g., robotic arms 703) and/or by change of the configuration of the energy delivery device or assembly. Modification of trajectory may be automatic (e.g., closed-loop) or based on a feedback mechanism to an operator (e.g., open-loop). The open-loop mode may include boundary conditions (e.g., haptic conditions) or not. The detection and monitoring functions may rely on pre-operative and/or intra-operative data. Registration and targeting may be *a priori* or interactive.

## **CONCLUSION**

[0164] In some implementations, the system comprises various features that are present as single features (as opposed to multiple features). For example, in one embodiment, the system includes a single radiofrequency generator, a single introducer cannula with a single stylet, a single radiofrequency energy delivery device or probe, and a single bipolar pair of electrodes. A single thermocouple (or other means for measuring

temperature) may also be included. Multiple features or components are provided in alternate embodiments.

[0165] In some implementations, the system comprises one or more of the following: means for tissue modulation (e.g., an ablation or other type of modulation catheter or delivery device), means for monitoring temperature (e.g., thermocouple, thermistor, infrared sensor), means for imaging (e.g., MRI, CT, fluoroscopy), means for accessing (e.g., introducer assembly, curved cannulas, drills, curettes), etc.

[0166] Although certain embodiments and examples have been described herein, aspects of the methods and devices shown and described in the present disclosure may be differently combined and/or modified to form still further embodiments. Additionally, the methods described herein may be practiced using any device suitable for performing the recited steps. Further, the disclosure (including the figures) herein of any particular feature, aspect, method, property, characteristic, quality, attribute, element, or the like in connection with various embodiments can be used in all other embodiments set forth herein. The section headings used herein are merely provided to enhance readability and are not intended to limit the scope of the embodiments disclosed in a particular section to the features or elements disclosed in that section.

[0167] While the embodiments are susceptible to various modifications, and alternative forms, specific examples thereof have been shown in the drawings and are herein described in detail. It should be understood, however, that the embodiments are not to be limited to the particular forms or methods disclosed, but to the contrary, the embodiments are to cover all modifications, equivalents, and alternatives falling within the spirit and scope of the various embodiments described and the appended claims. Any methods disclosed herein need not be performed in the order recited. The methods disclosed herein include certain actions taken by a practitioner; however, they can also include any third-party instruction of those actions, either expressly or by implication. For example, actions such as “applying thermal energy” include “instructing the applying of thermal energy.”

[0168] The terms “top,” “bottom,” “first,” “second,” “upper,” “lower,” “height,” “width,” “length,” “end,” “side,” “horizontal,” “vertical,” and similar terms may be used herein; it should be understood that these terms have reference only to the structures shown in the figures and are utilized only to facilitate describing embodiments of the disclosure.

The terms “proximal” and “distal” are opposite directional terms. For example, the distal end of a device or component is the end of the component that is furthest from the operator during ordinary use. A distal end or tip does not necessarily mean an extreme distal terminus. The proximal end refers to the opposite end, or the end nearest the operator during ordinary use. Various embodiments of the disclosure have been presented in a range format. It should be understood that the description in range format is merely for convenience and brevity and should not be construed as an inflexible limitation on the scope of the invention. The ranges disclosed herein encompass any and all overlap, sub-ranges, and combinations thereof, as well as individual numerical values within that range. For example, description of a range such as from 70 to 115 degrees should be considered to have specifically disclosed subranges such as from 70 to 80 degrees, from 70 to 100 degrees, from 70 to 110 degrees, from 80 to 100 degrees etc., as well as individual numbers within that range, for example, 70, 80, 90, 95, 100, 70.5, 90.5 and any whole and partial increments therebetween. Language such as “up to,” “at least,” “greater than,” “less than,” “between,” and the like includes the number recited. Numbers preceded by a term such as “about” or “approximately” include the recited numbers. For example, “about 2:1” includes “2:1.” For example, the terms “approximately”, “about”, and “substantially” as used herein represent an amount close to the stated amount that still performs a desired function or achieves a desired result.

## WHAT IS CLAIMED IS:

1. A method of detecting and treating back pain of a subject, the method comprising:
  - obtaining images of a vertebral body of the subject;
  - analyzing the images to determine whether the vertebral body exhibits one or more symptoms associated with a pre-Modic change; and
  - ablating a basivertebral nerve within the vertebral body if it is determined that the vertebral body exhibits one or more symptoms associated with a pre-Modic change.
2. The method of Claim 1:
  - wherein ablating the basivertebral nerve within the vertebral body comprises advancing at least a distal end portion of a bipolar radiofrequency energy delivery probe comprising two electrodes to a target treatment location within the vertebral body and applying radiofrequency energy to the location to generate a thermal treatment dose sufficient to ablate the basivertebral nerve,
  - wherein the radiofrequency energy has a frequency between 400 kHz and 600 kHz,
  - wherein the thermal treatment dose is configured to achieve a target temperature of between 75 degrees Celsius and 90 degrees Celsius at the location,
  - wherein the thermal treatment dose is delivered with a temperature ramp of between 0.1 and 5 degrees Celsius per second,
  - wherein the radiofrequency energy is applied for an active energy delivery time of between 5 minutes and 10 minutes, and
  - wherein the thermal treatment dose forms a targeted lesion zone at the target treatment location having a maximum cross-sectional dimension of less than 15 mm.
3. The method of Claim 1, wherein ablating the basivertebral nerve within the vertebral body comprises applying a thermal treatment dose to a location within the vertebral body of at least 240 cumulative equivalent minutes ("CEM") using a CEM at 43 degrees Celsius model.
4. The method of Claim 1, wherein the images are obtained using an MRI imaging modality.

5. The method of any one of Claims 1-3, wherein the images are obtained using a CT imaging modality.

6. The method of any one of Claims 1-4, wherein the one or more symptoms comprise characteristics likely to result in Modic changes.

7. The method of Claim 6, wherein the one or more symptoms comprise characteristics likely to result in Type 1 Modic changes.

8. The method of Claim 6, wherein the one or more symptoms comprise characteristics likely to result in Type 2 Modic changes.

9. The method of any one of Claims 1-4, wherein the one or more symptoms comprise initial indications or precursors of edema or inflammation at a vertebral endplate prior to a formal characterization or diagnosis as a Modic change.

10. The method of any one of Claims 1-4, wherein the one or more symptoms are selected from the group consisting of: edema, inflammation, and tissue change within the vertebral body or along a portion of a vertebral endplate of the vertebral body.

11. The method of any one of Claims 1-4, wherein the one or more symptoms include tissue changes.

12. The method of Claim 11, wherein the tissue changes comprise tissue lesions or changes in tissue type or characteristics of an endplate of the vertebral body.

13. The method of Claim 11, wherein the tissue changes comprise tissue lesions or changes in tissue type or characteristics of bone marrow of the vertebral body.

14. The method of Claim 3, wherein applying the thermal treatment dose comprises delivery of radiofrequency energy.

15. The method of Claim 3, wherein applying a thermal treatment dose comprises delivery of ultrasound energy.

16. The method of Claim 3, wherein applying a thermal treatment dose comprises delivery of microwave energy.

17. The method of Claim 3, wherein applying a thermal treatment dose comprises delivery of laser energy.



18. The method of any one of Claims 1-4, further comprising ablating a basivertebral nerve within a second vertebral body superior to or inferior to the vertebral body recited in Claim 1.

19. The method of any one of Claims 1-4, wherein the one or more symptoms are selected from the group consisting of: focal defects, erosive defects, rim defects, and corner defects.

20. The method of any one of Claims 1-4, wherein ablating the basivertebral nerve comprises generating a targeted ablation zone formed by a lesion having a “football” or elliptical profile shape.

21. The method of any one of Claims 1-4, wherein ablating the basivertebral nerve comprises generating a targeted ablation zone having a maximum cross-sectional dimension of less than 15 mm.

22. The method of any one of Claims 1-4, wherein ablating the basivertebral nerve comprises generating a targeted ablation zone having a major diameter along a long axis of between 20 mm and 30 mm and a minor diameter along a short axis of between 5 mm and 15 mm.

23. The method of any one of Claims 1-4, wherein the method is performed without use of any cooling fluid.

24. A method of detecting and treating back pain of a subject, the method comprising:  
identifying a candidate vertebral body for treatment based on a determination that the vertebral body exhibits one or more symptoms or defects associated with vertebral endplate degeneration,

wherein the one or more symptoms associated with vertebral endplate degeneration or defects comprise pre-Modic change characteristics; and

ablating a basivertebral nerve within the identified candidate vertebral body by applying a thermal treatment dose to a location within the vertebral body of at least 240 cumulative equivalent minutes (“CEM”) using a CEM at 43 degrees Celsius model.

25. The method of Claim 24, wherein the determination is based on images of the candidate vertebral body.

26. The method of Claim 25, wherein the images comprise MRI images.

27. The method of Claim 24, wherein the determination is based on obtaining biomarkers from the subject.

28. The method of Claim 27, wherein the biomarkers are obtained from one or more blood serum samples.

29. The method of Claim 27 or 28, wherein the biomarkers are obtained over an extended period of time.

30. The method of any one of Claims 24-28, wherein the location within the vertebral body is in a posterior half of the vertebral body.

31. The method of any one of Claims 24-28, wherein the location within the vertebral body includes a geometric center of the vertebral body.

32. The method of any one of Claims 24-28, wherein the location is at least 5 mm from a posterior border of the vertebral body.

33. The method of any one of Claims 24-28, wherein the location is at least 1 cm from a posterior border of the vertebral body.

34. The method of any one of Claims 24-28, further comprising advancing at least a distal end portion of a bipolar radiofrequency energy delivery probe comprising two electrodes to the location.

35. The method of Claim 34, further comprises:

forming a passageway through a pedicle and into the vertebral body;

then advancing at least the distal end portion of the bipolar radiofrequency energy delivery probe along the passageway to the location; and

applying the thermal treatment dose to the location using the bipolar radiofrequency energy delivery probe.

36. The method of 35, further comprising applying radiofrequency energy to a second location within a second vertebral body.

37. The method of Claim 36, wherein the second vertebral body is of a vertebra of a different vertebral level than the vertebral body recited in Claim 35.

38. The method of Claim 36, wherein the second vertebral body is of a vertebra adjacent to the vertebral body recited in Claim 35.

39. An introducer system adapted to facilitate percutaneous access to a target treatment location within bone, the introducer system comprising:

an introducer cannula comprising a proximal handle and a distal elongate hypotube extending from the proximal handle; and

an introducer stylet comprising a proximal handle and a distal elongate shaft extending from the proximal handle,

wherein the proximal handle of the introducer cannula comprises a central opening in its upper surface that is coupled to a lumen of the distal elongate hypotube to facilitate insertion of the introducer stylet into the central opening and into the distal elongate hypotube,

wherein the proximal handle of the introducer cannula comprises one or more slots configured to receive at least a portion of the proximal handle of the introducer stylet so as to facilitate engagement and alignment between the introducer stylet and the introducer cannula,

wherein the proximal handle of the introducer stylet comprises an anti-rotation tab configured to be received within one of the one or more slots so as to prevent rotation of the introducer stylet within the introducer cannula, and

wherein a distal end of the distal elongate shaft of the introducer stylet comprises a distal cutting tip and a scalloped section proximal to the distal cutting tip so as to provide gaps between an outer diameter of the distal end of the distal elongate shaft and the inner diameter of the introducer cannula.

40. The introducer system of Claim 39, wherein the proximal handle of the introducer stylet further comprises a press button that, when pressed: (a) disengages the anti-rotation tab and allows for rotation of the introducer stylet within the introducer stylet, and (b) allows for removal of the introducer stylet from the introducer cannula.

41. The introducer system of Claim 39, wherein the proximal handle of the introducer stylet comprises a ramp configured to provide a mechanical assist for removal of the introducer stylet from the introducer cannula.

42. The introducer system of Claim 39, wherein the proximal handle of the introducer cannula comprises a T-shaped design.

43. The introducer system of any one of Claims 39-42, further comprising a curved cannula assembly, the curved cannula assembly comprising:

a cannula comprising a proximal handle with a curved insertion slot and a distal polymeric tube,

wherein the distal polymeric tube comprises a curved distal end portion having a preformed curvature but configured to bend when placed under constraint;

a stylet comprising a proximal handle and a distal elongate shaft,

wherein the distal elongate shaft comprises a curved distal end portion having a preformed curvature but configured to bend when placed under constraint and a distal channeling tip, and

wherein a length of the curved distal end portion of the distal elongate shaft proximal to the distal channeling tip comprises a cross-section circumference profile that is less than a full cross-section circumference profile such that there is a larger gap between an outer cross-sectional dimension of the curved distal end portion of the distal elongate shaft and the inner diameter of the curved distal end portion of the cannula along the length.

44. The introducer system of Claim 43, wherein the proximal handle of the stylet comprises a bail actuator that is adapted to cause axial movement of the distal channeling tip of the distal elongate shaft of the stylet with respect to the cannula so as to facilitate insertion of the curved cannula assembly through the introducer cannula and withdrawal of the stylet of the curved cannula assembly from the cannula of the curved cannula assembly after formation of a curved path within the bone.

45. The introducer system of any one of Claims 39-42, further comprising an introducer drill adapted to be introduced into and through the introducer cannula to form a further path within the bone after removal of the introducer stylet from the introducer cannula, the introducer drill comprising a fluted distal portion and a distal drill tip, wherein drill flutes of the fluted distal portion taper away from the distal drill tip so as to facilitate improved bone chip packing within an open volume defined by the drill flutes as bone chips are generated by operation of the introducer drill.

46. A system configured to provide curved access within bone, the system comprising:

a cannula comprising a proximal handle with a curved insertion slot and a distal polymeric tube,

wherein the distal polymeric tube comprises a curved distal end portion having a preformed curvature but configured to bend when placed under constraint;

a stylet comprising a proximal handle and a distal elongate shaft,

wherein the distal elongate shaft comprises a curved distal end portion having a preformed curvature but configured to bend when placed under constraint and a distal channeling tip, and

wherein a length of the curved distal end portion of the distal elongate shaft proximal to the distal channeling tip comprises a cross-section circumference profile that is less than a full cross-section circumference profile such that there is a larger gap between an outer cross-sectional dimension of the curved distal end portion of the distal elongate shaft and the inner diameter of the curved distal end portion of the cannula along the length.

47. The system of Claim 46, wherein the cross-section circumference profile comprises a “D” shape.

48. The system of Claim 46, wherein an upper surface of the length of the curved distal end portion is generally flat.

49. The system of Claim 46, wherein the proximal handle of the stylet comprises a bail configured to be actuated so as to cause proximal axial retraction of the stylet with respect to the cannula when the proximal handle of the stylet is engaged with the proximal handle of the cannula.

50. The system of Claim 46, wherein the curved distal end portion of the distal elongate shaft is constructed such that the preformed curvature of the curved distal end portion does not deviate by more than 20 degrees upon insertion within the bone.

51. The system of any one of Claims 46-50, wherein a maximum vertical cross-sectional dimension of the length of the curved distal end portion is between 50% and 70% of a maximum cross sectional dimension of proximal and distal regions of the curved distal end portion bordering the length.

52. The system of Claim 46:

wherein the cross-section circumference profile comprises a “D” shape,

wherein an upper surface of the length of the curved distal end portion is generally flat,

wherein the proximal handle of the stylet comprises a bail configured to be actuated so as to cause proximal axial retraction of the stylet with respect to the cannula when the proximal handle of the stylet is engaged with the proximal handle of the cannula, and/or

wherein the curved distal end portion of the distal elongate shaft is constructed such that the preformed curvature of the curved distal end portion does not deviate by more than 20 degrees upon insertion within the bone.

53. A method of accessing a target treatment location within a vertebral body identified as having hard bone, the method comprising:

advancing an introducer assembly through skin adjacent the vertebral body and into a pedicle connected to the vertebral body, the introducer assembly comprising an introducer stylet inserted within an introducer cannula with a distal cutting tip of the introducer stylet extending out of the introducer cannula;

removing the introducer stylet from the introducer cannula while leaving the introducer cannula in place;

inserting an introducer drill through and beyond the introducer cannula and through the pedicle and into cancellous bone of the vertebral body,

wherein inserting the introducer drill comprises rotating the introducer drill,

wherein the introducer drill comprises a fluted distal portion and a distal drill tip, and

wherein drill flutes of the fluted distal portion taper away from the distal drill tip so as to facilitate improved bone chip packing within an open volume defined by the drill flutes as bone chips are generated by operation of the introducer drill.

54. The method of Claim 53, further comprising removing the introducer drill from the introducer cannula.

55. The method of Claim 54, further comprising inserting a curved cannula assembly into a curved slot of a proximal handle of the introducer cannula, wherein the curved cannula assembly comprises:

a second cannula comprising a proximal handle with a curved insertion slot and a distal polymeric tube,

wherein the distal polymeric tube comprises a curved distal end portion having a preformed curvature but configured to bend when placed under constraint;

a second stylet comprising a proximal handle and a distal elongate shaft,

wherein the distal elongate shaft comprises a curved distal end portion having a preformed curvature but configured to bend when placed under constraint and a distal channeling tip,

wherein a length of the curved distal end portion of the distal elongate shaft proximal to the distal channeling tip comprises a cross-section circumference profile that is less than a full cross-section circumference profile such that there is a larger gap between an outer cross-sectional dimension of the curved distal end portion of the distal elongate shaft and the inner diameter of the curved distal end portion of the second cannula along the length.

56. The method of Claim 55, further comprising removing the second stylet from the second cannula.

57. The method of Claim 56, further comprising inserting a third stylet into a slot of the proximal handle of the second cannula and beyond an open distal tip of the second cannula, wherein the third stylet is configured to form a straight path starting from the open distal tip of the second cannula toward the target treatment location, and removing the third stylet from the second cannula after formation of the straight path.

58. The method of Claim 56 or 57, further comprising inserting a treatment device into the slot of the proximal handle of the second cannula and beyond the open distal tip of the second cannula to the target treatment location and performing therapy at the target treatment location using the treatment device.

59. The method of Claim 58, wherein the therapy comprises ablating at least 75% of the branches of a basivertebral nerve within the bone.

60. A method of ablating a basivertebral nerve within a vertebral body of a subject and confirming efficacy of ablation of the basivertebral nerve, the method comprising:

obtaining a baseline reading of a level of a biomarker from the subject;

performing a denervation procedure on the subject,

wherein the denervation procedure comprises denervating the basivertebral nerve within the vertebral body;

obtaining a post-procedure reading of the level of the biomarker from the subject; and

determining an effect of the denervation procedure by comparing the post-procedure reading to the baseline reading.

61. The method of Claim 60, wherein the baseline reading and the post-procedure reading are obtained from cerebrospinal fluid adjacent the vertebral body of the subject.

62. The method of Claim 60, wherein the baseline reading and the post-procedure reading are obtained from a blood draw from the subject.

63. The method of Claim 62, wherein the blood draw is obtained from a location within or adjacent the vertebral body.

64. The method of any one of Claims 60 to 63, wherein denervating the basivertebral nerve within the vertebral body comprises applying radiofrequency energy to a target treatment region within the vertebral body sufficient to ablate the basivertebral nerve using a radiofrequency energy delivery device.

65. The method of any one of Claims 60 to 63, wherein denervating the basivertebral nerve within the vertebral body comprises applying ultrasound energy to a target treatment region within the vertebral body sufficient to ablate the basivertebral nerve using an ultrasound energy delivery device.

66. The method of any one of Claims 60 to 63, wherein denervating the basivertebral nerve within the vertebral body comprises applying microwave energy to a target treatment region within the vertebral body sufficient to ablate the basivertebral nerve using a microwave energy delivery device.

67. The method of any one of Claims 60 to 63, wherein denervating the basivertebral nerve within the vertebral body comprises applying an ablative fluid to a target treatment region within the vertebral body.

68. The method of any of Claim 67, wherein the ablative fluid comprises one of: steam, a chemical adapted to denervate the nerve, or a cryoablative fluid.

69. The method of any one of Claims 60 to 63, wherein denervating the basivertebral nerve within the vertebral body comprises delivering a water jet at a pressure sufficient to denervate the nerve.

70. A method of treating a vertebral body, the method comprising:



inserting a first access assembly into a first target location of the vertebral body, the first access assembly comprising a first cannula and a first stylet;

removing the first stylet from the first cannula;

inserting a second access assembly into a second target location of the vertebral body, the second access assembly comprising a second cannula and a second stylet;

removing the second stylet;

inserting a first radiofrequency energy delivery device through the first cannula, the first radiofrequency energy delivery device comprising at least two electrodes;

inserting a second radiofrequency energy delivery device through the second cannula, the second radiofrequency energy delivery device comprising at least two electrodes;

positioning the at least two electrodes of the first radiofrequency energy delivery device within the vertebral body;

positioning the at least two electrodes of the second radiofrequency energy delivery device within the vertebral body; and

applying power to the first and second radiofrequency energy delivery devices sufficient to create a lesion within the vertebral body having a shape selected from one of the following: football shape, cigar shape, X shape, cross shape, or UFO shape.

71. The method of Claim 70, wherein the lesion is sufficient to ablate a basivertebral nerve within the vertebral body.

72. The method of Claim 70, wherein the lesion has a maximum width of 10 mm and a maximum length of 30 mm.

73. The method of any one of Claims 70-72, wherein the first radiofrequency energy delivery device and the second radiofrequency energy delivery device each comprise a bipolar device having an active electrode and a return electrode.

74. The method of Claim 73, wherein the step of applying power to the first and second radiofrequency energy delivery devices comprises independently applying power to the first and second radiofrequency energy delivery devices for a first duration of time.

75. The method of Claim 74, wherein the step of applying power to the first and second radiofrequency energy delivery devices further comprises applying a voltage differential between at least one of the at least two electrodes of the first radiofrequency energy delivery device and at least one of the at least two electrodes of the second radiofrequency energy delivery device for a second duration of time.

76. The method of any of Claims 70-72, wherein the step of applying power to the first and second radiofrequency energy delivery devices further comprises applying a voltage differential between at least one of the at least two electrodes of the first radiofrequency energy delivery device and at least one of the at least two electrodes of the second radiofrequency energy delivery device.

77. A method of ablating a basivertebral nerve within a vertebral body, the method comprising:

inserting an access assembly within a vertebral body using a robotically-controlled system, the access assembly including a cannula;

inserting a radiofrequency energy delivery device through the cannula to a target treatment site within the vertebral body using a robotically-controlled system; and

applying power to the target treatment site using the radiofrequency energy delivery device sufficient to ablate the basivertebral nerve.

78. The method of Claim 77, wherein the robotically-controlled system comprises one or more robotic arms.

79. The method of Claim 77, wherein the robotically-controlled system comprise an operator control console comprising at least one processor.

80. The method of any one of Claims 77 to 79, wherein the system comprises one or more imaging devices configured to provide feedback to the robotically-controlled system to control insertion of the access assembly and/or the radiofrequency energy delivery device.

81. A system for facilitating nerve ablation comprising:

an operator control console comprising a computer-based control system including at least one processor that is configured to execute program instructions stored on a non-transitory computer-readable medium to carry out a nerve ablation

procedure to ablate a basivertebral nerve within one or more vertebral bodies using automated robotic surgical arms;

one or more robotic surgical arms configured to move with six or more degrees of freedom and to support or carry access tools, treatment devices, and/or diagnostic devices; and

one or more imaging devices configured to obtain images of a target treatment site.

82. A radiofrequency (“RF”) generator for facilitating nerve ablation comprising:

a display screen;

an instrument connection port;

a first indicator light ring surrounding the instrument connection port that is configured to illuminate when a treatment device is connected to the instrument connection port,

wherein the first indicator light ring is configured to continuously illuminate in a solid color when the treatment device is connected to the instrument connection port, to flash at a first pulsing rate to prompt a clinician to connect the treatment device to the instrument connection port, and to flash at a second pulsing rate different than the first pulsing rate to indicate an error condition;

an energy delivery actuation button configured to be pressed by an operator to start and stop delivery of radiofrequency energy; and

a second indicator light ring surrounding the actuation button,

wherein the second indicator light ring is configured to continuously illuminate in a solid color when the generator is powered on and ready to initiate energy delivery, to flash at a third pulsing rate to prompt the operator to press the actuation button to initiate energy delivery, and to flash at a fourth pulsing rate different than the third pulsing rate when energy delivery has been paused or stopped.

83. The generator of Claim 82, wherein the first and second indicator light rings comprise circular LED light rings.

84. The generator of Claim 82 or 83, wherein the second pulsing rate is faster than the first pulsing rate.

85. The generator of any of Claims 82-84, wherein the fourth pulsing rate is faster than the third pulsing rate.

86. The generator of any of Claims 82-85, wherein the second pulsing rate is the same as the fourth pulsing rate, and wherein the first pulsing rate is the same as the third pulsing rate.

87. A kit for facilitating nerve ablation, comprising:

one or more biological assays,

wherein said one or more biological assays are configured to determine at least one biological marker,

wherein said determination comprises at least one of:

binary detection of a presence of said at least one biological marker,

and/or

a quantification of said at least one biological marker;

optionally, an access tool configured to access a target nerve to be treated;

optionally, a treatment tool configured to modulate the target nerve,

wherein the treatment tool is selected from the group consisting of one or a combination of the following:

a radiofrequency energy delivery device;

a microwave energy delivery device;

an ultrasound energy delivery device;

a cryomodulation device; and

a drug eluting device.

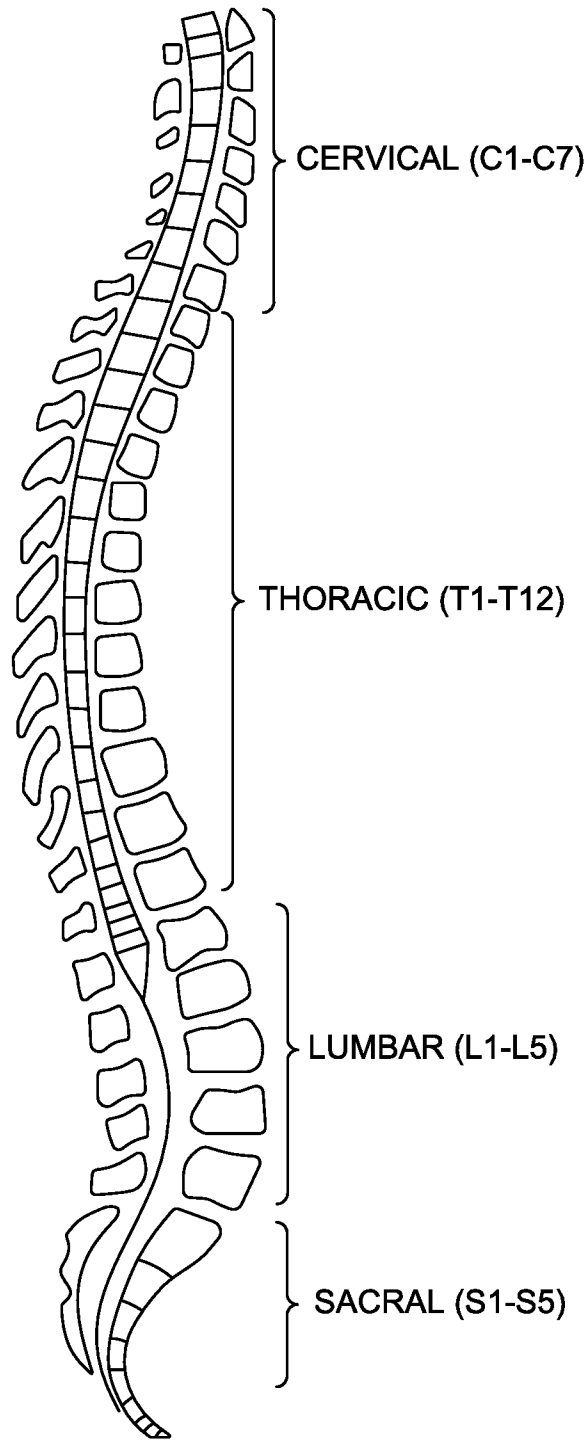

FIGURE 1

2/24

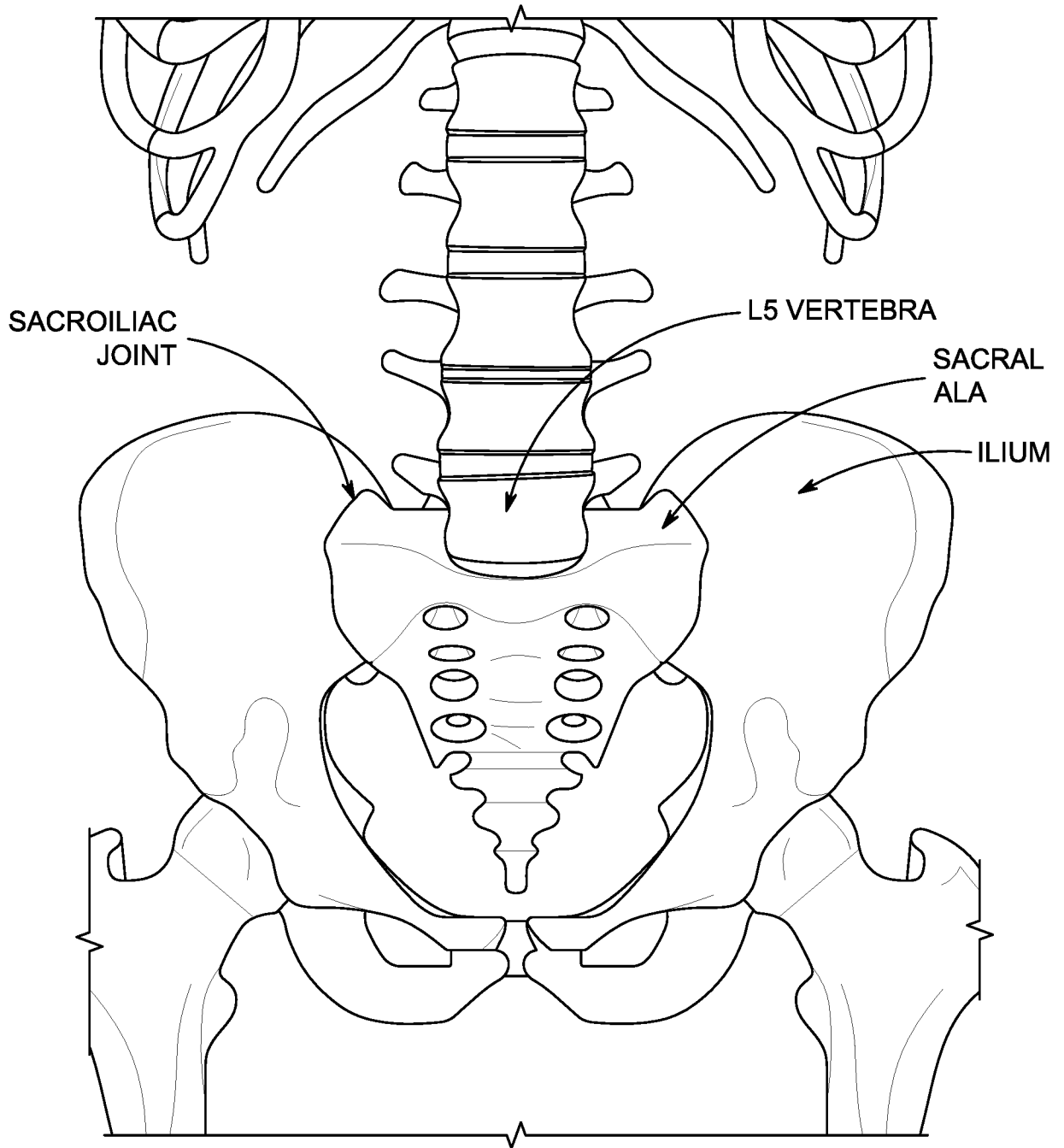

FIGURE 2

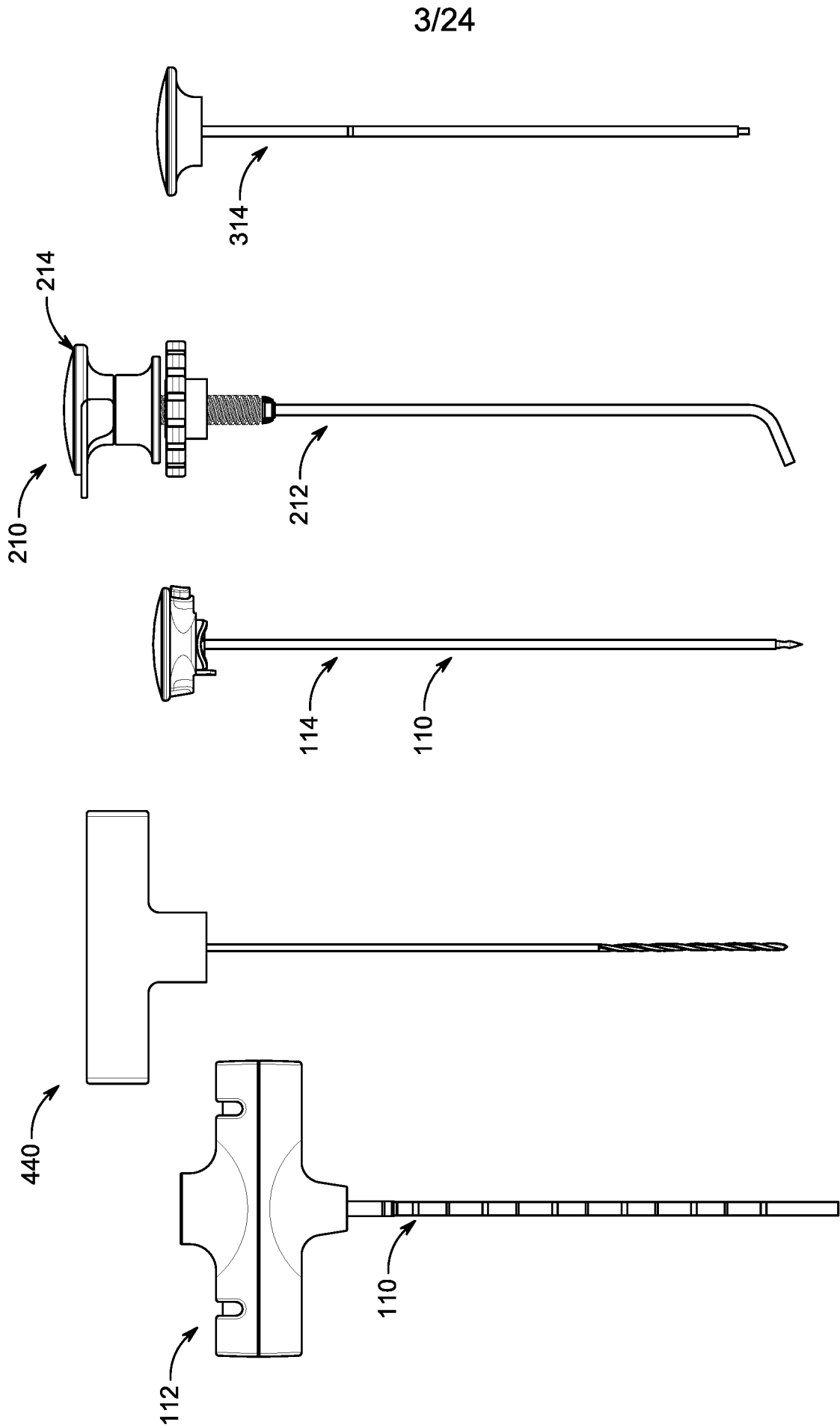

FIG. 3

4/24

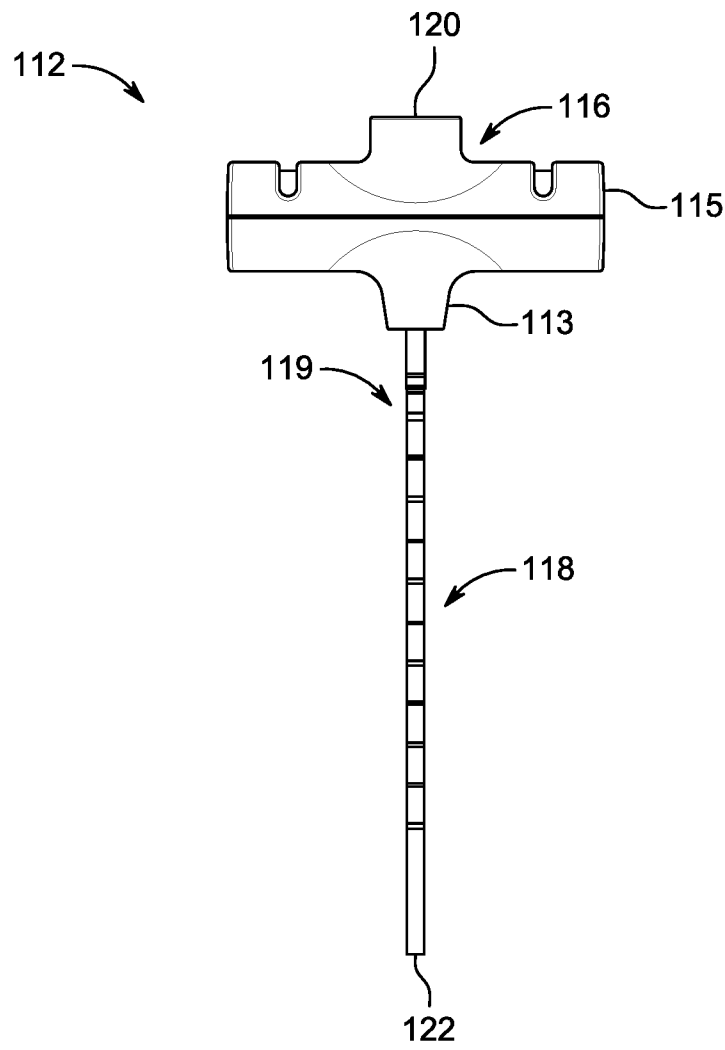

FIG. 3A

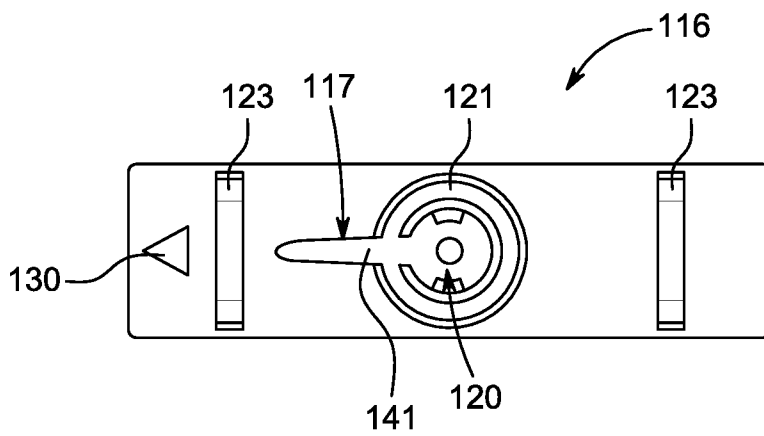

FIG. 3B



5/24

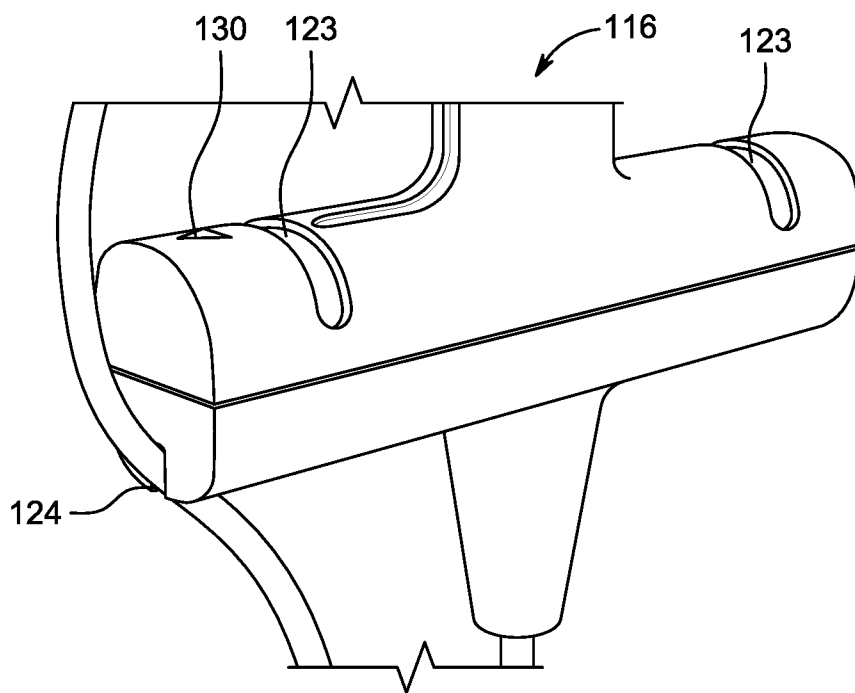

FIG. 3C

6/24

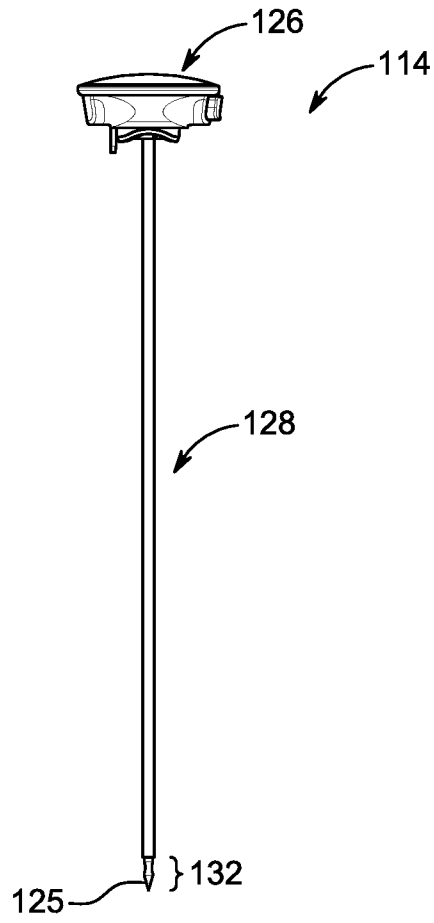

FIG. 3D

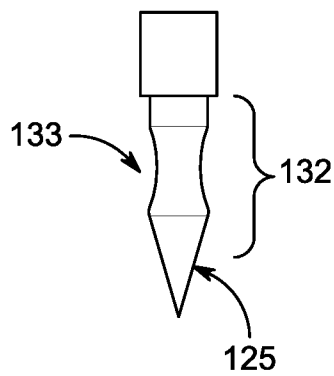

FIG. 3E

7/24

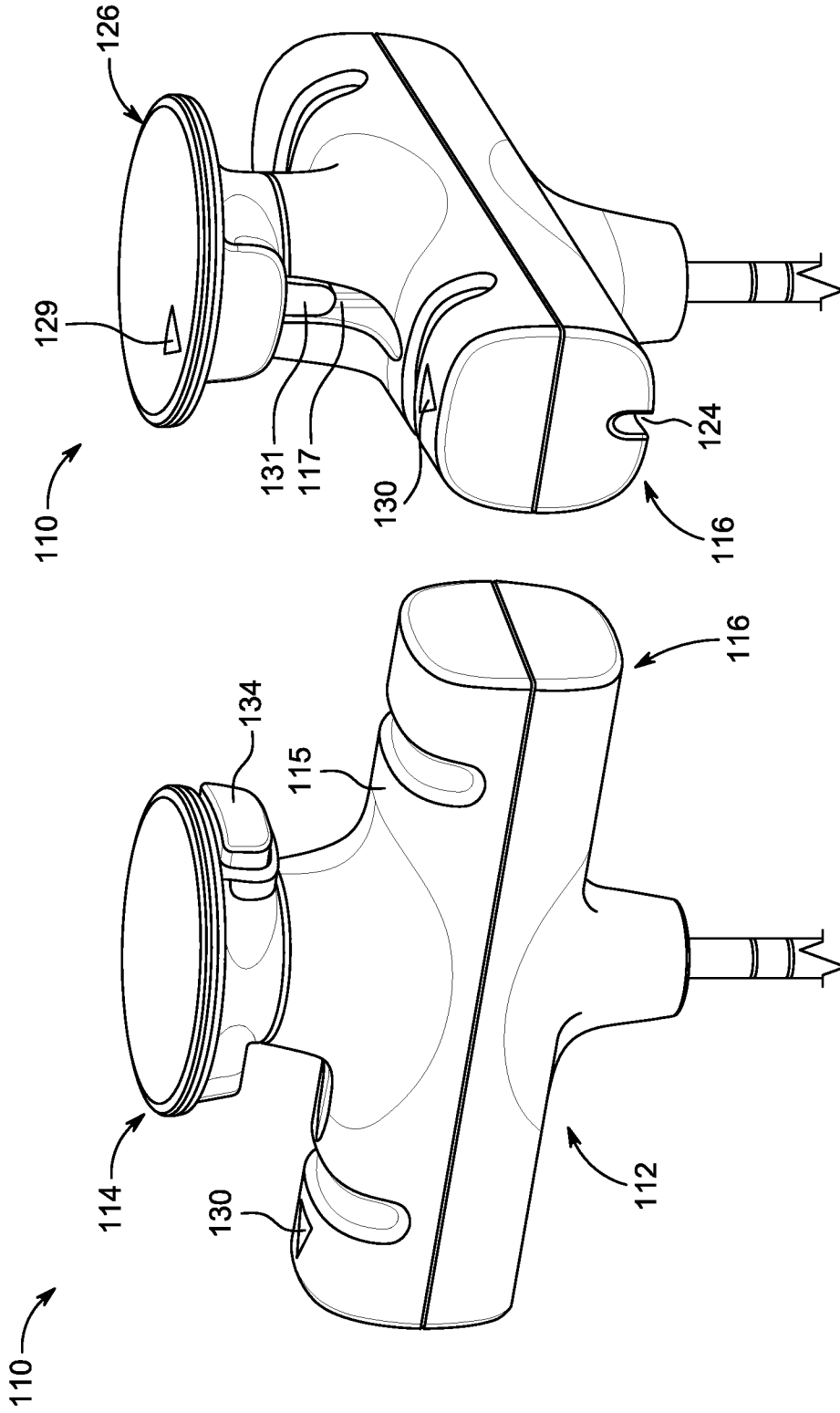

FIG. 3G

FIG. 3F

8/24

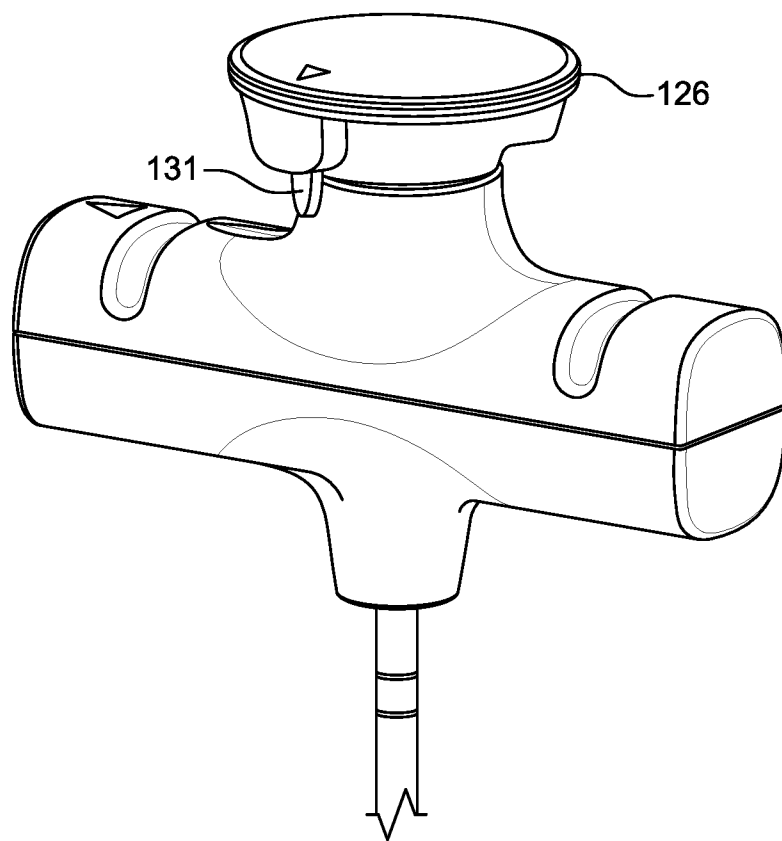

FIG. 3H

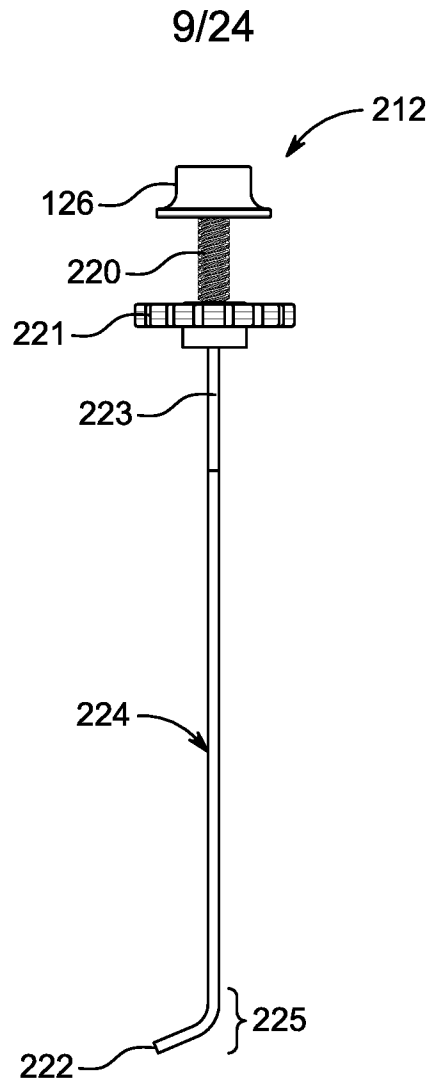

FIG. 3I

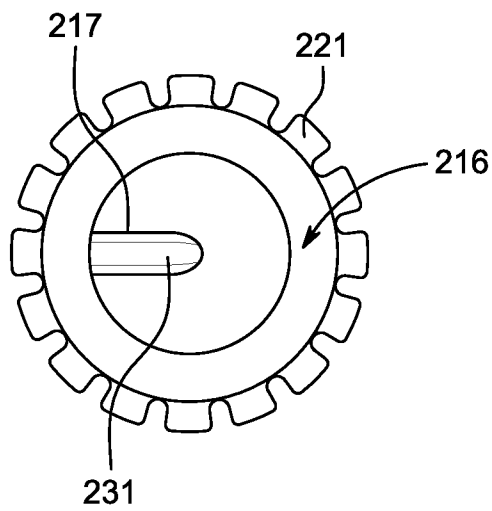

FIG. 3J

10/24

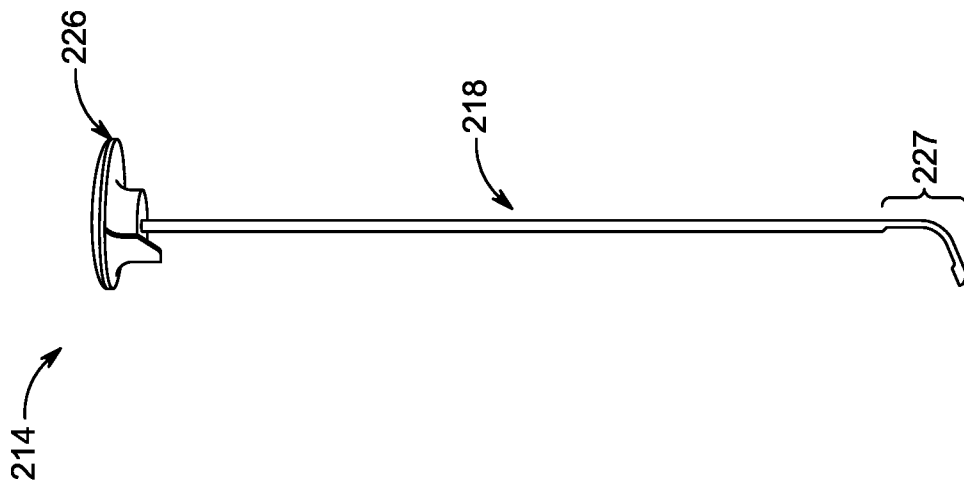

FIG. 3K

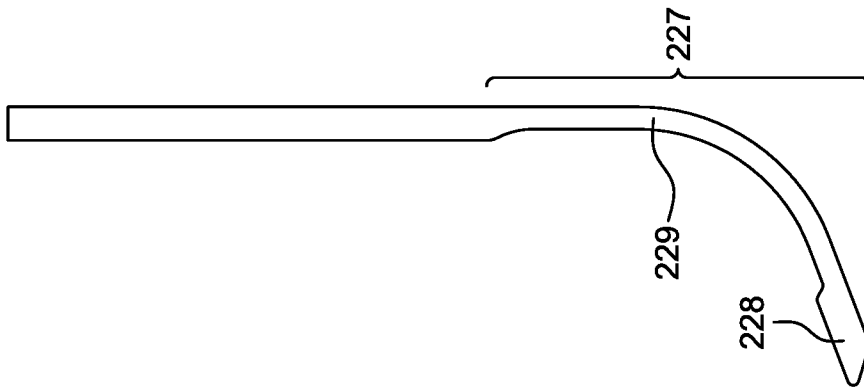

FIG. 3L

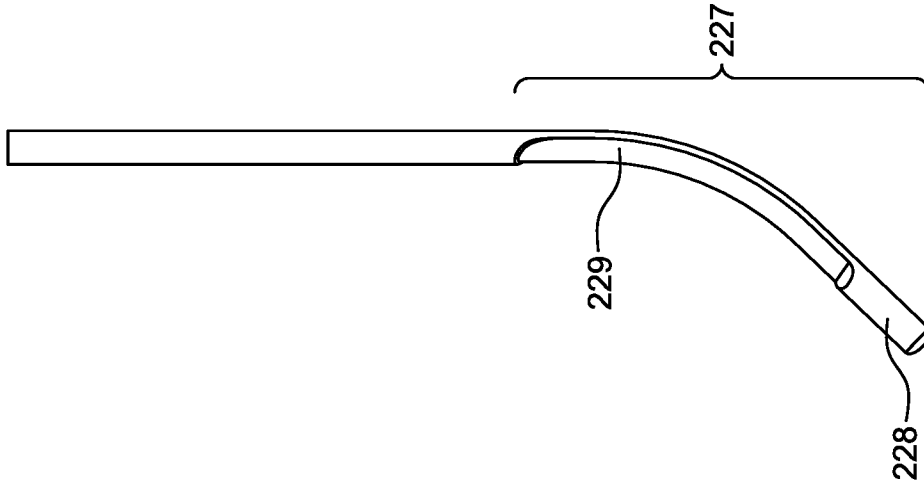

FIG. 3M

11/24

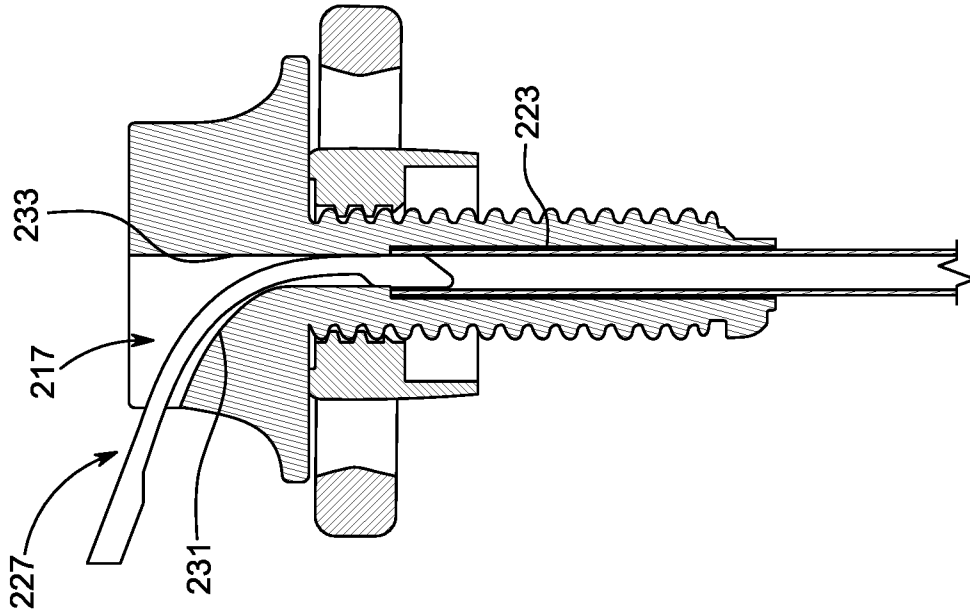

FIG. 30

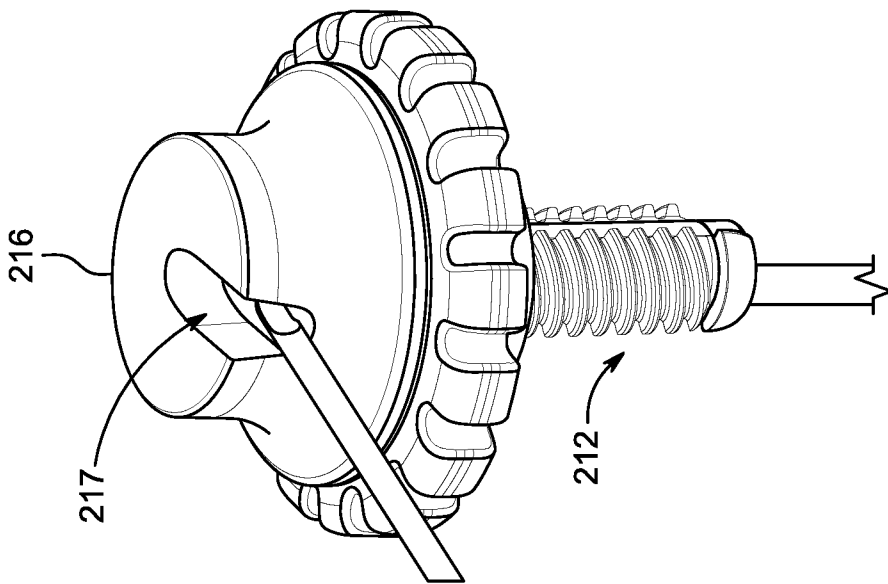

FIG. 3N

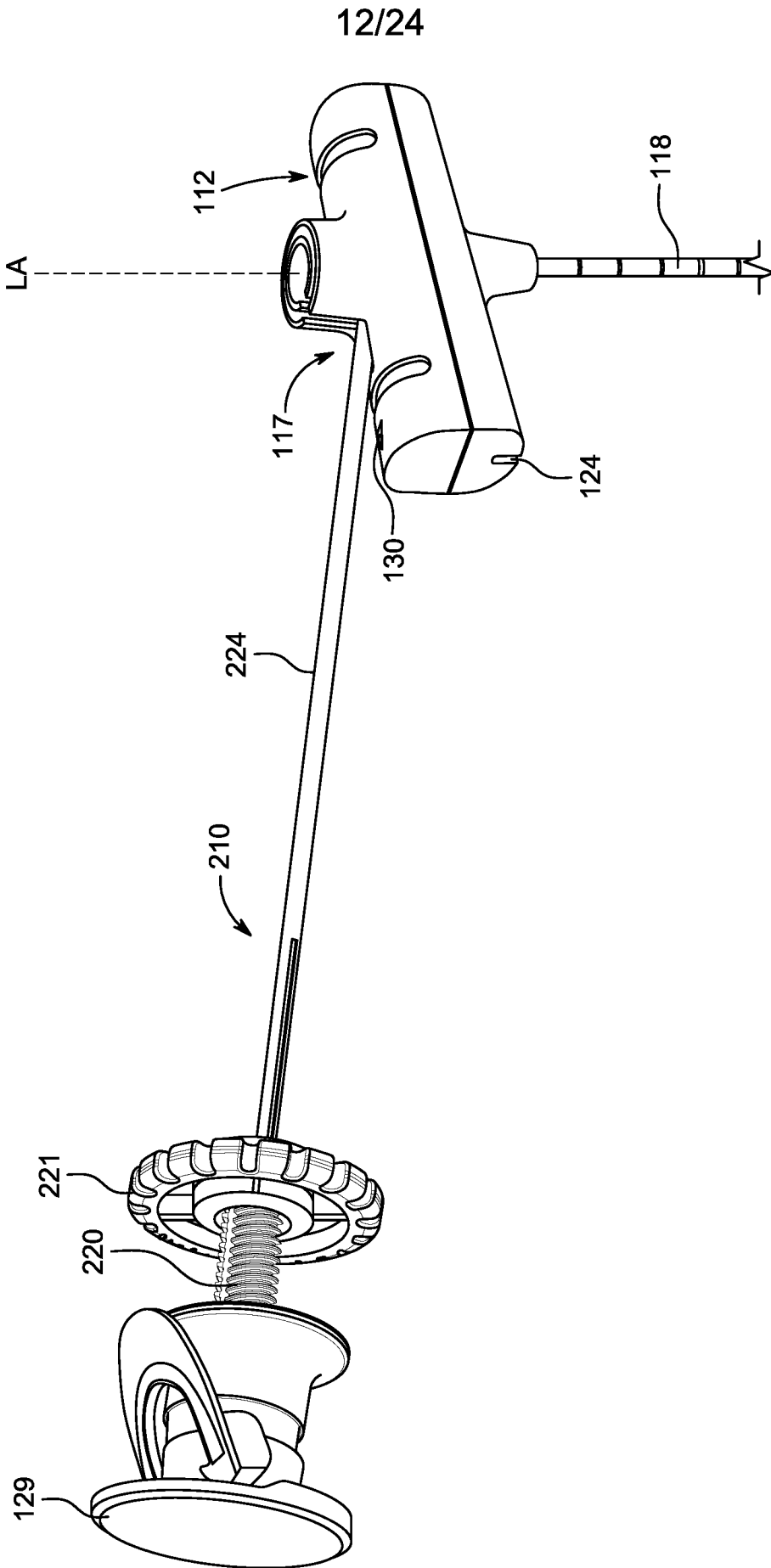

FIG. 3P



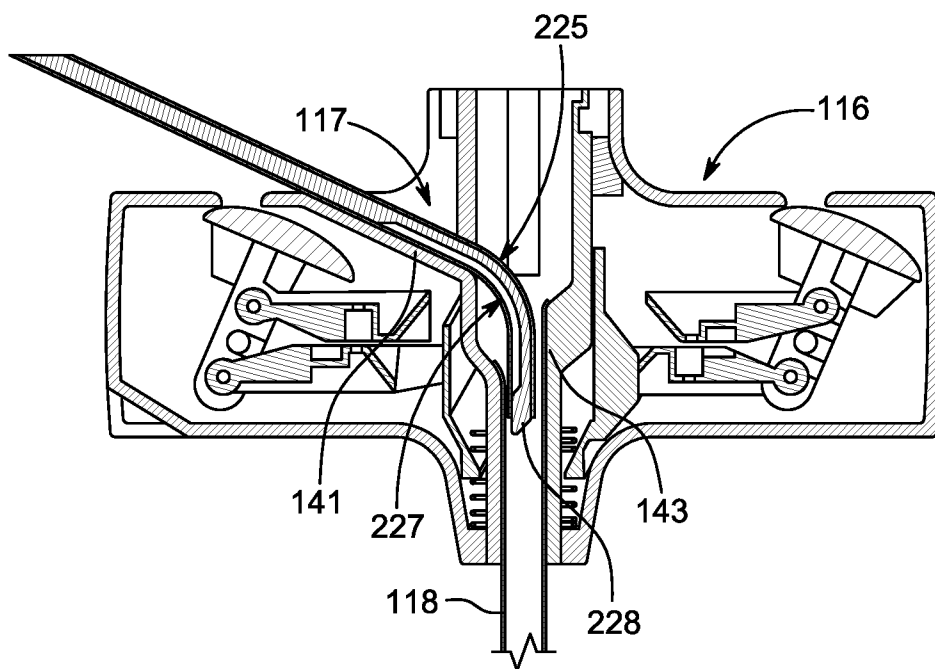

FIG. 3Q

14/24

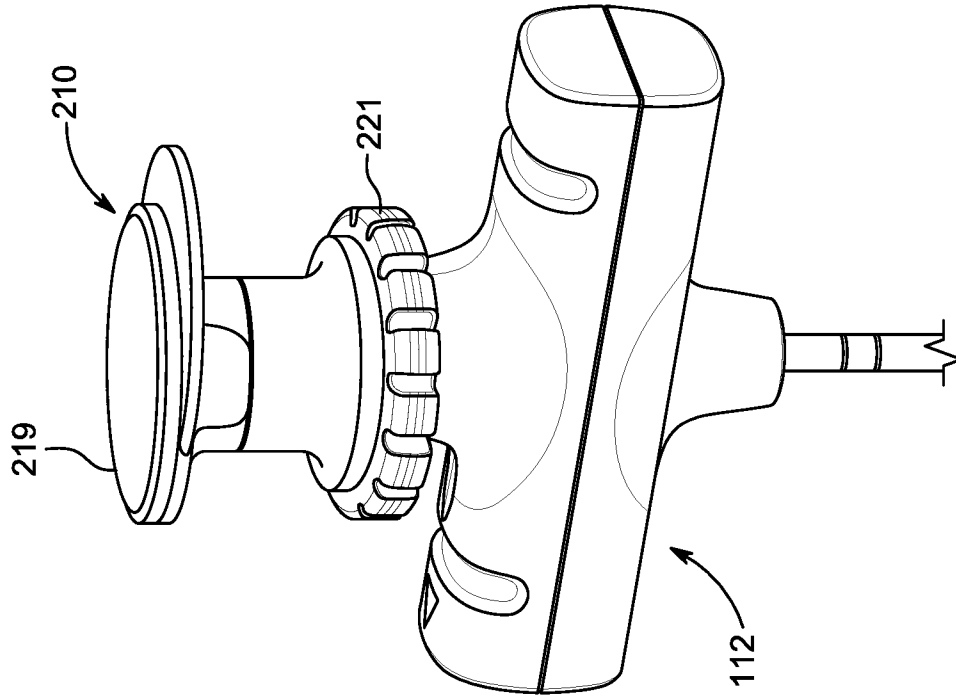

FIG. 3S

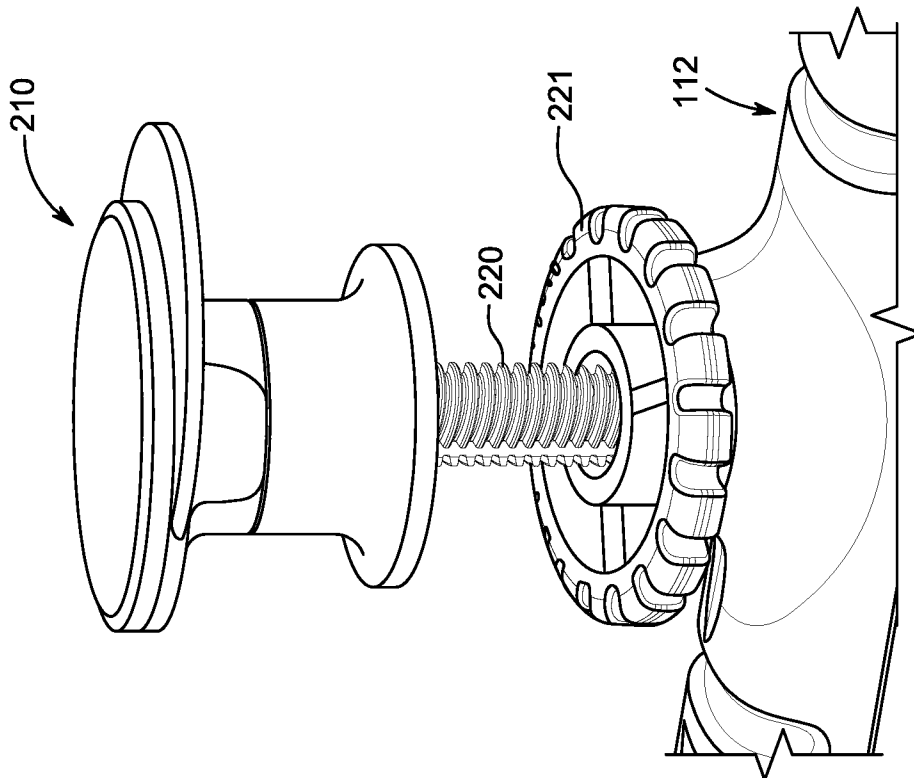

FIG. 3R

15/24

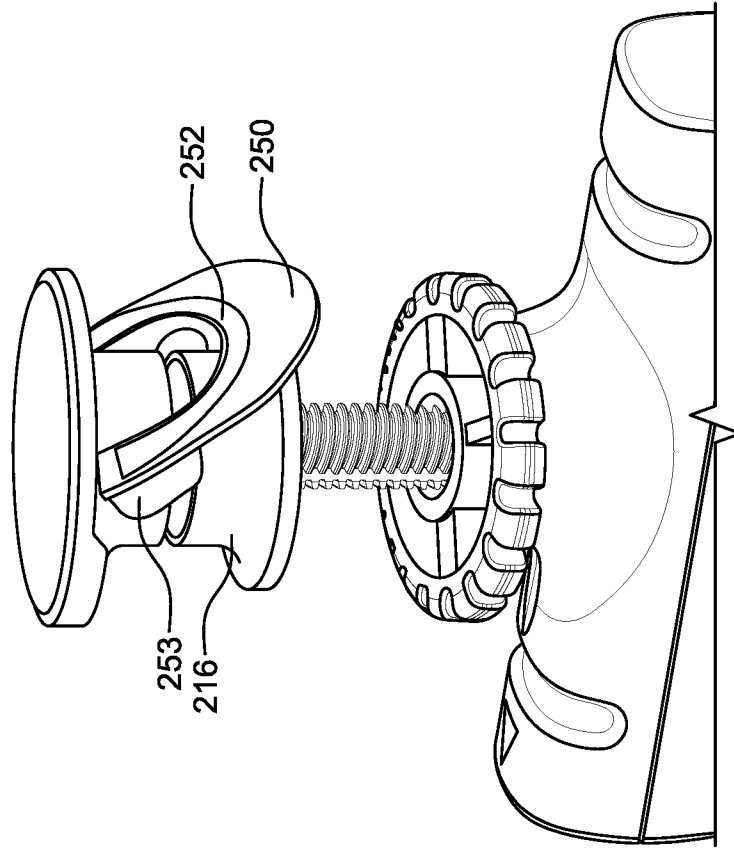

FIG. 3U

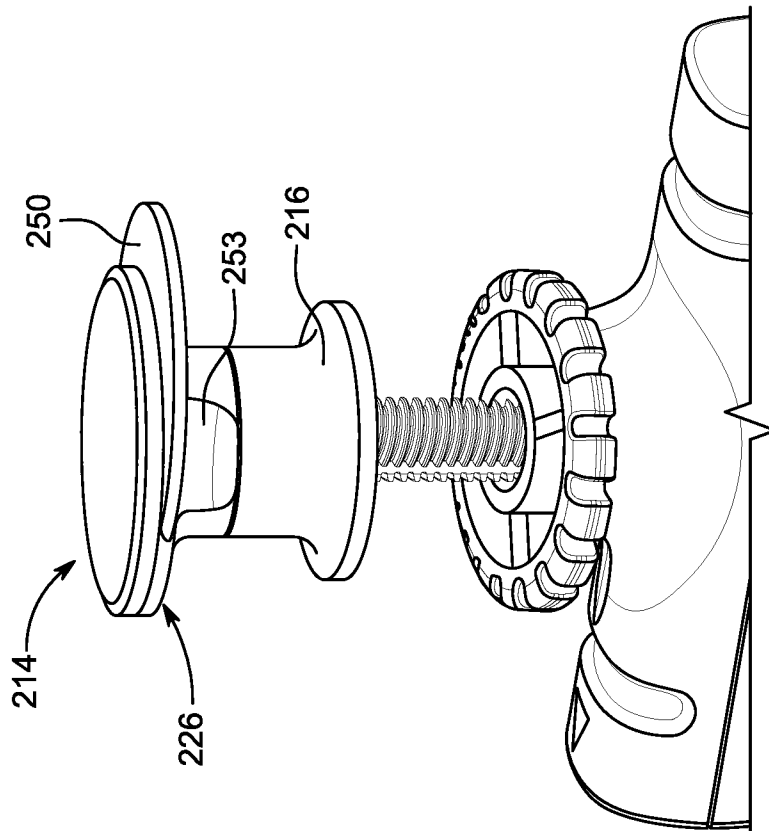

FIG. 3T

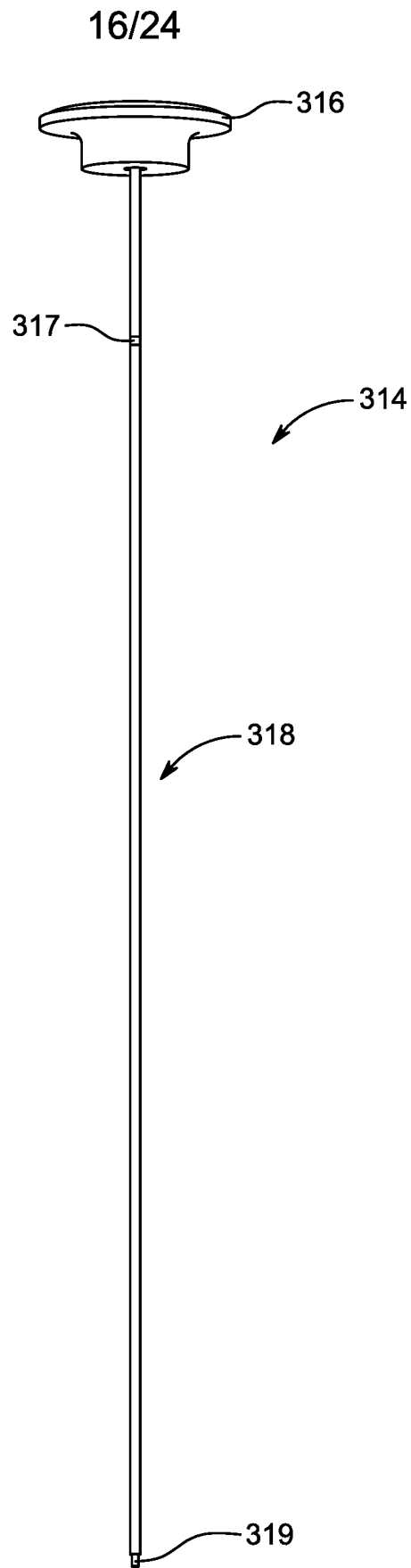

FIG. 3V

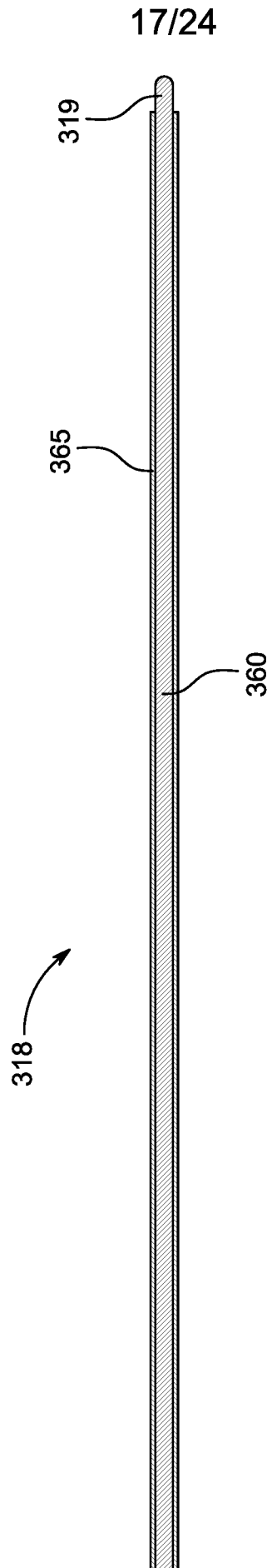

FIG. 3W

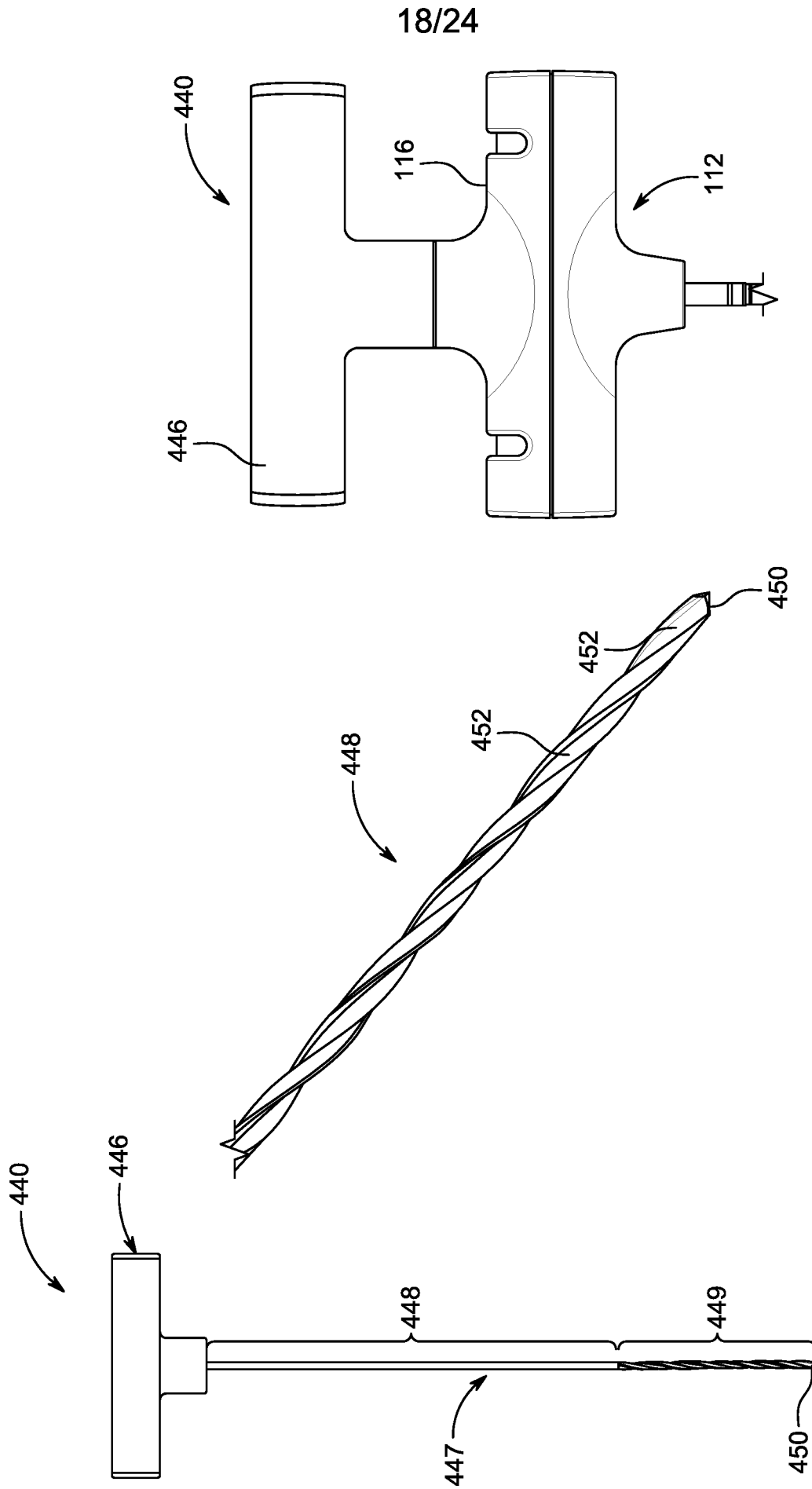

FIG. 3Z

FIG. 3Y

FIG. 3X

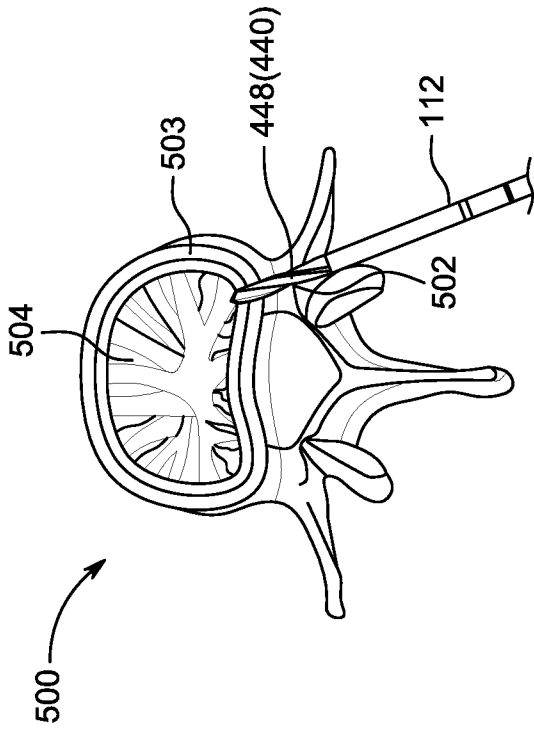

FIG. 3BB

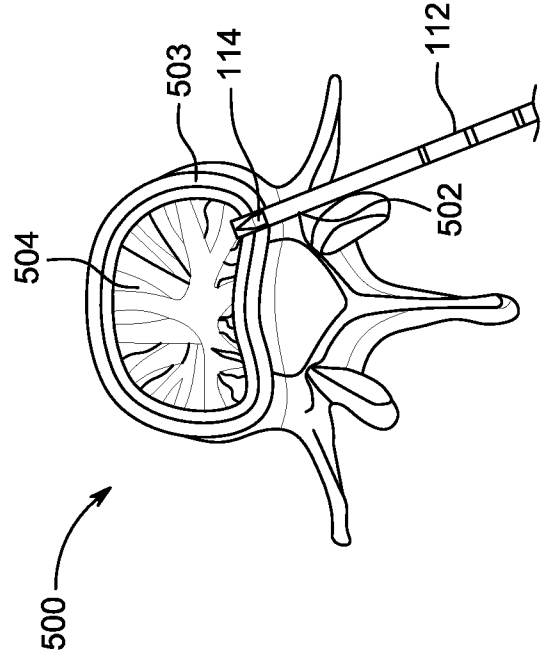

FIG. 3DD

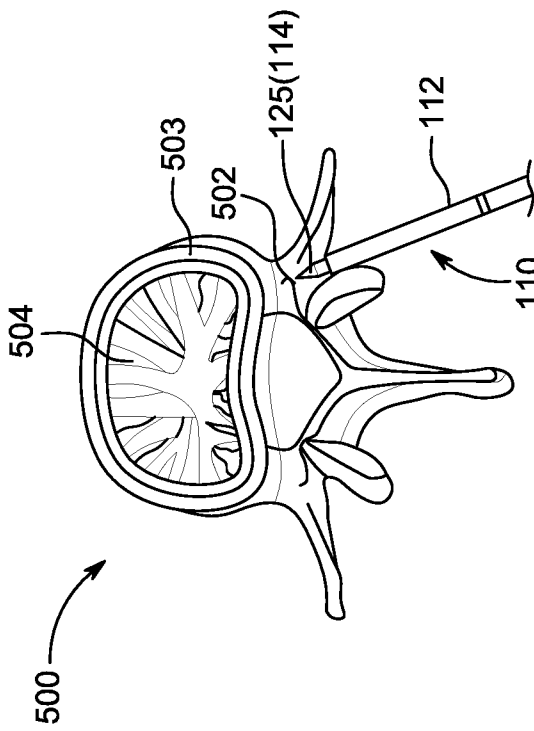

FIG. 3AA

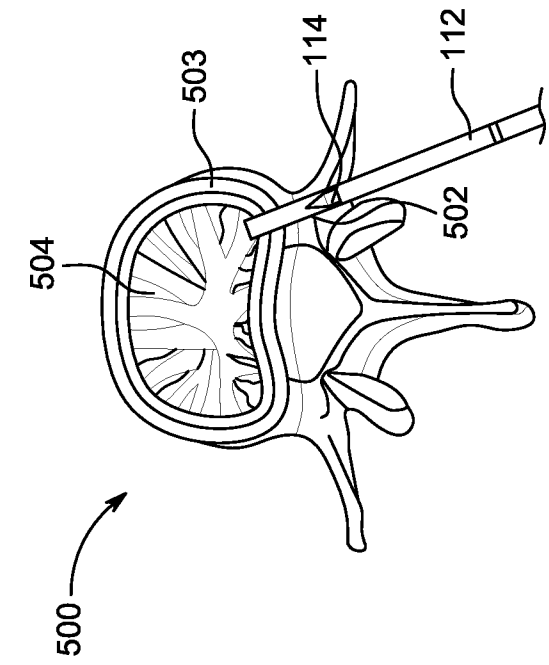

FIG. 3CC

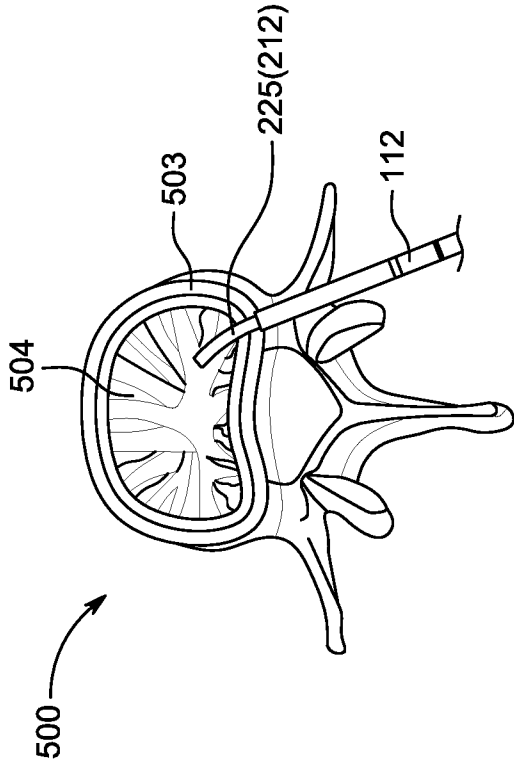

FIG. 3EE

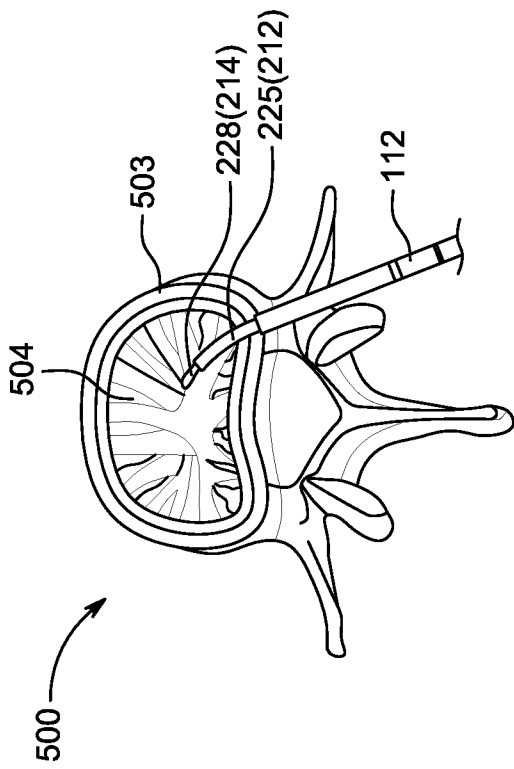

FIG. 3FF

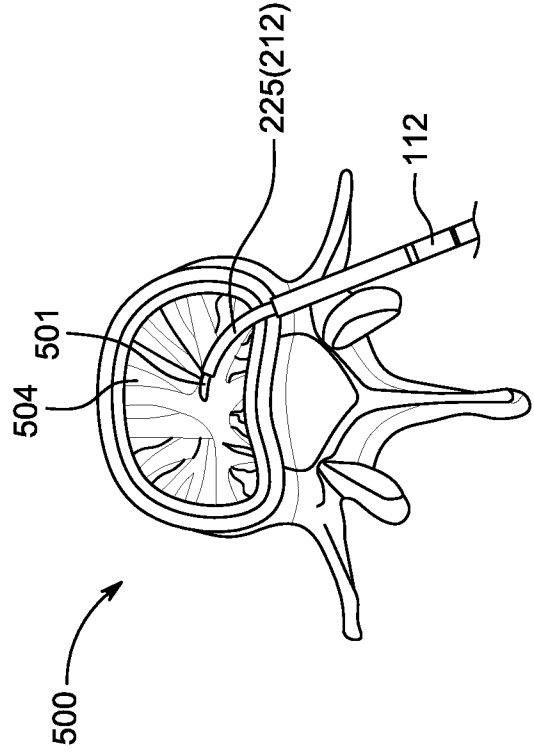

FIG. 3GG

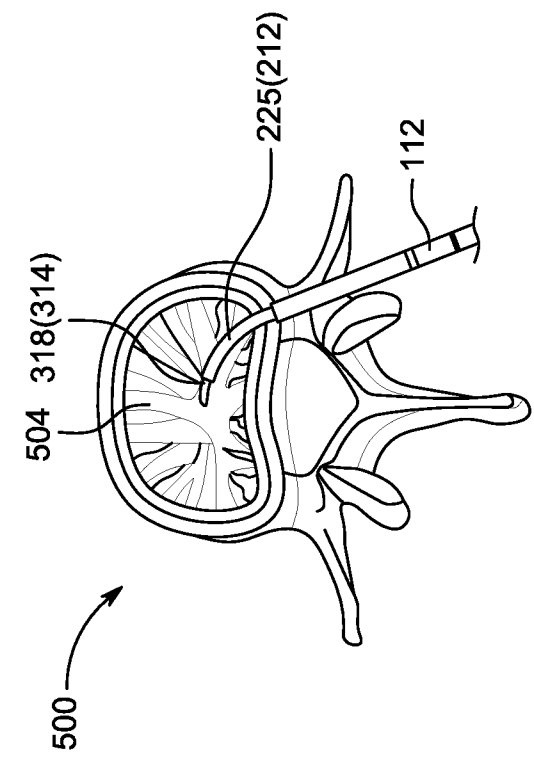

FIG. 3HH



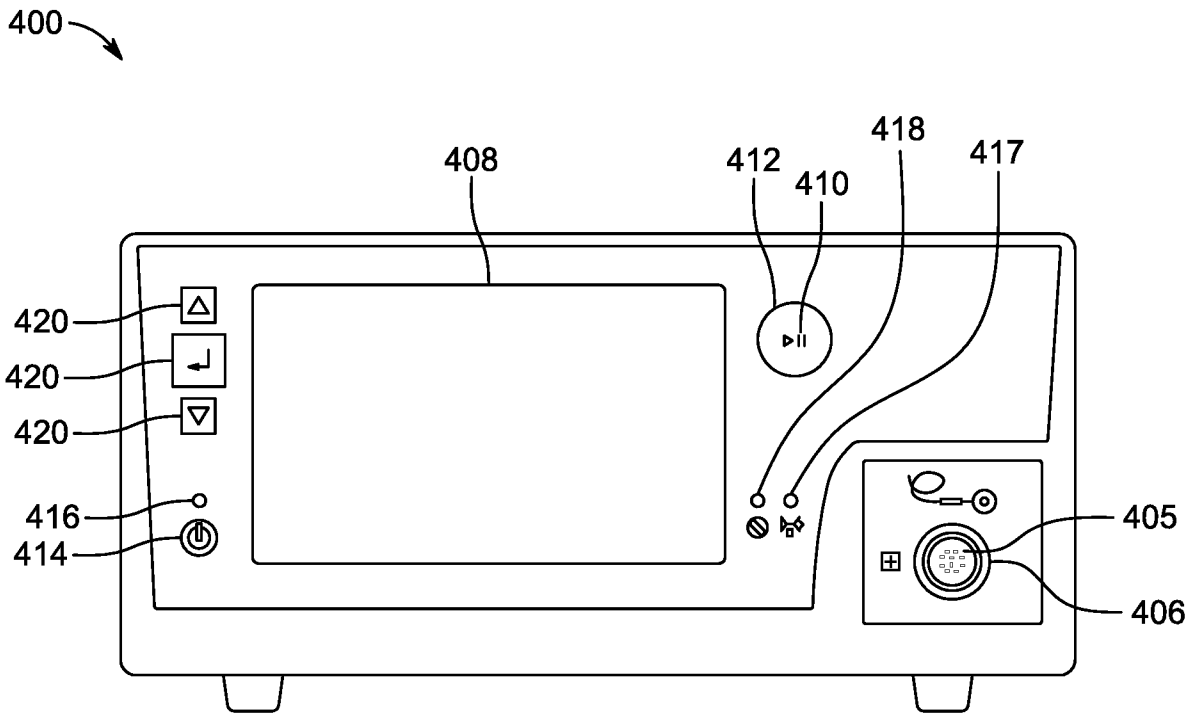

FIGURE 4

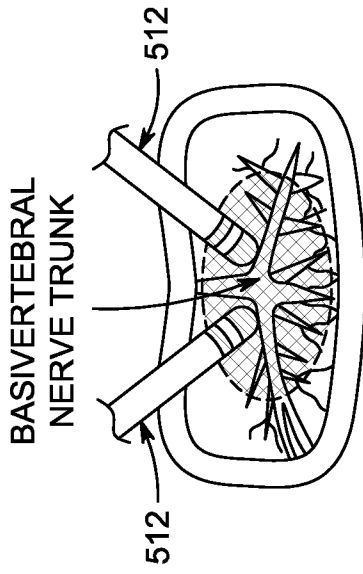

FIGURE 5B

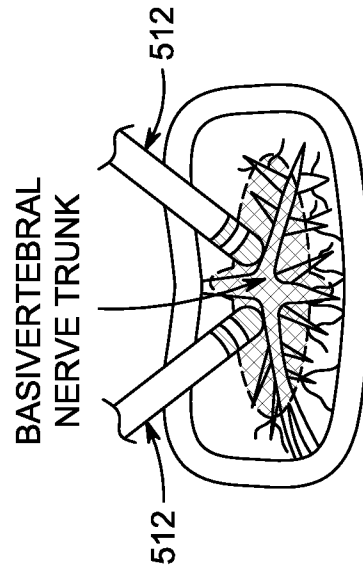

FIGURE 5D

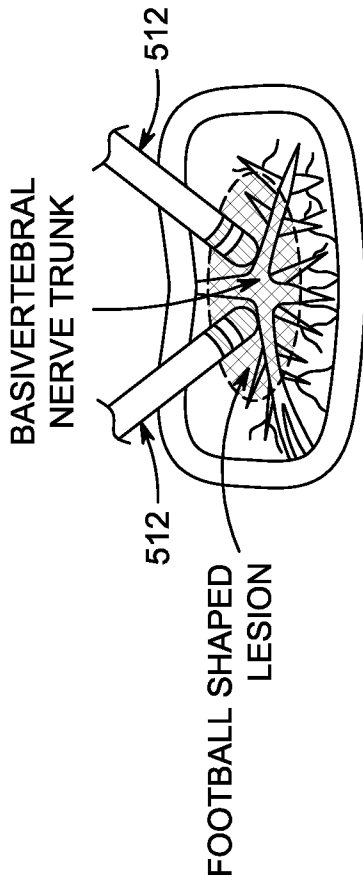

FIGURE 5A

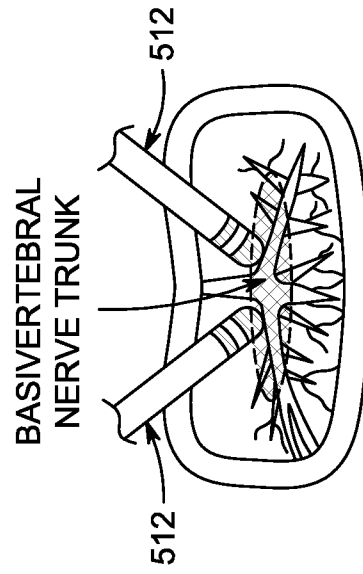

FIGURE 5C

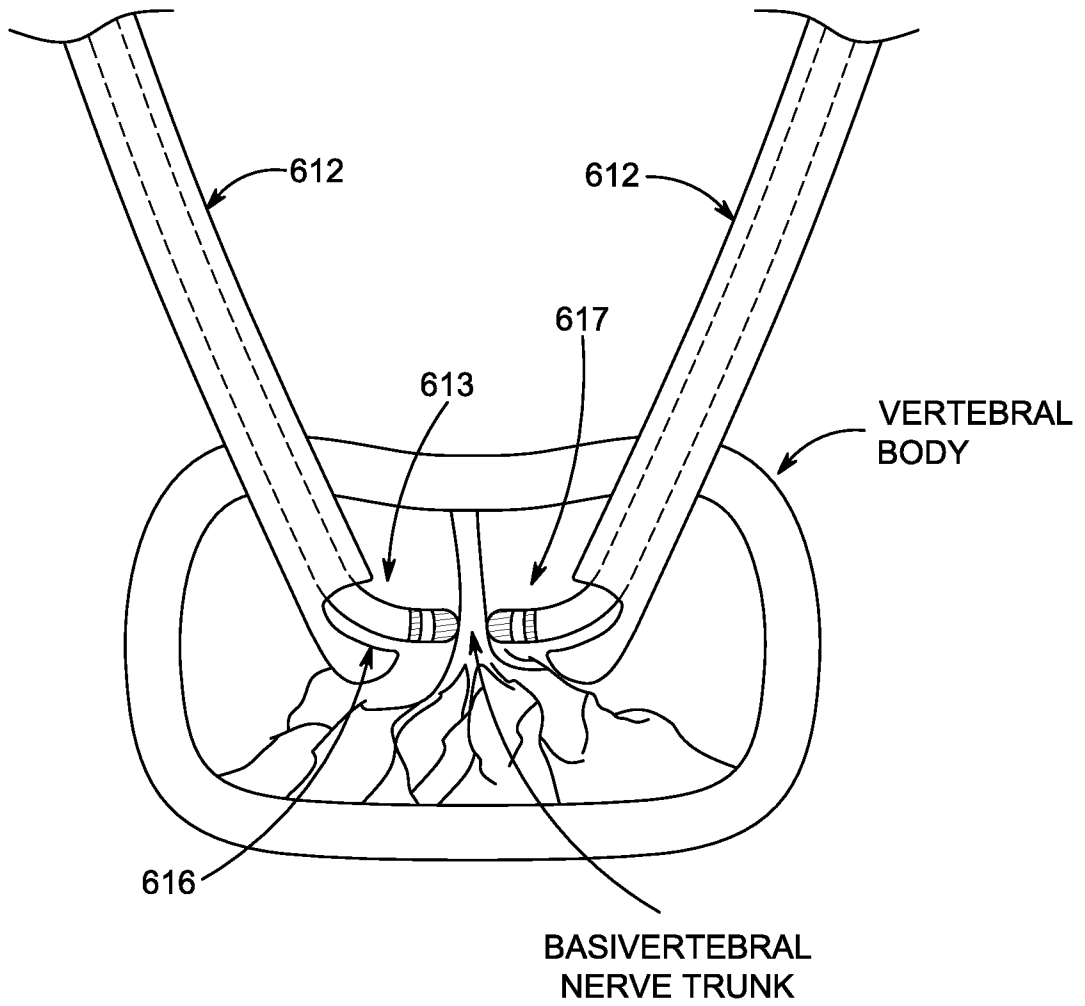

FIGURE 6

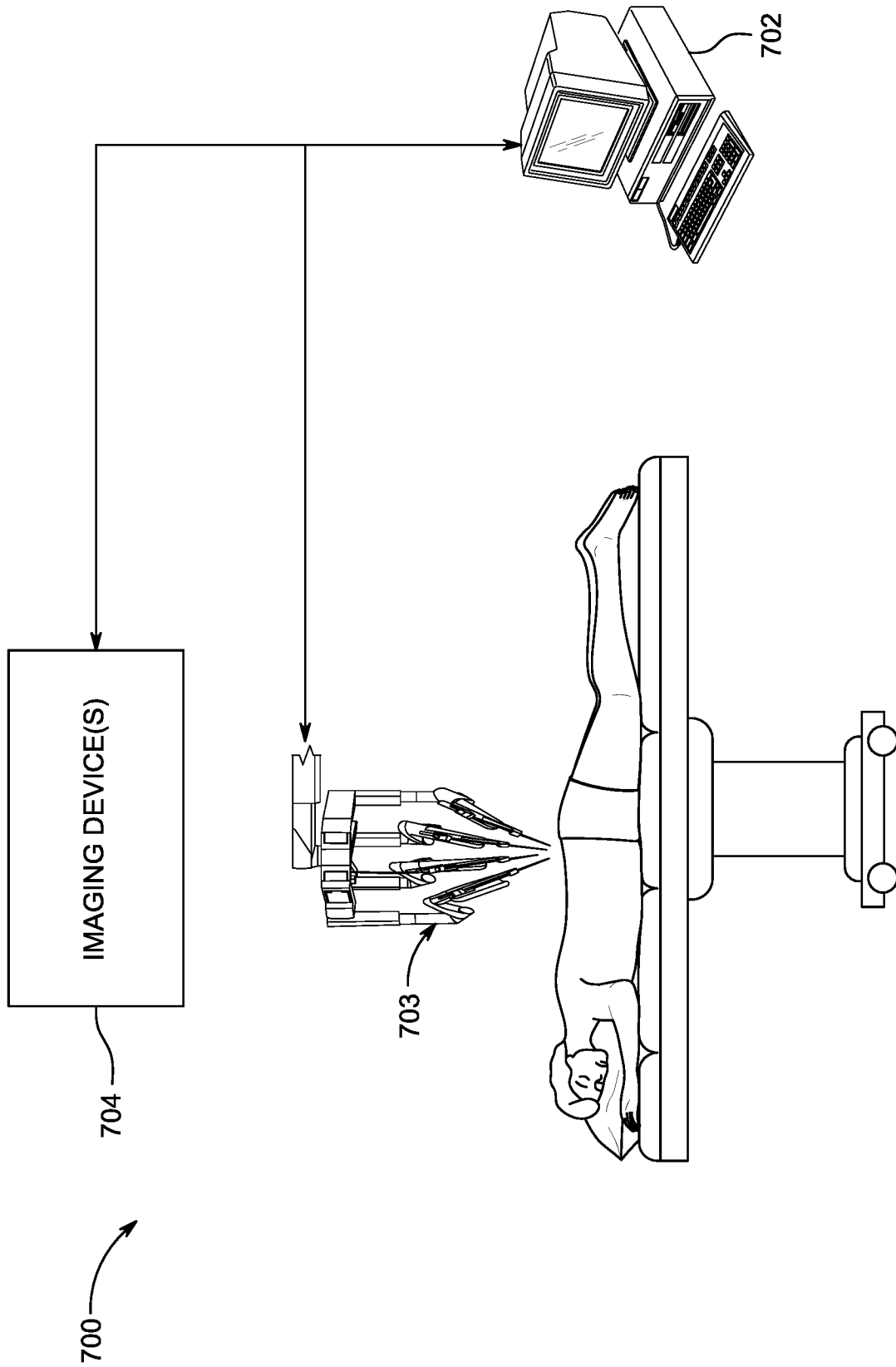

FIGURE 7

## INTERNATIONAL SEARCH REPORT

International application No.

PCT/US 20/50249

## A. CLASSIFICATION OF SUBJECT MATTER

IPC - A61B 17/16; A61B 17/17; A61B 18/18 (2020.01)

CPC - A61B 5/4041; A61B 6/506; A61B 17/1671; A61B 17/1757; A61B 17/3472; A61B 18/18; A61B 18/1815; A61B 2018/00339; A61B 2018/00577

According to International Patent Classification (IPC) or to both national classification and IPC

## B. FIELDS SEARCHED

Minimum documentation searched (classification system followed by classification symbols)

See Search History document

Documentation searched other than minimum documentation to the extent that such documents are included in the fields searched

See Search History document

Electronic data base consulted during the international search (name of data base and, where practicable, search terms used)

See Search History document

## C. DOCUMENTS CONSIDERED TO BE RELEVANT

Category*	Citation of document, with indication, where appropriate, of the relevant passages	Relevant to claim No.
Y — A	US 2015/0005614 A1 (RELIEVANT MEDSYSTEMS, INC.) 01 January 2015 (01.01.2015) Fig 6, 7, 10, 11, abstract, para [0021], [0067]-[0078], [0119]-[0121]	1-8, 10-17, 19-23 <hr/> 9, 24-36
Y — A	US 2014/0194887 A1 (SHENOY) 10 July 2014 (10.07.2014) abstract, para [0012], [0015], [0070]	1-8, 10-17, 19-23 <hr/> 9, 24-36
Y — A	← RAHME et al., "The modic vertebral endplate and marrow changes: pathologic significance and relation to low back pain and segmental instability of the lumbar spine." American Journal of Neuroradiology 29.5 (2008): 838-842 [online] <URL: <a href="http://www.ajnr.org/content/29/5/838">http://www.ajnr.org/content/29/5/838</a> > <DOI: 10.3174/ajnr.A0925>	12, 19 <hr/> 9, 24-36
Y	US 9,241,760 B2 (BAYLIS MEDICAL COMPANY) 26 January 2016 (26.01.2016) abstract, col 11, ln 9-26	20, 22
Y	US 7,238,184 B2 (MEGERMAN et al.) 03 July 2007 (03.07.2007) abstract, col 2, ln 1-58	23
A —	KIM et al., "Transforaminal epiduroscopic basivertebral nerve laser ablation for chronic low back pain associated with modic changes: A preliminary open-label study." Pain Research and Management 2018 (2018) [online] <URL: <a href="https://pubmed.ncbi.nlm.nih.gov/30186540/">https://pubmed.ncbi.nlm.nih.gov/30186540/</a> > <DOI: 10.1155/2018/6857983>.	9, 24-36

 Further documents are listed in the continuation of Box C. See patent family annex.

* Special categories of cited documents:	"T" later document published after the international filing date or priority date and not in conflict with the application but cited to understand the principle or theory underlying the invention
"A" document defining the general state of the art which is not considered to be of particular relevance	
"D" document cited by the applicant in the international application	"X" document of particular relevance; the claimed invention cannot be considered novel or cannot be considered to involve an inventive step when the document is taken alone
"E" earlier application or patent but published on or after the international filing date	
"L" document which may throw doubts on priority claim(s) or which is cited to establish the publication date of another citation or other special reason (as specified)	"Y" document of particular relevance; the claimed invention cannot be considered to involve an inventive step when the document is combined with one or more other such documents, such combination being obvious to a person skilled in the art
"O" document referring to an oral disclosure, use, exhibition or other means	
"P" document published prior to the international filing date but later than the priority date claimed	"&" document member of the same patent family

Date of the actual completion of the international search

28 December 2020

Date of mailing of the international search report

27 JAN 2021

Name and mailing address of the ISA/US

Mail Stop PCT, Attn: ISA/US, Commissioner for Patents  
P.O. Box 1450, Alexandria, Virginia 22313-1450  
Facsimile No. 571-273-8300

Authorized officer

Lee Young

Telephone No. PCT Helpdesk: 571-272-4300

INTERNATIONAL SEARCH REPORT

International application No.

PCT/US 20/50249

**Box No. II Observations where certain claims were found unsearchable (Continuation of item 2 of first sheet)**

This international search report has not been established in respect of certain claims under Article 17(2)(a) for the following reasons:

1.  Claims Nos.:  
because they relate to subject matter not required to be searched by this Authority, namely:
  
2.  Claims Nos.:  
because they relate to parts of the international application that do not comply with the prescribed requirements to such an extent that no meaningful international search can be carried out, specifically:
  
3.  Claims Nos.: 18, 37, 38, 85, 86  
because they are dependent claims and are not drafted in accordance with the second and third sentences of Rule 6.4(a).

**Box No. III Observations where unity of invention is lacking (Continuation of item 3 of first sheet)**

This International Searching Authority found multiple inventions in this international application, as follows:  
This application contains the following inventions or groups of inventions which are not so linked as to form a single general inventive concept under PCT Rule 13.1. In order for all inventions to be searched, the appropriate additional search fees must be paid.

Group I: Claims 1-17, 19-36 drawn to a method of detecting and treating back pain of a subject.

Group II: Claims 39-45 drawn to an introducer system adapted to facilitate percutaneous access to a target treatment location within bone.

Group III: Claims 46-52 drawn to a system configured to provide curved access within bone.

Group IV: Claims 53-59 drawn to a method of accessing a target treatment location within a vertebral body identified as having hard bone.

—see extra sheet

1.  As all required additional search fees were timely paid by the applicant, this international search report covers all searchable claims.
2.  As all searchable claims could be searched without effort justifying additional fees, this Authority did not invite payment of additional fees.
3.  As only some of the required additional search fees were timely paid by the applicant, this international search report covers only those claims for which fees were paid, specifically claims Nos.:
  
4.  No required additional search fees were timely paid by the applicant. Consequently, this international search report is restricted to the invention first mentioned in the claims; it is covered by claims Nos.:  
1-17, 19-36

**Remark on Protest**

- The additional search fees were accompanied by the applicant's protest and, where applicable, the payment of a protest fee.
- The additional search fees were accompanied by the applicant's protest but the applicable protest fee was not paid within the time limit specified in the invitation.
- No protest accompanied the payment of additional search fees.

Continuation of Box No III – Observations where unity of invention is lacking

Group V: Claims 60-69 drawn to a method of ablating a basivertebral nerve within a vertebral body of a subject and confirming efficacy of ablation of the basivertebral nerve.

Group VI: Claims 70-76 drawn to a method of treating a vertebral body including details of first and second radiofrequency devices creating a lesion of a particular shape.

Group VII: Claims 77-81 drawn to a method or a system for ablating a basivertebral nerve including details of robotics.

Group VIII: Claims 82-84 drawn to a radiofrequency ("RF") generator for facilitating nerve ablation including details of indicator light rings.

Group IX: Claim 87 drawn to a kit for facilitating nerve ablation including details of biological assays.

The inventions listed as Groups I through IX do not relate to a single general inventive concept under PCT Rule 13.1 because, under PCT Rule 13.2, they lack the same or corresponding special technical features for the following reasons:

**Special Technical Features:**

Group I includes the special technical features of determining a pre-Modic change for treating back pain, not included in the other groups.

Group II includes the special technical features of an introducer cannula comprising a proximal handle and a distal elongate hypotube extending from the proximal handle; and an introducer stylet comprising a proximal handle and a distal elongate shaft extending from the proximal handle, wherein the proximal handle of the introducer cannula comprises a central opening in its upper surface that is coupled to a lumen of the distal elongate hypotube to facilitate insertion of the introducer stylet into the central opening and into the distal elongate hypotube, wherein the proximal handle of the introducer cannula comprises one or more slots configured to receive at least a portion of the proximal handle of the introducer stylet so as to facilitate engagement and alignment between the introducer stylet and the introducer cannula, wherein the proximal handle of the introducer stylet comprises an anti-rotation tab configured to be received within one of the one or more slots so as to prevent rotation of the introducer stylet within the introducer cannula, and wherein a distal end of the distal elongate shaft of the introducer stylet comprises a distal cutting tip and a scalloped section proximal to the distal cutting tip so as to provide gaps between an outer diameter of the distal end of the distal elongate shaft and the inner diameter of the introducer cannula, not included in the other groups.

Group III includes the special technical features of a cannula comprising a proximal handle with a curved insertion slot and a distal polymeric tube, wherein the distal polymeric tube comprises a curved distal end portion having a preformed curvature but configured to bend when placed under constraint; a stylet comprising a proximal handle and a distal elongate shaft, wherein the distal elongate shaft comprises a curved distal end portion having a preformed curvature but configured to bend when placed under constraint and a distal channeling tip, and wherein a length of the curved distal end portion of the distal elongate shaft proximal to the distal channeling tip comprises a cross-section circumference profile that is less than a full cross-section circumference profile such that there is a larger gap between an outer cross-sectional dimension of the curved distal end portion of the distal elongate shaft and the inner diameter of the curved distal end portion of the cannula along the length, not included in the other groups.

Group IV includes the special technical features of advancing an introducer assembly through skin adjacent the vertebral body and into a pedicle connected to the vertebral body, the introducer assembly comprising an introducer stylet inserted within an introducer cannula with a distal cutting tip of the introducer stylet extending out of the introducer cannula; removing the introducer stylet from the introducer cannula while leaving the introducer cannula in place; inserting an introducer drill through and beyond the introducer cannula and through the pedicle and into cancellous bone of the vertebral body, wherein inserting the introducer drill comprises rotating the introducer drill, wherein the introducer drill comprises a fluted distal portion and a distal drill tip, and wherein drill flutes of the fluted distal portion taper away from the distal drill tip so as to facilitate improved bone chip packing within an open volume defined by the drill flutes as bone chips are generated by operation of the introducer drill, not included in the other groups.

Group V includes the special technical features of obtaining a baseline reading of a level of a biomarker from the subject; performing a denervation procedure on the subject, wherein the denervation procedure comprises denervating the basivertebral nerve within the vertebral body; obtaining a post-procedure reading of the level of the biomarker from the subject; and determining an effect of the denervation procedure by comparing the postprocedure reading to the baseline reading, not included in the other groups.

Group VI includes the special technical features of inserting a first access assembly into a first target location of the vertebral body, the first access assembly comprising a first cannula and a first stylet; removing the first stylet from the first cannula; inserting a second access assembly into a second target location of the vertebral body, the second access assembly comprising a second cannula and a second stylet; removing the second stylet; inserting a first radiofrequency energy delivery device through the first cannula, the first radiofrequency energy delivery device comprising at least two electrodes; inserting a second radiofrequency energy delivery device through the second cannula, the second radiofrequency energy delivery device comprising at least two electrodes; positioning the at least two electrodes of the first radiofrequency energy delivery device within the vertebral body; positioning the at least two electrodes of the second radiofrequency energy delivery device within the vertebral body; and applying power to the first and second radiofrequency energy delivery devices sufficient to create a lesion within the vertebral body having a shape selected from one of the following: football shape, cigar shape, X shape, cross shape, or UFO shape, not included in the other groups.

Group VII includes the special technical features of inserting a radiofrequency energy delivery device through the cannula to a target treatment site within the vertebral body using a robotically-controlled system or ablating a basivertebral nerve within one or more vertebral bodies using automated robotic surgical arms, not included in the other groups.

--see next page

continuation of previous page

Group VIII includes the special technical features of a display screen; an instrument connection port; a first indicator light ring surrounding the instrument connection port that is configured to illuminate when a treatment device is connected to the instrument connection port, wherein the first indicator light ring is configured to continuously illuminate in a solid color when the treatment device is connected to the instrument connection port, to flash at a first pulsing rate to prompt a clinician to connect the treatment device to the instrument connection port, and to flash at a second pulsing rate different than the first pulsing rate to indicate an error condition; an energy delivery actuation button configured to be pressed by an operator to start and stop delivery of radiofrequency energy; and a second indicator light ring surrounding the actuation button, wherein the second indicator light ring is configured to continuously illuminate in a solid color when the generator is powered on and ready to initiate energy delivery, to flash at a third pulsing rate to prompt the operator to press the actuation button to initiate energy delivery, and to flash at a fourth pulsing rate different than the third pulsing rate when energy delivery has been paused or stopped, not included in the other groups.

Group IX includes the special technical features of one or more biological assays, wherein said one or more biological assays are configured to determine at least one biological marker, wherein said determination comprises at least one of: binary detection of a presence of said at least one biological marker, and/or a quantification of said at least one biological marker, not included in the other groups.

**Common Technical Features:**

The only technical features shared by two or more of the Groups that would otherwise unify the Groups, are treating a vertebral body, ablating a basivertebral nerve, application of radiofrequency energy, and a cannula comprising a proximal handle and a distal cutting tip. However, these shared technical features do not represent a contribution over prior art, because the shared technical features are disclosed by US 9,775,627 B2 to Relievan Medsystems, Inc. (hereinafter 'Relievan').

Relievan discloses treating a vertebral body (abstract, col 1, ln 7-12), ablating a basivertebral nerve, application of radiofrequency energy (col 9, ln 53-col 10, ln 5, "... basivertebral nerve...radiofrequency ablation.."), and a cannula (50) comprising a proximal handle (24) and a distal cutting tip (84) (Fig 1, 2, col 18, ln 18-39, "...The system comprises a needle trocar 20 (the main body of the instrument set). The trocar 20 comprises an elongate shaft 28 having a handle 24 at its proximal end 32...further comprises a straight stylet 80 having a sharp-tipped needle 84 at its distal end...curved cannula 50 that is used to create/maintain the curved path within the bone/tissue..")

As the shared technical features were known in the art at the time of the invention, they cannot be considered special technical features that would otherwise unify the groups.

Therefore, Groups I-IX lack unity under PCT Rule 13.

Claims 18, 37, 38, 85 and 86 are determined to be unsearchable because they are dependent claims and are not drafted in accordance with the second and third sentences of Rule 6.4(a) and are, therefore, not included in any claim group.