

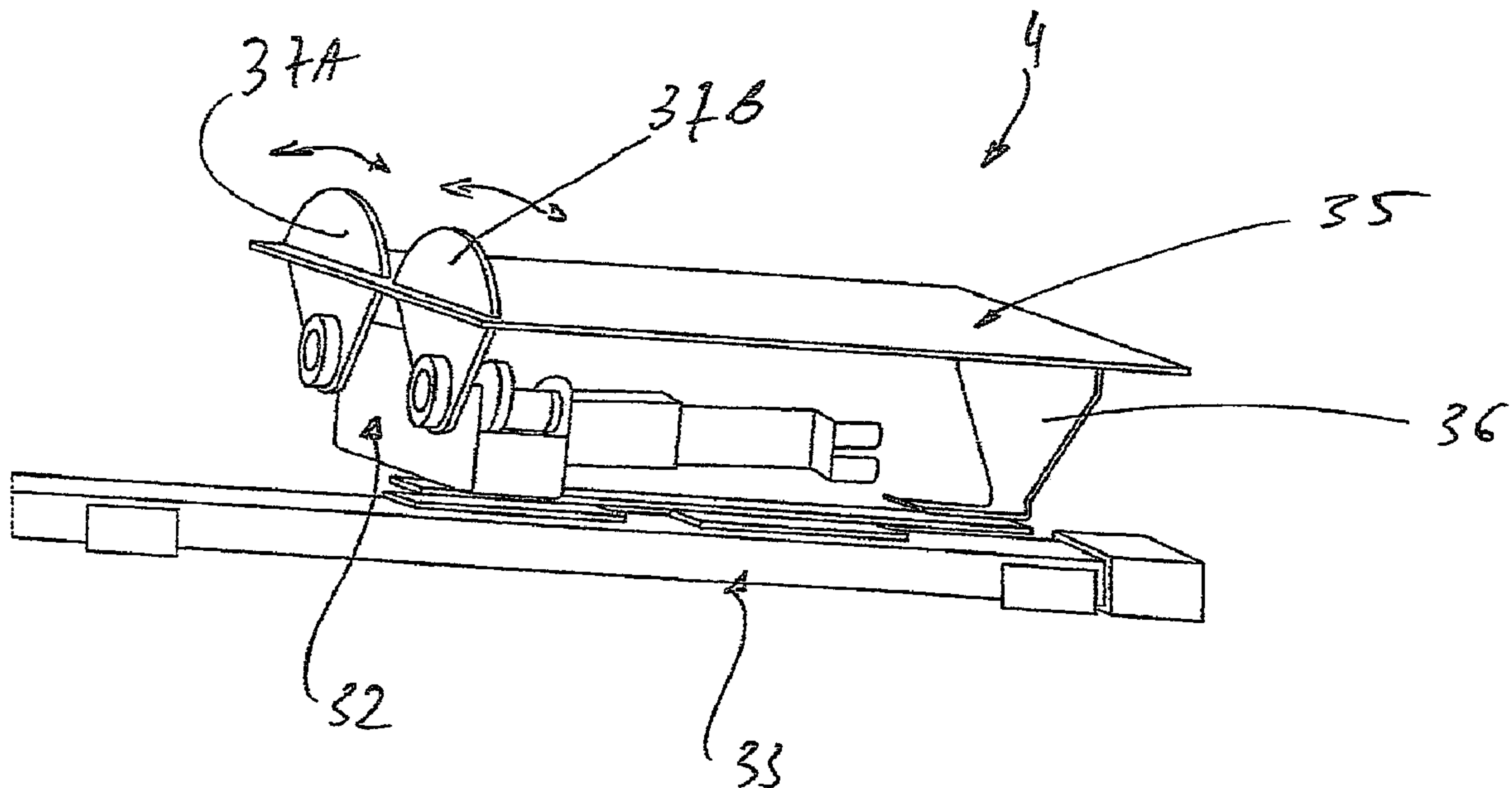

(86) **Date de dépôt PCT/PCT Filing Date:** 2013/06/26  
(87) **Date publication PCT/PCT Publication Date:** 2014/01/09  
(45) **Date de délivrance/Issue Date:** 2019/06/18  
(85) **Entrée phase nationale/National Entry:** 2014/12/17  
(86) **N° demande PCT/PCT Application No.:** EP 2013/063343  
(87) **N° publication PCT/PCT Publication No.:** 2014/005894  
(30) **Priorité/Priority:** 2012/07/06 (DE10 2012 106 111.4)

(51) **Cl.Int./Int.Cl. B65G 57/03** (2006.01),  
**B65G 57/10** (2006.01), **B65G 57/22** (2006.01)  
(72) **Inventeur/Inventor:**  
CAVELIUS, JORG, DE  
(73) **Propriétaire/Owner:**  
DEMATIC GMBH, DE  
(74) **Agent:** R. WILLIAM WRAY & ASSOCIATES

(54) **Titre : DISPOSITIF POUR EMPILER DES ARTICLES EN PLUSIEURS COUCHES SUR UN SUPPORT**  
(54) **Title: DEVICE FOR LAYERED STACKING A SUPPORT**



(57) **Abrégé/Abstract:**

The invention relates to a device for automatically stacking packages on a support comprising: at least one feeding conveyor; a lifting and lowering unit for lifting and lowering a palette; a position conveyor (4) embodied as a travel container, which is arranged horizontally and longitudinally to one side of the storage place, in order to position the packages in the X-direction; at least one sliding plate and a pusher in order to transport the packages from the travel path in the Z-direction to the predetermined position in the stack (S). The at least one sliding plate can be embodied as a flat, strip-like plate so that it can move horizontally and longitudinally on the side of the storage place and transversally thereto, in order to remove the packages from the positioning conveyor in the X direction position when pushed by the pusher and arranging on the palette in the Z-direction. The travel container contains pivotable stops (37A, 37B) and can be moved on rails.

## Abstract

The invention relates to a device for automatically stacking packages on a support comprising: at least one feeding conveyor; a lifting and lowering unit for lifting and lowering a palette; a positioning conveyor (4) embodied as a travel container, which is arranged horizontally and longitudinally to one side of the storage place, in order to position the packages in the X-direction; at least one sliding plate and a pusher in order to transport the packages from the travel path in the Z-direction to the predetermined position in the stack (S). The at least one sliding plate can be embodied as a flat, strip-like plate so that it can move horizontally and longitudinally on the side of the storage place and transversally thereto, in order to remove the packages from the positioning conveyor in the X direction position when pushed by the pusher and arranged on the palette in the Z-direction. The travel container contains pivotable stops (37A, 37B) and can be moved on rails.

Device for layered stacking a support

The invention relates to a device for automatically stacking packages on a support in a predetermined spatial arrangement to form a stack.

5

Automatic stacking of a support or a carrier, in particular a pallet or a trolley, with packages to form a stack for subsequent shipment, i.e. "palletising" is known *per se*. However, in that case packages of uniform size or dimension are placed by robots, grabbers etc. into arithmetically determined locations.

10

In contrast, the process of automatically loading a load carrier with packages of different characteristics to form a stack is the so-called automatic "mixed-case" palletising.

15 Current distribution logistics place ever increasing demands upon picking. Therefore, it is necessary to develop picking systems which process orders automatically without manual intervention.

Thousands of different products (or packages) of the most varied characteristics (size, 20 shape, weight, dimensions, surfaces etc.) must be picked automatically in such systems.

In that case, it is necessary to take into account various aspects which enormously increase the complexity in comparison with "simple" manual stacking of simple, 25 regular geometries. For instance, a subsequent package can only be stacked or placed effectively onto a preceding package if the latter comprises a flat or planar surface which should also be oriented approximately in a horizontal manner, and if the package can support the weight of the further packages, which are placed thereon, without being damaged.

30

Furthermore, the stack which is formed should comprise a certain level of stability, *inter alia* to ensure that it does not fall over during transportation. Although a film wrapping helps, it cannot stabilise an incorrectly formed stack on its own.

35 Furthermore, customers demand with increasing frequency that the stacks are

optimised by reason of the desired unloading sequence.

Therefore, different packages or goods of a different size or dimension are generally still stacked manually, as the requirements placed on the stability of the stack, the packing density within the stack and the sequence of loading and the resulting unloading sequence and not least the stacking capability of the goods are extremely high and to date have not been fulfilled or have only been partly fulfilled by the known methods and devices.

5  
10 EP 1 462 394 B1 discloses a device for automatically loading a load carrier with packing units which form a stack, i.e. a device for palletising. In the case of the device, the packing units are fed lying supported and individually on trays from where they are placed onto a packing table. At this location, the packing unit, lying on the table, is displaced by a pusher along the broad side of the pallet to be loaded until the loading coordinates in the X-direction are reached. Subsequently, a further pusher and a loading tongue simultaneously push the packing unit in the direction of the load depth over the pallet until the loading coordinates in the Z-direction are reached. Subsequently, the loading tongue moves back, wherein the pusher remains stationary and serves as a scraper, so that the packing unit is placed "free-falling" at the desired position on the pallet. The stack which forms is supported by a loading aid on the remaining three sides. Stacking thus occurs as it were "against the wall". However, the displacement on the packing table is time consuming and owing to the restricted accessibility has disadvantages when forming the packing patterns. Moreover, it is vital that the loading tongue and the scraper/pusher move simultaneously in the X-direction. Also, only one packing unit can ever be "processed" sequentially.

15  
20  
25  
30 WO 2010/059923 A1 discloses an automatic robot-assisted device for stacking, in which an intermediate plate is used for forming the first tier of a stack and simultaneously changing the pallet.

35 In contrast thereto, the object of the present invention is to provide a method and a device for automatically stacking packages onto a carrier in a predetermined spatial arrangement to form a stack, which method or device permits in a flexible manner mixed-case stacking at a high throughput rate.

This object is achieved by the device described in claim 1. Advantageous embodiments are apparent from the subordinate claims and the description.

In accordance with the invention, the positioning conveyor is designed as a transfer  
5 cart or shuttle which can travel back and forth on rails arranged in the X-direction along the stacking location or the support for it and transports in each case one package to the designated X-position.

Preferably, the transfer cart is designed having a C-shaped frame, so that the at least  
10 one sliding plate can engage through between the limbs of the "C", so as to prevent any mutual hindrance. This also renders it possible that once the "transfer" of the package to the sliding plate has been effected, the transfer cart already travels back to receive the next package from the feeding conveyor before the stacking procedure is completed. The actual carrier surface for the package is thus fastened only on one  
15 side to the travelling mechanism of the transfer cart and protrudes at this location.

In order to ensure that the packages do not fall down from the transfer cart and are precisely positioned, the transfer cart comprises a stop on the side facing away from the feeding conveyor in the X-direction. In a particularly preferred embodiment, the  
20 stop is movable, preferably foldable or pivotable, away from the stop position, so that after "transfer" of the package to the sliding plate has been effected (cf. above), the transfer cart is already able to "fetch" the next package.

For instance, the stop is designed to be movable away from the stop position. For this  
25 purpose, the stop can preferably be pivoted about an axis from the stop position to a release position. This embodiment does not require much space and also does not "collide" with the sliding plates. It is expedient if the stop comprises two stop wings which are pivotable in opposite directions, in order to provide a broad stop or surface.

If, as in the case of the prior art, an individual pusher is not used but instead the  
30 pusher is designed as an arrangement of a plurality of individual pushers arranged horizontally and along the side of the stacking location, i.e. designed as a bank of pushers, which effect pushing of the packages from the positioning conveyor in the direction of the stack, wherein the individual pushers are movable in the Z-direction  
35 independently of the at least one sliding plate, in order to retain the package when the

sliding plate is being retracted, the packages can still be positioned in a more variable manner and moreover a plurality of packages can be stacked with less of a time offset or even simultaneously.

5 In a particularly preferred variant, not all of the individual pushers comprise a dedicated drive but instead have at least one, preferably two, common drives which can be coupled optionally to a specific individual pusher to drive same. For this purpose, the drive can be movable and can enter into engagement with a drive carriage of the respective (adjacent) pusher(s) via a coupling element.

10

The individual pushers are thus suspended from a frame, on which they are movable in the Z-direction towards (or away from) the stack. For this purpose, they are approached by a carriage or cross member which is arranged above and extends transversely thereto, i.e. in the X-direction, and supports a drive, wherein a coupling or entraining element establishes the operative connection between the drive and the individual pusher. The entraining element is suspended in the manner of a sheet or strip from the drive or the travelling cross member thereof and engages into a groove, which is open at the top, on the drive carriage of the adjacent individual pusher(s), for which reason the entraining element is of a corresponding width.

15

Preferably, two such movable common drives are provided, one coming from each side in the X-direction of the frame and one positioned upstream and downstream in the X-direction with respect to the stacking location.

20

The arrangement of the individual pushers can extend over the entire length of the positioning conveyor, then the individual pushers can be designed to be unmovable in the X-direction or conveying direction of the positioning conveyor. Alternatively, it is also feasible to provide correspondingly fewer individual pushers, but at least two, and then to design same to be adjustable in the X-direction for balancing purposes.

25

In a preferred embodiment, the at least one sliding plate is designed as a flat, strip-like plate which is designed to be movable horizontally and along the side of the stacking location and transversely thereto and which becomes thinner in the direction of the stacking location. The sliding plate is suspended on the side of the positioning conveyor opposite the carrier. At this location, it is optionally attached to the same

30

35

frame as the individual pushers. If more than one sliding plate is present, they can be arranged in parallel and next to one another.

5 It is preferred if the at least one sliding plate is movable back and forth in the manner of a carriage in each case on a linear axle oriented in the Z-direction. Therefore, it can be extended or retracted in simple manner into the required Z-direction towards the stack and is still rigid enough by reason of the long bearing surface or number of bearing points. The drive can be effected e.g. by means of a toothed belt, toothed rack etc.

10

It is understood that depending upon the design of the positioning conveyor the sliding plate engages underneath or through the positioning conveyor, in order to position a package on the other side in the stack.

15 It is also possible to design the at least one sliding plate to be movable in the longitudinal direction (X-direction) of the positioning conveyor, in particular if only one or a few, preferably two, sliding plates are provided. Then, they can be movable jointly or independently of one another. If they are movable independently of one another, a plurality of packages can be displaced simultaneously onto the carrier or  
20 into the stack.

Alternatively, in accordance with the number of individual pushers, it is also possible to distribute a corresponding number of sliding plates uniformly over the length of the positioning conveyor. Then, adjustability in the X-direction is not required. Each  
25 sliding plate is then preferably "allocated" to an individual pusher and is arranged with the individual pusher in a vertical plane, i.e. arranged flush one on top of the other as seen from above. The sliding plates can likewise be designed with common drives in a similar manner to the individual pushers (see above).

30 It is likewise possible to control selected individual pushers jointly, so that e.g. two to four adjacent individual pushers move one relatively large package together at the same time. Accordingly, the sliding plates can also be controlled jointly.

In order to provide a structurally simple and non-obstructive suspension, it is  
35 expedient if the arrangement of the individual pushers is fastened to a frame

extending above the positioning conveyor. The frame rests preferably on rail-like profiles and also serves as a support or suspension for the sliding plates. Therefore, the frame, together with the arrangement of the individual pushers and the sliding plates, forms a modular pusher/sliding plate unit.

5

In the case of highly complex automatic systems and procedures such as this, all manner of planning cannot prevent the occurrence of malfunctions, e.g. because a package falls over during stacking. Then, an operator is required to intervene manually. In one embodiment, in order to permit or facilitate the intervention of an operator, it is thus provided that the frame, together with the unit consisting of the pusher and sliding plates, is movable away from the stacking location, which can be effected manually or in a driven manner. For this purpose, the unit is preferably displaceable in the manner of a rail, in particular by means of a drive. Preferably, the drive is a spindle which is driven manually or by motor. It is likewise expedient if the positioning conveyor is fastened to the frame, so that the positioning conveyor is likewise "removable". This option of manually overcoming a malfunction or of manually loading increases the availability of the device.

10  
15

A shifter for the packages can be arranged between the feeding conveyor and the positioning conveyor. It can be designed as a pusher. It is possible for the pusher, together with the transfer cart, to transport the package to the desired X-position, so that the package is transported virtually "clamped" between the pusher and lateral stop of the transfer cart. Therefore, high accelerations and speeds can be achieved during positioning without the risk of packages being displaced, falling down etc.

20  
25

Therefore, in one variant the pusher (shifter) is movably suspended and driven on a rail which extends along the carrier and runs in parallel with the positioning conveyor.

However, it is also feasible for the feeding conveyor to place the packages directly onto the positioning conveyor without the interposition of a shifter. In one variant, the feeding conveyor terminates for this purpose perpendicularly with respect to the positioning conveyor and "pushes" the packages directly onto the positioning conveyor.

30

Overall, it is possible in this way to effect stacking of the carrier in a flexible manner

35



and with a high level of efficiency. In particular, a broad spectrum of different packages can be stacked continuously. For instance, in addition to the uniform packages which are not very awkward and can likewise be handled as a matter of course, packages having the most varied dimensions can be stacked consecutively  
5 onto the carrier.

The packages can be the most varied goods, such as packaged goods, goods packaged in groups, such as cardboard boxes, crates, containers, goods on trays, packing units, such as film-wrapped multipacks of plastic bottles etc., as well as  
10 individual articles of any type.

The support can be intermediate plates or carriers, such as pallets and trolleys, or similar supports for piece goods and the packaging thereof.

15 A feeding conveyor is understood to be conveyors in general and in particular roller conveyors, conveyor belts and conveyor systems. They can be loaded manually or automatically. The packages are singulated and delivered in the correct sequence for the desired packing sequence on the conveyor equipment. The correct sequence is determined arithmetically as an order is being processed. Corresponding software for  
20 this purpose is known. The special feature resides in the fact that the packages are delivered on the feeding conveyor without any auxiliary means, such as trays, containers etc.

The packages are thus delivered in singulated fashion. However, it is also possible to  
25 arrange groups of identical or very similar packed or unpacked items for collective handling. This grouping is then effected either in the region where the packages are received from the feeding conveyor by the displacement means or even when the feeding conveyor is being loaded. The particular design of the pusher as a bank makes it possible specifically for packages such as these to be transferred or  
30 positioned together.

It is also favourable if the packages are oriented before being received by the displacement means. This allows the packages to be received by the displacement means in standardised and thus simplified manner. Alternatively or in addition,  
35 corresponding optical methods for detecting the orientation of the packages and

controlling the displacement means can also be used, in order to achieve the orientation therewith. The orientation can be effected e.g. by means of the shifter. The movable stop can also be used for orienting purposes.

- 5 It is expedient if the stack on the carrier is stabilised during and/or after stacking. Therefore, the individual layers maintain their structure and the stacked carrier can be transported more securely.

10 In order to stabilise the stack after stacking (complete stack or individual layers), the stack can be stabilised together with the stacked carrier by having a film, net or the like wrapped around it. Wrapping can be performed in layers gradually during stacking or after stacking of one layer. In this case, stabilisation takes place within the actual stacking device. The already partially stacked carrier is lowered by the depth of a layer in order to adapt the level for stacking purposes. This is utilised because  
15 already formed layers of the stack can "slide downwards" and be wrapped in layers below the stacking level, while "at the top" stacking continues. This saves time. For this purpose, a film wrapping device is integrated directly into the device. This has the advantage that the carrier with a formed stack does not have to be moved separately. For instance, stabilisation can be effected each time a tier or layer has been lowered.  
20 As a result, it is possible to achieve a high level of stability in the stack even when the carriers have not actually been stacked in a completely stable manner. This also greatly expands stack-forming options in terms of the goods and selectable sequence.

25 Of course, as an alternative to the film-wrapping technique all other known stabilisation options can be used. This includes e.g. shrink-wraps, nets and other stretchable materials as well as hook-and-loop fasteners and adhesive connection means etc.

30 During actual stacking, stabilisation can be effected by means of lateral walls arranged in a U-shaped manner around the stacking location or carrier, so that stacking can be performed "against the wall". The sidewalls and the rear sidewall can be adjusted or moved vertically and/or horizontally in relation to the stacking location. Therefore, carriers etc. of a different size can be loaded and the walls can serve as a scraper in conjunction with intermediate plates.

Depending upon the packages to be stacked, it may be necessary for the purpose of protecting the packages or for increasing the stacking capability etc. to place inserts, e.g. consisting of cardboard or paperboard, between, below or above the layers. For this purpose, the flat material can be appropriately stocked and/or delivered and can  
5 be placed by means of suckers provided on the handling means.

The carriers (e.g. pallets) and also the inserts (cardboard) can be delivered and presented by means of separate conveying equipment. The carriers or inserts can be received or transferred using dedicated equipment.

10

In one embodiment, it is arranged that an intermediate plate is provided at the level of the positioning conveyor above the carrier to be loaded. The intermediate plate provides a uniform smooth surface for forming a stack and permits further stacking in spite of any change of carrier.

15

The intermediate plate is divided preferably in the middle and each part is designed to be displaceable towards the side.

In one variant, the first tier of a stack is formed on the intermediate plate, while the  
20 completely loaded carrier from the preceding stacking procedure underneath it is swapped for a new empty carrier. Therefore, the stacking procedure can be continued without interruption. If the first layer is formed and the new carrier is present, the parts are moved to the side and the first layer is transferred in this manner onto the underlying carrier, on which stacking subsequently continues.

25

In a preferred alternative, the complete stacking procedure takes place on the intermediate plate which for this purpose is designed to be height-adjustable. This has the advantage that the transfer to the carrier only takes place after stacking and the carrier does not have to be "swapped". As a result, the total throughput rate of the  
30 device is increased. Moreover, the optionally provided stretch film-wrapping can be effected more easily.

When the intermediate plate is moved apart or opened, the lateral stabilisation walls serve as a scraper, i.e. the intermediate plate moves laterally below the lower edges  
35 of the walls.

There is a greater requirement for the stacked packages to be provided in so-called trolleys or rolling containers. They can be loaded easily into trucks and unloaded in situ and moved, as they comprise rollers. Moreover, they comprise sidewalls which  
5 permit stable stacking and effective stabilisation by means of stretch film, so that transportation is likewise secure. However, these characteristics cause problems during automatic stacking.

In accordance with the invention, it has been recognised that automatic stacking is  
10 possible in a reliable manner if the sidewalls of the trolley are held by a spreading device at least perpendicularly or even bent open in a slightly inclined manner outwards. The sidewalls specifically have the characteristic of moving inwardly towards one another.

15 It has also been found that stacking of trolleys can be facilitated if for this purpose a separate and optionally height-adjustable intermediate plate is provided which is arranged on the side of the stacking location or the carrier remote from the positioning conveyor or can be introduced from this side into the trolley.

20 Therefore, the device in accordance with the invention can be used for stacking pallets etc. or trolleys alternately according to requirement.

The rear sidewall can serve as a scraper when the completely stacked stack is transferred to the trolley by retracting the further intermediate plate. In one  
25 embodiment, the rear sidewall is also height-adjustable and/or movable in the direction of the positioning conveyor, so that trolleys of a different size can be used.

This preferably also serves as an attachment location for the spreading device.

30 The spreading device consists preferably of two pins which are arranged at the same height in the region of the expected sidewalls of the trolley, protrude from the sidewall forwardly into the trolley space and can be displaced laterally outwards for spreading purposes. For this purpose, the pins are preferably arranged in each case on a vertically oriented rotary disk in the rear sidewall.

For ease of transportation and handling within the system, the trolleys are moved on transport pallets which can be handled in the same manner as normal pallets.

Further details of the invention will be apparent from the description hereinafter of  
5 exemplified embodiments with reference to the drawing, in which

- Figure 1 shows a schematic perspective view from one side of a device for the automatic layered stacking of pallets;
- Figure 2 shows a schematic perspective view of the device of figure 1 from a  
10 different angle of view;
- Figure 3 shows a schematic perspective view of the displacement means of the device of figure 1 as a package is received;
- Figure 4 shows a schematic perspective view of the displacement means of the device of figure 1 as the package is transported in the X-direction;
- 15 Figure 5 shows a schematic perspective view of the displacement means of the device of figure 1 as transportation of the package in the Z-direction commences;
- Figure 6 shows a schematic perspective view of the displacement means of the device of figure 1 as transportation of the package in the Z-direction  
20 commences, from a different angle of view;
- Figure 7 shows a schematic perspective view of the displacement means of the device of figure 1 during further transportation of the package in the Z-direction;
- Figure 8 shows a schematic perspective view of the displacement means of the device of figure 1 as transportation of the package in the Z-direction  
25 ends;
- Figure 9 shows a schematic perspective view of the displacement means of the device of figure 1 after transportation of the package in the Z-direction has ended;
- 30 Figure 10 shows an enlarged detailed view of the common drive of the individual pushers;
- Figure 11 shows an enlarged detailed view of the transfer cart;
- Figure 12 shows a schematic perspective and enlarged view of the device of figure 1 in the region of the stacking location as the stacking procedure  
35 ends;

- Figure 13 shows a schematic perspective and enlarged view of the device of figure 1 in the region of the stacking location as the stack is transferred from the intermediate plate onto a pallet;
- Figure 14 shows a schematic perspective and enlarged view of the device of figure 1 in the region of the stacking location as the stack is lowered;
- Figure 15 shows a schematic perspective and enlarged view of the device of figure 1 in the region of the stacking location as the stack is wrapped in film and transported away;
- Figure 16 shows a schematic perspective view of the device during automatic layered stacking of the trolley in the region of the stacking location during stacking;
- Figure 17 shows a schematic perspective view of the device of figure 16 at a different angle of view, wherein the rear stabilisation wall is omitted for improved clarity;
- Figure 18 shows an enlarged view of the device of figure 16 during spreading of the trolley sidewalls, and
- Figure 19 shows a detailed view of the mechanism for spreading the trolley sidewalls.
- Figures 1 to 19 show a device, which is designated as a whole by the reference numeral 1, for automatic layered stacking of pallets P with packages W of different dimensions in a predetermined spatial arrangement. This is a device for "mixed-case" palletising. Naturally, the device 1 can also be used for palletising merely similar packages W.
- The device 1 comprises a roller conveyor 2 as a feeding conveyor which provides the singulated packages W in a computer-aided predetermined sequence from a warehouse, not shown.
- Arranged at the end of the roller conveyor 2 is a shifter 31 which is designed as a pusher 3 and shifts the packages W by 90° and places them onto the subsequent positioning conveyor. The packages W are likewise angularly oriented, so that they are oriented on the positioning conveyor 4 insofar as their outer shape allows.
- The positioning conveyor 4 is designed as a transfer cart. It serves to position the

packages W in the X-direction, in order to adopt this coordinate of the subsequent position in the stack.

5 The positioning conveyor or the transfer cart or more precisely the transport surface thereof is arranged horizontally at the same level and along a side of the location 6 for stack formation. The carrier P (pallet) or trolley (R) which is to be loaded will typically be located here.

10 At the level of the transport surface above the carrier P to be loaded, an intermediate plate 8 is provided in the location 6. The intermediate plate 8 is divided in the middle and each part 8A, B is designed to be displaceable towards the side (in the X-direction) such that a stack is formed on the intermediate plate 8, whereas the completely loaded carrier P from the preceding stacking procedure underneath it is swapped for a new empty carrier P. Therefore, the stacking procedure can be  
15 continued without interruption.

In order to feed empty pallets or remove stacked pallets, a corresponding roller conveyor 9 is provided below the stacking location 6.

20 The respective pallet P is received from the roller conveyor by a lifting and lowering unit 10 for lifting and lowering the carrier P in the Y-direction and is moved upwards to the stacking location 6. The lifting and lowering unit 10 is also responsible *per se* for adapting the level during stacking, i.e. it performs a lifting or a lowering movement as necessary during stacking of a package W and also performs adaptation of layer  
25 balancing at the beginning of a new layer.

The respective package W is thus pushed in the Z-direction by the transfer cart 4 onto the desired position in the stack laterally into the location 6 onto the intermediate plate 8.

30 For the purpose of this displacement of the packages W to the predetermined position in the stack S, the device comprises sliding plates 11 and a pusher bank 12, i.e. in each case a plurality of individual sliding plates 13 and individual pushers 14 arranged next to one another horizontally and along the side of the stacking location 6 or the  
35 pallet P.

The sliding plates 13 engage through between the frame of the transfer cart 4 and receive the package W pushed by the pusher 14. Subsequently, the pusher and the sliding plate travel together to the desired position and the sliding plate 13 is retracted, whereas the pusher 14 remains stationary to retain the package W. Therefore, the package W is positioned. The sliding plates 13 become flat at the front, so that positioning can be effected as precisely as possible.

The sliding plates 13 are each designed as flat, strip-like plates which are movable horizontally and along the side of the stacking location 6 and transversely thereto and which become thinner in the direction of the stacking location 6.

The sliding plates 13 are suspended on the side of the transfer cart 4 opposite the carrier and are arranged in parallel and next to one another. They are each movable back and forth in the manner of a carriage on a linear axle 16 oriented in the Z-direction. The drive is effected for each axle by means of an electric motor 16E and a toothed belt (not shown) which is arranged on the linear axle and into which the carriage or the sliding plate 13 is hooked.

Therefore, the sliding plates 13 form as it were an optional widening of the transfer cart 4 into the stacking location 6.

The pushers 14 are arranged flush with one another horizontally and along the side of the stacking location 6 or the carrier P and are designed to be movable independently of one another. They are arranged on the side of the positioning conveyor opposite the carrier or are in the rest position at this location, in order to extend over the transfer cart 4 for the purpose of pushing packages.

The pushers, like the sliding plates, are also arranged over the entire length of the stacking location 6 or the pallet P and are fastened to a frame 17 mounted above the positioning conveyor. At this location, they are each movable back and forth in the manner of a carriage on a linear axle 18 oriented in the Z-direction. The drive is effected for each axle by means of an electric motor 18E and a toothed belt (not shown) which is arranged on the linear axle and into which the carriage or the pushers 14 is/are hooked.



The pushers 14 extend from the respective linear axle downwards to a height only just above the surface of the transfer cart 4 and comprise at the end at that location a flatly enlarged base for handling the packages W more effectively and more safely.

5

Provided below the stacking location 6 is a unit 19 for wrapping the formed stack S in a film.

Wrapping is effected in layers gradually during stacking or after stacking of a layer.

10 The carrier P comprising the already formed layers of the stack S is lowered gradually downwards by the lifting and lowering unit 10 and thus travels through the annularly formed unit 19 in order to be wrapped.

15 If the entire stack S is completed, the stack S is transferred to the pallet P and is moved downwards and transported away via the roller conveyor 9.

At the same time, the intermediate plate 8 is closed and stacking continues thereon to form the next stack of the next order.

20 Overall, in order to automatically stack packages W onto a pallet P in a predetermined spatial arrangement to form a stack S, the sequence and spatial position of the packages W on the pallet P are determined in a computer-aided manner in order to create a stack S using the order forming the basis thereof.

25 The packages W are then acquired individually without auxiliary means (trays etc.) from a warehouse etc. in a predetermined sequence, which is required for this purpose, by means of the feeding conveyor 2. The packages W to be loaded are then shifted from the feeding conveyor 2 by the shifter 3 onto the transfer cart 4.

30 By means of this and the pusher bank 12 and sliding plates 13, the respective package W is transported to the predetermined spatial position on the pallet P or the stacking location 6 or intermediate plate 8 in the stack being formed.

35 Depending upon requirement, the pallet P is lowered or raised in the Y-direction by the corresponding unit 10.

It is apparent from figure 10 that the individual pushers of the pusher bank do not each comprise dedicated drives.

5 The individual pushers comprise two common drives 21, 22 which can be optionally coupled to a specific individual pusher in order to drive same. For this purpose, the drives 21, 22 are movable in the X-direction on the frame 17 above the individual pushers by means of a cross member 21T, 22T and can be coupled to the drive carriage 23 of the individual pushers 14.

10

The drive 21, 22 comprises in each case an actual drive block 24, 25 which is movable in the Z-direction in a similar manner to the above embodiment of the pushers. In order to drive the respective individual pusher 14, the drive block 24, 25 comprises a coupling lug 26 which points in the direction of the drive carriages 23 and  
15 engages into a groove 27, which extends transversely with respect to the X-direction, in the drive carriage 23.

In order to drive a specific individual pusher, the drive 21 or 22, depending upon the individual pusher, is moved by means of the cross member in such a manner that the  
20 corresponding coupling lug 26 engages into the groove 27 of the respective drive carriage 23. Subsequently, the drive block 24 or 25 is moved and entrains the drive carriage 23 or the individual pusher 14 in the Z-direction.

The individual pushers are thus suspended from a frame, on which they are movable  
25 in the Z-direction towards (or away from) the stack. For this purpose, they are approached by a carriage or cross member which is arranged above and extends transversely thereto, i.e. in the X-direction and supports the drive, wherein a coupling or entraining element establishes the operative connection between the drive and the individual pusher.

30

It is also apparent that the entraining element (coupling lug 26) is suspended in the manner of a sheet or strip from the drive or its travel cross member 21T, 22T and engages into a groove 27, which is open at the top, on the drive carriage of the adjacent individual pusher(s) 14, for which reason the entraining element 26 is of a  
35 corresponding width, so that it can engage by means of corresponding positioning

either into the groove 27 of an individual pusher or into the two grooves 27 of adjacent individual pushers 14.

5 Only two sliding plates 13 are used which are then movable in the X-direction along the stacking location 6 by means of a drive 28, 29, so that the respective sliding plate can be positioned corresponding to an individual pusher. For this purpose, the respective linear axle of the sliding plate is designed to be movable in a similar manner to a cross member. An arrangement corresponding to the individual pusher bank without movement of the sliding plates in the X-direction would also be feasible.

10

It is also possible to control both sliding plates together, so that a package W is supported on both sliding plates at the same time. Obviously, this can be combined with a corresponding control and use of e.g. two individual pushers.

15 The transfer cart 4 receives individual packages W from the feeding conveyor 2. For this purpose, the shifter 31 pushes the packages from the feeding conveyor 2 onto the transfer cart 4.

20 The transfer cart 4 comprises a movable stop 32 on the remote side, in order to prevent the packages W from falling off the actual transport surface 35 and to permit precise positioning. In order to ensure that the package W does not fall off when the transfer cart 4 is accelerated, the shifter 31 is moved in synchronism with the transfer cart 4 in the X-direction, so that the respective package is transported on the transfer cart 4 clamped between the stop 32 and the shifter 31.

25

For movement in the X-direction, rails 33 are provided, on which the transfer cart 4 is movable between the stacking location 6 and the pusher/sliding plate unit. Arranged above and in parallel therewith is a corresponding rail 34 for the synchronous movement of the shifter 31. The rails 33, 34 are similarly fastened to the frame 17.

30

The transfer cart 4 is designed having a C-shaped frame 36, so that the at least one sliding plate can then engage through between the limbs of the "C", so as to prevent any mutual hindrance.

35 The actual carrier surface 35 for the package is thus fastened only on one side to the

travelling mechanism of the transfer cart 4 and protrudes at this location.

The stop 32 is movable, preferably foldable or pivotable, away from the stop position, so that after "transfer" of the package to the sliding plate has been effected (cf. 5 above), the transfer cart is already able to "fetch" the next package.

For this purpose, the stop 32 can preferably be pivoted about an axis from the stop position to a release position. This embodiment does not require much space and also does not "collide" with the sliding plates. The stop comprises two stop wings 10 which are pivotable in opposite directions, in order to provide a broad stop or surface.

This also renders it possible that once the "transfer" of the package W to the sliding plate has been effected, the transfer cart already travels back to receive the next package from the feeding conveyor 2 before the stacking procedure is completed. 15

The transfer cart 4 thus travels with the package W, which is clamped by the folded-up stop 32 and shifter 31, to the respective pre-calculated X-position on the rails 33.

At the same time, the cross members 21T, 22T for the individual pushers travel from 20 the left and right in the X-direction to the required position in order to interact with the drive carriages 27 of the individual pushers 14, wherein the entraining element 26 engages into the respective groove 27. The sliding plates 13 are likewise positioned in the X-direction.

Then, as described, pushing from the transfer cart 4 (positioning conveyor) is effected 25 by the individual pushers, two pushers in this case, onto the sliding plates, also two in this case, for which reason the drive block 24, 25 travels along the cross member in the Z-direction and in this way entrains the individual pusher 14 in each case. Accordingly, the two sliding plates 13 are extended in the Z-direction, in order to 30 receive the package W from the transfer cart 4, wherein they can "engage through" the transfer cart 4 by reason of the C-shaped frame 36.

As soon as the package W rests completely on the sliding plates, the stop 32 is folded 35 down and the transfer cart 4 can travel back for the purpose of receiving.

The stop 32 is formed by means of two stop disks 37A, B which are rotatable anticlockwise and clockwise respectively. The stop disk 37A is pivoted or folded down in an anticlockwise direction and the stop disk 37B is pivoted or folded down in a clockwise direction from the upright position bounding the package W, so that the transfer cart 4 is free.

Also illustrated is a manually operated crank K which drives the mechanism in order to permit or facilitate manual intervention, for which reason the frame 17 (together with the unit consisting of the pusher, sliding plates and positioning conveyor etc.) is moved away from the stacking location 6.

The intermediate plate 8 serves to form not only the first tier of the stack S but also the entire stack S. The stack is only transferred completely to the waiting pallet P after it has been completed, wherein the lateral walls 41 serve as a scraper.

In order to ensure that this works, the intermediate plate 8 or the parts 8A, B thereof is/are suspended in a height-adjustable manner from a lifting frame 40, so that it can be lowered in each case downwards after completion of one tier, so that the stack level is located at the height of the positioning conveyor.

If the stack S is completed, the parts 8A, B of the intermediate plate 8 are moved towards the side below the edge of the lateral walls 41 (in the X-direction), wherein the packages or the stack remains in the stacking location 6 and comes to rest on the waiting pallet P after complete removal of the intermediate plate 8.

The pallet P with the stack S loaded thereon is lowered further and (as above) passes through a wrapping unit 19 to be wrapped in stretch film for stabilisation (cf. figures 21 and 22).

At the same time, the intermediate plate 8 has then been closed and a new stack-forming procedure can be commenced.

Subsequently, the pallet comprising the stack is transferred or unloaded by the fork-like carrier 42 of the lifting and lowering unit 10 onto a roller conveyor 9 to be transported away. The lifting and lowering unit 10 corresponds substantially to the

one previously described, but in this case is a single-beam lifter.

Subsequently, a new empty pallet for the new stack is received and is lifted to the waiting position below the intermediate plate.

5

Figures 16 to 19 show a schematic perspective view of the previously discussed device for automatic layered stacking, wherein in this case a trolley R is arranged in the region of the stacking location 6 during stacking.

10 The device 1 is suitable not only for loading pallets P but also for loading trolleys R.

For this purpose, the trolleys R are fed or transported away by the same conveyor 9 as the pallets. For this purpose, the trolleys R are arranged on carrier pallets 43 (cf. figure 17) which can be handled in the same way as normal pallets.

15

The trolleys R are likewise moved by the lifting and lowering unit 10 into the stacking location 6 from below.

20 In order to spread the sidewalls RS of the trolley R apart, a spreading device 44 is provided which, during stacking, holds the sidewalls RS at least perpendicularly or even bent open in a slightly inclined manner outwards.

The sidewalls RS specifically have the characteristic of moving inwardly towards one another.

25

Since the sidewalls RS of the trolley R correspond with the parts 8A, B of the intermediate plate and the use thereof is therefore not possible, a separate and height-adjustable intermediate plate 45 arranged on the side of stacking location 6 remote from the positioning conveyor 2 is provided for the stacking of trolleys R.

30

After the sidewalls RS have been spread, the intermediate plate is introduced from this side in the manner of a carriage into the trolley R in the Z-direction by means of a drive 51. For the purpose of height-adjustment, the intermediate plate 45 is suspended from a lifting frame 50 in a similar manner to the intermediate plate 8.

35

Subsequently, the stack S is formed, as previously, by placing the packages W on the intermediate plate 45.

When the completely stacked stack is transferred to the trolley R by retracting the  
5 further intermediate plate 45, the rear sidewall 46 (which in figure 17 has been omitted  
for improved clarity) serves as a scraper. The rear sidewall 46 is also height-adjustable  
so as to "join in" with the lifting or lowering of the intermediate plate 45, and is  
movable in the direction of the positioning conveyor 2 or stacking location 6 (Z-  
direction), so that trolleys of different sizes can be used.

10

The rear sidewall 46 also serves as an attachment location for the spreading device  
44.

The spreading device 44 consists of two pins 47 which are arranged at the same  
15 height in the region of the expected sidewalls of the trolley R, protrude from the  
sidewall forwardly into the trolley space and can be displaced laterally outwards for  
spreading purposes. For this purpose, the pins 47 are arranged in each case on a  
vertically oriented rotary disk 48 driven by a common drive 49 by means of a rotating  
cable. The drive is arranged on the rear wall of the rear sidewall 46 (cf. figures 18 and  
20 19).

As the trolley is introduced, the pins 47 are thus positioned on the inside. After the  
trolley has been introduced, the pins are displaced outwards by a rotation of the rotary  
disks 48 and thus spread the sidewalls RS.

25

If the stacking procedure is completed, the pins 47 are then moved inwards and the  
intermediate plate 45 is retracted at the rear sidewall 46 serving as a scraper, so that  
the stack S of the packages W comes to lie on the trolley R.

30 Subsequently, the stack is moved by means of the lifting and lowering unit 10 through  
the film-wrapping unit 19 and finally on the roller conveyor 9 to be transported away.

The procedure can then start anew.

**Claims**

1. Device for automatically stacking packages on a support in a predetermined spatial arrangement to form a stack, comprising
- 5 - at least one feeding conveyor which provides the singulated packages (W) in a predetermined sequence;
- a lifting and lowering unit for lifting and lowering a support (P, 8), which is arranged in a stacking location (6), in the Y-direction;
- displacement means which adjoin an output end of the feeding conveyor and  
10 receive packages (W) from the feeding conveyor (2) and transport same to the predetermined position in the stack (S);
- wherein the displacement means comprise:
- a positioning conveyor (4) which adjoins the output end of the feeding conveyor and is arranged horizontally and along a side of the stacking  
15 location (6), in order to position the packages (W) in the X-direction,
- at least one sliding plate (13) and a pusher (14), in order to transport the packages (W) from the positioning conveyor in the Z-direction to the predetermined position in the stack (S),
- wherein the at least one sliding plate is designed as a flat, strip-like plate which is  
20 movable horizontally and along the side of the stacking location (6) and transversely thereto, in order to receive the packages (W) from the positioning conveyor at the X-direction position when the packages (W) are pushed by the pusher and to place same on the support (P, 8, 45) or in the stack (S) in the Z-direction, characterised in that the positioning conveyor is designed as a transfer cart.
- 25
2. Device as claimed in claim 1, characterised in that rails for the transfer cart are arranged in the X-direction along the stacking location or the support.
3. Device as claimed in claim 1 or 2, characterised in that the transfer cart is  
30 designed having a C-shaped frame.
4. Device as claimed in any one of claims 1 to 3, characterised in that the transfer cart comprises a stop on the side remote from the feeding conveyor in the X-direction.



5. Device as claimed in claim 4, characterised in that the stop is designed to be movable away from a stop position.
- 5 6. Device as claimed in claim 5, characterised in that the stop can be pivoted about an axis from the stop position to a release position.
7. Device as claimed in any one of claims 4 to 6, characterised in that the stop comprises two stop wings which are pivotable in opposite directions.
- 10 8. Device as claimed in any one of claims 1 to 7, characterised in that the positioning conveyor (4) is fastened to a frame (17).
9. Device as claimed in claim 8, characterised in that the frame (17) is designed to  
15 be movable.

Fig. 1

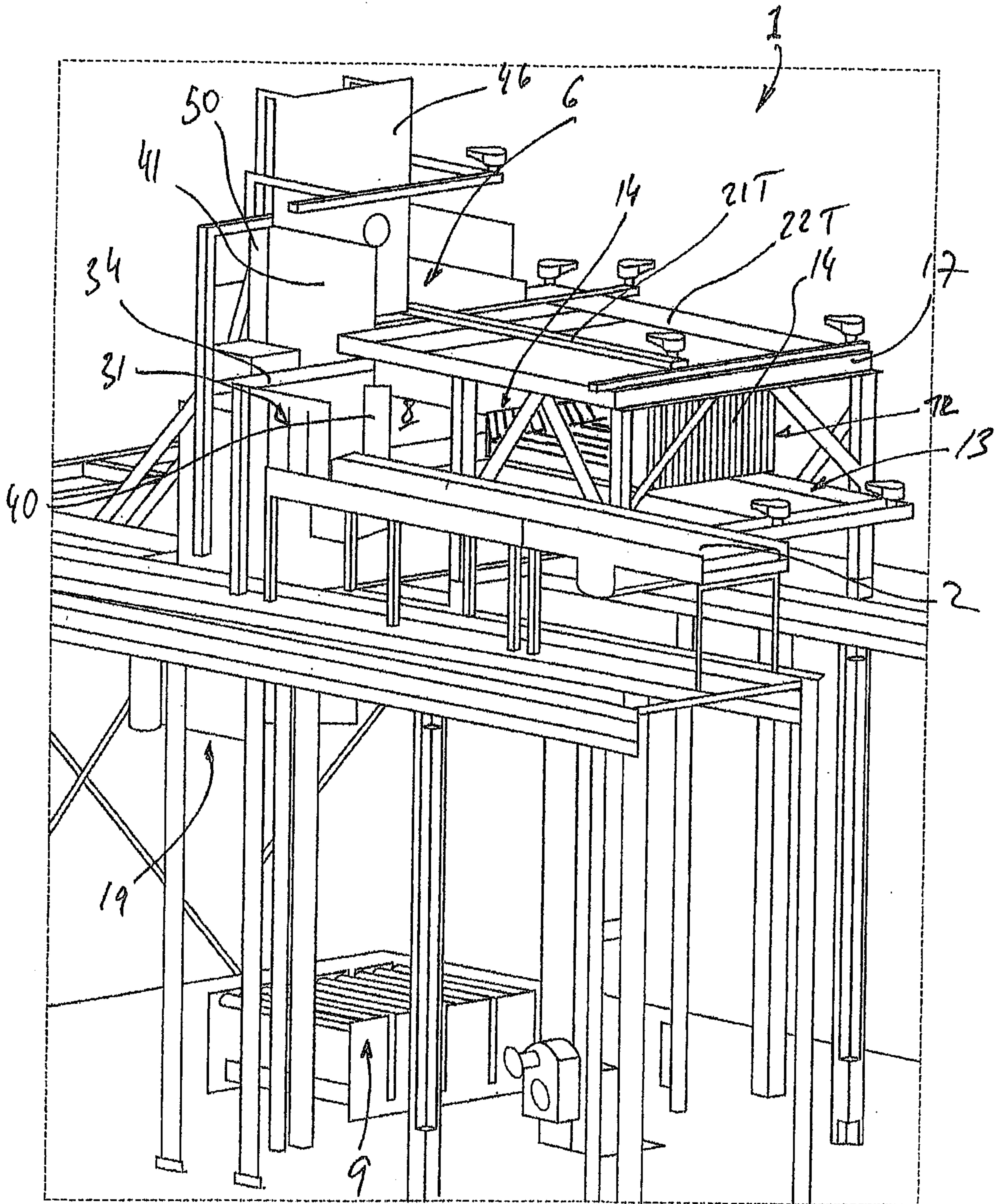

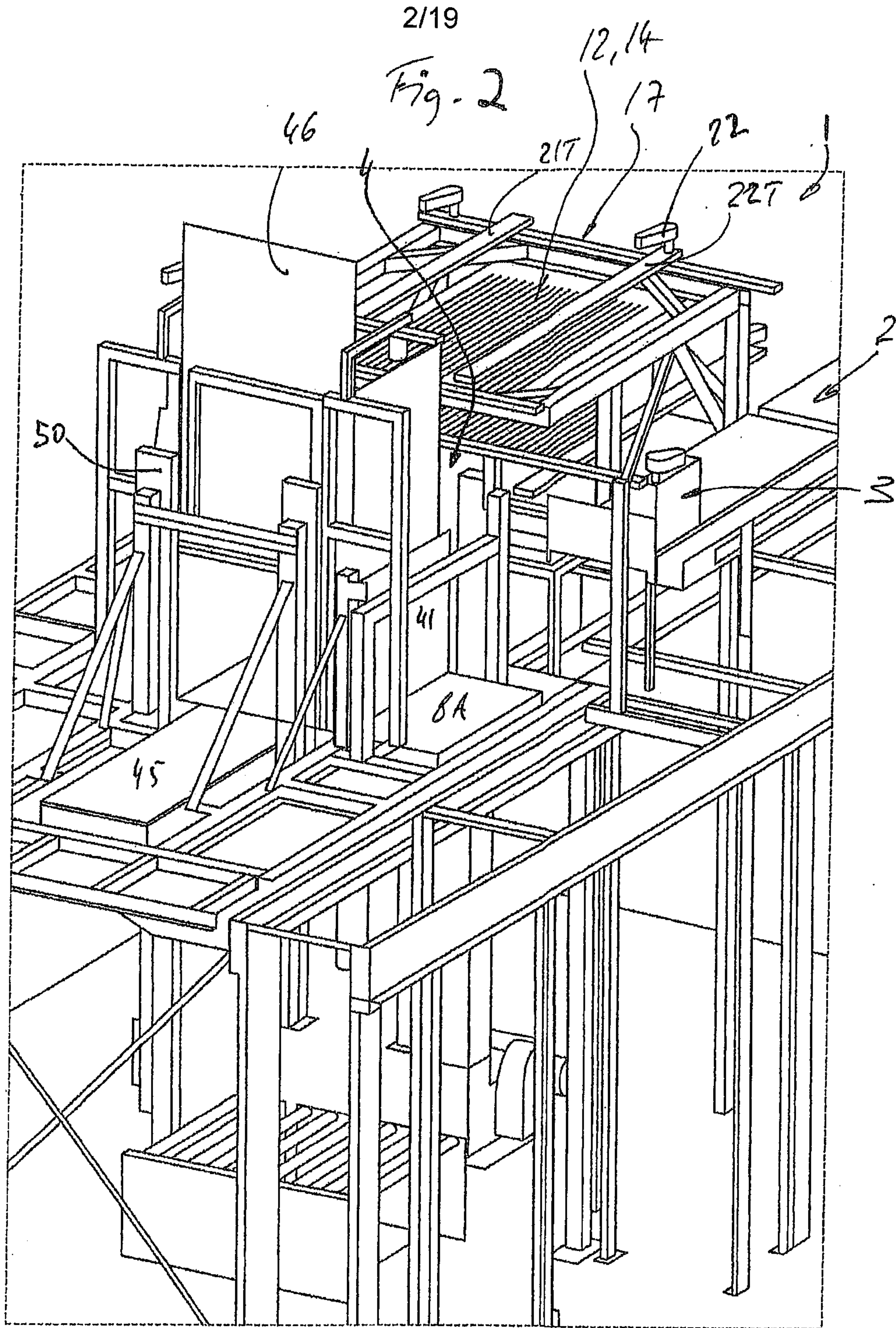

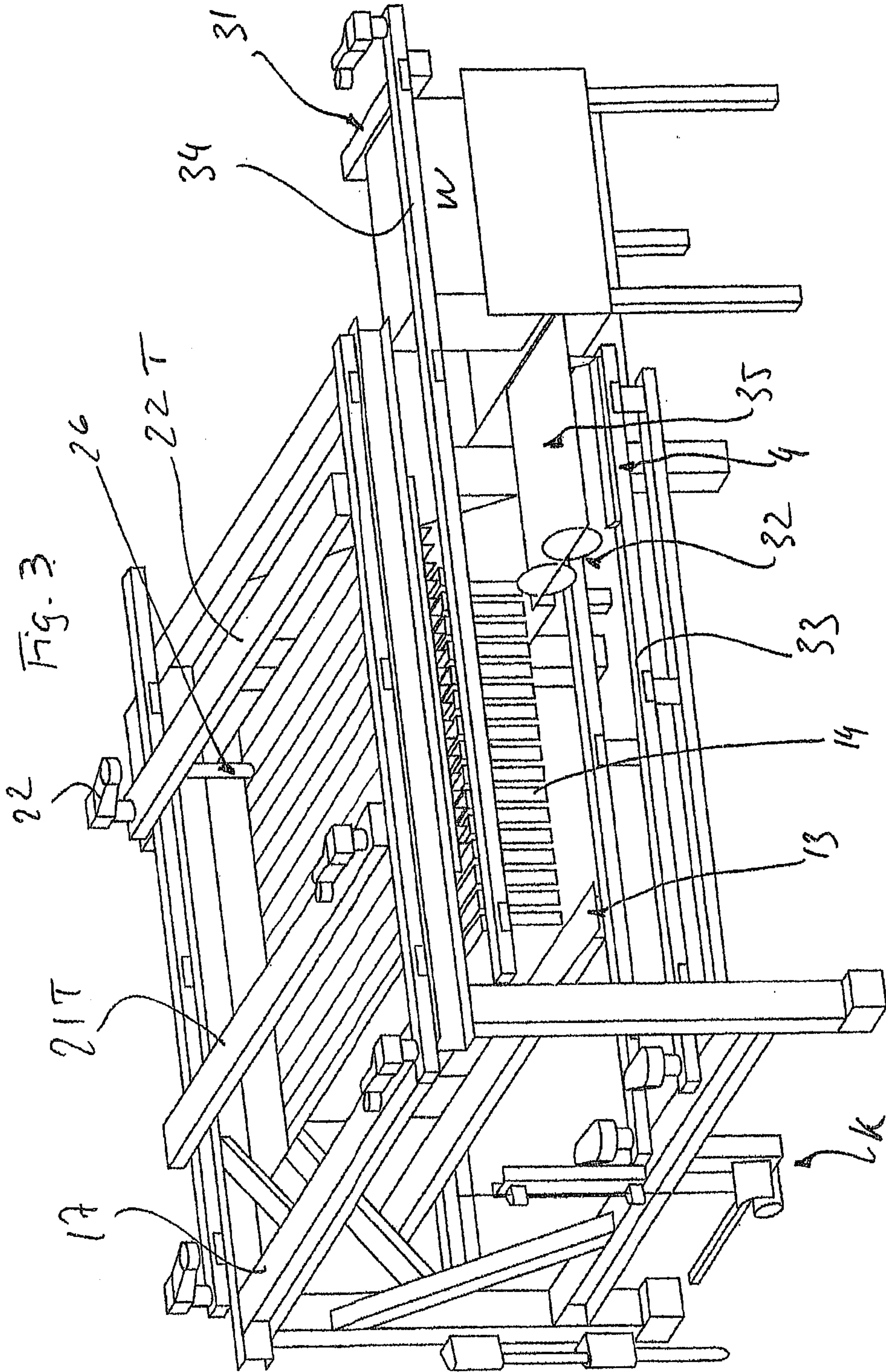

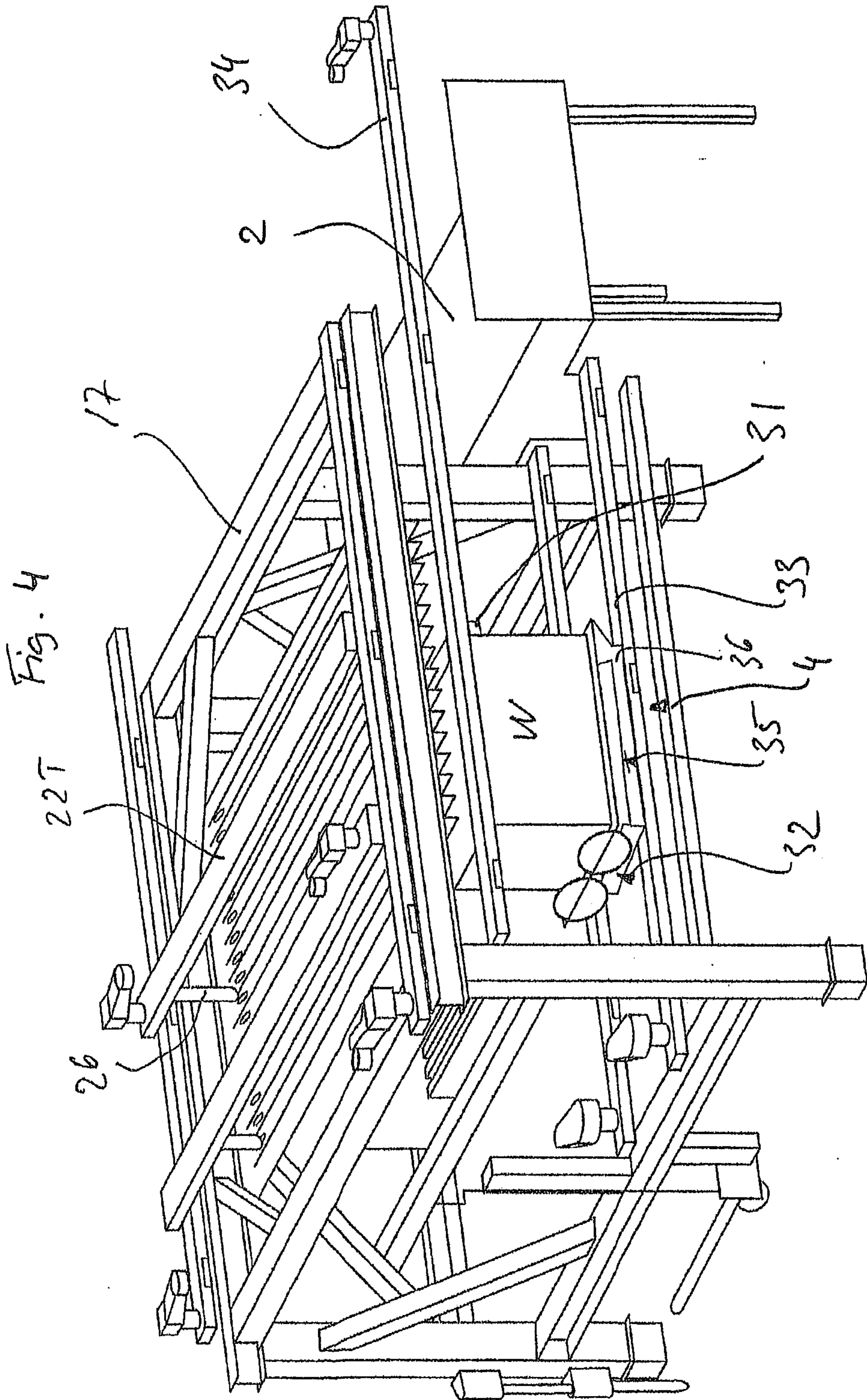

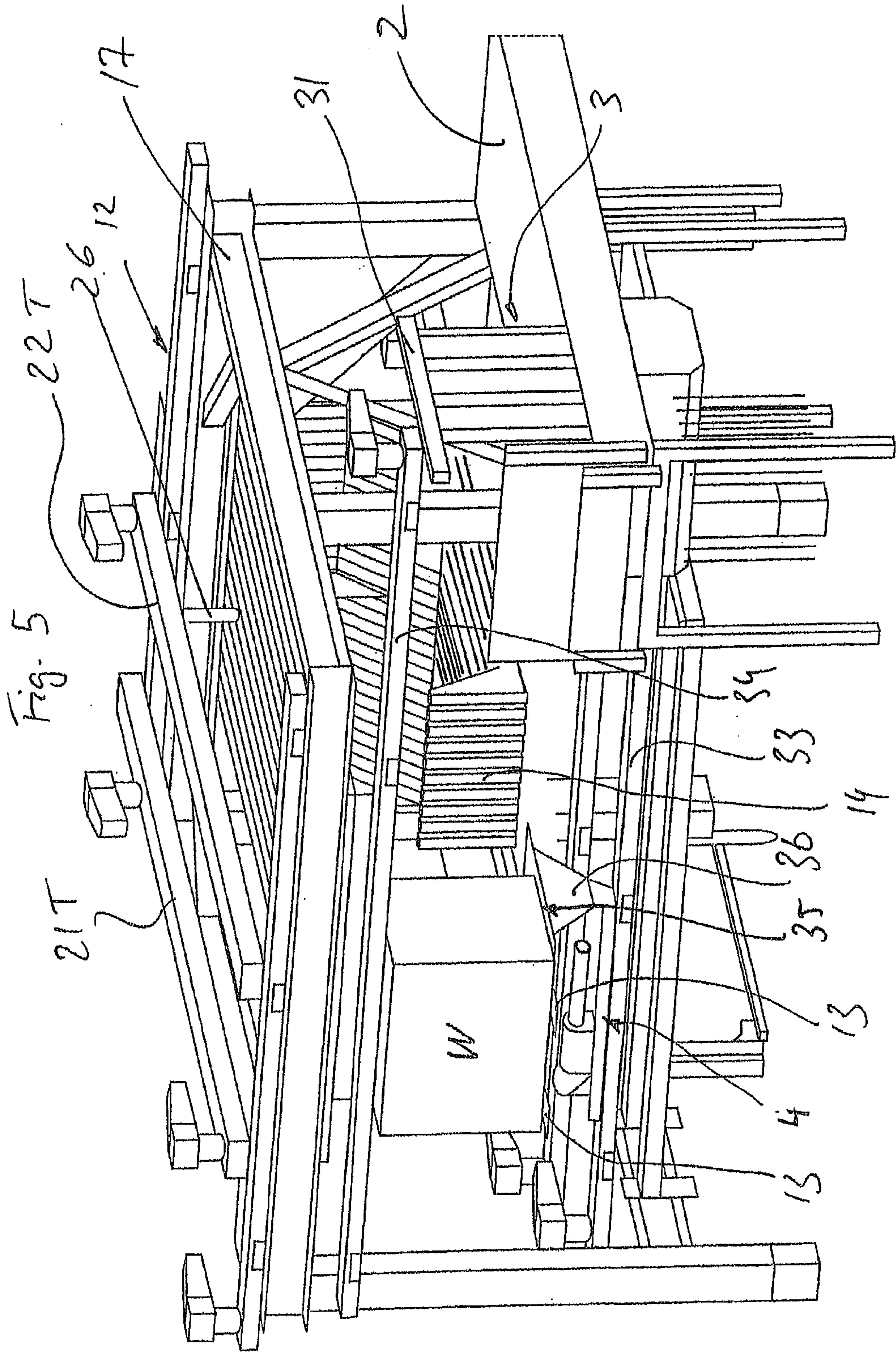

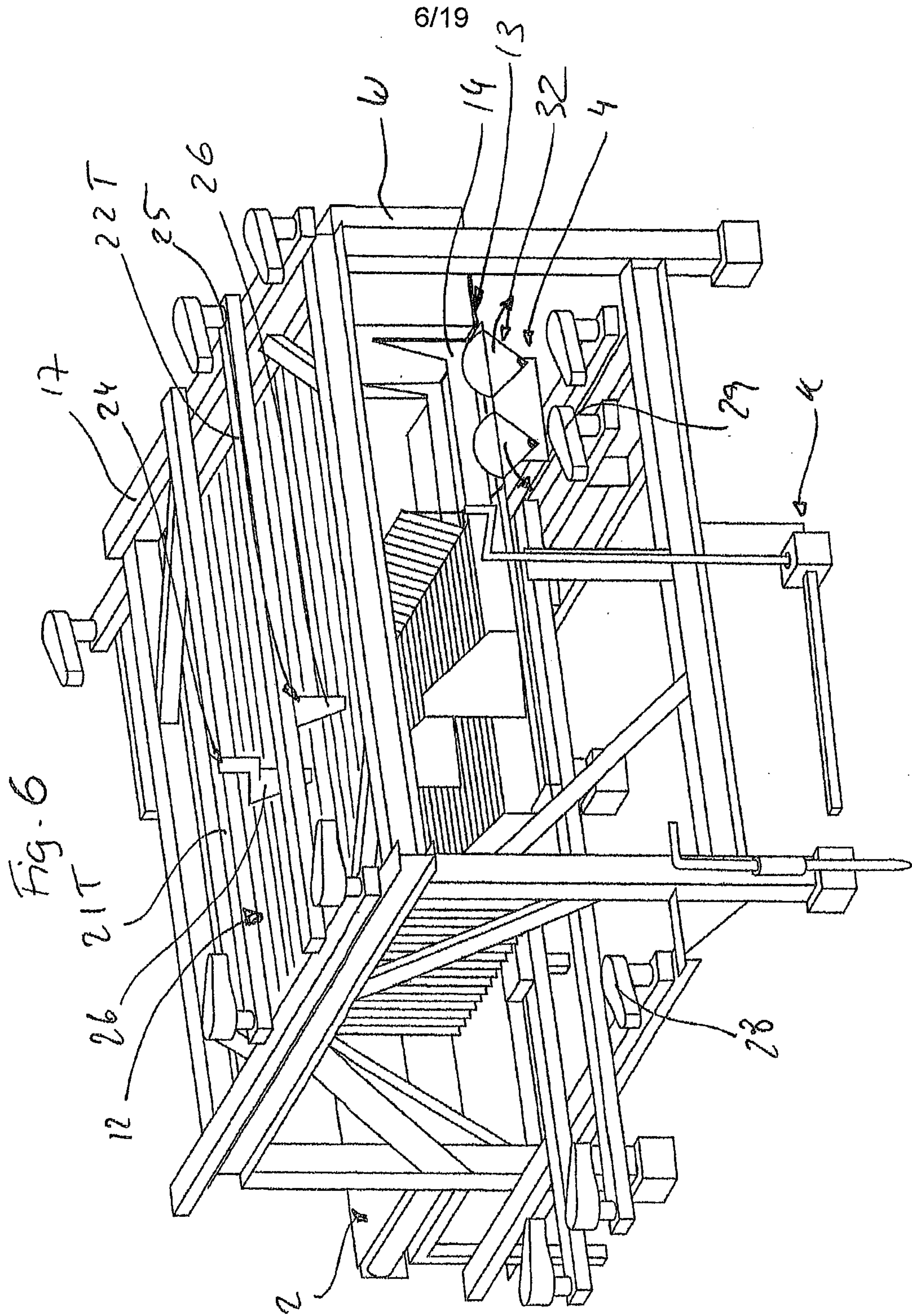
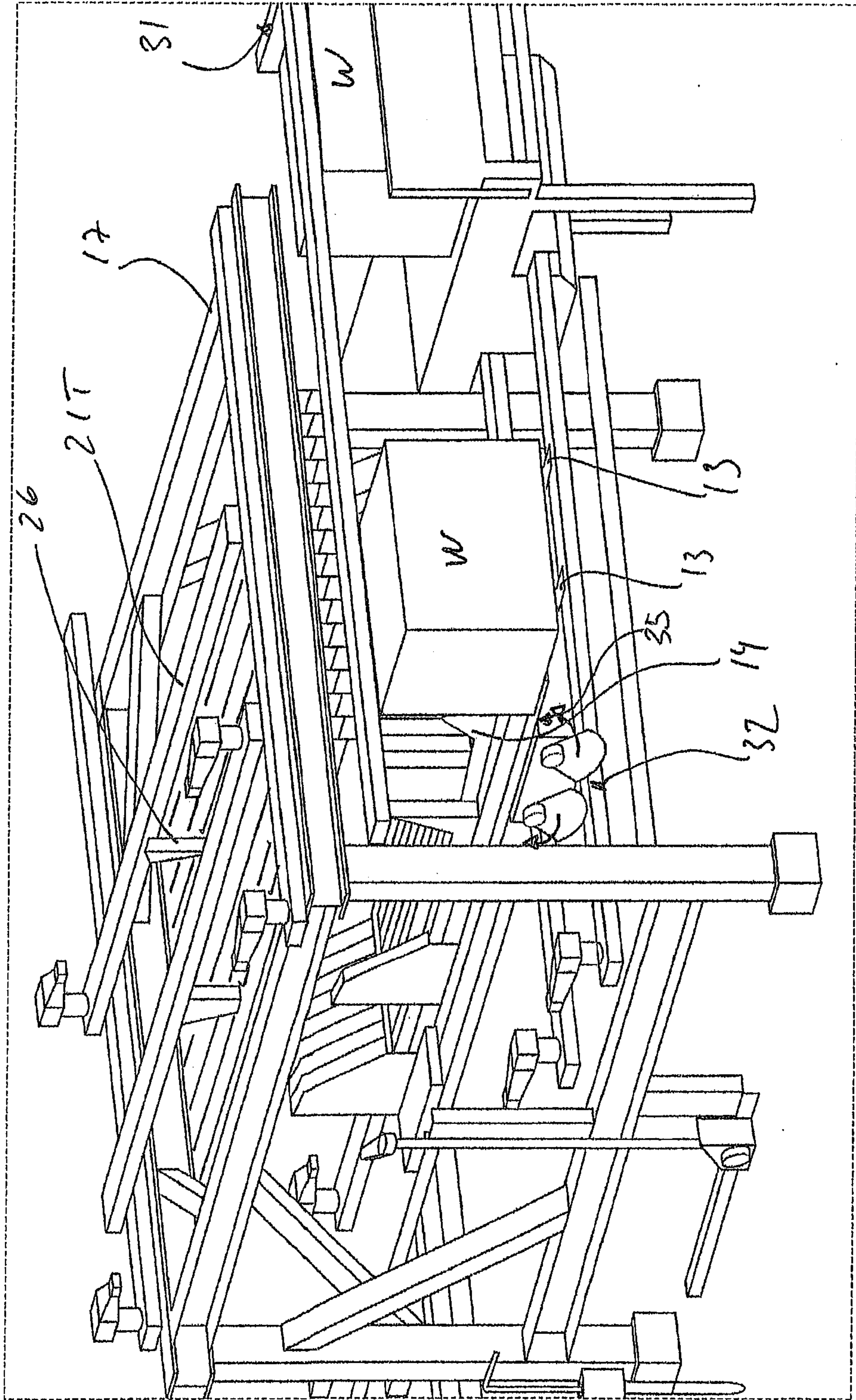
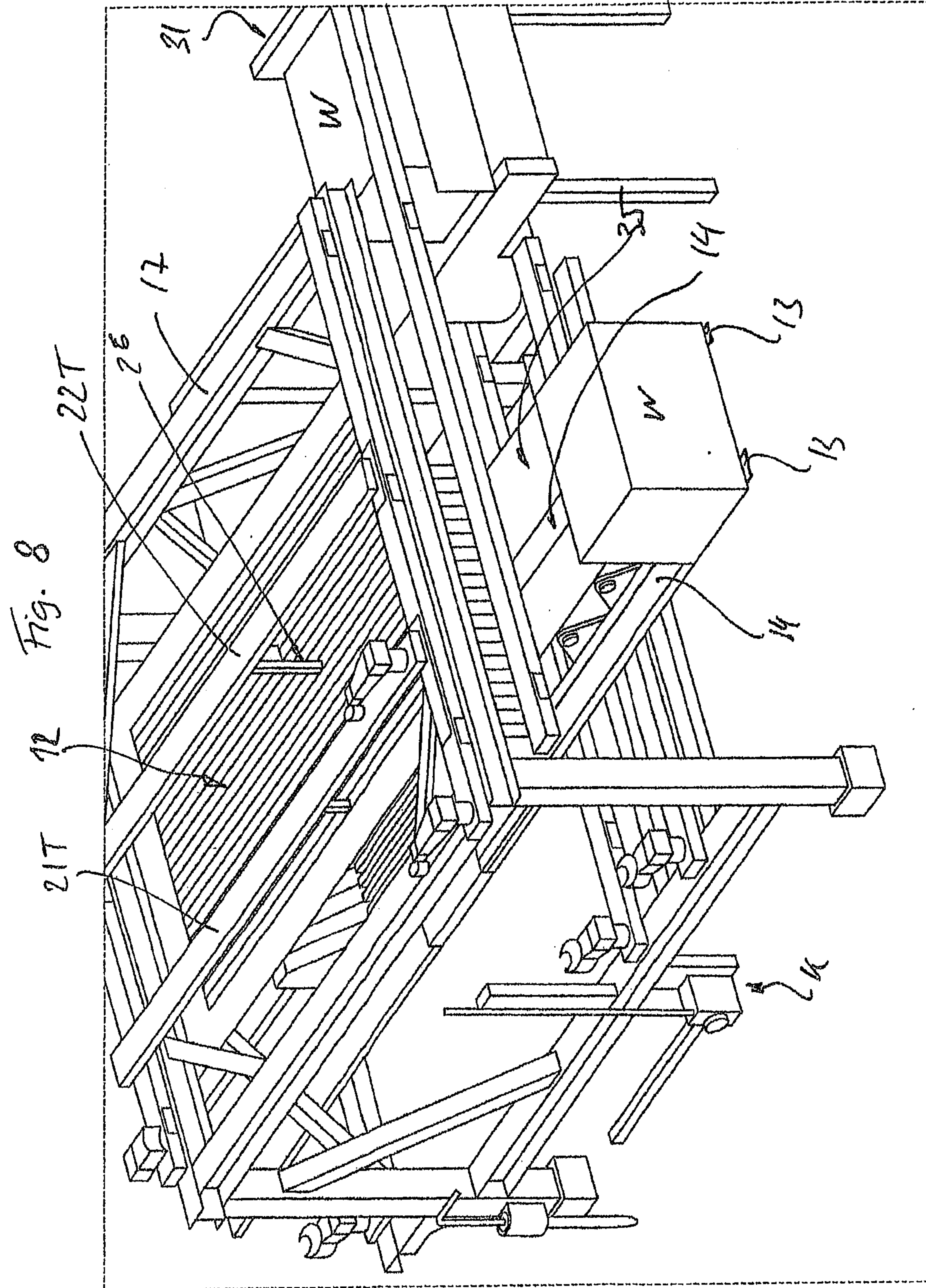
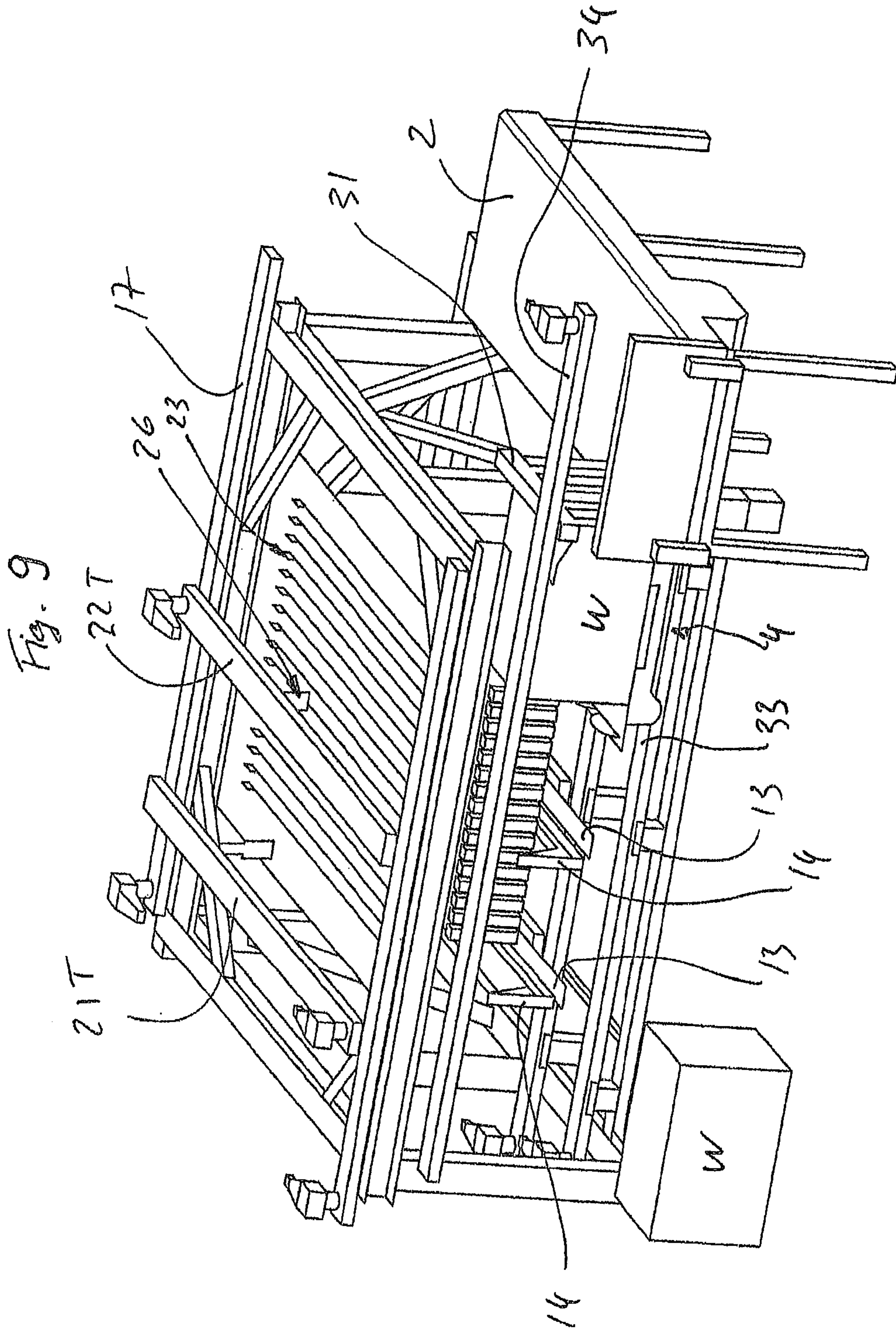

Fig. 7









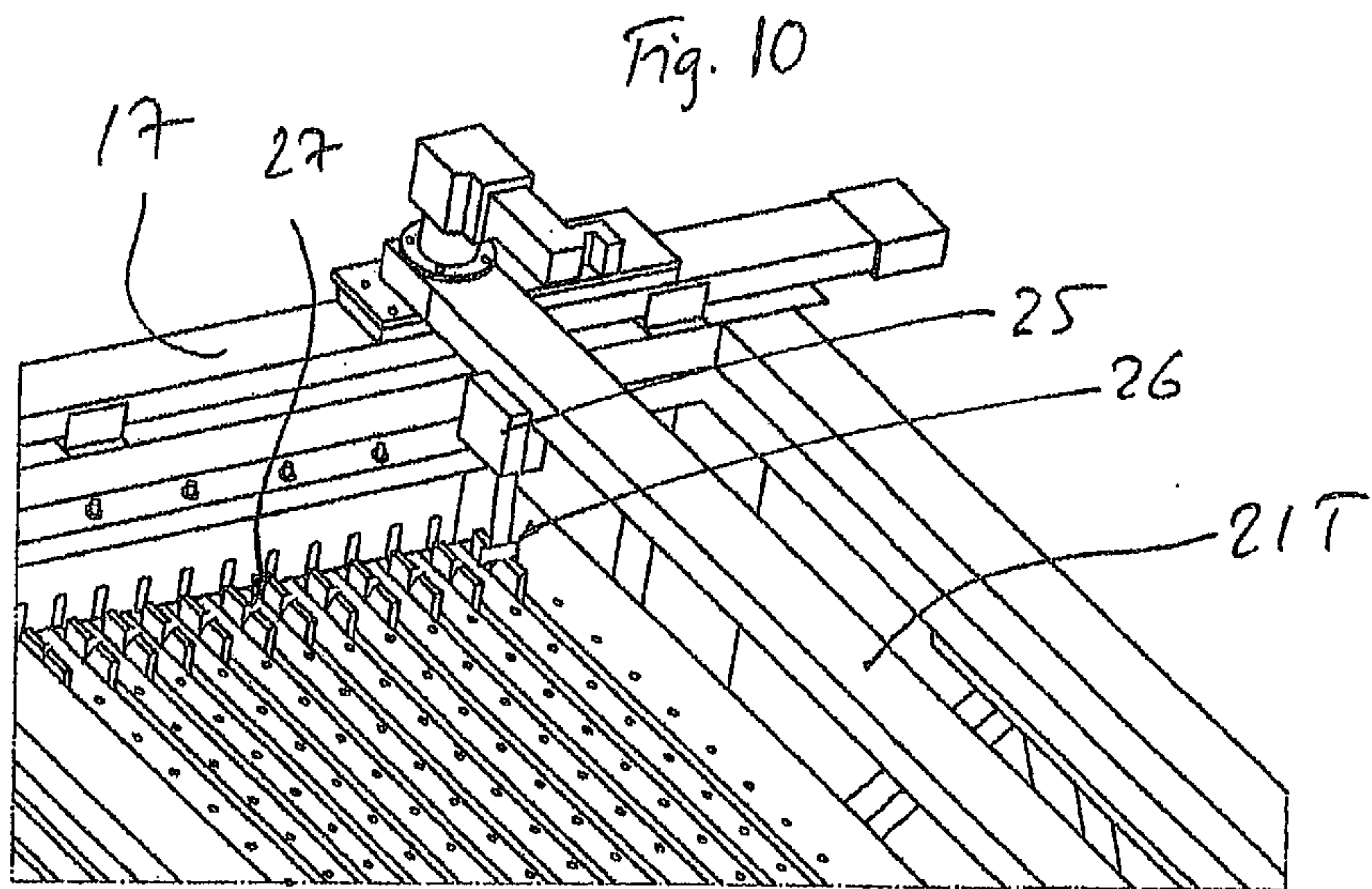

Fig. 11

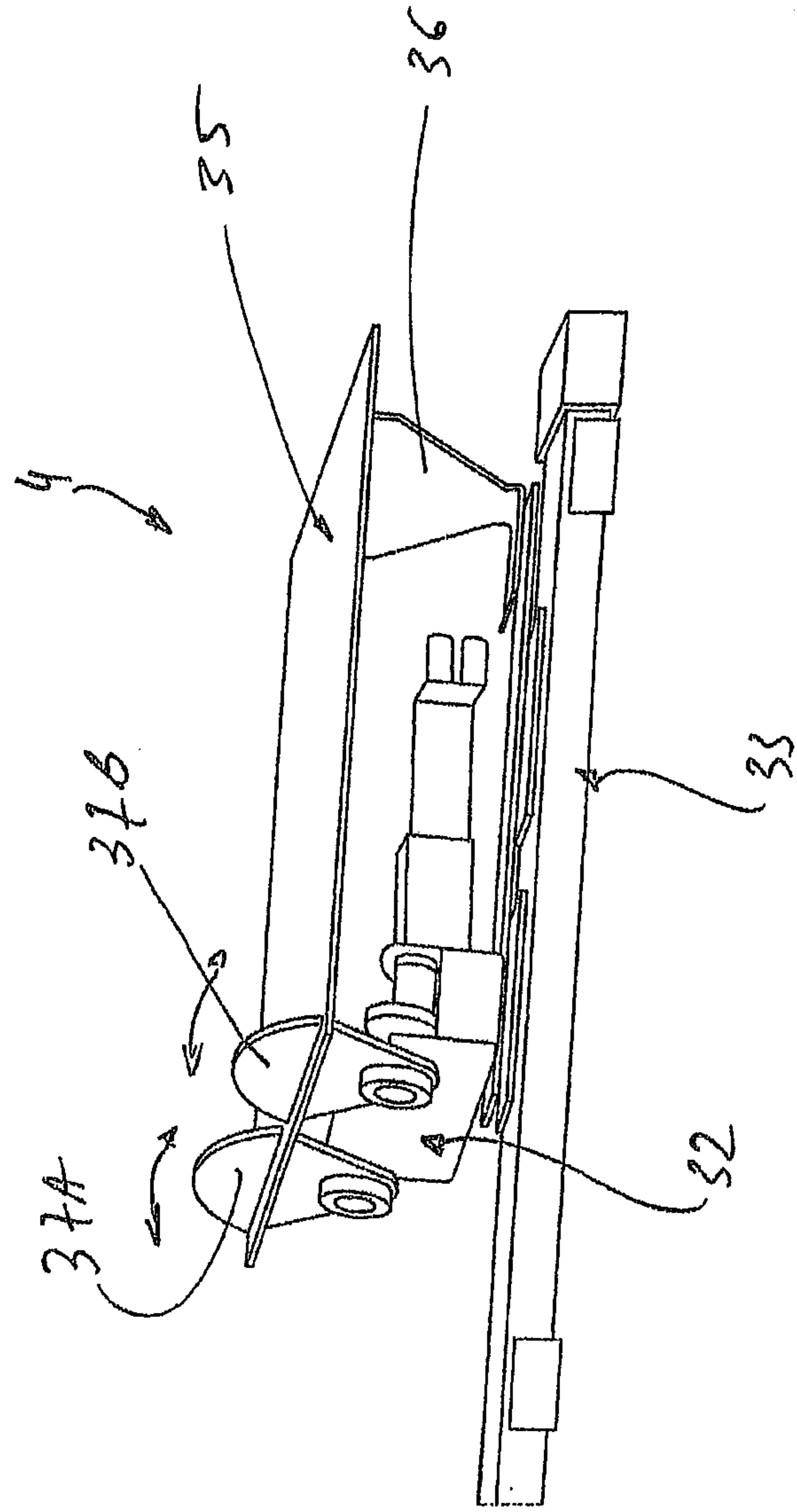
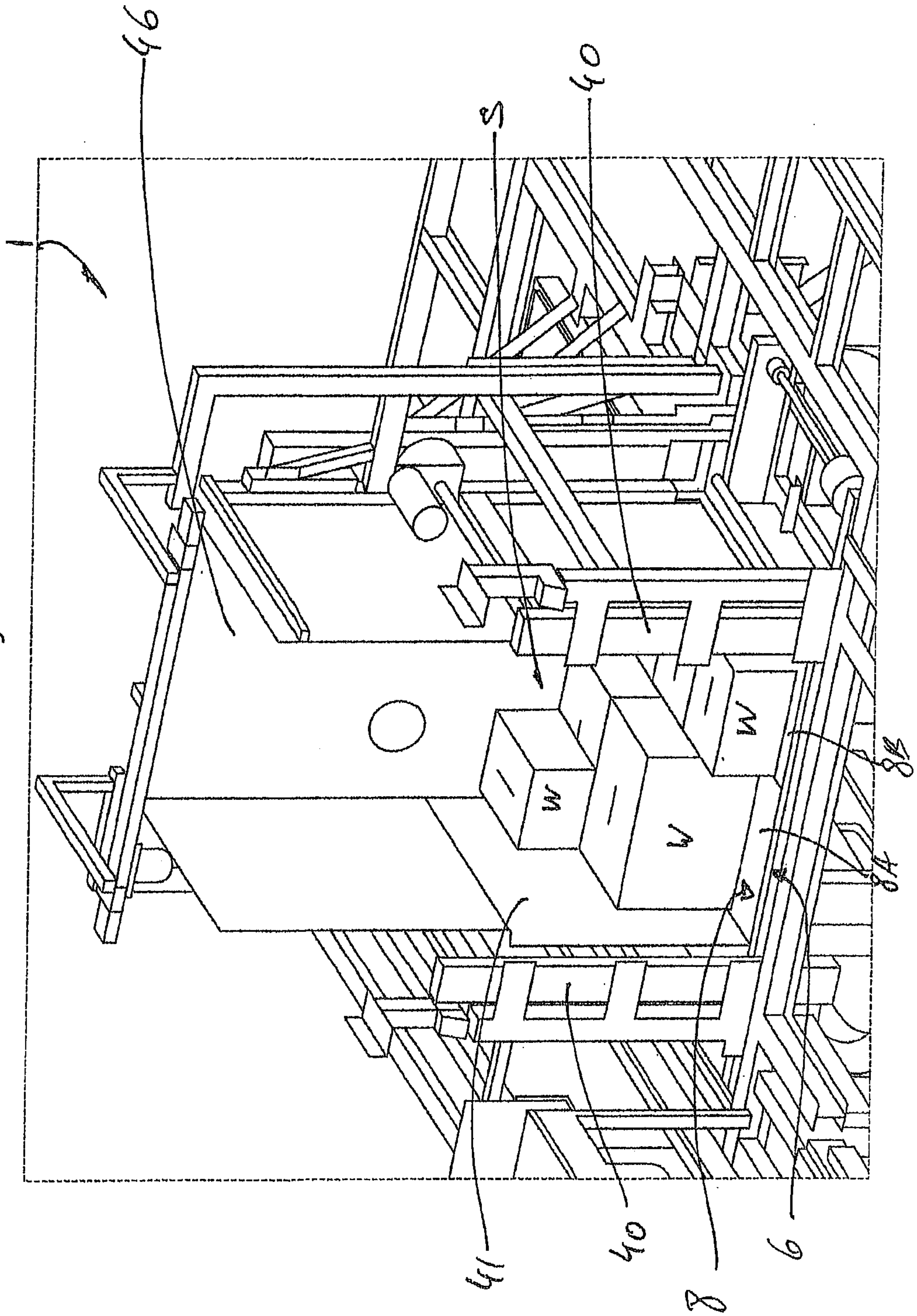

Fig. 12





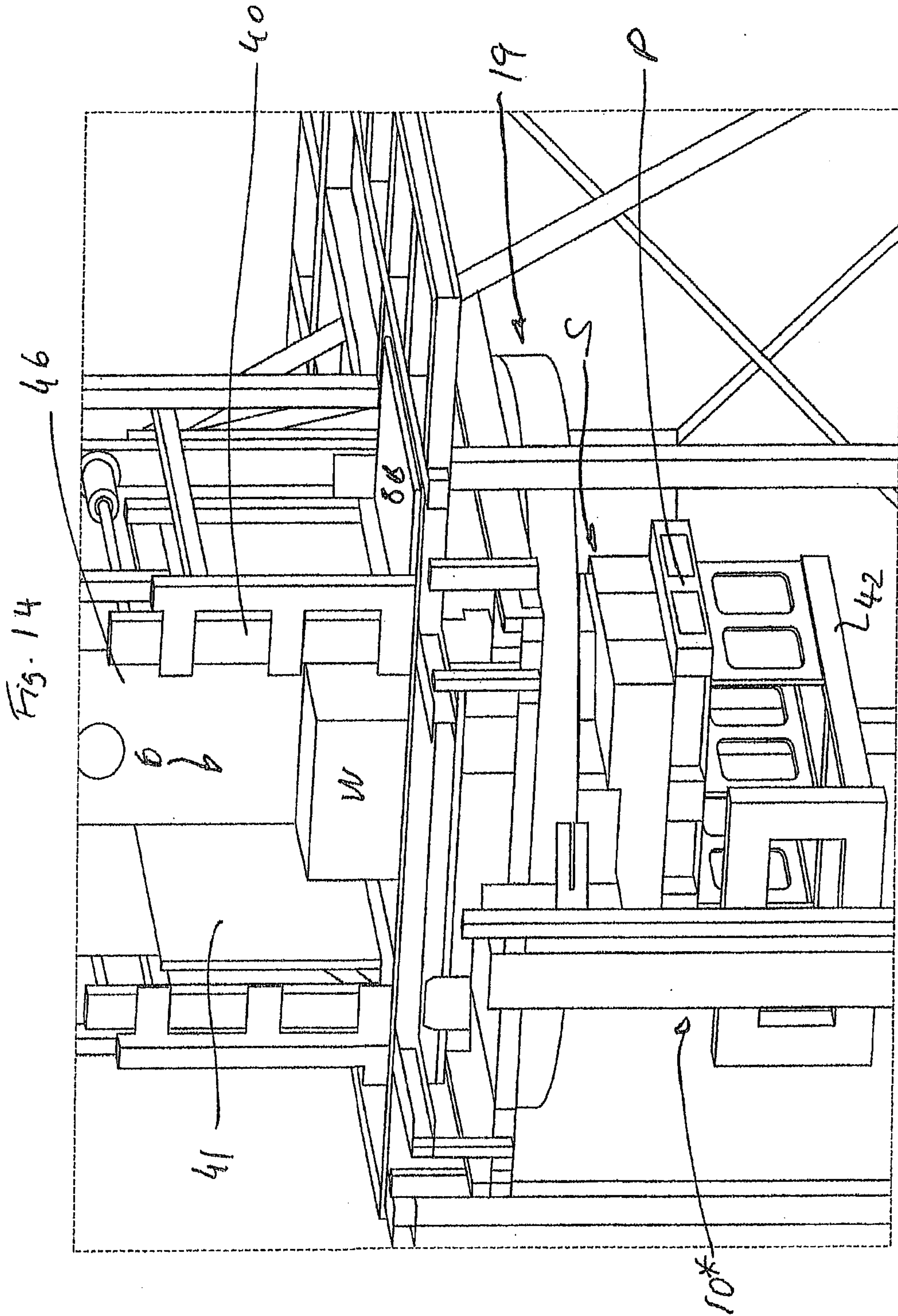
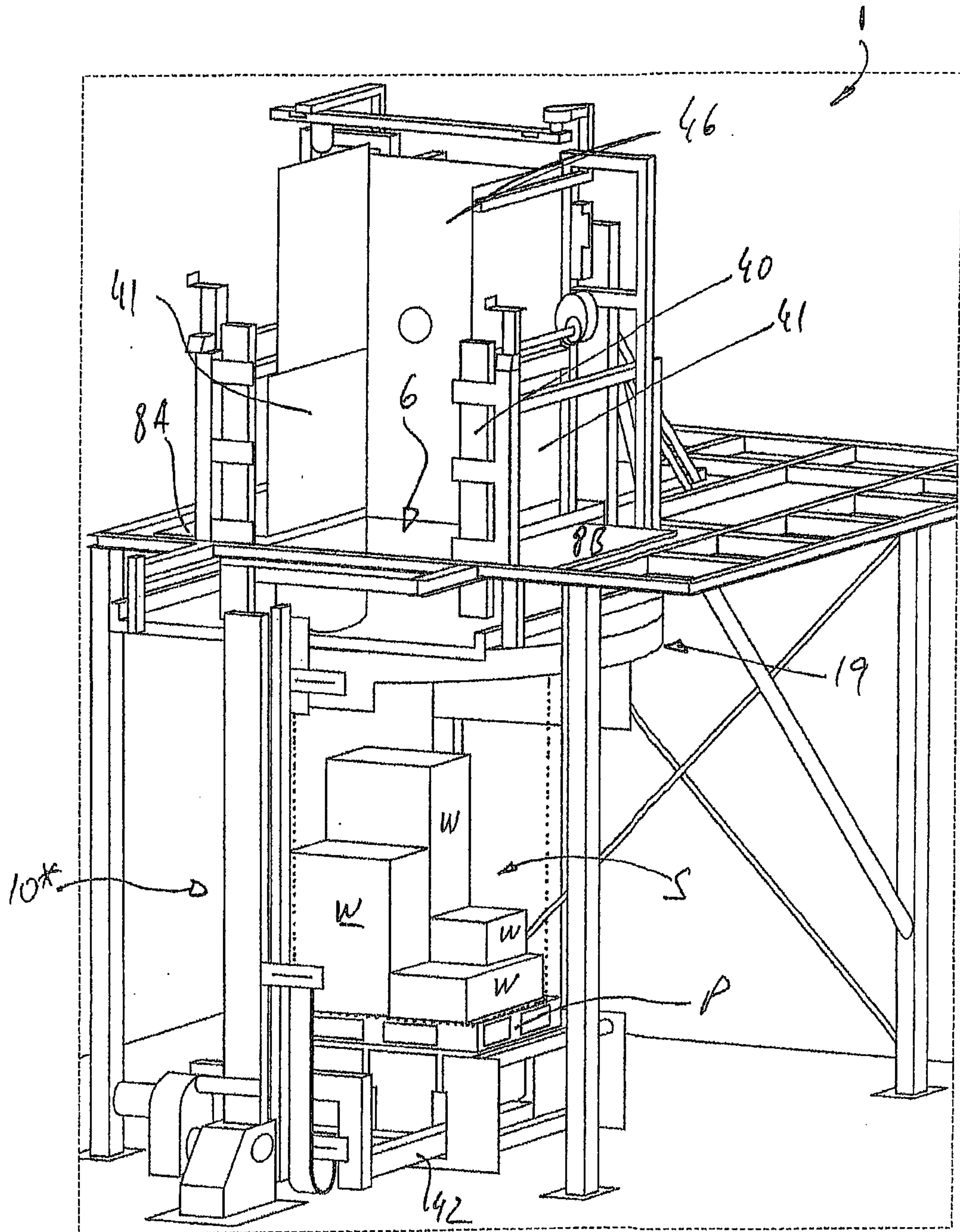

Fig. 15





16/19

Fig. 16

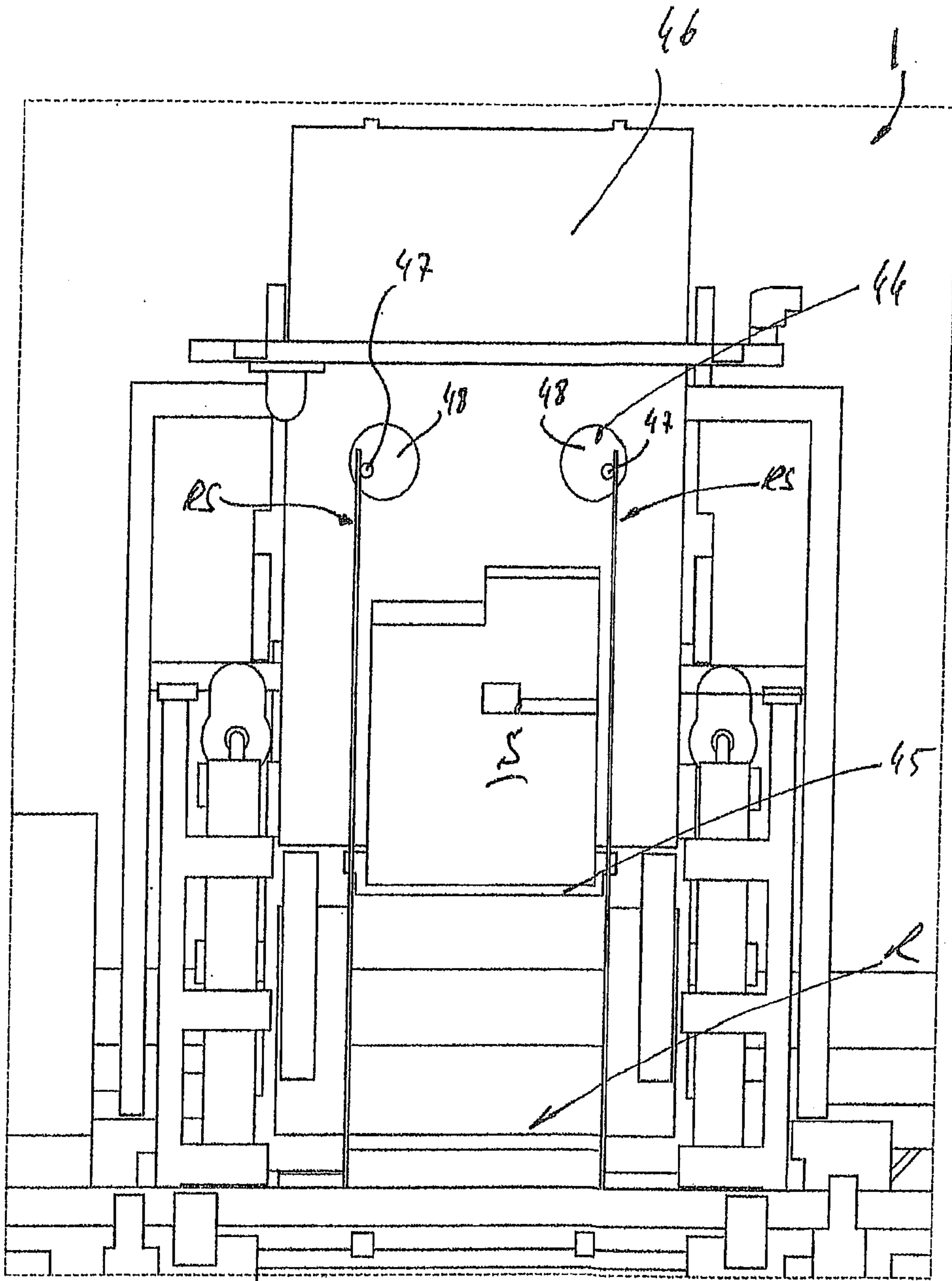

Fig. 17

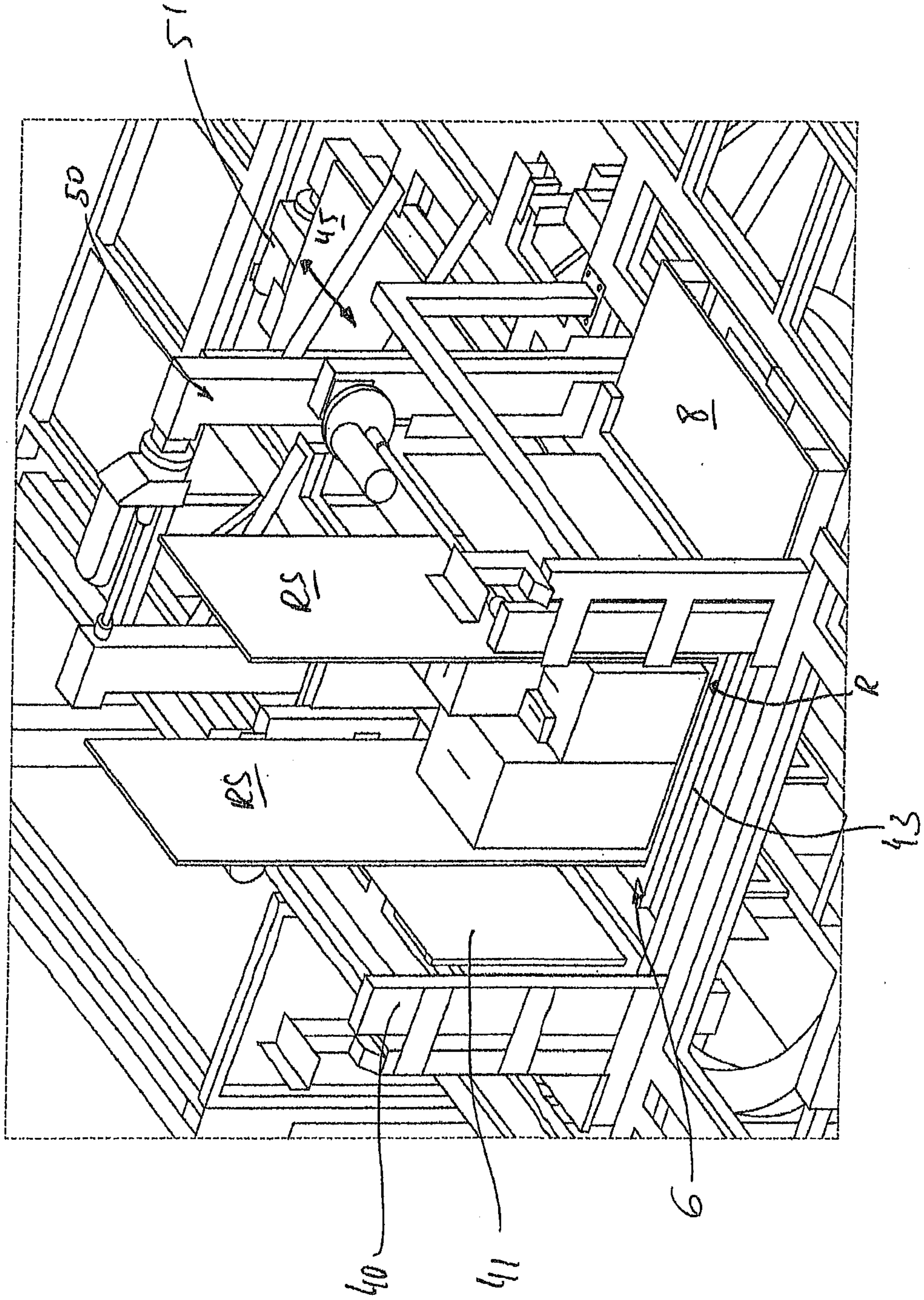

Fig. 18

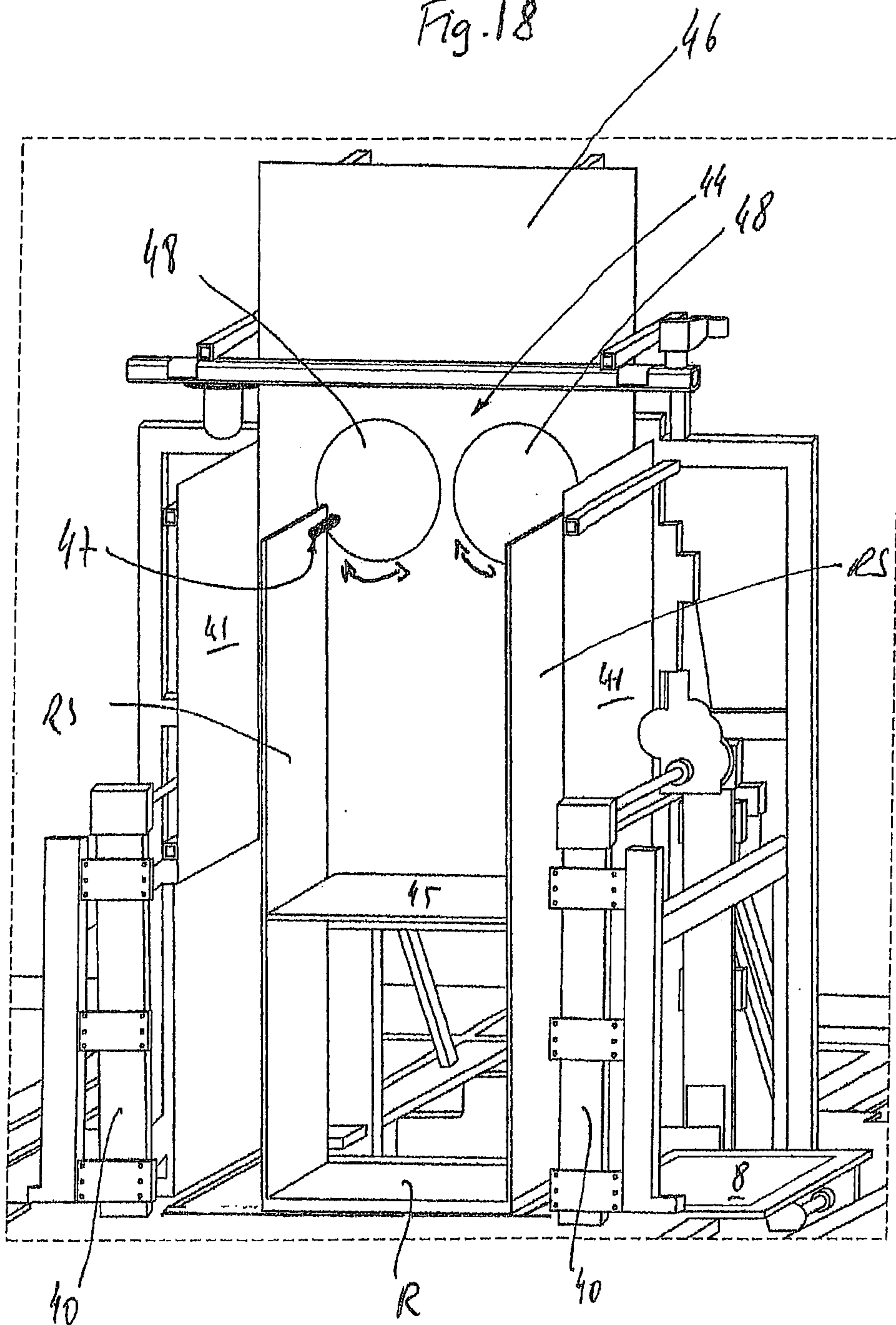

Fig. 19

