

W. D. FORSYTH.  
RAIL JOINT.  
APPLICATION FILED NOV. 7, 1910.

996,633.

Patented July 4, 1911.

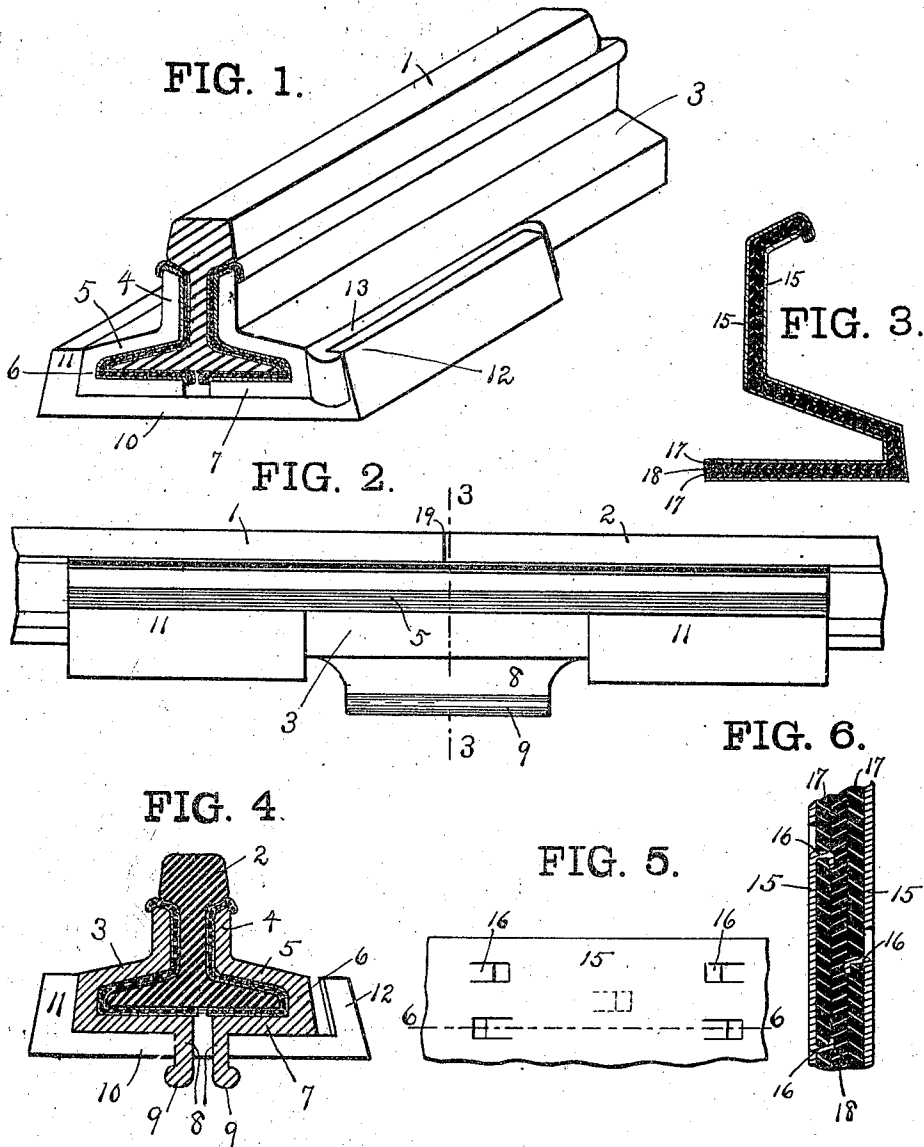

Witnesses.

Elizabeth M. Brown.

Mary A. Hawthorne.

Inventor.

William D. Forsyth

By Edward N. Pagelsen  
Attorney.

# UNITED STATES PATENT OFFICE.

WILLIAM D. FORSYTH, OF YOUNGSTOWN, OHIO.

## RAIL-JOINT.

996,633.

Specification of Letters Patent.

Patented July 4, 1911.

Application filed November 7, 1910. Serial No. 590,974.

To all whom it may concern:

Be it known that I, WILLIAM D. FORSYTH, a citizen of the United States, and a resident of Youngstown, in the county of Mahoning and State of Ohio, have invented a new and useful Rail-Joint, of which the following is a specification.

This invention relates to fish-plates, to the means for securing the fish-plates and rail ends together, and to the means which may be employed for insulating the rails from the fish-plates, and its object is to provide a cheap, effective, insulating rail-joint having great strength.

In the accompanying drawing, Figure 1 is a perspective of a section of this rail-joint. Fig. 2 is a side elevation of the same. Fig. 3 is a cross-section of the insulator on the line 3—3 of Fig. 2. Fig. 4 is a cross-section of the rail-joint on this line the key being omitted. Figs. 5 and 6 are details of the construction of the insulation, Fig. 6 being a section on the line 6—6 of Fig. 5.

Similar reference characters refer to like parts throughout the several views.

The rail-ends 1 and 2 are of any desired design and size, and on each side of these rail-ends are the fish-plates 3 which extend around the rails, the upper edges of the fish-plates engaging the rail-head, the upright parts 4 extending along the vertical web of the rails, and the parts 5, 6 and 7 extending over, along the edge, and below the flanges of the rails.

Projecting downward from the inner edges of the parts 7, are the stiffening ribs 8 having enlargements 9 at their lower edges. These ribs extend along the middle of the fish-plates only as that is the region of the greatest stress.

Extending across below both ends of the fish-plates are the bearing-plates 10 having upwardly extending jaws 11 and 12. It will be noticed that the sides 6 of the fish-plates are at an acute angle to the bottoms 7, and that the sides 11 of the bearing-plates are at the same angle. The sides 12 are preferably at a more acute angle, and between these sides and the adjacent parts 6 of the fish-plates, the keys 13 may be driven to lock the parts together. These keys are slightly tapering and are wider at their lower edges. After being driven in, their small ends may be turned over as shown in Fig. 1. By thus varying the inclination of the parts 6 of the fish-plates and the jaws 12, the keys are pre-

vented from working out and the parts will remain firmly locked together.

When it is desired to insulate the rails from the fish-plates a sheet of insulating material may be laid between the rails and each of the fish-plates. A preferred form of material is produced by forming two thin sheets of metal 15 with tongues 16, which metal sheets are secured to sheets 17 of proper insulating material, such as rubber or indurated fiber, by these tongues as shown in Fig. 6. The third sheet 18 of insulating material is then placed between the other two, and, if desired, the sheets may be cemented together, although this is not absolutely necessary. The sheets of metal protect the softer insulating material but may be omitted if desired. This rail-joint requires no bolts, it permits the usual expansion and contraction of the rails, and their ends may be insulated from each other by a thin sheet 19 of proper material. The ribs 8 prevent the fish-plates from bending under heavy loads and thus keep the rail-ends level. As the fish-plates and the rails are rigidly locked together by the keys 13, movement between the parts is prevented.

The top edge of the insulation may be turned down as shown in Fig. 3 so that the inner sheet 15 will prevent water from lodging directly on the insulating material. For the sake of clearness the insulation is shown much thicker in proportion in the drawing than it is in practice. The tongues 16 may be omitted if desired, as the curvature of the insulation will usually insure its retention. The material composing it will vary according to the location of the track and the voltage of the current in the rails. The details and proportions of the other parts of the rail joint may be changed where necessary without departing from the spirit of my invention.

Having now explained my construction, what I claim as my invention and desire to secure by Letters Patent is:

1. In a rail joint, the combination of fish-plates extending along the web and around the flanges of the rails and provided intermediate their ends with downwardly extending ribs, bearing-plates extending below and along the sides of the ends of the fish-plates, and keys to hold the bearing plates in position.

2. In a rail joint, the combination of fish-plates extending along the web and around

the flanges of the rails and provided with downwardly extending ribs intermediate their ends, bearing plates beneath the ends of the fish-plates provided with upwardly extending jaws, and a key between one of said jaws of each bearing-plate and the adjacent fish-plate.

3. In a rail-joint, the combination of fish-plates extending along the web and around the flanges of the rails, sheets of insulating material between the rails and fish-plates, bearing-plates extending across beneath the ends of the fish-plates and having jaws extending upward along the sides of the same, and a key driven in between a jaw on each bearing-plate and the adjacent fish-plate.

4. In a rail-joint, the combination of fish-plates extending along the web and around the flanges of the rails, sheets of insulation between the rails and fish-plates comprising thin sheets of metal with insulating material secured between the same, the upper edges of the insulation being turned down to bring the inner sheet of metal uppermost where the insulation is exposed to the weather and bearing-plates secured to the ends of the fish-plates to hold the parts in position.

5. In a rail-joint, the combination of imperforate fish-plates fitting against and forming bearings for the rail-ends, the lower edges of the fish-plates forming acute angles with the portions beneath the rails, bearing-plates extending below the ends of the fish-plates and having upwardly extending jaws,

one of said jaws being at the same angle as the edge of the fish-plates, and a key adapted to be driven between the other jaw and the adjacent fish-plate.

6. In a rail-joint, the combination of imperforate fish-plates fitting against and forming bearings for the rail-ends, the lower edges of the fish-plates forming acute angles with the portions beneath the rails, bearing-plates extending below the ends of the fish-plates and having upwardly extending jaws, one of said jaws being at the same angle as the edge of the fish-plates, the other jaw forming a more acute angle with the bearing-plate, and a tapering key adapted to be driven between the last named jaw and the adjacent fish-plate.

7. In a rail-joint, the combination of fish-plates extending along the web and around the flanges of the rails, sheets of insulation between the rails and the fish-plates comprising exterior sheets of metal and interior sheets of insulating material secured together by means of tongues formed on the metal sheets, and a third sheet of insulating material between the other two, and bearing-plates secured to the ends of the fish-plates to hold the parts in position.

In testimony whereof I have signed this specification in the presence of two subscribing witnesses.

WILLIAM D. FORSYTH.

Witnesses:

EDWARD N. PAGELSEN,  
ELIZABETH M. BROWN.