



US 20040084392A1

(19) **United States**

(12) **Patent Application Publication**
Richter et al.

(10) **Pub. No.: US 2004/0084392 A1**

(43) **Pub. Date: May 6, 2004**

(54) **MERCHANDISING SYSTEM**

Related U.S. Application Data

(75) Inventors: **Gary M. Richter**, Waukesha, WI (US);
M. Scott Bryson, Brookfield, WI (US);
Terrence G. Berglund, Hales Corners,
WI (US)

(60) Provisional application No. 60/409,612, filed on Sep. 10, 2002.

Publication Classification

Correspondence Address:

Scott M. Day
Foley & Lardner
Suite 3800
777 East Wisconsin Avenue
Milwaukee, WI 53202-5306 (US)

(51) **Int. Cl.⁷ A47F 1/04**

(52) **U.S. Cl. 211/59.3; 211/103; 211/106**

(57) **ABSTRACT**

A merchandising system is disclosed. The merchandising system provides for the presentation and storage of articles comprising a frame comprising a plurality of generally horizontal members configured for attachment of a holder and at least one frame member provided to rigidify the plurality of horizontal members so that the frame is resistant to deformation when the holder is attached to one or more of the plurality of horizontal members.

(73) Assignee: **DCI Marketing, Inc.**

(21) Appl. No.: **10/659,736**

(22) Filed: **Sep. 10, 2003**

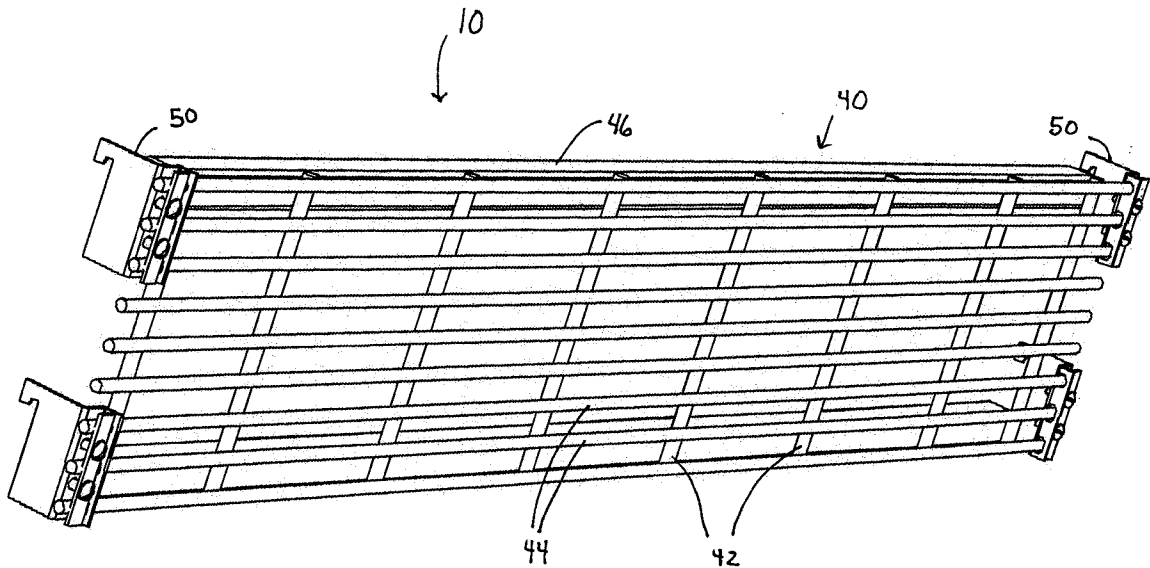

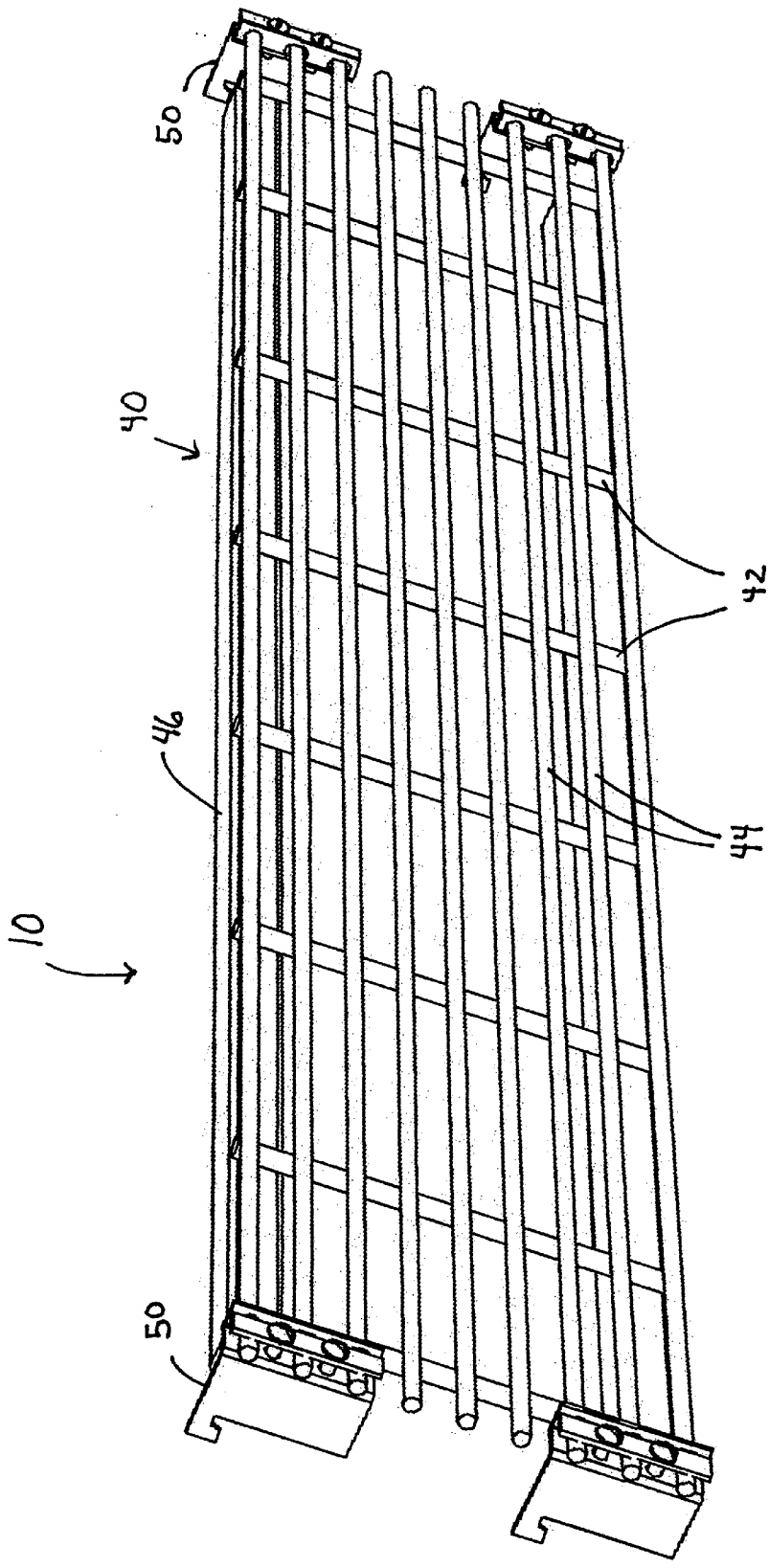

FIGURE 1

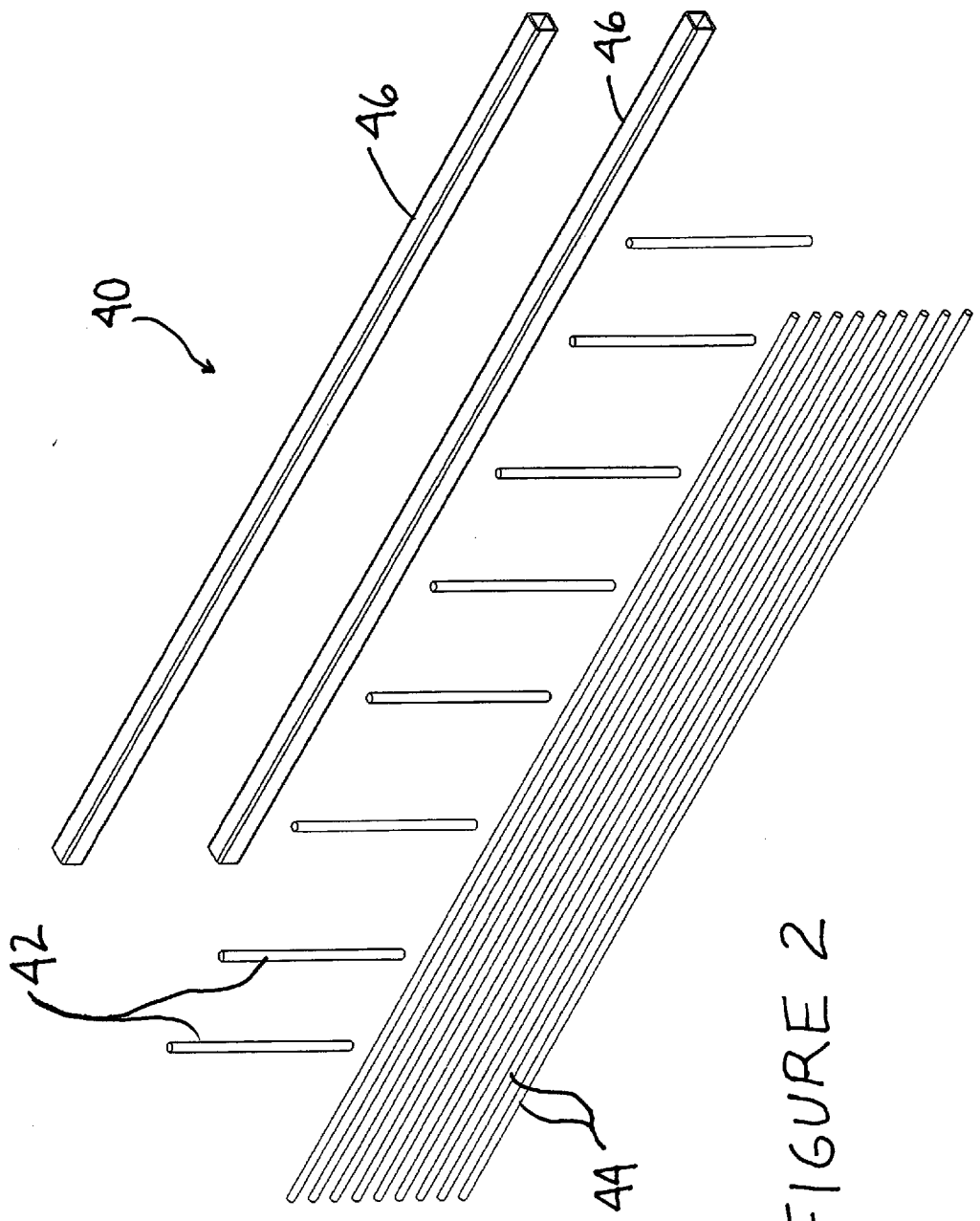

FIGURE 2

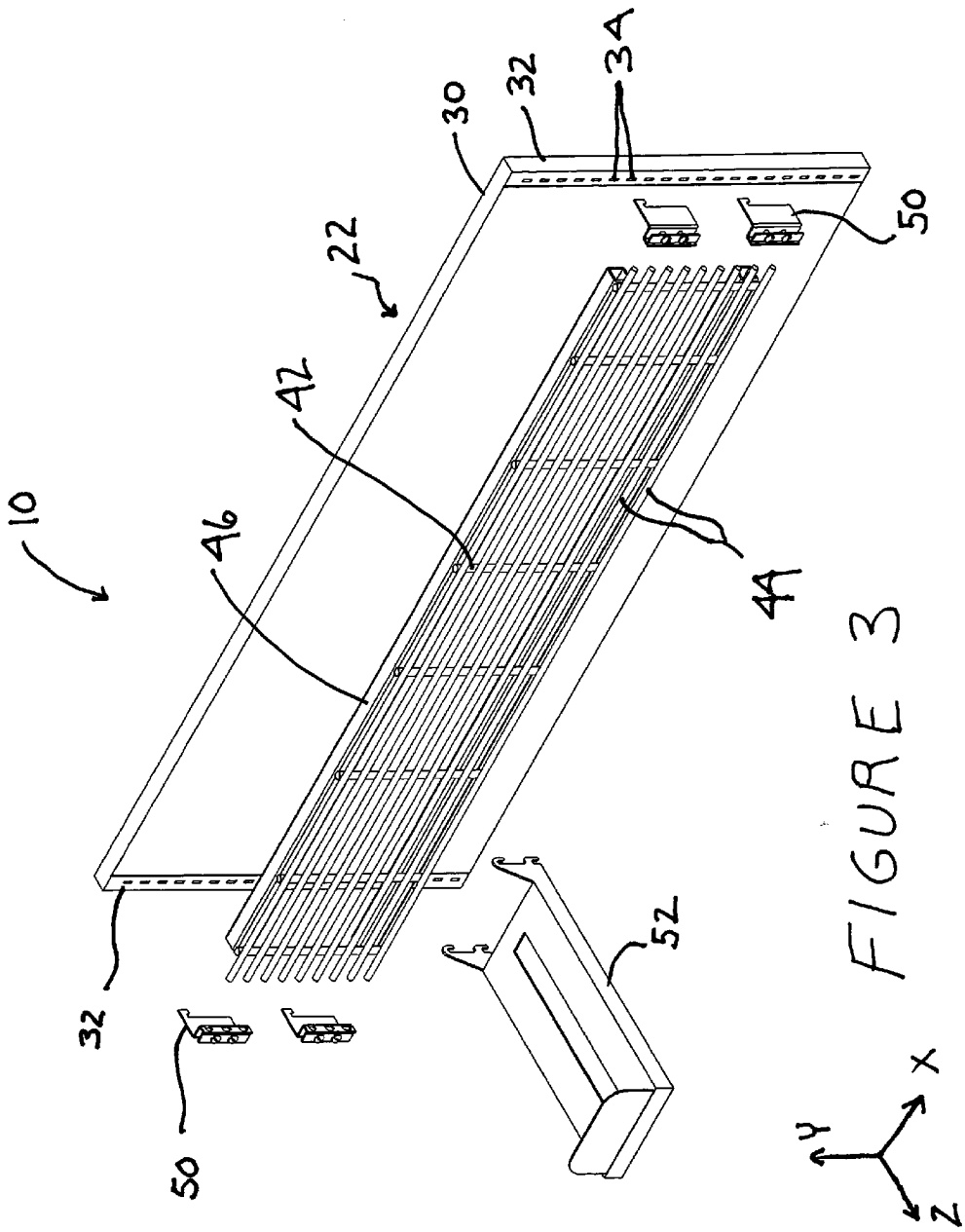

FIGURE 3

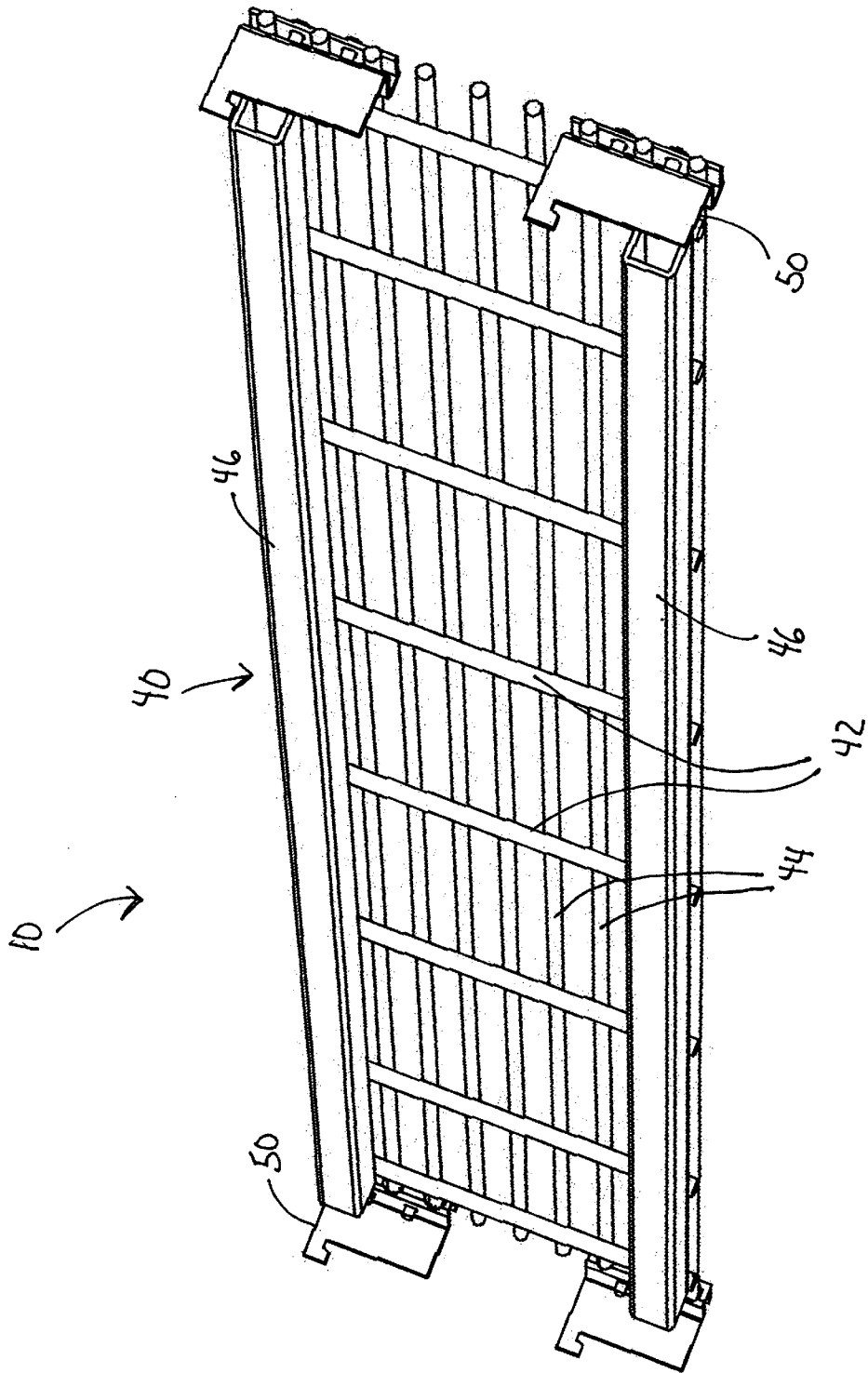

FIGURE 4

FIGURE 6

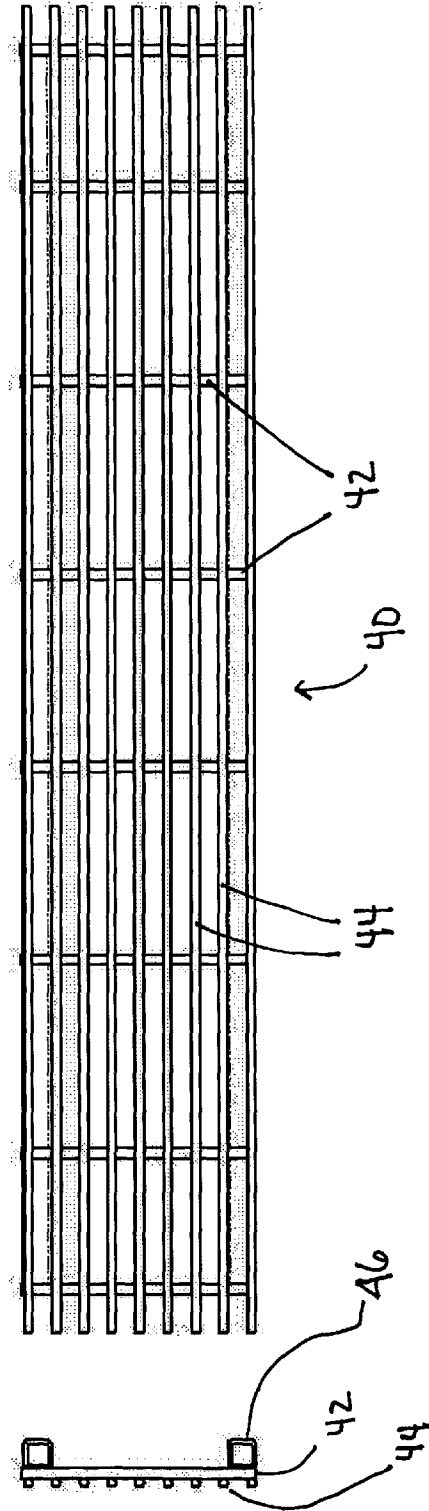

FIGURE 5

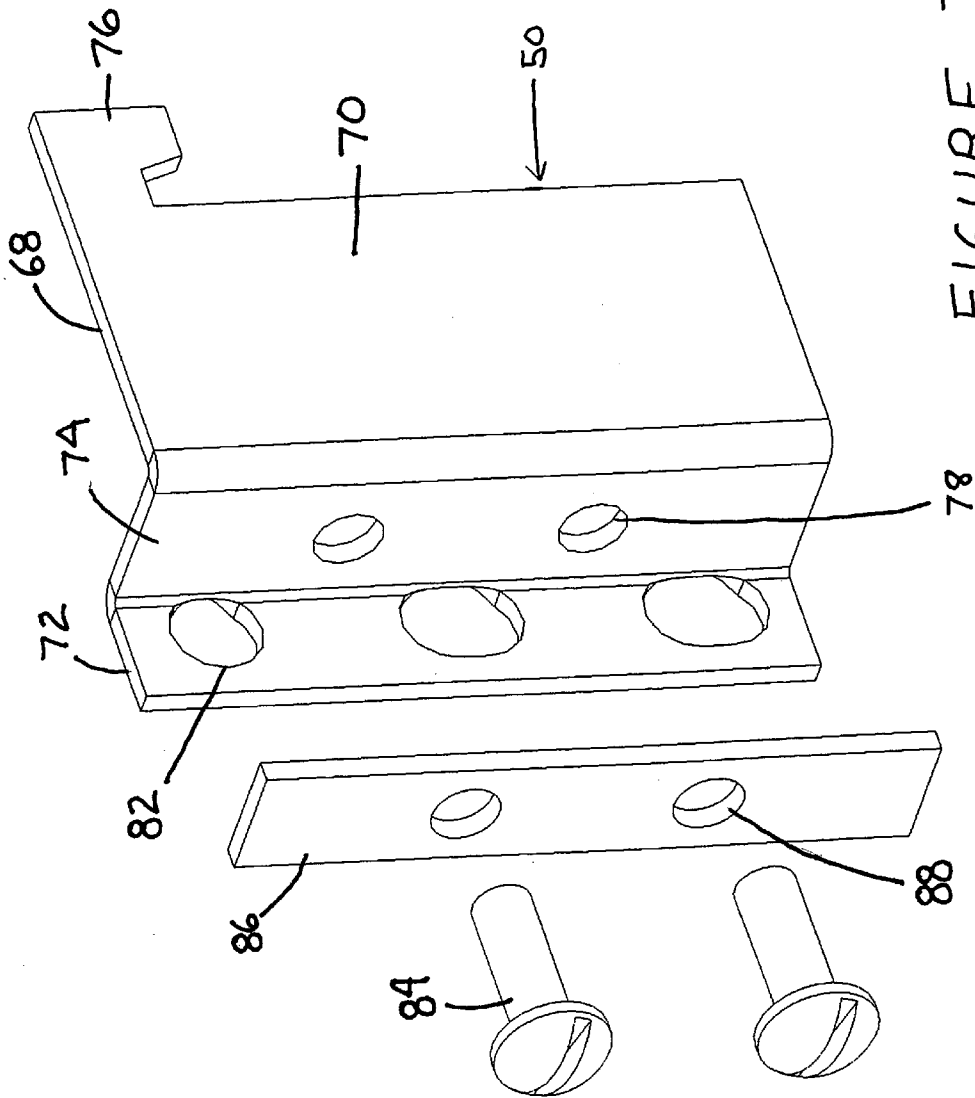
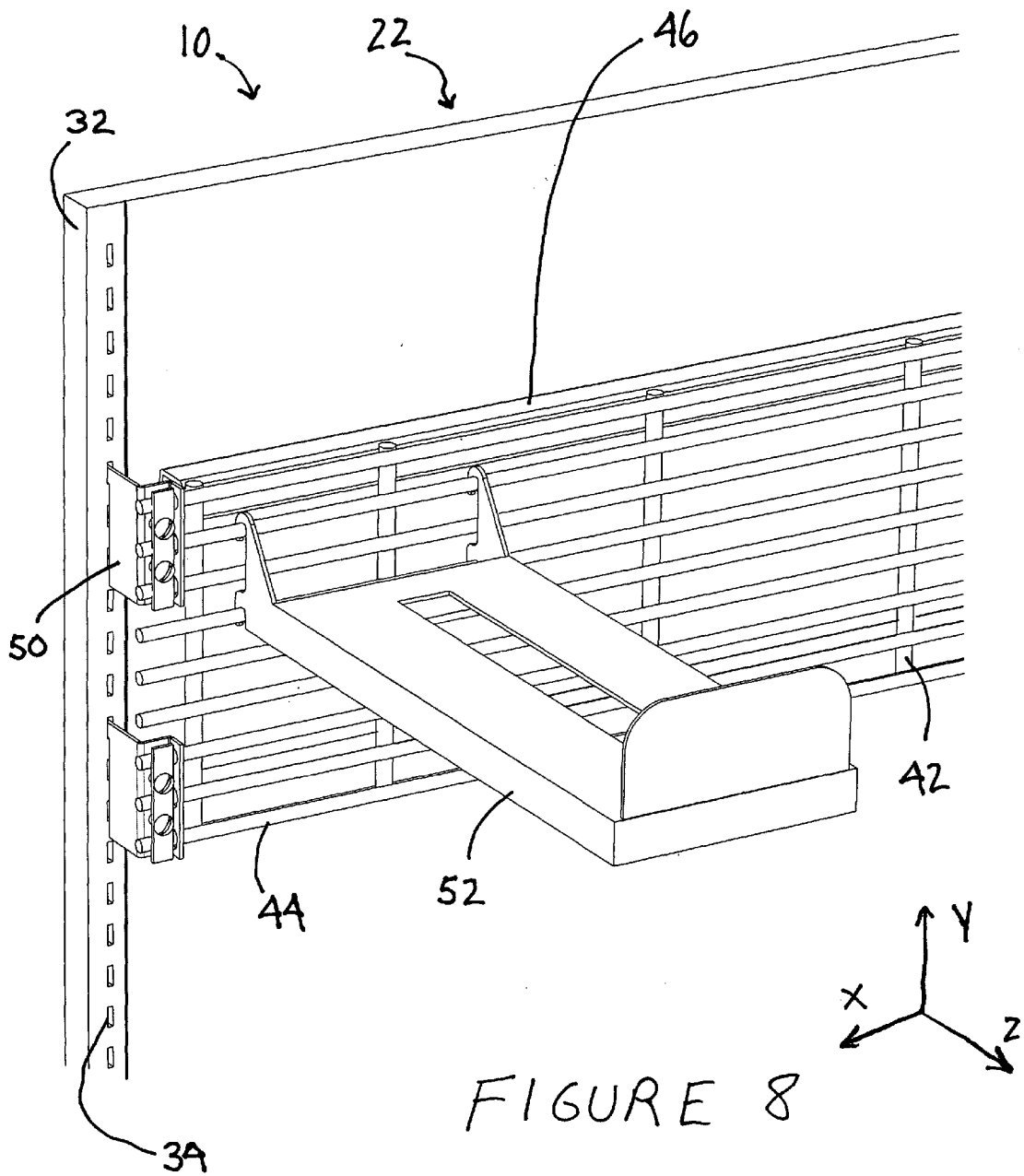

FIGURE 7



MERCHANDISING SYSTEM

CROSS-REFERENCE TO RELATED PATENT APPLICATIONS

[0001] The present application claims the benefit of priority as may be available under 35 U.S.C. §§ 119-121 from the following application: U.S. Patent Application No. 60/409,612 ("MERCHANDISING SYSTEM") filed Sep. 10, 2002 (incorporated herein by reference).

BACKGROUND

[0002] The present invention relates generally to the field of merchandising systems. In particular, the present invention relates to merchandising systems providing for support of articles and/or one or more tray systems.

[0003] It is known to provide for a merchandising system that may be used for displaying articles in consumer settings such as grocery stores, retail outlets, shops, etc. Such known merchandising systems may be used to present, display and store articles in fixed or limited spaces such as on shelves, in display cases, cabinets, etc.

[0004] It is beneficial when merchandising articles to allow potential customers to view or handle them in a convenient and comfortable manner. It is also beneficial to be able to provide for relatively neat and orderly presentation of articles. However, within fixed or limited spaces, known merchandising systems may not be configured to allow for relatively neat and orderly presentation of articles. Such known merchandising systems do not always provide articles and/or one or more tray systems in straight, linear, and/or level arrangements. For example, some known merchandising systems do not provide strong and/or rigid support for articles and/or one or more tray systems. This supportive configuration can be an important feature for customers and store personnel because it enables articles to be merchandised with less sagging, deformation, and/or movement of the merchandising system.

[0005] Accordingly, it would be advantageous to provide a merchandising system that may provide for relatively neat and orderly presentation of articles. It would also be advantageous to provide a merchandising system that may provide a strong and/or rigid support for article and/or one or more tray systems. It would also be advantageous to provide a merchandising system that may provide articles and/or one or more tray systems in straight, linear, or level arrangements. It would also be advantageous to provide a merchandising system that may be configured to resist sagging, deformation, bowing, and/or movement due to article weight. It would also be advantageous to provide a merchandising system that may provide a rigid support for article having relatively high weight and/or density.

[0006] It would be advantageous to provide a merchandising system or the like of a type disclosed in the present application that provides any one or more of these or other advantageous features.

SUMMARY

[0007] The present invention relates to a merchandising system for presenting and storing products. The merchandising system comprises a grid comprising a plurality of vertical members and a plurality of horizontal members

arranged in a generally planar configuration and oriented so that one or more tray systems may be attached to the grid at select locations. In addition, the merchandising system comprises members coupled to the grid and providing support to the grid to maintain the generally planar configuration of the grid when the one or more tray systems are attached to the grid.

[0008] The present invention also relates to a merchandising system for supporting tray systems comprising a support assembly having vertical members and horizontal members and configured so that the tray systems may be attached at select locations. In addition, the merchandising system includes at least one member fixedly attached to the support assembly and configured to resist deformation of the support assembly.

[0009] The present invention also relates to a merchandising system for storing and presenting products on a shelf or display case comprising a means for supporting a plurality of tray systems at select locations, and a means for providing strength and rigidity to the merchandising system and configured to resist deformation of the means for supporting the plurality of tray systems.

[0010] The present invention also relates to a merchandising system for supporting products comprising a plurality of vertically oriented members, a plurality of horizontally oriented members coupled to the vertically oriented members in a grid formation, and frame members coupled to the vertically oriented members such that the grid formation resists deformation.

[0011] The present invention also relates to a merchandising system for presenting and storing articles comprising a frame comprising a plurality of generally horizontal members configured for attachment of a holder, and at least one frame member provided to rigidify the plurality of horizontal members so that the frame is resistant to deformation when the holder is attached to one or more of the plurality of horizontal members.

BRIEF DESCRIPTION OF THE DRAWINGS

[0012] FIG. 1 is a front perspective view of a merchandising system according to an exemplary embodiment.

[0013] FIG. 2 is an exploded front perspective view of the merchandising system.

[0014] FIG. 3 is an exploded front perspective view of the merchandising system.

[0015] FIG. 4 is a rear perspective view of the merchandising system.

[0016] FIG. 5 is a front and side view of merchandising system according to an exemplary embodiment.

[0017] FIG. 6 is a top view of a merchandising system according to an exemplary embodiment.

[0018] FIG. 7 is a front perspective view of a fastener for use with a merchandising system according to an exemplary embodiment.

[0019] FIG. 8 is a front perspective view of a merchandising system according to an exemplary embodiment.

DETAILED DESCRIPTION OF EXEMPLARY EMBODIMENTS

[0020] Referring to FIGS. 1 through 8, various exemplary and alternative embodiments of a merchandising sys-

tem intended for displaying articles such as products, containers, items, units, etc. in consumer settings such as grocery stores, retail outlets, shops, etc. are shown. According to a preferred embodiment, the merchandising system is intended to dispense, store, merchandise, display, etc. articles to provide for the space-efficient presentation of groups of articles within a given or fixed display area, and/or to allow for convenient and orderly presentation, dispensing, and storage of articles (such as products or product containers) having any of a wide variety of sizes, shapes, and profiles (e.g., rectangular, non-rectangular, etc.).

[0021] FIGS. 1 through 8 show a merchandising system 10 according to an exemplary embodiment. System 10 includes a base 22 (e.g., grid, support, frame, framework, backing, etc.) having a frame 30 and a grid 40. The grid 40 includes vertical members 42, horizontal members 44, and frame members 46.

[0022] According to various exemplary embodiments, one or more tray system 52 (e.g., tray, holder, carrier, container, shelf, platform, etc.) may be provided. The tray system may be provided on an existing merchandising system such as a shelf, grid system, display case, etc. The tray system may be configured to hold, display, retain, store, or otherwise receive articles such as product (e.g., goods, displayed objects, etc.). The tray system may provide for the space division and orderly and convenient presentation of such articles.

[0023] As shown in FIGS. 3 and 8, base 22 comprises a frame 30 (e.g., vertical component/element, frame, stand, member, etc.) and grid 40 (e.g., grid module, wire module, wire frame, support, support element, etc.). Base 22 may be configured to connect or couple adjacent systems into a larger overall merchandising system. According to a preferred embodiment, the base has a “modular” construction and facilitates use with other bases, shelves, or a variety of other existing merchandising systems, including shelving units, support surfaces, grids, brackets, hangers, etc.

[0024] According to an exemplary embodiment, the frame 30 may comprise one or more members 32 (e.g., vertical component, vertical element, etc.). As shown in FIGS. 3 and 8, the frame 30 comprises two vertical members 32. A number of apertures 34 (e.g., slots, mounting points, etc.) may be provided along members 32 as shown in FIGS. 3 and 8. Apertures 34 provide a mounting area for attaching grid 40 to members 32.

[0025] Frame 30 may be attached to a wall, floor, base, support, stand, etc. to provide stability or overall support to the merchandising system. For example, the frame may be attached to a cooler in a retail or display setting. According to other exemplary embodiments, the frame may be attached to any shelving or display system. According to various alternative embodiments, the frame may be omitted and the one or more grid may be coupled directly to other support structures (e.g., screwed, bolted, etc. directly to a wall, case, frame, etc.).

[0026] According to an exemplary embodiment, one or more grid 40 (e.g., grid module, wire module, wire frame, support, support assembly, etc.) may be coupled to frame 30. According to a preferred embodiment, the grid has a “modular” construction and facilitates use with many structures, shelves, bases, etc. According to an exemplary embodiment,

brackets 50 are provided to couple the grid 40 to the frame 30. As an example, the brackets may be similar to those disclosed in U.S. Pat. No. 5,769,248, the entire disclosure of which is incorporated herein by reference.

[0027] According to an exemplary embodiment, merchandising system 10 may include right and left brackets for use on either the corresponding right or left side of the system 10. Right and left brackets may be mirror images of one another. FIG. 7 shows a right bracket 50 according to an exemplary embodiment. Bracket 50 includes a generally z-shaped member 68 having a first leg 70, a second leg 72, and a center portion 74. The first leg 70 is generally rectangular and includes a hook portion 76 extending outwardly from the first leg 70 in a direction away from the second leg 72 and away from the center portion 74. The hook portion 76 is configured to engage with the apertures 34 of the members 32. The center portion 74 is generally rectangular and is at about a 90 degree angle with respect to the first leg 70. The center portion 74 has apertures 78 with diameters of about $\frac{1}{8}$ to $\frac{1}{2}$ inches, preferably about $\frac{1}{4}$ inches. The second leg 72 is also generally rectangular and oriented at about a 90 degree angle with respect to the center portion 74 extending outwardly from the center portion 74 in a generally parallel orientation to the first leg 70. The second leg 72 has three holes 82 spaced so as to correspond to the spacing of horizontal members 44 of the grid 40. The bracket 50 is preferably integrally formed as one piece and is made from steel.

[0028] According to an exemplary embodiment, a pair of screws 84 and plate 86 may be used to secure grid 40 to brackets 70. Plate 86 is generally rectangular and has apertures 88 configured to hold screws 84. Plate 86 is preferably made from steel.

[0029] To secure grid 40 to members 32, bracket 50 is assembled by threading each screw 84 through an aperture 88 in plate 86 then through center portion 74 through an aperture 78 such that plate 86 is between the head of screw 84 and center portion 74. The horizontal members 44 are inserted in holes 82 in the second leg 72. The horizontal members 44 should be positioned between the plate 86 and the center portion 74. Screws 84 may be tightened such that the plate 86, screws 84 and bracket 50 cooperate to secure the horizontal members 44 in place. This procedure may be repeated on the left side. The grid 40 with brackets 50 attached can then be secured to the members 32 (or other support assembly) by placing the hook portions 76 of brackets 50 in a respective aperture 34 in members 32.

[0030] Grid 40 may comprise one or more vertical members 42, one or more horizontal members 44, and one or more frame members 46. As shown in FIGS. 1 through 6, and 8, one or more vertical member 42 (e.g., wire, rod, tube, extended member, etc.) may be provided for the grid 40. The vertical members 42 add strength and/or rigidity to the grid 40. According to a particularly preferred embodiment, eight vertical members 42 are provided. According to other alternative embodiments, any number of vertical wires may be provided for the grid. The vertical members 42 prevent the horizontal members 44 from bending, deforming, “drooping”, or otherwise being moved from position.

[0031] The vertical members 42 are spaced apart from each other along a width of the grid 40. According to an exemplary embodiment, the vertical members 42 are spaced

apart about 2.5 inches to 8.5 inches, preferably about 4.875 inches to 6.925 inches. According to an exemplary embodiment, the diameter of the vertical members **42** is about 0.1 to 0.5 inches, preferably about 0.375 inches. According to other alternative embodiments, the vertical members may be placed and/or arranged along some or all of the width of the grid according to any suitable configuration.

[0032] According to an exemplary embodiment, one or more horizontal members **44** (e.g., wire, rod, tube, extended member, etc.) may be provided with the grid **40**. The horizontal members **44** may be configured to work with one or more tray systems and provide flexibility in the positioning and placement of the various trays. According to an exemplary embodiment, eighteen horizontal members **44** are provided, each spaced approximately one inch apart. According to another embodiment shown in **FIGS. 1 through 6**, and **8**, nine horizontal members **44** are provided. According to other alternative embodiments, any number of members may be provided along the grid. The horizontal members may be spaced apart from each other along any portion or the entire width of the grid. According to an exemplary embodiment, the diameter of the horizontal member may be about 0.1 to about 0.5 inches, preferably about 0.306 to 0.312 inches.

[0033] According to an exemplary embodiment, one or more frame members **46** (e.g., member, tube, L-channel, C-channel, U-channel, square tube backer, reinforcement, etc.) may be provided with the grid **40**. According to a preferred embodiment shown in **FIGS. 1 through 5**, and **8**, the grid **40** may have two frame members **46** (shown as square tubes) provided on the back side of the grid **40**. According to alternative embodiments, the frame members **46** may have a variety of shapes, including L-channels, C-channels, U-channels, round shapes, etc. According to an exemplary embodiment, the frame member may be a square tube made from about 9 to 13 gauge steel having sides measuring about 0.5 to 2.0 inches in length. According to a preferred embodiment, the frame member is about a one inch square tube made from about 11 gauge steel.

[0034] As shown in **FIGS. 1, 3 through 6**, and **8**, the frame member **46** may be coupled, fastened or attached to the vertical members **42**. According to a preferred embodiment, the frame member **46** is welded to the vertical members **42**. According to alternative embodiments, any fastening method or technique may be used, including adhesives, mechanical fasteners, etc.

[0035] As shown in **FIGS. 1 through 6**, and **8**, the frame member **46** may extend along the length of the grid **40**. According to a preferred embodiment, a frame member **46** may be provided along the upper and lower portions of the grid **40**. According to alternative embodiments, one or more frame members may be provided on the grid in any variety of locations, including the center, upper and/or lower portion of the grid. According to other embodiments, the frame member may extend in any direction on the grid (e.g., up, down, diagonal, etc.) and may extend across only a portion of the grid (e.g., across half of the grid). According to other embodiments, the frame member may comprise separate parts or elements connected to each other or may be formed integrally as one part.

[0036] According to an exemplary embodiment, one or more tray system (e.g., tray, storage, holder, container,

divider system, etc.) may be provided in the merchandising system. One or more tray systems may be provided in the merchandising system to display and/or store articles. According to one exemplary embodiment, the tray system may be of a type disclosed in U.S. Pat. No. 5,769,248. According to various alternative embodiments, any number of suitable trays, dividers, storage bins, holders, etc. may be provided in the merchandising system.

[0037] According to various exemplary embodiments, the assemblies and components of the merchandising system may be constructed from a variety of suitable materials, including metals, alloys, composites, etc. According to an exemplary embodiment, the horizontal members of the grid are assembled and constructed from steel wire having a diameter of about 0.25 to about 0.35 inches, preferably about 0.306 to 0.312 inches. According to an exemplary embodiment, the frame member may be a square tube made from about 9 to 13 gauge steel having sides measuring about 0.5 to 2.0 inches in length. According to a preferred embodiment, the frame member is about a one inch square tube made from about 11 gauge steel.

[0038] Conventional arrangements of merchandising systems may allow "sagging" or "drooping" of the tray systems provided on the merchandising system. For example, tray systems may be provided on a grid. The tray systems may be used to display and/or store articles. The articles may have a high weight and/or density. Conventional merchandising systems may not be fully suited to display and/or store heavy weight or high density articles. The weight of the articles may cause deformation and/or movement of the grid. For example, the grid may deform, and/or move in a number of directions, including along axis X-X shown in **FIGS. 3 and 8**, along axis Y-Y shown in **FIGS. 3 and 8**, along axis Z-Z shown in **FIGS. 3 and 8**, and twisting or torsional deformation and/or movement along other axes and directions.

[0039] The exemplary embodiments of disclosed merchandising system have increased strength and/or rigidity. The merchandising system shown in the FIGURES allows for the presentation of articles along straight and/or linear lines. For example, horizontal rows of trays may be presented to a customer in a relatively neat or orderly straight line (e.g., parallel to axis X-X in **FIG. 8**, generally planar, etc.). The grid also resists deformation or movement in a direction shown along axis Z-Z in **FIG. 8** and axis Y-Y in **FIG. 8**. The resulting displayed articles may be displayed along linear, orderly lines for viewing by a customer.

[0040] The frame members provided on the grid assist in strengthening and/or rigidifying the merchandising system to resist sagging or deformation. The vertical wires, having larger diameters, also help to resist sagging or deformation. Accordingly, the merchandising system shown in the FIGURES reduces movement and/or deformation due to the weight of articles. This results in the display, storage and/or presentation of articles in the trays being relatively more neat, orderly, linear, straight, etc.

[0041] It is important to note that the construction and arrangement of the elements of the merchandising system as shown in the preferred and other exemplary embodiments is illustrative only. Although only a few embodiments of the present inventions have been described in detail in this disclosure, those skilled in the art who review this disclosure will readily appreciate that many modifications are possible

(e.g., variations in sizes, dimensions, structures, shapes and proportions of the various elements, values of parameters, mounting arrangements, use of materials, colors, orientations, etc.) without materially departing from the novel teachings and advantages of the subject matter recited. It is important to note that any dimensions shown are dimensions of particularly preferred embodiments, and are not intended to be limited to those dimensions. Elements shown as integrally formed may be constructed of multiple parts or elements show as multiple parts may be integrally formed, the operation of the interfaces may be reversed or otherwise varied, the length or width of the structures and/or members or connector or other elements of the system may be varied, the nature or number of adjustment positions provided between the elements may be varied (e.g., by variations in the number of engagement slots or size of the engagement slots or type of engagement). It should be noted that the elements and/or assemblies of the system may be constructed from any of a wide variety of materials that provide sufficient strength or durability, in any of a wide variety of colors, textures and combinations. It should also be noted that the system may be used in association with a rotating display, or alternatively other, fixed and non-movable displays or any of a wide variety of other surfaces in any of a wide variety of other applications. Accordingly, all such modifications are intended to be included within the scope of the present inventions. The order or sequence of any process or method steps may be varied or re-sequenced according to alternative embodiments. In the claims, any means-plus-function clause is intended to cover the structures described herein as performing the recited function and not only structural equivalents but also equivalent structures. Other substitutions, modifications, changes and omissions may be made in the design, operating conditions and arrangement of the preferred and other exemplary embodiments without departing from the spirit of the present inventions.

What is claimed is:

1. A merchandising system for presenting and storing articles comprising:

a grid comprising a plurality of vertical members and a plurality of horizontal members arranged in a generally planar configuration and oriented so that one or more tray systems may be attached to the grid at select locations; and

members coupled to the grid and providing support to the grid to maintain the generally planar configuration of the grid when the one or more tray systems are attached to the grid.

2. The merchandising system of claim 1 wherein the members comprise at least one of the following structures: (a) a square tube, (b) an L-channel, (c) a C-channel, and (d) a U-channel.

3. The merchandising system of claim 2 wherein the members comprise about a one inch square tube of about 11 gauge steel.

4. The merchandising system of claim 3 wherein the members are coupled to the vertical members so that the grid resists deformation in one or more directions.

5. The merchandising system of claim 1 wherein the plurality of vertical members and the plurality of horizontal members are generally perpendicular to one another when the one or more tray systems are attached to the grids.

6. The merchandising system of claim 1 wherein the members provide support to the grid so that articles may be presented and stored along generally linear lines.

7. The merchandising system of claim 1 wherein the grid is configured to support tray systems of different sizes interchangeably.

8. The merchandising system of claim 1 further comprising a base for supporting the grid.

9. The merchandising system of claim 8 wherein the base comprises one or more vertical members.

10. The merchandising system of claim 9 further comprising brackets for coupling the grid to the one or more vertical members.

11. The merchandising system of claim 10 wherein the vertical members comprise apertures for engaging with the brackets.

12. The merchandising system of claim 1 further comprising a tray system for presenting and storing articles, wherein the tray system is coupled to the grid.

13. The merchandising system of claim 1 wherein the vertical members have a diameter of about 0.30 to 0.425 inches.

14. The merchandising system of claim 13 wherein the vertical members have a diameter of about 0.375 inches.

15. The merchandising system of claim 1 wherein the horizontal members have a diameter of about 0.285 to 0.35 inches.

16. The merchandising system of claim 15 wherein the horizontal members have a diameter of about 0.306 to about 0.312 inches.

17. The merchandising system of claim 1 further comprising a plurality of grids.

18. A merchandising system for supporting tray systems comprising:

a support assembly having vertical members and horizontal members and configured so that the tray systems may be attached at select locations; and

at least one member fixedly attached to the support assembly and configured to resist deformation of the support assembly.

19. The merchandising system of claim 18 wherein the at least one member is attached to the vertical members.

20. The merchandising system of claim 19 wherein the support assembly is configured to support the tray systems in a generally linear orientation.

21. The merchandising system of claim 20 wherein the support assembly is configured to support tray systems of different sizes interchangeably.

22. The merchandising system of claim 21 wherein the at least one member comprises one of the following structures: (a) a square tube, (b) an L-channel, (c) a C-channel, and (d) a U-channel.

23. The merchandising system of claim 22 further comprising a base for supporting the support assembly, the base comprising one or more vertical elements.

24. The merchandising system of claim 23 further comprising a plurality of tray systems coupled to the support assembly.

25. A merchandising system for storing and presenting products on a shelf or display case comprising:

means for supporting a plurality of tray systems at select locations; and

means for providing strength and rigidity to the merchandising system and configured to resist deformation of the means for supporting the plurality of tray systems.

26. A merchandising system for supporting products comprising:

a plurality of vertically oriented members;

a plurality of horizontally oriented members coupled to the vertically oriented members in a grid formation; and

frame members coupled to the vertically oriented members such that the grid formation resists deformation.

27. The merchandising system of claim 26 wherein the frame members comprise at least one of the following structures: (a) a square tube, (b) an L-channel, (c) a C-channel, and (d) a U-channel.

28. A merchandising system for presenting and storing articles comprising:

a frame comprising a plurality of generally horizontal members configured for attachment of a holder; and

at least one frame member provided to rigidify the plurality of horizontal members so that the frame is

resistant to deformation when the holder is attached to one or more of the plurality of horizontal members.

29. The merchandising system of claim 28 wherein the holder is removable.

30. The merchandising system of claim 29 wherein the holder is a tray system.

31. The merchandising system of claim 28 wherein the frame is configured for attachment of a holder by way of hooks.

32. The merchandising system of claim 28 wherein the frame further comprises a plurality of generally vertical members arranged in a grid with the plurality of horizontal members.

33. The merchandising system of claim 28 wherein the plurality of horizontal members are arranged in a grid.

34. The merchandising system of claim 33 wherein the plurality of horizontal members are arranged in a generally planar configuration.

* * * * *