



Europäisches Patentamt
European Patent Office
Office européen des brevets



(11) **EP 1 411 796 B1**

(12) **EUROPEAN PATENT SPECIFICATION**

(45) Date of publication and mention
of the grant of the patent:
29.03.2006 Bulletin 2006/13

(21) Application number: **02745636.7**

(22) Date of filing: **15.07.2002**

(51) Int Cl.:
A45D 19/00 (2006.01)

(86) International application number:
PCT/GB2002/003256

(87) International publication number:
WO 2003/011069 (13.02.2003 Gazette 2003/07)

(54) **METHOD AND APPARATUS FOR USE IN TREATING STRANDS OF HAIR**

VERFAHREN UND VORRICHTUNG ZUR BEHANDLUNG VON HAARSTRÄHNEN

PROCEDE ET APPAREIL S'UTILISANT DANS LE TRAITEMENT DE MECHES DE CHEVEUX

(84) Designated Contracting States:
**AT BE BG CH CY CZ DE DK EE ES FI FR GB GR
IE IT LI LU MC NL PT SE SK TR**

(30) Priority: **26.07.2001 GB 0118230
04.07.2002 GB 0215491**

(43) Date of publication of application:
28.04.2004 Bulletin 2004/18

(73) Proprietor: **De Benedictis, Danielle Anita
Luton,
Bedfordshire MK43 7RZ (GB)**

(72) Inventor: **De Benedictis, Danielle Anita
Luton,
Bedfordshire MK43 7RZ (GB)**

(74) Representative: **Bennett, Adrian Robert J. et al
A.A. Thornton & Co.
235 High Holborn
London WC1V 7LE (GB)**

(56) References cited:
**EP-A- 0 565 750 WO-A-94/23610
WO-A-97/38602 FR-A- 2 585 565
FR-A- 2 643 239 US-A- 3 408 705
US-A- 5 664 590**

EP 1 411 796 B1

Note: Within nine months from the publication of the mention of the grant of the European patent, any person may give notice to the European Patent Office of opposition to the European patent granted. Notice of opposition shall be filed in a written reasoned statement. It shall not be deemed to have been filed until the opposition fee has been paid. (Art. 99(1) European Patent Convention).

Description

[0001] The present invention relates to a method and apparatus for use in treating selected strands of hair and particularly, but not exclusively, to a method and apparatus for use in the colouring of selected strands of hair.

[0002] It is known to use lengths of flexible material for isolating selected strands of hair during a process of hair treatment such as colouring. Typically, strands of hair to be coloured are first selected by a hairdressing technique known as weaving. These strands of hair are then laid over a length of liquid impermeable material which effectively isolates the selected hair from the remaining hair. The barrier material will generally have a width of 2 or 3 inches (i.e. between 5 and 8 cm) and a length at least equal to that of the hair to be treated. One edge of the material is located adjacent the roots of the selected hair strands and in contact with the scalp. The hair roots are then pressed onto a portion of the material provided with a contact adhesive. The material is thereby retained in position on the scalp during the hair treatment process. With the material secured in place, an appropriate hair treatment substance may be applied to the selected strands of hair. The scalp and remaining hair strands are protected from exposure to the hair treatment substance by means of the barrier material.

[0003] Prior art documents WO 97/38602, and FR 2 585 565 disclose hair treatment apparatus comprising a substrate provided with a plurality of hook elements for gripping selected strands of hair and retaining the substrate in position. Once a hair treatment substance has been applied to the selected hair strands, the substrate is folded so as to encapsulate the selected hair strands and mask the hair strands from the remaining head of hair. However, the substrate is retained in the folded position by means of the inherent stiffness of the substrate material and/or by means of the surface tension of the hair treatment substance. A further prior art apparatus for the treatment of hair is disclosed in US 5,664,590. This further prior art apparatus comprises first and second substrates which overlie one another and are connected along one edge so as to be hingedly movable relative to one another. One surface of the first substrate is entirely covered with hook fasteners whilst a mating surface of the second substrate is entirely covered with loop fasteners which, in use, cooperate with the hook fasteners.

[0004] The present invention seeks to solve certain problems with the presently known hair treatment apparatus and process. Specifically, use of the prior art apparatus can be problematic since a practitioner will often cause the adhesive on the barrier material to contact surfaces (such as the scalp, the hair ends rather than the hair roots, or the barrier material itself) by mistake. Further use of the apparatus will require remedial action in order to free the barrier material from the surface to which it has been mistakenly attached. In certain circumstances, particularly where portions of the barrier material have

become attached to one another by means of the adhesive, subsequent use of the apparatus will not be possible and the apparatus will be disposed of without having been used. Even where further use of the apparatus is possible, the effectiveness of the contact adhesive will often have been reduced by its previous surface contact. The prior art apparatus can therefore lead to a time consuming and wasteful hair treatment process. In addition, the prior art apparatus do not tend to adhere effectively with greasy types of hair. As a result, it will very often be necessary to wash hair to be treated before use of the aforementioned prior art apparatus. Again, this leads to a time consuming process. Furthermore, the adhesive will of course only secure to the barrier material those strands of hair which it contacts. Thus, where a subject with dense hair is under treatment selected strands of hair will very often overlay further selected hair strands in contact with the adhesive and, accordingly, not themselves be secured to the barrier material. This can lead to an increased risk of hair treatment substance bleeding onto the scalp.

[0005] The problems with the prior art apparatus also include the difficulty of selecting a barrier material from a store of such materials. In the prior art, barrier materials are generally sold in cartons as tightly packed individual barrier materials. Thus, when a carton is opened, the user is presented with a plurality of barrier materials which are pressed closely together and not readily removable. During a hair treatment process, it is particularly desirable for barrier materials to be rapidly and conveniently selectable with a single hand. Since this is generally not possible with packaged barrier materials (particularly with a recently opened carton of such materials), it is frequently the case that the number of barrier materials required for a particular treatment will be first removed from a carton before commencement of the treatment so that the materials can be selected with a single hand during the treatment process. However, removal of the materials from the carton can lead to the materials becoming misplaced and is not conducive to good order.

[0006] A first aspect of the present invention provides apparatus for use in the treatment of selected strands of hair, the apparatus comprising a substrate of material for separating selected strands of hair of a head of hair from other hair strands of the head of hair while the selected hair strands are treated; and securing means provided on the substrate for securing the substrate to hair strands, said securing means comprising a first plurality of elements for hooking about and gripping one or more strands of hair; characterised in that said securing means further comprises a second plurality of elements for hooking about and gripping one or more strands of hair, the first and second plurality of elements being located on the substrate so as to be spaced from one another and releasably connectable with one another when, in use, the substrate is folded at a location between the first and second plurality of elements.

[0007] The first plurality of elements may be located

adjacent an edge of the substrate. The first plurality of elements is preferably located across the full width of the substrate. The number of elements per unit area may also vary across the substrate. The securing means is preferably manufactured using injection moulding techniques.

[0008] It is preferable for at least one of the elements of the first plurality of elements to comprise an elongate member defined by a groove in said apparatus. Ideally, said groove is straight. Opposite sides of said groove may each define an elongate member whereby said groove defines two elements for gripping one or more strands of hair. At least one of the elements of the first plurality of elements preferably comprises a head having a surface sloped so as to direct hair strands pressed thereagainst towards a position relative to said at least one element whereby said hair strands are gripped by said at least one element.

[0009] It is particularly desirable for at least one of the elements of the first plurality of elements to comprise a member extending outwardly from a surface at an acute angle to said surface so as to define a space between said member and said surface in which at least one strand of hair may locate in use. The junction of said member and said surface may have a closed loop shape. The closed loop shape may be substantially circular so as to define a space between said member and said surface having a substantially annular shape. The acute angle is preferably less than 45° and is preferably 30°.

[0010] At least one of the elements of the first plurality of elements may comprise a member extending perpendicular from a surface. The perpendicularly extending member may have a substantially cylindrical outer surface. At least one of the elements may comprise a member extending substantially parallel to said surface. The member extending substantially parallel to said surface may have a substantially annular shape.

[0011] The first plurality of elements is most preferably located on a portion of substrate surface extending part way along the length of the substrate. The first plurality of elements may also be located on a curved portion of substrate surface. Preferably, the first plurality of elements is provided integrally with a base portion manufactured separately from the substrate. The base portion may define a curved surface secured in abutment with the substrate. Said curved surface may be provided adjacent a leading edge of the base portion which, in use, is located against the scalp. An edge of the base portion is preferably free from the substrate so as to allow, in use, placement of a tool between the base portion and substrate. It is preferable for said free edge to be positioned so that, in use, a tool may locate in abutment with the junction between said free edge and the substrate and press an edge of the substrate against the scalp. Said free edge may be a trailing edge of the base portion opposite and parallel with the leading edge. The base portion may be secured in abutment with the substrate by means of an adhesive. Ideally, the base portion com-

prises means for restricting the flow of liquid across a surface of the base portion. The flow restricting means may comprise a groove in said surface of the base portion. The substrate may be of a flexible material and may also be of a transparent material.

[0012] It may also be desirable to provide a second plurality of elements on the substrate which are releasably connectable with the first plurality of elements when, in use, the substrate is folded about selected strands of hair. Said second plurality of elements may comprise fibres and/or a plurality of hooks. The fibres may be looped or have free ends. Also, these latter plurality of hooks may be provided as recited above in respect of the elements of the securing means.

[0013] A second aspect of the present invention provides a method of using the apparatus of the first aspect, the method comprising the steps of locating the substrate of the apparatus adjacent selected strands of hair of a head of hair; and pressing strands of hair against said securing means so as to locate at least one element of the first plurality of elements adjacent about at least one pressed strand of hair and thereby grip said at least one hair strand and secure the substrate in a position separating the selected strands of hair from other strands of hair. The strands of hair pressed against said securing means may be strands of hair selected for masking from other strands of hair.

[0014] The method may also further comprise the steps of folding the substrate about said selected strands of hair; and pressing at least one element of the second plurality of elements against said first plurality of elements so that the at least one element of the second plurality of elements and the first plurality of elements grip one another.

[0015] Apparatus may also be provided for use in the treatment of selected strands of hair, the apparatus comprising a substrate of material for separating selected strands of hair of a head of hair from other hair strands of the head of hair while the selected hair strands are treated; and securing means provided on the substrate for securing the substrate to hair strands; characterised in that the substrate is provided with a plurality of perforations arranged in a line, wherein each of said line is located adjacent an edge of the substrate.

[0016] Preferably, said line of perforations is located adjacent the securing means.

[0017] The line of perforations may extend across the width of the substrate from one longitudinally extending edge to an opposite longitudinally extending edge. The line of perforations preferably defines a common boundary of two portions of the substrate, one portion of substrate being provided with the securing means. The other of said portions of substrate may be provided with at least one aperture.

[0018] Apparatus may further be provided for use in the treatment of selected strands of hair, the apparatus comprising a plurality of the perforated apparatus mentioned above, wherein the other of said substrate portions

of the plurality of apparatus are connected to one another.

[0019] A method of using the perforated apparatus described above may also be provided, the method comprising the steps of tearing one portion of substrate from another portion of substrate along said line of perforations; locating a portion of substrate provided with securing means adjacent selected strands of hair of a head of hair, and securing said substrate portion adjacent said selected hair strands so as to separate said strands from other strands of hair.

[0020] Embodiments of the present invention will now be described with reference to the accompanying drawings, in which:

Figure 1 is a schematic top view of a first hair treatment apparatus;

Figure 2 is a schematic perspective view of a plurality of hooks provided in the arrangement of Figure 1;

Figure 3 is a schematic side view of a hook and loop connection wherein the hook is of the type shown in Figure 2;

Figure 4 is a schematic side view of a hook and hook connection in accordance with the present invention wherein the hooks are of the type shown in Figure 2;

Figure 5 is a schematic perspective view of a strip of hooked material provided in the arrangement of Figure 1;

Figure 6 is a schematic perspective view of an alternative strip of hooked material to that provided in the arrangement of Figure 1;

Figure 7 is a schematic cross-sectional side view of an upper portion of the first apparatus secured to a wicket dispenser;

Figure 8 is a schematic side view of an upper portion of a second apparatus provided with the hooked material shown in Figure 6;

Figure 9 is a schematic top view of a third apparatus which, when provided with hooked material at both upper and lower edges of the substrate, is an embodiment of the present invention;

Figure 10 is a schematic top view of a fourth apparatus which, when provided with hooked material at both upper and lower edges of the substrate, is an embodiment of the present invention;

Figure 11 is a schematic top view of a fifth apparatus which, when provided with hooked material at both upper and lower edges of the substrate, is an embodiment of the present invention;

Figure 12 is a schematic top view of a sixth apparatus which, when provided with hooked material at both upper and lower edges of the substrate, is an embodiment of the present invention;

Figure 13 is a schematic top partial view of a strip of hooked material comprising circular mushroom shaped hook members;

Figure 14 is a schematic partial cross-section side view of the hooked material of Figure 13 taken along line A-A of said Figure;

Figure 15 is a schematic partial cross-sectional side view of a modified version of the hooked material shown in Figure 13;

Figure 16 is a schematic top partial view of a strip of hooked material comprising elongate T-shaped hook members;

Figure 17 is a schematic partial cross-sectional side view of the hooked material of Figure 16 taken along line B-B of said Figure; and

Figure 18 is a schematic partial cross-sectional side view of a modified version of the hooked material shown in Figure 17.

[0021] A first hair treatment apparatus 2 is shown in Figure 1 of the accompanying drawings. The apparatus 2 comprises an elongate strip of flexible material which forms a base sheet 4 upon which a strip of hooked material 6 (described hereinafter) is mounted. The material of the base sheet 4 is impermeable to the hair treatment substances with which the apparatus 2 is to be used. Accordingly, the base sheet 4, forms an effective barrier between said hair treatment substances and strands of hair which are intended to be isolated from said substances. As well as having an impermeable characteristic, the material of the base sheet 4 is preferably also transparent so as to permit inspection of the strands of hair selected for treatment without the need to remove the apparatus 2 from the hair. The aforementioned characteristics of the base sheet 4 may be provided with a synthetic plastics material such as CELLOPHANE (RTM).

[0022] The base sheet 4 has an elongate rectangular shape. The particular apparatus 2 shown in Figure 1 has a width W of 75mm and an overall length L of 170mm. These dimensions may however be varied to suit specific circumstances.

[0023] In particular, the length L may be increased or decreased depending upon the length of hair to be treated. As will be evident to those skilled in the art, the apparatus 2 should be at least as long as the strands of hair undergoing treatment so as to ensure isolation of this hair from the surrounding hair. It is envisaged that embodiments of the present invention will be provided with base sheets having standard lengths of 200mm, 400mm and 500mm and standard widths of 75mm and 90mm.

[0024] An upper portion 8 of the base sheet 4 is provided with two circular apertures 10 located either side of the longitudinal axis 12 of the apparatus 2. As will be described hereinafter with reference to Figure 7, the apertures 10 allow the base sheet 4 to be mounted to the wicket of a supply device. The base sheet 4 is further provided with a line of perforations 14 extending perpendicularly to the longitudinal axis 12 across the width of the base sheet 4. The perforations 14 extend through the thickness of the base sheet 4 and, in use, allow the upper portion 8 of the base sheet 4 to be readily detached from the remainder of the base sheet 4.

[0025] The strip of hooked material 6 is rectangular in shape and extends across the full width of the base sheet

4. The hooked material 6 extends approximately 15mm along the length of the base sheet 4 and is securely attached to the aforementioned remainder portion of the base sheet 4 by means of a suitable adhesive. In an alternative apparatus, the strip of hooked material 6 may be formed integrally with the base sheet 4. An upper edge 16 (which locates adjacent the scalp when in use) of the hooked material 6 is located on the remainder portion of the base sheet 4 in line with the perforations 14. In further apparatus, said upper edge may locate above the line of perforations 14 so that part of the hooked material 6 overlaps the upper portion 8 of the base sheet 4: However, in this further alternative arrangement, the overlaying part of the hooked material 6 is not secured to the upper portion 8 by adhesive (or other means) so as to allow ready detachment of the upper portion 8 from the hooked material 6 and the remainder of the base sheet 4 during use.

[0026] The strip of hooked material 6 is formed with an inherently curved shape. The curved shape is preferably part circular. As shown in Figure 1, once the hooked material 6 is secured to the base sheet 4, the base sheet 4 (at least in the vicinity of the hooked material 6) adopts the curved profile of the hooked material 6. In use, the curvature of the upper edge 16 of the hooked material 6 ensures the base sheet 4 conforms more readily with the curvature of the scalp. To assist in ensuring conformity of the base sheet 4 with the scalp, at least the upper edge region of the hooked material 6 may be flexible (preferably resiliently flexible) so as to allow deformation of the upper edge into contact with the scalp across the full width of the base sheet 4. Indeed, the hooked material 6 may be planar (i. e. without a curved profile) provided it is flexible. As a result, the apparatus 2 may be applied more easily and is more comfortable to the person whose hair is undergoing treatment. The specific apparatus 2 shown in Figure 1 comprises a hooked material 6 having a curvature of 4.25cm radius, however other magnitudes of curvature may of course be used.

[0027] The outer curved surface 18 of the hooked material 6 grips the roots of selected strands of hair during use and is provided for this purpose with a plurality of small hooks (not shown in Figure 1). The hooks have a mushroom shape and are of the type typically used in hook and loop fabric fasteners. Other hook shapes used in hook and loop fasteners may however be provided on the curved surface 18. For example, a hook may comprise a member extending outwardly from the curved surface 18 at an acute angle to said surface so as to define a space between said member and said surface in which at least one strand of hair may locate in use. The acute angle is preferably 30°, although other angles may be used. A strand of hair to be gripped may be pressed between the member and surface in the direction of their convergence and thereby gripped by the member and surface. The hooks may have a frusto-conical shape so as to be capable of receiving and gripping one or more hair strands pressed towards the hooks from any direction along the surface of the hooked material 6.

[0028] With reference to Figure 2, it will be seen that a plurality of identical mushroom hooks 20 are uniformly distributed across the curved surface 18. However, in an alternative apparatus, the size and density of the hooks may vary across the surface 18. For example, it may be advantageous for the density (i.e. the number per unit area) of hooks to increase or decrease along the length of the base sheet 4. The density of hooks across the width of the base sheet 4 preferably does not vary. In this way, any given strip of hooked material 6 will be better able to effectively grip a variety of selected hair strands of different types (specifically, of different densities/thicknesses). With the hook density and shape varying along the length of the base sheet 4 (over the surface 18 of the hooked material 6) rather than across the width of the base sheet 4, adequate grip for all types of hair can be provided across the full width of the base sheet 4. However, in circumstances where the selected hair strands are of a type best gripped by hooks having a density and shape of those hooks 20 located adjacent the lower edge 22 of the surface 18 opposite the upper edge 16, the density and shape of the hooks located across the width of the base sheet 4 adjacent the upper edge 16 may be ineffective at gripping the selected hair strands. If this is considered undesirable due to a requirement to maintain the upper edge 16 secured to the selected hair strands and thereby retained against the scalp, then it is preferable to arrange the plurality of hooks 20 so that hook density and/or geometry varies across the width of the base sheet 4. In this way, at least some of the selected hair strands, at certain locations along the length of the upper edge 16, will be gripped so as to retain the entire length of the upper edge 16 against the scalp. Use of the plurality of hooks 20 in gripping selected strands of hair will be described in further detail hereinafter.

[0029] As most clearly seen in Figure 5 of the accompanying drawings, the curved surface 18 of the hooked material 6 is provided with a groove 24 extending along the upper edge 16. In use, the groove 24 acts as a gutter and provides resistance to liquid hair treatment substances which may attempt to flow from the aforementioned remainder portion of the base sheet 4, towards the upper edge 16, and onto the scalp. In an alternative strip of hooked material 6' as shown in Figure 6, the groove 24 is replaced by ridge 26 which extends upwardly from the surface 18' and extends along the upper edge 16'. In use, the ridge 16' acts as a barrier to fluid attempting to flow over the edge 16'. Although the strips of hooked material 6,6' shown in Figures 5 and 6 are illustrated as planar elements, said strips 6,6' are in practice formed so as to assume a curved profile (preferably having a circular shape) when in a relaxed state. As indicated above, the curvature of the strips 6,6' is such as the upper edges 16,16' are curved so as to allow conformity of said edges 16,16' with the scalp of a person undergoing treatment.

[0030] The base sheet 4 is further provided with a fold 28 extending perpendicularly to the longitudinal axis 12 across the width of the base sheet 4. The fold is located

midway between the upper edge 16 and a lower edge 30 of the base sheet 4. The fold 28 may be provided at an alternative location however. It is preferable for the fold 28 to be located so that the lower edge 30 may be folded, in use, onto the upper edge 16 so as to completely encapsulate the selected strands of hair. Alternatively, the fold 28 may be omitted and provided by a user as and when required

[0031] With reference to Figure 7, the apparatus 2 is shown mounted to the wicket 32 of a supply device 34. The wicket 32 is a U-shaped bar of circular cross-section. The wicket 32 may be manufactured from any suitable material such as a metal or a plastics material. The two free ends 36 (only one of which is visible in Figure 7) of the wicket 32 are spaced from one another by the same distance separating the apertures 10 provided in the base sheet 4. Also, the diameter of the wicket 32 circular cross-section is substantially equal to the diameter of the apertures 10 so as to allow one free end 36 to pass through one aperture 10 and the other free end 36 to pass through the other aperture 10. The wicket 32 thereby serves as a fixing to which one or more base sheets 4 may be mounted. Although not illustrated in Figure 7, a plurality of apparatus 2 are preferably mounted to the wicket 32. For example, twenty, thirty or forty base sheets 4 may be mounted to the wicket 32. The apparatus so mounted may be identical to one another or vary in size or design. In this latter regard, the plurality of apparatus may include apparatus having differing lengths, widths and/or differing designs of hooked material (as previously described for example).

[0032] Once the wicket 32 has been supplied with the required apparatus, the free ends 36 of the wicket 32 are received in a base member 38 of the supply device 34. The plurality of apparatus 2 are thereby prevented from sliding from the wicket 32. In practice, a plurality of apparatus 2 may be sold to a user pre-mounted to the wicket 32. The wicket 32 may then be realisably secured to a base member 38 already installed at the user's workplace. Alternatively, the plurality of apparatus 2 may be supplied with a supply device in its entirety. In these circumstances, the base member 38 of the supply device 34 may be provided with suitable fixings allowing the base member 38 to be realisably mounted to a wall in a rapid and convenient manner, for example, the rear face 40 of the base member 38 may be provided with apertures for engaging hook members mounted in a wall.

[0033] It will be understood that use of the supply device 34 allows convenient selection of a required apparatus 2. A plurality of apparatus 2 may be arranged on the wicket 32 in an ordered manner and this assists the user in grasping a particular apparatus 2 for use in isolating selected strands of hair. The user selects the required apparatus 2 by grasping the aforementioned remainder portion of base sheet 4 below the line of perforations 14. The remainder portion of base sheet 4 is then pulled along the wicket 32 and away from the base member 38 in the direction of arrow 42 (see Figure 7). The

upper portion 8 is however prevented from being removed from the wicket 32 by means of a cross-bar portion 44 (shown in dotted outline in Figure 7) of the wicket 32. Nevertheless, although the upper portion 8 is prevented from being removed, the line of perforations 14 extending across the width of the base sheet 4 allows the remainder portion of the base sheet 4 to be readily detached from the upper portion 8. Thus, the portion of an apparatus 2 required for the isolation of selected hair strands (i.e. the remainder portion of base sheet 4 provided with the strip of hooked material 6) may be readily selected for use. Although the upper portion 8 of a selected apparatus 2 remains on the wicket 32, this does not prevent the ready selection of further apparatus 2. The upper portion 8' of a selected apparatus previously torn from the wicket 32 is shown in Figure 7.

[0034] Once the required strands of hair have been selected (typically by means of a technique known as weaving) and a required apparatus 2 torn from the wicket 32, the remainder portion of the base sheet 4 is placed under the selected hair strands with the upper edge 16 pressed against the scalp and adjacent the root ends of the selected strands. The selected strands are then lightly pressed and massaged against the curved surface 18 of the hooked material 6. The selected strands of hair are thereby pressed between adjacent mushroom hooks 20 extending from the surface 18 and thereby tend to locate between the head of the hooks 20 and the surface 18. Hair overlaying the full width and length of the hooked material 6 is massaged (with, for example, the thumb of the user) so that the mushroom hooks 20 locate around the hair strands so as to grip said strands and ensure that the upper edge 16 is retained adjacent the scalp. The engagement of the hooks 20 with the selected hair strands also serves to resist lateral movement of the base sheet 4 during the hair treatment process.

[0035] The effectiveness of the hooks 20 in gripping selected hair strands is substantially independent of whether or not the hair strands have been recently washed. The hooks 20 tend to grip greasy hair with essentially the same effectiveness as when gripping non-greasy hair. The hooks 20 may also be disengaged from hair strands and reapplied without loss of grip effectiveness. Errors in the positioning of the upper edge 16 may therefore be readily corrected without the need for use of further apparatus 2. Ease of use is also facilitated by the hooks 20 in that said hooks 20 tend to adhere only to surfaces comprising fibres about which the hooks 20 may locate. The hooks 20 will not therefore tend to adhere to the remainder portion of the base sheet 4 or to the skin of a subject undergoing treatment.

[0036] With the upper edge 16 located in the desired position on the scalp, the selected strands of hair are laid so as to extend over the remainder portion of base sheet 4. Thus, it will be apparent that the remainder portion of the base sheet 4 functions to isolate the selected strands of hair from other hair located below the remainder portion and is effective to mask said other hair from exposure

to treatment substances applied to said selected strands of hair. An appropriate hair treatment substance such as a colouring liquid may be conveniently applied to selected strands of hair by means of a brush. It will be apparent to the skilled reader that the groove 24 functions to prevent hair treatment substance flowing from the hooked material 6 onto the scalp.

[0037] Once the hair treatment substance has been applied, the selected strands of hair are covered by folding the remainder portion of base sheet 4 along the fold line 28 so that the lower edge 30 locates adjacent the upper edge 16. Alternatively, the selected hair strands may be covered with a cover sheet separate to the remainder portion of base sheet 4. The lower edge 30 may be secured to the upper edge 16 with an adhesive, however it is preferable for a portion of the base sheet 4 adjacent the lower edge 30 to be provided with a material which may be gripped by the plurality with hooks 20 provided on the curved surface 18. The material may be a fibrous material comprising a plurality of loops 46 as conventionally used in hook and loop type fasteners (see Figure 3). Alternatively, and in accordance with the present invention, the material may comprise a further plurality of hooks 48 which are preferably of the mushroom type (see Figure 4).

[0038] When the lower edge 30 is secured adjacent the upper edge 16 (or a separate cover sheet is being located in place), the selected hair is encased and sealed from the immediate surroundings.

[0039] The apparatus 2 may be modified by replacing the grooved strip of hooked material 6 as shown in Figure 5 with the ridged strip of hooked material 6' as shown in Figure 6. A partial side view of the resultant apparatus 2' is shown in Figure 8. Further alternative apparatus 102, 202 are shown in Figures 9 and 10 respectively. These alternative apparatus 102, 202 differ from the apparatus 2 shown in Figure 1 only in that a strip of fibrous material 104 is provided on the base sheet 4 in the apparatus 102 of Figure 9 and two portions 204, 206 of fibrous material are provided on the base sheet 4 of the apparatus 202 shown in Figure 10. Elements of the further apparatus 102, 202 common with the apparatus 2 shown in Figure 1 are identified with like reference numerals.

[0040] As can be seen in Figure 9, the strip of fibrous material 104 is located adjacent the lower edge 30 of the base sheet 4 and extends across the full width of the base sheet 4. When the base sheet 4 is folded along fold line 28, the fibrous strip 104 mates with the strip of hooked material 6 so as to secure the lower edge 30 adjacent the upper edge 16. As will be seen from Figure 10, the two portions of fibrous material 204, 206 of apparatus 202 are square in shape and are located adjacent the lower edge 30 and opposite longitudinally extending edges 208, 210 of the base sheet 4. Thus, when the remainder portion of the base sheet 4 is folded along fold line 28, the fibrous portions 204, 206 serve to retain the lower edge 30 adjacent the upper edge 16 by engaging with

the hooks 20 of the hooked material 6.

[0041] Alternative arrangements of hook and loop, or, in accordance with the present invention, hook and hook, fastening will be apparent to the skilled reader. For example, hook and loop fastening material may be provided around the entire perimeter of the remainder portion of the base sheet 4 (i.e. along the length of the longitudinally extending edges of the base sheet 4 as well as the lower edge 30 of the base sheet 4). In this way, when the remainder portion of the base sheet 4 is folded along the fold line 28, selected strands of hair may be completely encapsulated and sealed between the material of the base sheet 4.

[0042] A yet further alternative arrangement is shown in Figure 11 of the accompanying drawings. The apparatus 302 of Figure 11 differs from the apparatus 2 of Figure 1 only in that a strip of fibrous material 304 is provided adjacent the lower edge 30 on the side of the base sheet 4 opposite to that on which the hooked material 6 is provided and in that the strip of hooked material 6 has a portion 306 which extends laterally of the base sheet 4. The fibrous material 304 extends across the full width of the base sheet 4. Also, the extended portion 306 of hooked material 6 has a length substantially equal to the width of the base sheet 4. In use of the apparatus 302, the base sheet 4 is folded along fold line 28 so that the lower edge 30 locates adjacent the upper edge 16. The lower edge 30 is then secured in place by folding the extended portion 306 of hooked material 6 onto the fibrous material 304. The extended portion 306 is folded at the edge of the base sheet 4 along a pre-formed fold line 308. The hooks provided on the extended portion 306 are thereby engaged with the fibrous material 304 and prevent substantial movement of the lower edge 30 from the upper edge 16. In a further variation, extended portions of hooked material 6 may extend from both longitudinally extending edges of the base sheet 4. Preferably, the two portions have lengths substantially equal to half the width of the base sheet 4.

[0043] The aforementioned fibrous material may comprise a plurality of loops for engaging hook members as is known in conventional hook and loop type fasteners. The fibrous material may also be provided as a cloth or absorbent paper material. In embodiments of the present invention, the fibrous material may be substituted with hooked material so that hook to hook connections are made rather than hook to loop connections. Hook to hook connections are particularly secure when mushroom-shaped hooks are employed as shown in Figure 4 of the accompanying drawings.

[0044] Furthermore, in order to ensure a portion of substrate with hooks provides a connection of uniform strength across said portion with hair strands and/or hooks/loops of varying types, more than one hook type (i.e. hook geometry and/or density) may be uniformly distributed across said portion. Any given hook member may therefore then be located next to a hook member of a different type.

[0045] In still further variations, the function of the hook and loop or hook and hook fasteners in securing portions of base sheet together (or a separate cover portion to the base sheet) can be performed by a tongue and groove arrangement, wherein a tongue extending from one portion is received and gripped by a groove in another portion.

[0046] A yet further apparatus 400 will now be described with reference to Figures 12 to 18 of the accompanying drawings. This further apparatus 400 is similar to the previously described arrangements in that it comprises an elongate strip of flexible material which forms a base sheet 404 upon which a strip of hooked material 406 is mounted. The material of the base sheet 404 is impermeable to the hair treatment substances with which the apparatus 400 is to be used. Accordingly, the base sheet 404 forms an effective barrier between said hair treatment substances and the strands of hair which are intended to be isolated from said substances. The strip of hooked material extends across the full width of the base sheet 404 and is securely attached along an upper edge thereof by means of a suitable adhesive. The dimensions of the base sheet 404 and hooked material 406 as are earlier described in relation to the previous embodiments and other arrangements. Between 2mm and 4mm of the lower edge 407 of the hooked material 406 is free and unadhered to the base sheet 404. The purpose of this feature is to allow the tail of a comb or the finger nail of a user to locate between the hooked material 406 and the base sheet 404 in the region of the lower edge 407 so as to allow the upper edge 409 of the base sheet 404 to be pressed, in use, against the scalp. The portion of hooked material 406 adhered to the base sheet 404 is that portion of hooked material 406 located between the upper edge 409 of the base sheet 404 and dotted line 410 shown in Figure 12. It will be apparent to the skilled reader that this feature can be employed on any of the previously described embodiments and other arrangements.

[0047] As in the arrangement of Figure 9, a strip of fibrous, or, in accordance with the present invention, hooked, material 411 is secured by means of a suitable adhesive adjacent the lower edge 413 of the base sheet 404. Thus, when the base sheet 404 is folded in use and the lower edge 413 is closed adjacent the upper edge 409, the lower strip of material 411 will engage the upper strip of material 406 and become connected therewith. This connection not only assists in retaining the base sheet 404 in a folded position, but also assists in preventing hair treatment substances from undesirably leaking onto the scalp. When a fibrous material is used in any of the arrangements described herein, the fibres of said material may be looped or, ideally, have a free end.

[0048] A partial plan view of the strip of hooked material 406 is shown in Figure 13 of the accompanying drawings. The enlarged view of Figure 13 shows that the hooked material 406 is provided with a plurality of circular mushroom shaped hook members 414. The hook members

414 are arranged in a plurality of columns which run parallel to the longitudinal axis 415 of the base sheet 404. As a result, strands of hair may locate between columns of hook members 414 without being bent or kinked. In other words; strands of hair may assume a straight form whilst lying between adjacent columns of hook members 414.

[0049] As shown in the cross-sectional side view of Figure 14, the head 416 of each hook member 414 has a flat planar upper surface 417. However, in a modified version of the hooked material 406 as shown in Figure 15, each hook member 414 has a head 416 with a conical upper surface 418. As yet a further alternative, the upper surface may be part spherical as shown in Figures 3 and 4. The use of a curved or otherwise sloping upper surface assists in locating hair strands between the hook members 414. In this regard, said upper surfaces 418 of the hook members 414 serve to guide hair strands towards the gap between the hook members 414.

[0050] The strip of hooked material 406 shown in Figures 13 to 15 may be substituted with the further modified strips of hooked material shown in Figures 16 to 18 of the accompanying drawings. The hooked material shown in Figures 16 to 18 comprises a plurality of elongate T-shaped hooks 420. The formation of the hook members 420 is such that an elongate T-shaped groove 422 is formed between adjacent hook members 420 which extends parallel to the longitudinal axis 415 of the base sheet 404 and extends from an upper edge 423 of the hooked material to a lower edge 424 thereof. Since the grooves 422 are straight, strands of hair may be retained in a straight form between adjacent elongate hooks 420. As shown in Figure 18, the heads of the hook members 420 have been provided with sloping upper surfaces 423 for guiding hair strands towards a groove 422.

[0051] In order for the lower strip of material 411 to connect with a strip of hooked material 406 comprising the elongate hook members 420 shown in Figures 16 to 18, the lower strip of material should preferably be provided with a plurality of hook members in accordance with the present invention (for example, mushroom shaped hooks or elongate T-shaped hooks). Such hook members are more likely to securely connect with the elongate T-shaped hook members of the hooked material than loops or other fibrous material.

[0052] The present invention is not limited to the specific embodiment described above. Alternative arrangements and suitable materials will be apparent to a reader skilled in the art.

Claims

1. Apparatus (102) for use in the treatment of selected strands of hair, the apparatus comprising a substrate (4) of material for separating selected strands of hair of a head of hair from other hair strands of the head of hair while the selected hair strands are treated;

- and securing means provided on the substrate (4) for securing the substrate (4) to hair strands, said securing means comprising a first plurality of elements (6) for hooking about and gripping one or more strands of hair; **characterised in that** said securing means further comprises a second plurality of elements (104) for hooking about and gripping one or more strands of hair, the first and second plurality of elements (6,104) being located on the substrate so as to be spaced from one another and releasably connectable with one another when, in use, the substrate is folded at a location (102) between the first and second plurality of elements.
2. Apparatus as claimed in claim 1, wherein the first plurality of elements (6) is located adjacent an edge (16) of the substrate (4).
 3. Apparatus as claimed in claim 1 or 2, wherein the first plurality of elements (6) is located across the full width of the substrate.
 4. Apparatus as claimed in any preceding claim, wherein the number of elements per unit area varies across the substrate (4).
 5. Apparatus as claimed in any preceding claim, wherein at least one of the elements of the first plurality of elements (6) comprises an elongate member defined by a groove (422) in said apparatus.
 6. Apparatus as claimed in claim 5, wherein said groove (422) is straight.
 7. Apparatus as claimed in claim 5 or 6, wherein opposite sides of said groove (422) each define an elongate member whereby said groove defines two elements (420) for gripping one or more strands of hair.
 8. Apparatus as claimed in any preceding claim, wherein at least one of the elements of the first or second plurality of elements (6,104) comprises a head having a surface sloped so as to direct hair strands pressed thereagainst towards a position relative to said at least one element whereby said hair strands are gripped by said at least one element.
 9. Apparatus as claimed in any preceding claim, wherein at least one of the elements of the first or second plurality of elements (6,104) comprises a member extending outwardly from a surface at an acute angle to said surface so as to define a space between said member and said surface in which at least one strand of hair may locate in use.
 10. Apparatus as claimed in claim 9, wherein the junction of said member and said surface has a closed loop shape.
 11. Apparatus as claimed in claim 10, wherein said closed loop shape is substantially circular so as to define a space between said member and said surface having a substantially annular shape.
 12. Apparatus as claimed in any of claims 9 to 11, wherein said acute angle is less than 45°.
 13. Apparatus as claimed in claim 12, wherein said acute angle is 30°.
 14. Apparatus as claimed in any of claims 1 to 4, wherein at least one of the elements of the first or second plurality of elements (6,104) comprises a member extending perpendicularly from a surface wherein the perpendicularly extending member has a substantially cylindrical outer surface.
 15. Apparatus as claimed in any of claims 9 to 14, wherein said at least one of the elements comprises a member extending substantially parallel to said surface.
 16. Apparatus as claimed in claim 15, wherein said member extending substantially parallel to said surface has a substantially annular shape.
 17. Apparatus as claimed in any preceding claim, wherein the first plurality of elements (6) is located on a portion of substrate surface extending part way along the length of the substrate (4).
 18. Apparatus as claimed in any preceding claim, wherein the first plurality of elements (6) is located on a curved portion of substrate surface.
 19. Apparatus as claimed in any preceding claim, wherein the first plurality of elements is provided integrally with a base portion manufactured separately from the substrate (4).
 20. Apparatus as claimed in claim 19, wherein the base portion defines a curved surface secured in abutment with the substrate (4).
 21. Apparatus as claimed in claim 19 or 20, wherein an edge of the base portion is free from the substrate so as to allow, in use, placement of a tool between the base portion and substrate.
 22. Apparatus as claimed in claim 21, wherein said free edge is positioned so that, in use, a tool may locate between said free edge and the substrate and press an edge of the substrate against a scalp.
 23. Apparatus as claimed in any of claims 19 to 22, wherein the base portion is secured in abutment with the substrate by means of an adhesive.

24. Apparatus as claimed in any of claims 19 to 23, wherein the base portion comprises means for restricting a flow of liquid across a surface (18) of the base portion.
25. Apparatus as claimed in claim 24, wherein said flow restricting means comprises a groove (24) in said surface of the base portion.
26. Apparatus as claimed in any preceding claim, wherein the substrate (4) is of a flexible material.
27. Apparatus as claimed in any preceding claim, wherein the substrate (4) is of a transparent material.
28. A method of using the apparatus (102) claimed in any of the preceding claims, the method comprising the steps of locating the substrate (4) of the apparatus (102) adjacent selected strands of hair of a head of hair; and pressing strands of hair against said securing means so as to locate at least one element of the first plurality of elements (6) adjacent at least one pressed strand of hair and thereby grip said at least one hair strand and secure the substrate in a position separating the selected strands of hair from other strands of hair.
29. A method as claimed in claim 28, further comprising the steps of folding the substrate (4) about said selected strands of hair; and pressing at least one element of the second plurality of elements (104) against said first plurality of elements (6) so that the at least one element of the second plurality of elements (104) and the first plurality of elements grip one another.

Revendications

1. Appareil (102) destiné à être utilisé dans le traitement de mèches sélectionnées de cheveux, l'appareil comprenant un substrat (4) de matériau pour la séparation de mèches sélectionnées de cheveux d'une tête de cheveux d'autres mèches de cheveux de la tête de cheveux tandis que les mèches de cheveux sélectionnées sont traitées ; et des moyens de fixation prévus sur le substrat (4) pour la fixation du substrat (4) à des mèches de cheveux, lesdits moyens de fixation comprenant une première pluralité d'éléments (6) pour l'accrochage autour et la saisie d'une ou de plusieurs mèches de cheveux ; **caractérisé en ce que** lesdits moyens de fixation comprennent en outre une seconde pluralité d'éléments (104) pour l'accrochage autour et la saisie d'une ou de plusieurs mèches de cheveux, la première et la seconde pluralité d'éléments (6, 104) étant situées sur le substrat de manière à être espacées l'une de l'autre et à pouvoir être connectées de manière dé-

tachable l'une à l'autre lorsque le substrat est plié à un endroit (102) entre la première et la seconde pluralité d'éléments lors de son utilisation.

2. Appareil selon la revendication 1, dans lequel la première pluralité d'éléments (6) est située de manière adjacente à un bord (16) du substrat (4).
3. Appareil selon la revendication 1 ou 2, dans lequel la première pluralité d'éléments (6) est située sur l'ensemble de la largeur du substrat.
4. Appareil selon l'une quelconque des revendications précédentes, dans lequel le nombre d'éléments par surface unitaire varie sur l'ensemble du substrat (4).
5. Appareil selon l'une quelconque des revendications précédentes, dans lequel au moins un des éléments de la première pluralité d'éléments (6) comprend un membre allongé défini par une rainure (422) dans ledit appareil.
6. Appareil selon la revendication 5, dans lequel ladite rainure (422) est droite.
7. Appareil selon la revendication 5 ou 6, dans lequel des côtés opposés de ladite rainure (422) définissent chacun un membre allongé, moyennant quoi ladite rainure définit deux éléments (420) pour la saisie d'une ou de plusieurs mèches de cheveux.
8. Appareil selon l'une quelconque des revendications précédentes, dans lequel au moins un des éléments de la première ou seconde pluralité d'éléments (6, 104) comprend une tête ayant une surface en pente de manière à diriger des mèches de cheveux pressées contre elle vers une position par rapport audit au moins un élément, moyennant quoi lesdites mèches de cheveux sont saisies par ledit au moins un élément.
9. Appareil selon l'une quelconque des revendications précédentes, dans lequel au moins un des éléments de la première ou seconde pluralité d'éléments (6, 104) comprend un membre s'étendant vers l'extérieur depuis une surface à un angle aigu vers ladite surface de manière à définir un espace entre ledit membre et ladite surface dans lequel au moins une mèche de cheveux peut être située lors de son utilisation.
10. Appareil selon la revendication 9, dans lequel la jonction dudit membre et de ladite surface possède une forme de boucle fermée.
11. Appareil selon la revendication 10, dans lequel ladite forme de boucle fermée est essentiellement circulaire de manière à définir un espace entre ledit mem-

- bre et ladite surface ayant une forme essentiellement annulaire.
12. Appareil selon l'une quelconque des revendications 9 à 11, dans lequel ledit angle aigu est inférieur à 45°.
13. Appareil selon la revendication 12, dans lequel ledit angle aigu est de 30°.
14. Appareil selon l'une quelconque des revendications 1 à 4, dans lequel au moins un des éléments de la première ou seconde pluralité d'éléments (6, 104) comprend un membre s'étendant perpendiculairement depuis une surface, dans lequel le membre s'étendant perpendiculairement possède une surface externe essentiellement cylindrique
15. Appareil selon l'une quelconque des revendications 9 à 14, dans lequel au moins un des éléments comprend un membre s'étendant essentiellement parallèlement à ladite surface.
16. Appareil selon la revendication 15, dans lequel ledit membre s'étendant essentiellement parallèlement à ladite surface possède une forme essentiellement annulaire.
17. Appareil selon l'une quelconque des revendications précédentes, dans lequel la première pluralité d'éléments (6) est située sur une portion de surface du substrat s'étendant à mi-chemin le long de la longueur du substrat (4).
18. Appareil selon l'une quelconque des revendications précédentes, dans lequel la première pluralité d'éléments (6) est située sur une portion courbe de la surface du substrat.
19. Appareil selon l'une quelconque des revendications précédentes, dans lequel la première pluralité d'éléments est pourvue de manière intégrale d'une portion de base fabriquée séparément du substrat (4).
20. Appareil selon la revendication 19, dans lequel la portion de base définit une surface courbe fixée en butée avec le substrat (4).
21. Appareil selon la revendication 19 ou 20, dans lequel un bord de la portion de base est libre du substrat de manière à permettre, lors de son utilisation, le placement d'un outil entre la portion de base et le substrat
22. Appareil selon la revendication 21, dans lequel ledit bord libre est positionné de sorte que, lors de son utilisation, un outil peut se situer entre ledit bord libre et le substrat et presser un bord du substrat contre un cuir chevelu.
23. Appareil selon l'une quelconque des revendications 19 à 22, dans lequel la portion de base est fixée en butée avec le substrat au moyen d'un adhésif.
24. Appareil selon l'une quelconque des revendications 19 à 23, dans lequel la portion de base comprend des moyens pour la restriction d'un flux de liquide sur l'ensemble d'une surface (18) de la portion de base.
25. Appareil selon la revendication 24, dans lequel lesdits moyens de restriction de flux comprennent une rainure (24) dans ladite surface de la portion de base.
26. Appareil selon l'une quelconque des revendications précédentes, dans lequel le substrat (4) est constitué d'un matériau flexible.
27. Appareil selon l'une quelconque des revendications précédentes, dans lequel le substrat (4) est constitué d'un matériau transparent.
28. Procédé d'utilisation de l'appareil (102) selon l'une quelconque des revendications précédentes, le procédé comprenant les étapes consistant à placer le substrat (4) de l'appareil (102) de manière adjacente à des mèches sélectionnées de cheveux d'une tête de cheveux ; et presser des mèches de cheveux contre lesdits moyens de fixation de manière à placer au moins un élément de la première pluralité d'éléments (6) de manière adjacente à au moins une mèche pressée de cheveux et ainsi saisir ladite au moins une mèche de cheveux et fixer le substrat dans une position séparant les mèches sélectionnées de cheveux d'autres mèches de cheveux.
29. Procédé selon la revendication 28, comprenant en outre les étapes consistant à plier le substrat (4) autour desdites mèches sélectionnées de cheveux ; et presser au moins un élément de la seconde pluralité d'éléments (104) contre ladite première pluralité d'éléments (6) de sorte que l'au moins un élément de la seconde pluralité d'éléments (104) et de la première pluralité d'éléments s'agrippent.

Patentansprüche

1. Vorrichtung (102) zur Verwendung bei der Behandlung von ausgewählten Haarsträhnen, wobei die Vorrichtung einen Träger (4) aus Material zum Trennen ausgewählter Haarsträhnen eines Haarschopfes von anderen Haarsträhnen des Haarschopfes, während die ausgewählten Haarsträhnen behandelt werden, und ein auf dem Träger (4) bereitgestelltes Befestigungsmittel zum Befestigen des Trägers (4) an Haarsträhnen umfasst, wobei das genannte Befestigungsmittel eine erste Mehrzahl von Teilen (6)

- zum Verhaken an und Festhalten von einer oder mehreren Haarsträhnen umfasst, **dadurch gekennzeichnet, dass** das genannte Befestigungsmittel ferner eine zweite Mehrzahl von Teilen (104) zum Verhaken an und Festhalten von einer oder mehreren Haarsträhnen umfasst, wobei die erste und die zweite Mehrzahl von Teilen (6, 104) so auf dem Träger angeordnet sind, dass sie voneinander beabstandet sind und lösbar miteinander verbunden werden können, wenn der Träger im Gebrauch an einer Stelle (102) zwischen der ersten und der zweiten Mehrzahl von Teilen gefaltet wird.
2. Vorrichtung nach Anspruch 1, bei der sich die erste Mehrzahl von Teilen (6) neben einem Rand (16) des Trägers (4) befindet.
 3. Vorrichtung nach Anspruch 1 oder 2, bei der die erste Mehrzahl von Teilen (6) über die volle Breite des Trägers angeordnet ist.
 4. Vorrichtung nach einem der vorhergehenden Ansprüche, bei der die Anzahl von Teilen pro Flächeneinheit über den Träger (4) variiert.
 5. Vorrichtung nach einem der vorhergehenden Ansprüche, bei der wenigstens eines der Teile der ersten Mehrzahl von Teilen (6) ein längliches Element umfasst, das von einer Nut (422) in der genannten Vorrichtung definiert wird.
 6. Vorrichtung nach Anspruch 5, bei der die genannte Nut (422) gerade ist.
 7. Vorrichtung nach Anspruch 5 oder 6, bei der einander entgegengesetzte Seiten der genannten Nut (422) jeweils ein längliches Element definieren, wodurch die genannte Nut zwei Teile (420) zum Festhalten von einer oder mehreren Haarsträhnen definiert.
 8. Vorrichtung nach einem der vorhergehenden Ansprüche, bei der wenigstens eines der Teile der ersten oder der zweiten Mehrzahl von Teilen (6, 104) einen Kopf umfasst, der eine Oberfläche hat, die so geneigt ist, dass sie daran gepresste Haarsträhnen in Richtung auf eine zu dem genannten wenigstens einen Teil relative Position lenkt, wodurch die genannten Haarsträhnen von dem genannten wenigstens einen Teil festgehalten werden.
 9. Vorrichtung nach einem der vorhergehenden Ansprüche, bei der wenigstens eines der Teile der ersten oder der zweiten Mehrzahl von Teilen (6, 104) ein Element umfasst, das sich von einer Oberfläche in einem spitzen Winkel zu der genannten Oberfläche auswärts erstreckt, um einen Zwischenraum zwischen dem genannten Element und der genannten Oberfläche zu definieren, in dem im Gebrauch wenigstens eine Haarsträhne zu liegen kommen kann.
- 5 10. Vorrichtung nach Anspruch 9, bei der die Verbindungsstelle des genannten Elements und der genannten Oberfläche eine geschlossenschleifige Form hat.
 - 10 11. Vorrichtung nach Anspruch 10, bei der die genannte geschlossenschleifige Form im wesentlichen kreisförmig ist, um einen Zwischenraum zwischen dem genannten Element und der genannten Oberfläche mit einer im Wesentlichen ringförmigen Form zu definieren.
 - 15 12. Vorrichtung nach einem der Ansprüche 9 bis 11, bei der der genannte spitze Winkel kleiner als 45° ist.
 - 20 13. Vorrichtung nach Anspruch 12, bei der der genannte spitze Winkel 30° beträgt.
 - 25 14. Vorrichtung nach einem der Ansprüche 1 bis 4, bei der wenigstens eines der Teile der ersten oder der zweiten Mehrzahl von Teilen (6, 104) ein Element umfasst, das sich lotrecht von einer Oberfläche erstreckt, wobei das sich lotrecht erstreckende Element eine im Wesentlichen zylindrische äußere Oberfläche hat.
 - 30 15. Vorrichtung nach einem der Ansprüche 9 bis 14, bei der das genannte wenigstens eine der Teile ein im Wesentlichen parallel zu der genannten Oberfläche verlaufendes Element umfasst.
 - 35 16. Vorrichtung nach Anspruch 15, bei der das genannte im Wesentlichen parallel zu der genannten Oberfläche verlaufende Teil eine im Wesentlichen ringförmige Form hat.
 - 40 17. Vorrichtung nach einem der vorhergehenden Ansprüche, bei der sich die erste Mehrzahl von Teilen (6) an einem Trägeroberflächenabschnitt befindet, der teilweise entlang der Länge des Trägers (4) verläuft.
 - 45 18. Vorrichtung nach einem der vorhergehenden Ansprüche, bei der sich die erste Mehrzahl von Teilen (6) an einem gekrümmten Abschnitt der Trägeroberfläche befindet.
 - 50 19. Vorrichtung nach einem der vorhergehenden Ansprüche, bei der die erste Mehrzahl von Teilen einstückig mit einem Basisabschnitt versehen ist, der von dem Träger (4) separat hergestellt wurde.
 - 55 20. Vorrichtung nach Anspruch 19, bei der der Basisabschnitt eine gekrümmte Oberfläche definiert, die an

dem Träger (4) in Anlage ist.

21. Vorrichtung nach Anspruch 19 oder 20, bei der ein Rand des Basisabschnitts frei von dem Träger ist, um im Gebrauch das Einsetzen eines Werkzeugs zwischen dem Basisabschnitt und dem Träger zu erlauben. 5
22. Vorrichtung nach Anspruch 21, bei der der genannte freie Rand so positioniert ist, dass im Gebrauch ein Werkzeug zwischen dem genannten freien Rand und dem Träger angeordnet sein und einen Rand des Trägers an eine Kopfhaut anpressen kann. 10
23. Vorrichtung nach einem der Ansprüche 19 bis 22, bei der der Basisabschnitt mithilfe eines Klebstoffs in Anlage an dem Träger befestigt ist. 15
24. Vorrichtung nach einem der Ansprüche 19 bis 23, bei der der Basisabschnitt ein Mittel zum Drosseln eines Flüssigkeitsstroms über eine Oberfläche (18) des Basisabschnitts aufweist. 20
25. Vorrichtung nach Anspruch 24, bei der das genannte stromdrosselnde Mittel eine Nut (24) in der genannten Oberfläche des Basisabschnitts umfasst. 25
26. Vorrichtung nach einem der vorhergehenden Ansprüche, bei der der Träger (4) aus einem flexiblen Material ist. 30
27. Vorrichtung nach einem der vorhergehenden Ansprüche, bei der der Träger (4) aus einem transparenten Material ist. 35
28. Verfahren zum Benutzen der Vorrichtung (102) nach einem der vorhergehenden Ansprüche, wobei das Verfahren die folgenden Schritte umfasst: Ansetzen des Trägers (4) der Vorrichtung (102) neben ausgewählten Haarsträhnen eines Haarschopfes und Anpressen von Haarsträhnen an das genannte Befestigungsmittel, um wenigstens ein Teil der ersten Mehrzahl von Teilen (6) neben wenigstens einer angepressten Haarsträhne anzuordnen und **dadurch** die genannte wenigstens eine Haarsträhne festzuhalten und den Träger in einer Position zu befestigen, in der die ausgewählten Haarsträhnen von anderen Haarsträhnen getrennt sind. 40
45
29. Verfahren nach Anspruch 28, ferner umfassend die Schritte des Faltens des Trägers (4) um die genannten ausgewählten Haarsträhnen und Anpressen wenigstens eines Teils der zweiten Mehrzahl von Teilen (104) an die genannte erste Mehrzahl von Teilen (6), sodass das wenigstens eine Teil der zweiten Mehrzahl von Teilen (104) und der ersten Mehrzahl von Teilen einander festhalten. 50
55

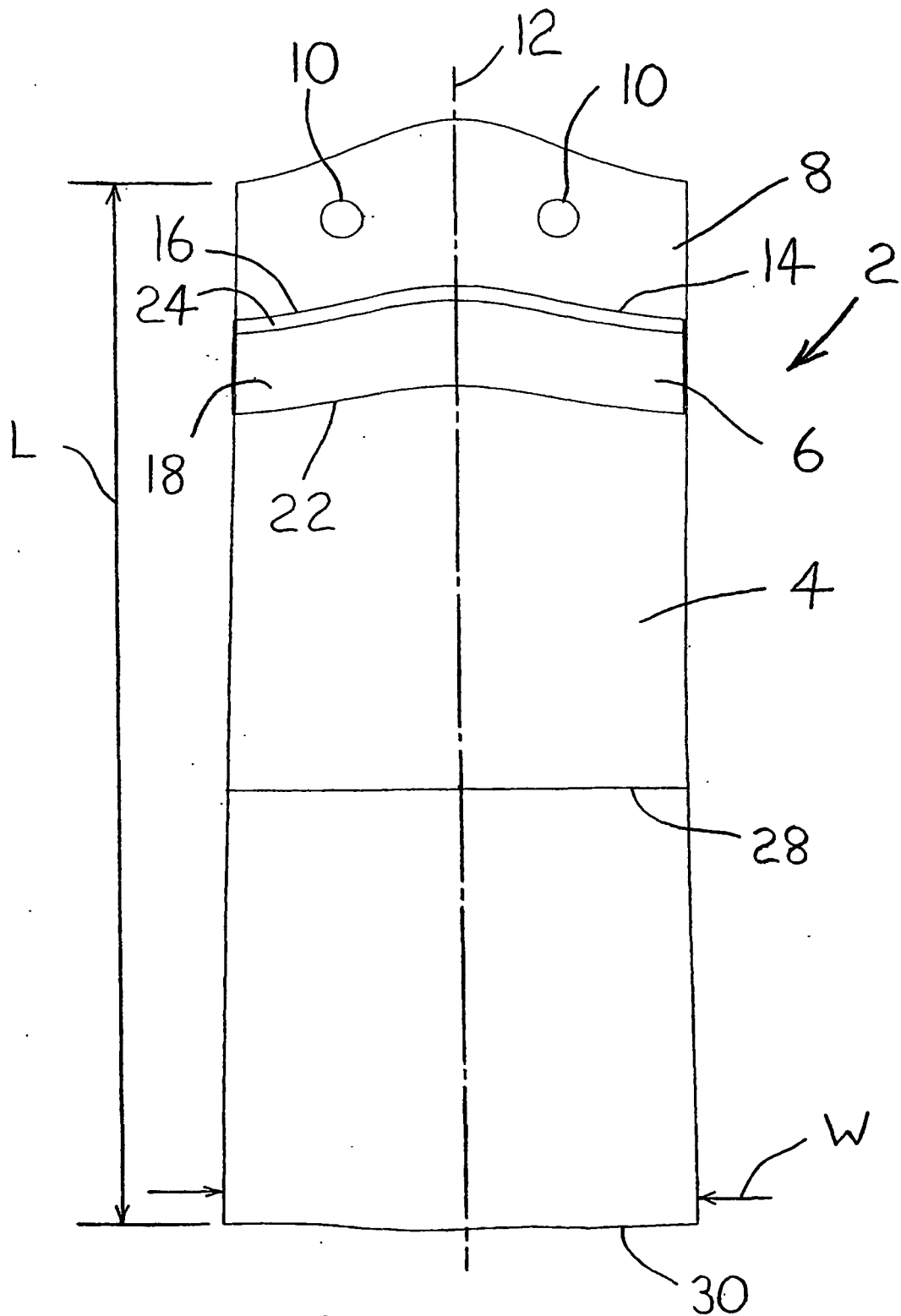

FIG. 1

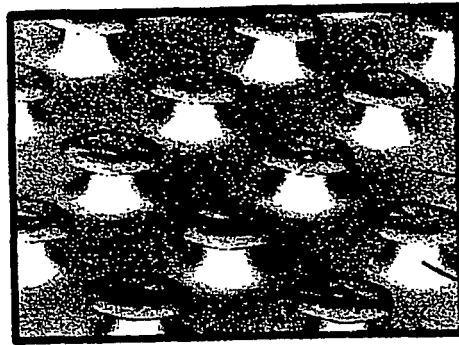

FIG. 2

18
20

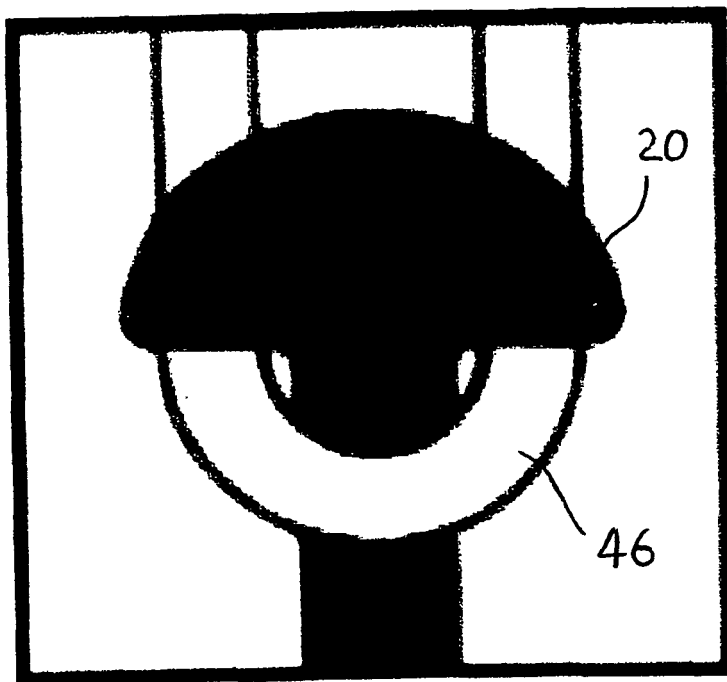

FIG. 3

20
46

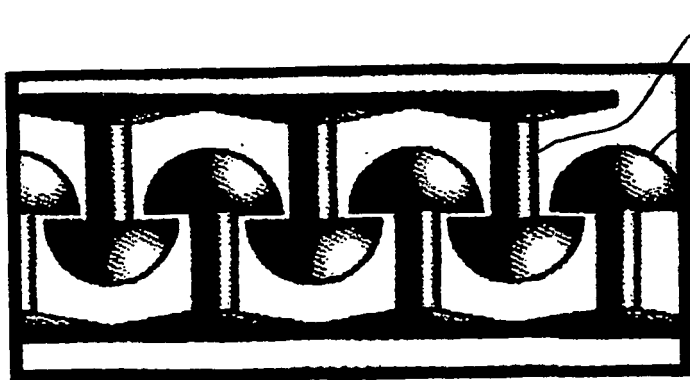
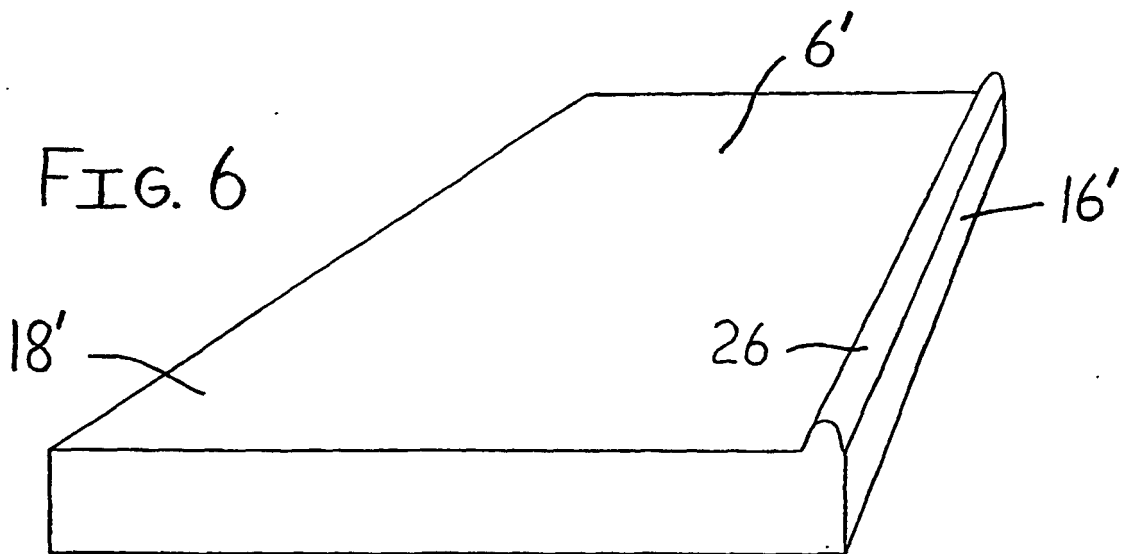
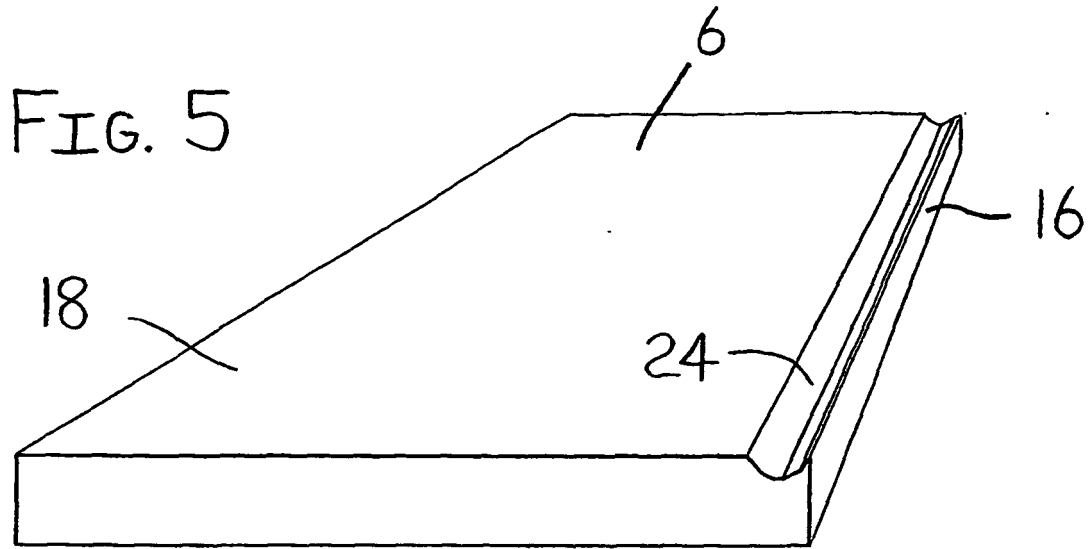

FIG. 4

48
20



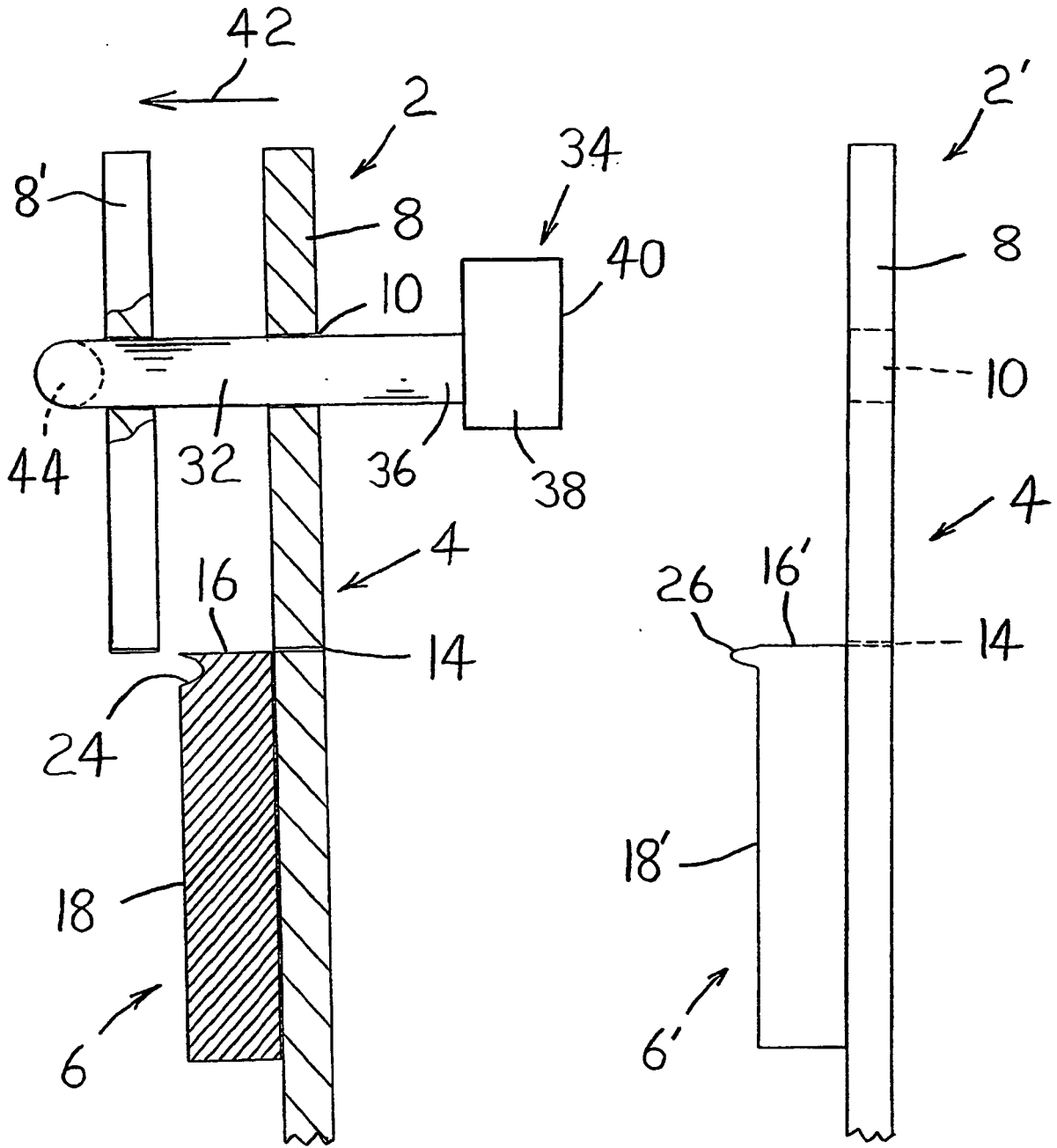

FIG. 7

FIG. 8

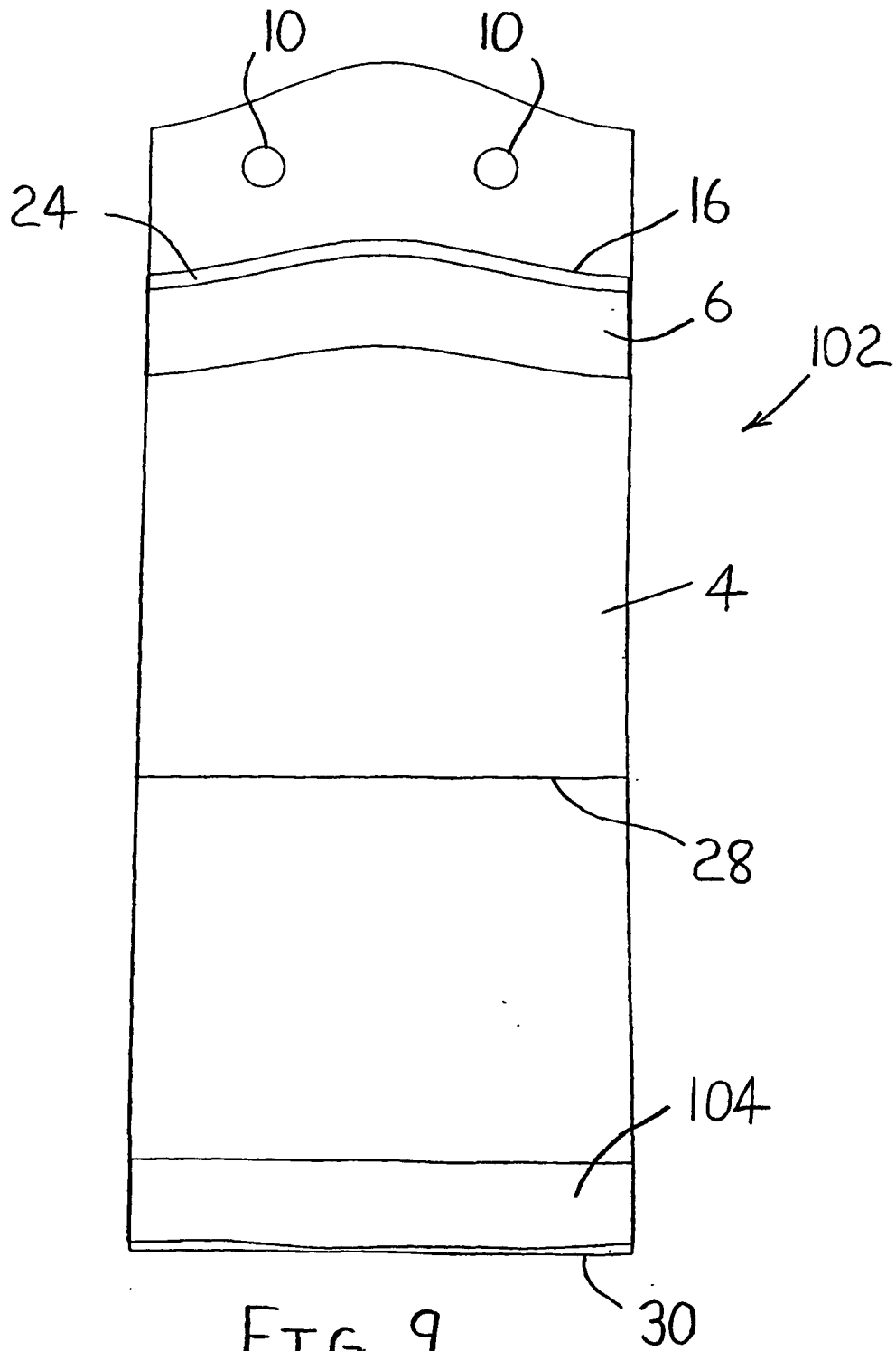

FIG. 9

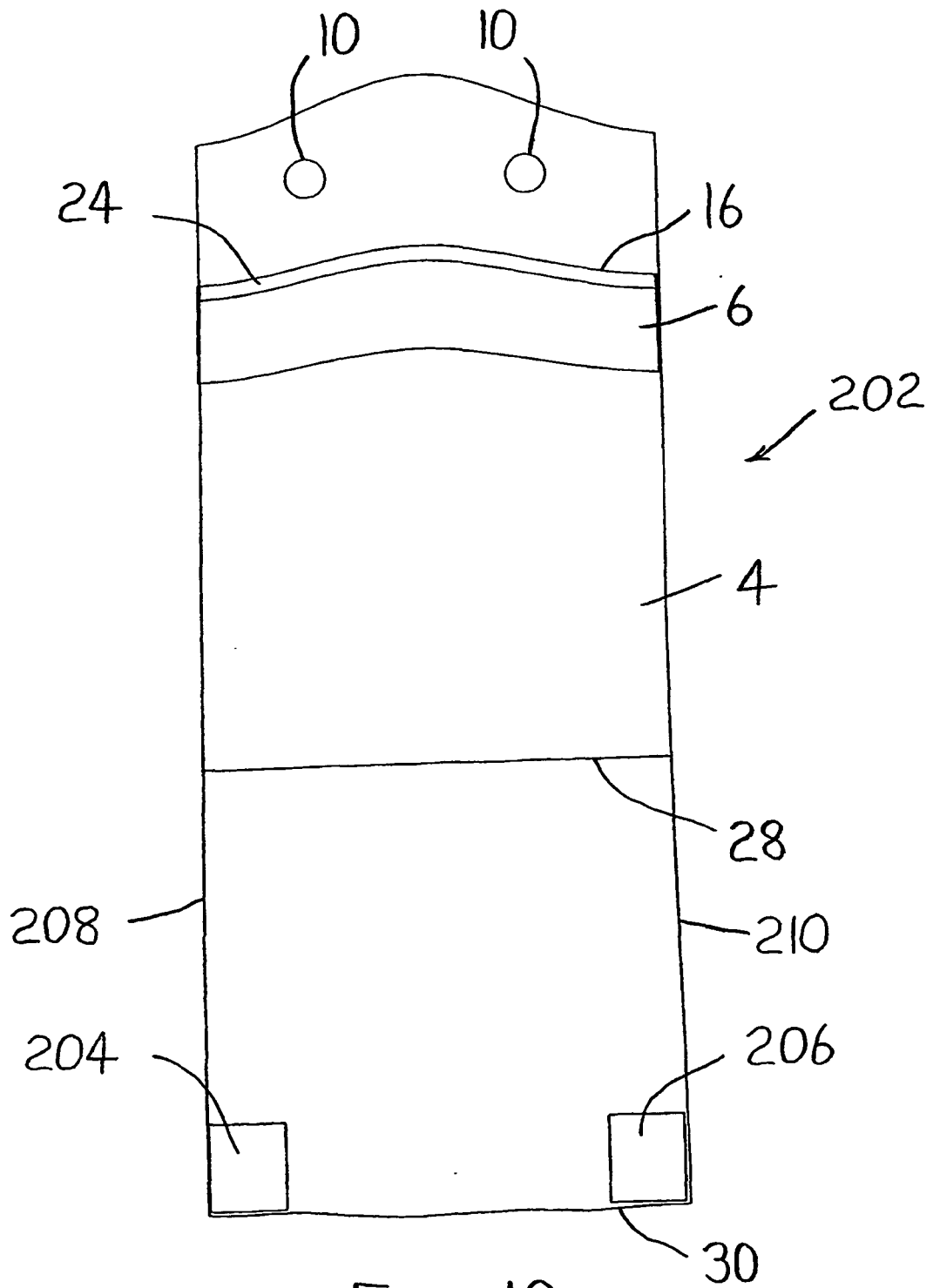

FIG. 10

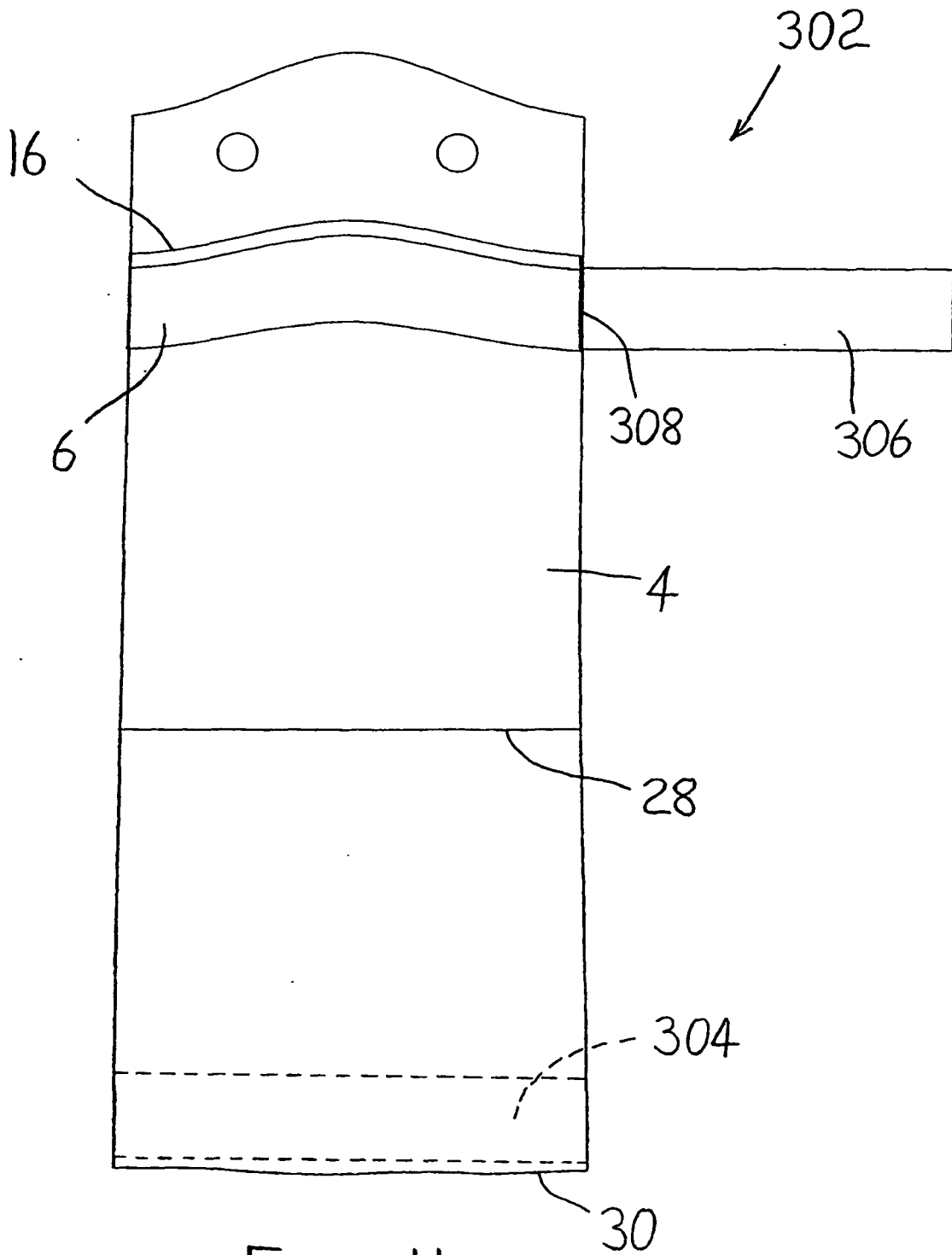

FIG. 11

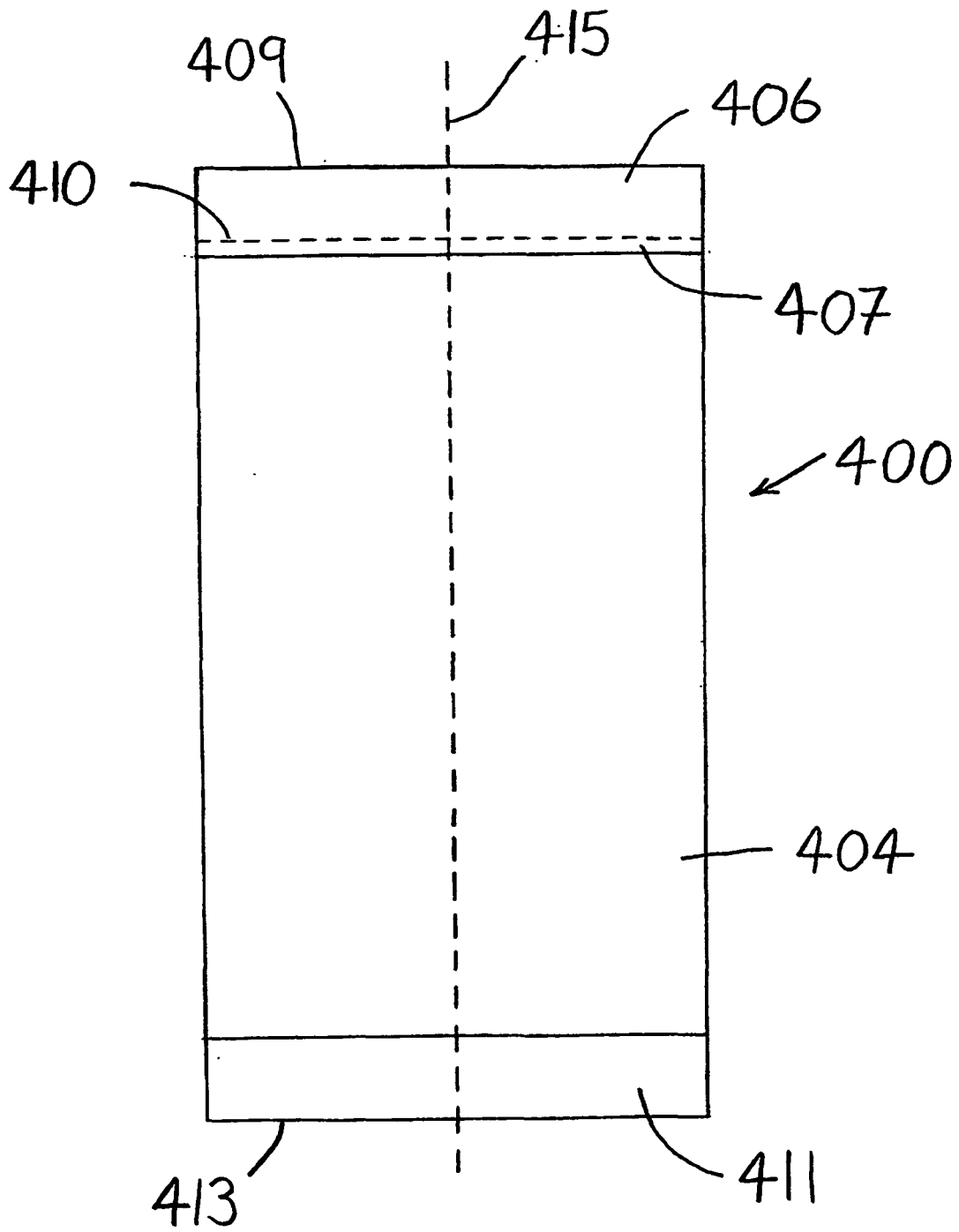

FIG. 12

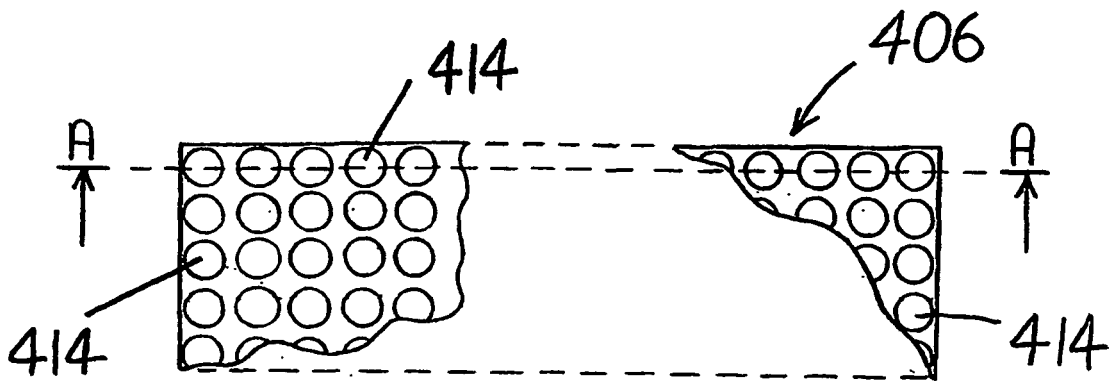

FIG. 13

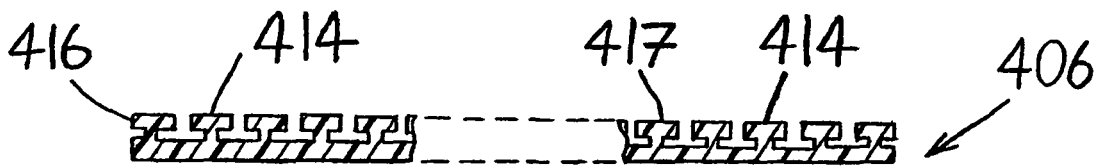

FIG. 14

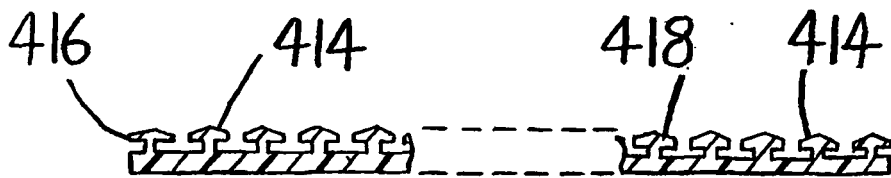

FIG. 15

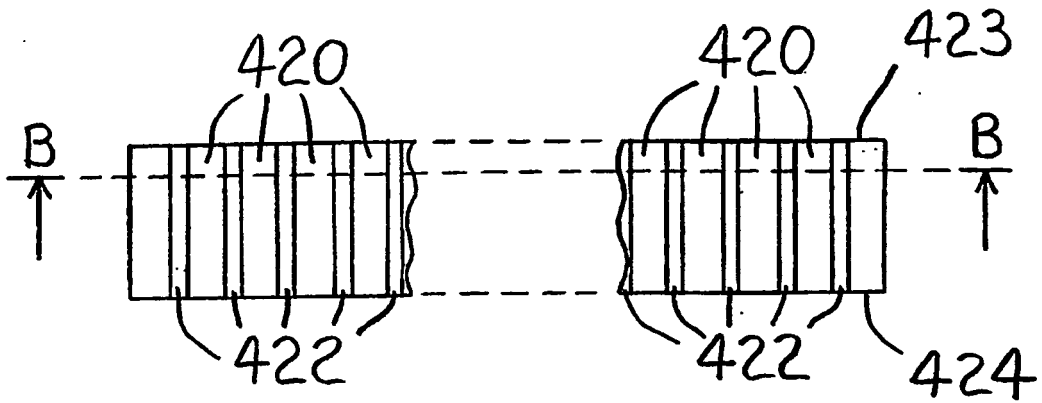

FIG. 16

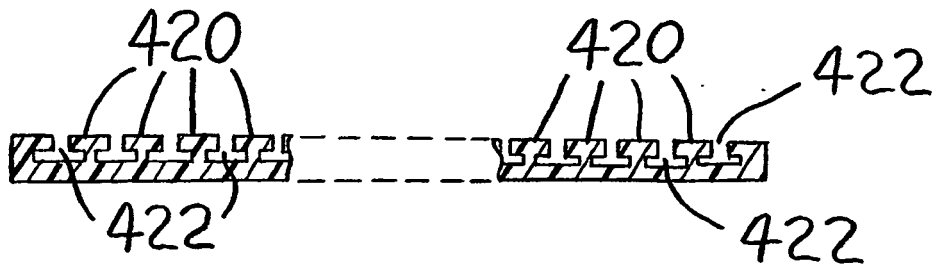

FIG. 17

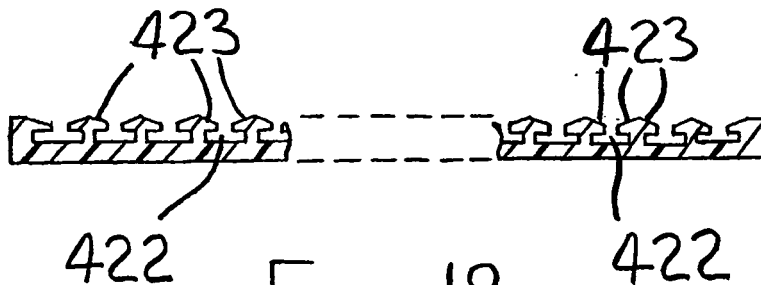

FIG. 18