

## **Bus Hand Pole**

### **Field of the Invention**

The invention relates to the field of passenger service vehicles. In particular, but not exclusively, the invention relates to hand poles installed in passenger vehicles to assist  
5 passengers when remaining standing as the vehicle moves and in walking about the interior of the vehicle.

### **Background to the Invention**

As used herein, the term "passenger service vehicle" encompasses vehicles for  
10 transporting passengers and, in particular, road vehicles for transporting passengers. Exemplary passenger service vehicles may be buses, coaches or the like.

Passenger service vehicles are often operated in fleets, with the vehicles being centrally serviced or maintained such as at a fleet depot.

15

Significant innovation and technology development has occurred in recent years in relation to the design of passenger service vehicles. In particular, there has been a continued drive towards providing vehicles that allow for, for example, improved passenger accommodation, vehicle handling, fuel efficiency, and ease of maintenance,  
20 etc.

20

In a typical passenger vehicle, when moving between sitting and standing positions, and when travelling in a standing position, hand poles are provided at frequent intervals in the vehicle interior. They provide readily grasped, secure, hand holds for  
25 passengers. The requirement for hand poles is often mandated by regulations in a given country.

25

Typically hand poles are generally vertically disposed and running from floor to ceiling or, often, from a seat back to ceiling within a vehicle. In modern passenger vehicle designs the hand poles may be curved, for example to provide more space and more comfortable gripping by a standing passenger, and may in some arrangements include  
30 one or more bends.

30

Fittings within the passenger compartment of a passenger vehicle, such as hand poles, are desirably robust, low maintenance, tamper resistant and do not present edges, projections or nips where passengers, their clothing or their belongings can be harmed or damaged.

5

### **Description of the Invention**

According to a first aspect the present invention provides a hand pole and socket arrangement for use in a passenger service vehicle, the arrangement comprising:

a hand pole having a first end; and

10

a first socket for fitting to a passenger vehicle and for receiving the first end of the hand pole;

wherein the first end of the hand pole and the first socket are formed and arranged to prevent rotation of the hand pole relative to the socket when they are fitted together.

15

The pole will typically be a metal tube that may be coated with a plastic surface layer. The plastic surface layer may be textured to improve passenger grip.

20

Prevention of rotation of a hand pole is an important consideration as passengers require secure fixed fittings that they can grasp to support themselves on a moving vehicle. A rotating pole does not provide a secure grasping place. The situation is more dangerous when the hand pole is curved or has bends in it. Rotation about the ends of the hand pole gives a lateral displacement of the grasping place as the pole rotates.

25

In addition hand poles are frequently fitted between a seat back and the ceiling of a passenger vehicle. In use the seat back flexes, changing the distance between the ceiling and the seatback. The hand pole and associated fittings, such as sockets, must be sufficiently compliant to cope with expected increase and decrease of the ceiling to seatback distance as the vehicle is used.

30

35

This can be achieved by providing a ceiling socket in which the ceiling end of the hand pole may move up and down i.e. the ceiling socket encircles the end of the hand pole sufficiently far along its length to retain the pole end under all normal working conditions. Even where fitted in other places, for example between a ceiling and a floor

of the passenger vehicle, some flexing of the distance between the two end points of a hand pole arrangement (e.g. the socket locations) may be experienced; requiring some compliance in the hand pole and associated fittings.

5 A prior art approach to prevent rotation has been to drill a hole through a socket and the end of a hand pole received within it. A fixing such as a rivet or a bolt is inserted to prevent rotation between the pole and the socket. However such a fixing has externally visible parts (rivet ends, bolts or nuts) which may catch on passengers, their clothing or belongings unless made smooth or covered by further fittings. Furthermore  
10 making a hole transversely through a generally cylindrical socket weakens it and may lead to cracking or breaking especially when pressure is applied to the pole by passengers, even more especially when the pole is curved or includes a bend or bends and the lever force applied by passenger activity is therefore greater.

15 The prevention of rotation between a first end of the hand pole and its corresponding first socket may be achieved in accordance with the invention by providing a radially outwardly extending projection on the hand pole end and a corresponding radially outwardly extending depression on the interior wall of the socket. The projection fits in the depression preventing relative rotation of the socket and pole end in use.  
20 Alternatively a radially inwards projection on the inside wall of the socket may fit into a radially inwards depression on the end of the hand pole, to prevent relative rotation. With either of these alternatives the parts that prevent rotation need not be externally visible as they are contained inside the socket body.

25 More than one projection and corresponding depression pair may be employed. For example two diametrically opposed projections and corresponding depressions.

The projection or projections employed may be resiliently biased towards the corresponding depression. For example by being spring loaded. This biasing  
30 maintains firm contact between the projection and depression, reducing or preventing rattling caused by engine vibration.

Advantageously the first socket and first end of the hand pole are formed and arranged to both prevent rotation of the hand pole relative to the socket and also to be  
35 sufficiently compliant to cope with expected increases and decreases of the distance

between end points such as socket locations on e.g. the ceiling and a seatback of a passenger vehicle.

5 This can be achieved by providing a radially outwardly extending projection on the hand pole first end and a corresponding radially outwardly extending depression on the interior wall of the first socket that is in the form of an axially extending groove. Axial motion of the pole relative to the socket can occur as the projection can move back and forth along the groove. As the distance between the points of attachment to the vehicle of the sockets (or other fixings) at either end of the hand pole changes the relative motion allowed by the projection and groove arrangement prevents damage. At the 10 same time the projection fits in the groove preventing relative rotation of the socket and pole end in use.

15 Alternatively a radially inwards projection on the inside wall of the socket may fit into a radially inwards depression, that is in the form of an axially extending groove, on the outer surface of the first end of the hand pole, to prevent rotation but to allow axial motion of the pole relative to the socket. With either of these alternatives the parts that prevent rotation need not be externally visible as they are contained inside the socket body.

20 With either of these two alternatives the first socket is conveniently fixed to the uppermost (e.g. the ceiling) end of the hand pole. The other, lower end of the hand pole may rest under gravity against the base of a socket or other fixing it connects to. The lower end of the hand pole may rest on a part of the seat back or the floor of the passenger vehicle, where the second socket (or other second fixing) does not have a 25 base. By providing the arrangement with the first socket and first end of the hand pole uppermost, typically fixing to the ceiling of a passenger vehicle, the relative axial motion of the first socket and first end of the hand pole is generally out of the passengers grasp region. This avoids the socket and pole junction being a nip which might catch a passengers clothing. 30

35 Conveniently the first socket may be attached to e.g. a ceiling, by means of fixings such as bolts through flanges extending laterally of the socket. The flanges may be concealed in a groove of a ceiling fitting that allows the socket to be attached at any point along the groove. The flanges may then be covered by a protective and or

decorative sheeting to present an appearance without externally visible fixing components.

5 In a particularly convenient arrangement the first end of the hand pole is provided with a spring loaded projection to fit in a corresponding axially extending groove on the inside surface of the first socket. The spring loaded projection, may take the form of a spring loaded pin such as are commercially available. The spring loaded pin may be inserted radially into the hand pole transverse to its longitudinal axis. Even more conveniently and as illustrated by example hereafter, the spring loaded pin may be  
10 inserted through a diameter of the hand pole to provide two diametrically opposed outwards projections that fit into corresponding axial grooves in the inside wall of the first socket. This arrangement provides firm contact between the projections and grooves, reducing or preventing rattling caused by engine vibration, even as the hand pole and first socket move up and down relative to each other.

15

In such an arrangement the spring loaded pin may be single or double ended i.e. be provided with one end that can move inwardly and outwardly with respect to the pin body or be provided with two ends each of which can move inwardly and outwardly with respect to the pin body.

20

In arrangements of the invention, the second end of the hand pole may have a second end of the same type as the first end, for fitting into a corresponding second socket. The second socket and second end are in this case formed and arranged to prevent rotation of the hand pole relative to the socket. They may also be formed and arranged  
25 to be compliant, to allow some axial movement of the second pole end in the second socket.

Alternatively, for example, the second end of the hand pole may simply be circular in cross section and may fit, in use, to a second socket that receives and holds it in place  
30 when fitted to a suitable location in a passenger vehicle. In such an example only the first socket and first end of the hand pole prevent rotation of the hand pole.

In a yet further example the second end of the hand pole may be clamped in a second socket and so not readily able to rotate. However whilst such an arrangement may be  
35 effective in preventing easy movement of the pole end (e.g. preventing rattling due to

vibration from the vehicle motor), it may not be effective in preventing rotation of the pole over a period of time, when under pressure from frequent passenger use. Therefore the effective prevention of rotation is provided by the first socket and first hand pole end and their interlocking engagement by projections/grooves.

5

Whilst the hand pole and socket arrangements described herein find use in passenger vehicles, it will be appreciated that they may be employed in any situation where prevention of rotation and/or compliance with a varying distance between the end points of a hand pole arrangement is/are desired.

10

The present invention also provides a passenger service vehicle comprising one or more hand pole and socket arrangements as discussed herein. The passenger service vehicle may typically be a road vehicle such as a bus or coach. However other road vehicles such as trams are also contemplated, as are other track vehicles such as trains. The invention may also be employed with water craft such as boats and ships, used as passenger service vehicles.

15

### **Brief Description of the Drawings**

Figures 1A and 1B show in plan and cross section elevation views one end of a hand pole and socket arrangement;

20

Figure 1C shows in cross section elevation the other end of the hand pole and socket arrangement of figures 1a, 1B;

Figure 2A shows in perspective cut away detail another hand pole and socket arrangement;

25

Figure 2B shows a perspective view of the hand pole and socket arrangement of figure 2A; and

Figure 2C another perspective view of the hand pole and socket arrangement of figure 2A.

30

### **Detailed Description of the Invention**

Figure 1A shows an end of a hand pole and socket arrangement 1 in schematic plan view with a corresponding schematic cross section elevation about Y-Y shown in figure 1B. In the arrangement of 1A, 1B the first end 2 of a cylindrical hand pole 3 is received in a first socket 4, which is generally conical in form with a cylindrical inner surface 5.

35

Flanges 6 are provided with bolt holes 8 for fixing to a floor of a passenger vehicle.

Alternative fixing arrangements for attaching first socket 4 to a seat back in the known manner could be provided if desired.

5 A projection 10 extending radially outwardly of the first end of the pole 2 fits inside a corresponding depression 12 in the inner wall of socket 4, preventing rotation of pole 3 relative to socket 4 as suggested by double headed arrow R. In this example projection 10 is provided by an end of a pin 14 inserted diametrically into first pole end 2 through hole 16.

10 The arrangement shown in figures 1A and 1B has the disadvantage that any significant vertical play required due to changing distance between socket 4 and a socket at the other end of hand pole 3 will not be accommodated at first pole end 2. However as shown in schematic cross section figure 1C, the second pole end 18 distal to the first pole end 2 may be fitted in a second socket 20 for attaching via bolt holes 8 to a ceiling of a passenger vehicle (suggested by dashed line 22). Second socket 20 has generally the same form as that of first socket 4 but without depression 12. Second pole end 18 does not feature a radial projection. The second pole end 18 fits inside second socket 20 but is free to move vertically as suggested by double headed arrow X with the second pole end 18 moving in captive sliding engagement relative to second socket 20. The extreme end 24 of pole end 18 is spaced below the ceiling level 22 so as to allow some upwards movement in use.

25 Figure 2A shows in a detail perspective cut away view an end of a hand pole and socket arrangement 1 fitted into a ceiling fitment 26 of the ceiling of a passenger vehicle. The pole end and socket arrangement 1 includes the first pole end 2 of a curved hand pole 3 (see wider view 2B) located in a first socket 4 which is shown cut away to allow viewing of the pole end 2 in the interior. The socket 4 has a generally cylindrical inner surface wall 5, which includes two axially extending grooves 28, 30. The grooves 28, 30 each receive a projection 10 in the form of either end 32, 34 of a spring loaded pin 14 passing diametrically through pole end 2.

30 In this example both ends 32, 34 of the pin 14 are spring loaded so that each is independently resiliently biased towards its corresponding groove 28, 30. In use the pin ends 32, 34 prevent relative rotation of the pole 3 and the socket 4 whilst at the

same time allowing relative axial motion as the pin ends 32, 34 can move up and down in the grooves 28, 30.

5 The other end of pole 3 will typically be connected by fitting into a suitable socket or clamp arrangement on the floor or on a seat back of the passenger vehicle.

10 The socket 4 is shown fitting into a channel (groove) 36 of ceiling fitment 26, with a cover sheeting 38 providing a cover finish to the channel 36 where hand poles or other fittings to the ceiling are not required. A transverse groove on the exterior of the socket 4 includes a lip 40 into which the cover sheeting 38 fits to complete a tidy appearance.

15 The socket is attached to the ceiling fitment by means of flanges 6 (such as found on the sockets 4 of figure 1A), bolted into channel 36 by making use of captive nuts 40 held in a sub channel 42 of channel 36 (see figure 2B).

20 Figure 2C shows another perspective view of arrangement 1 as shown in figures 2a, 2B, but without cut away at the pole to allow viewing of interior parts. This illustrates the tidy design possible with the arrangements of the invention, without exterior fixing components.

The arrangement of figures 2 provides a robust, non-rotating yet axially extendible hand pole and socket for fitting to a ceiling or other suitable location in a passenger vehicle.



**CLAIMS:**

1. A hand pole and socket arrangement for use in a passenger service vehicle, the arrangement comprising:
- 5 a hand pole having a first end; and  
a first socket for fitting to a passenger vehicle and for receiving the first end of the hand pole;
- wherein the first end of the hand pole and the first socket are formed and arranged to prevent rotation of the hand pole relative to the socket when they are fitted
- 10 together, and further:
- wherein the prevention of rotation is achieved by either:
- providing a radially outwardly extending projection on the first end of the hand pole and a corresponding radially outwardly extending depression on the interior wall of the first socket; or
- 15 providing a radially inwards extending projection on the inside wall of the first socket and a corresponding radially inwards extending depression on the first end of the hand pole;
- wherein the projection or projections is/are resiliently biased towards the corresponding depression or depressions; and
- 20 wherein, in either alternative, the projection fits in the depression preventing relative rotation of the first socket and first pole end in use.
2. The hand pole and socket arrangement according to claim 1, wherein two diametrically opposed projections and corresponding two depressions are provided on
- 25 the first socket and first pole end.
3. The hand pole and socket arrangement according to claim 1 or claim 2, wherein the projection or projections are spring loaded.
- 30 4. The hand pole and socket arrangement according to any preceding claim wherein either:
- the corresponding radially outwardly extending depression or depressions on the interior wall of the first socket; or
- the corresponding radially inwards extending depression or depressions on the
- 35 first end of the hand pole;

is/are in the form of an axially extending groove.

5. The hand pole and socket arrangement according to claim 4, when the corresponding radially outwardly extending depression or depressions are provided on the interior wall of the first socket and wherein the projection or projections take the form of a spring loaded pin or pins inserted radially into the first end of the hand pole transverse to its longitudinal axis.
6. The hand pole and socket arrangement according to claim 5, wherein a spring loaded pin is inserted through a diameter of the first end of the hand pole to provide two diametrically opposed outwards projections that fit into corresponding axial grooves on the inside wall of the first socket.
7. The hand pole and socket arrangement according to claim 6, wherein the spring loaded pin is double ended.
8. The hand pole and socket arrangement according to any preceding claim wherein the hand pole is generally vertically disposed in use and the first socket and first end of the hand pole are uppermost in use.
9. The hand pole and socket arrangement according to any preceding claim wherein the second end of the hand pole is circular in cross section and the arrangement further comprises a second socket, wherein the second end of the hand pole fits in use to the second socket that receives and holds the second end when fitted in a suitable location in a passenger vehicle.
10. The hand pole and socket arrangement according to any one of claims 1 to 8 wherein the second end of the hand pole has the same features as claimed for the first end and a corresponding second socket is provided that has the same features as claimed for the first socket.
11. The hand pole and socket arrangement according to any one of claims 1 to 8 wherein the arrangement further comprises a second socket, wherein the second end of the hand pole is clamped in use into the second socket when fitted in a suitable location in a passenger vehicle.

12. The hand pole and socket arrangement according to any preceding claim wherein the first socket includes flanges extending laterally of the socket for attachment to a surface.

5

13. The hand pole and socket arrangement according to claim 12, further including a groove in a ceiling fitting formed to allow attachment of the socket at any point along the groove.

10

14. The hand pole and socket arrangement according to claim 13, further comprising a protective and/or decorative sheeting that covers the flanges extending laterally of the socket.

15

15. A passenger service vehicle comprising a hand pole and socket arrangement according to any one of claims 1 to 14.

20

16. The passenger service vehicle of claim 15, wherein the passenger service vehicle is selected from the group consisting of buses, coaches, trams, trains, boats and ships.

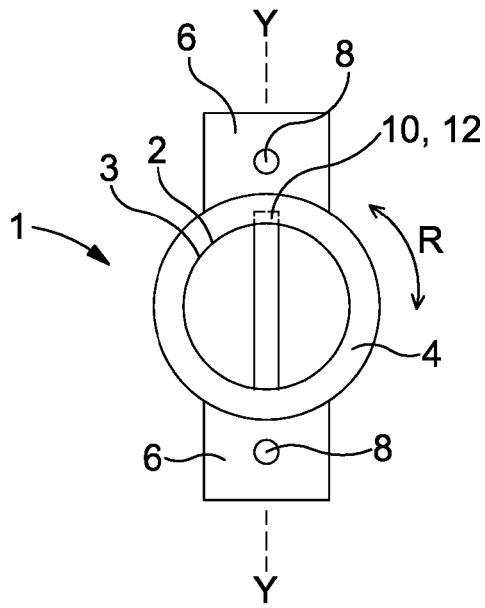

Fig. 1a

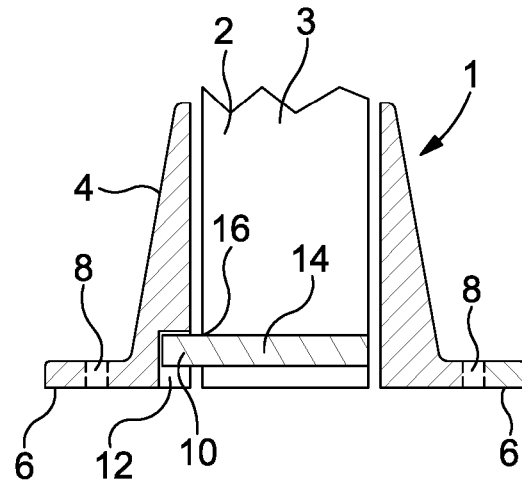

Fig. 1b

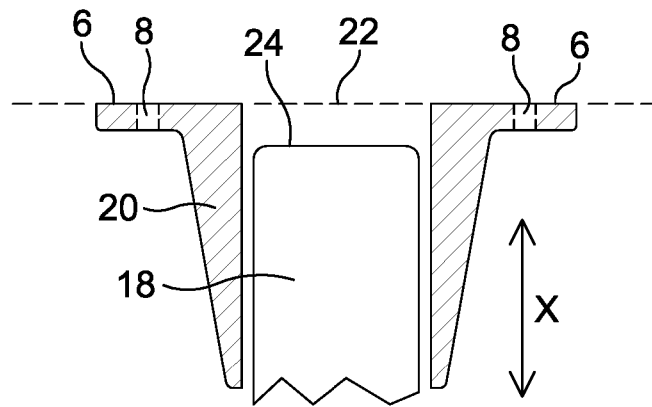

Fig. 1c

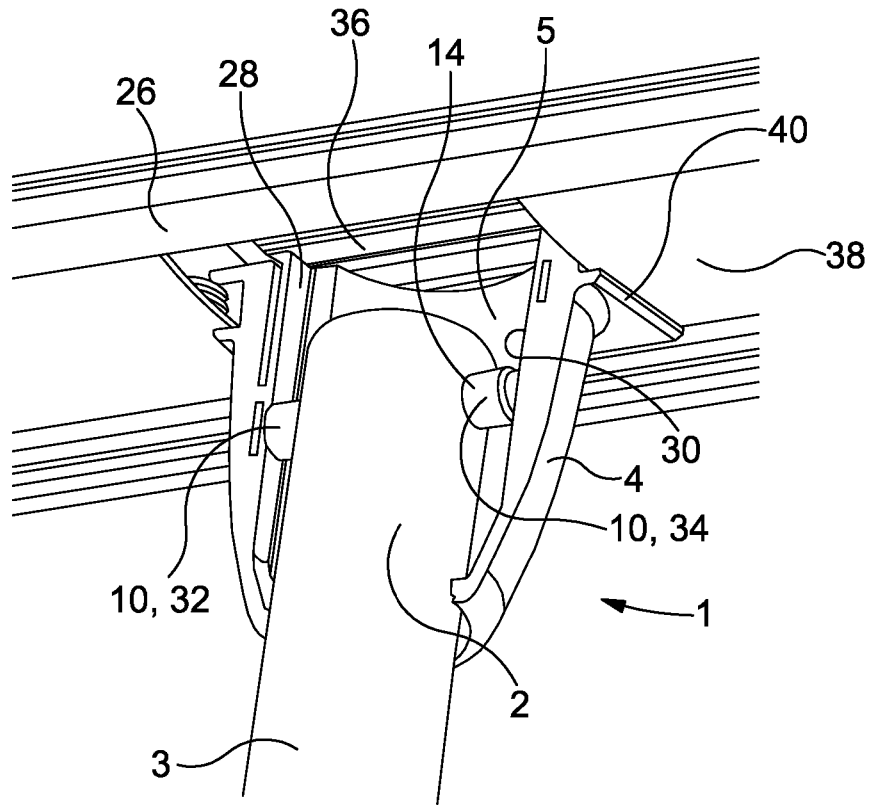

Fig. 2a

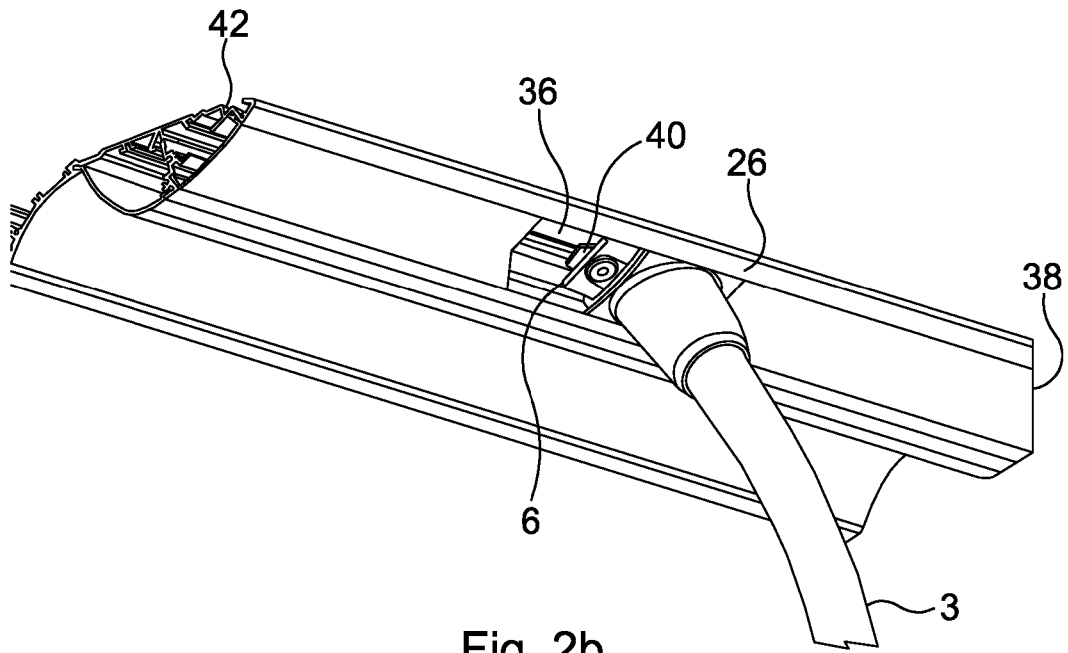

Fig. 2b

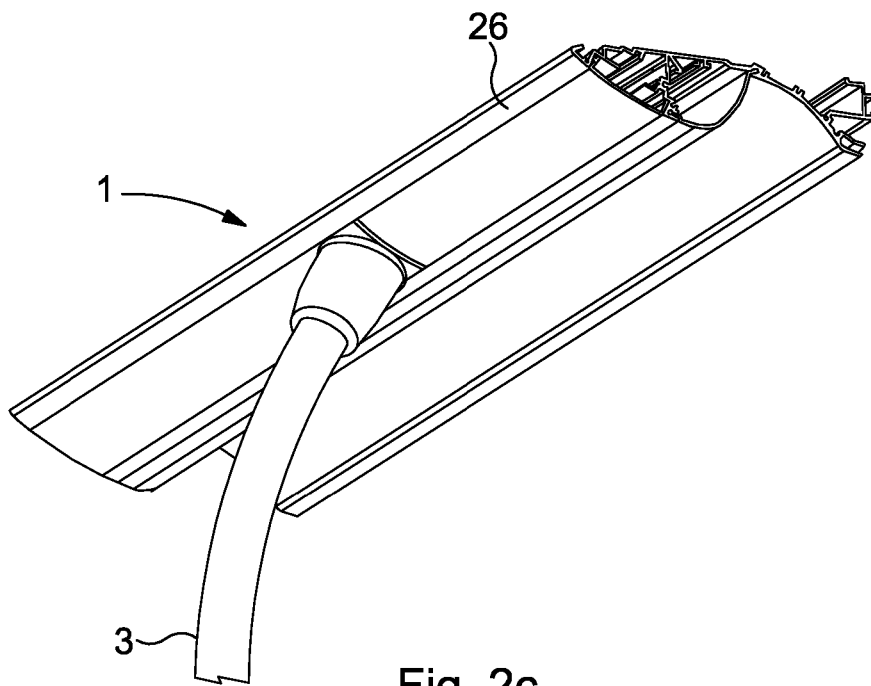

Fig. 2c