



- (51) International Patent Classification: *B01L 3/00* (2006.01) *B01L 3/14* (2006.01)
- (21) International Application Number: PCT/US2015/020797
- (22) International Filing Date: 16 March 2015 (16.03.2015)
- (25) Filing Language: English
- (26) Publication Language: English
- (30) Priority Data:
62/079,216 13 November 2014 (13.11.2014) US
14/629,643 24 February 2015 (24.02.2015) US
- (71) Applicant: **BECTON, DICKINSON AND COMPANY** [US/US]; 1 Becton Drive, Franklin Lakes, NJ 07417 (US).
- (72) Inventors: **LOSADA, Robert, J.**; 22-63 23rd Street, Astoria, NY 11105 (US). **NAIR, Arun, U.**; 501 Chandler Lane, Whippany, NJ 07981 (US).
- (74) Agents: **QUEEN, Lara, Northrop** et al.; The Webb Law Firm, One Gateway Center, 420 Ft. Duquesne Blvd., Suite 1200, Pittsburgh, PA 15222 (US).
- (81) Designated States (unless otherwise indicated, for every kind of national protection available): AE, AG, AL, AM, AO, AT, AU, AZ, BA, BB, BG, BH, BN, BR, BW, BY, BZ, CA, CH, CL, CN, CO, CR, CU, CZ, DE, DK, DM, DO, DZ, EC, EE, EG, ES, FI, GB, GD, GE, GH, GM, GT, HN, HR, HU, ID, IL, IN, IR, IS, JP, KE, KG, KN, KP, KR, KZ, LA, LC, LK, LR, LS, LU, LY, MA, MD, ME, MG, MK, MN, MW, MX, MY, MZ, NA, NG, NI, NO, NZ, OM, PA, PE, PG, PH, PL, PT, QA, RO, RS, RU, RW, SA, SC, SD, SE, SG, SK, SL, SM, ST, SV, SY, TH, TJ, TM, TN, TR, TT, TZ, UA, UG, US, UZ, VC, VN, ZA, ZM, ZW.
- (84) Designated States (unless otherwise indicated, for every kind of regional protection available): ARIPO (BW, GH, GM, KE, LR, LS, MW, MZ, NA, RW, SD, SL, ST, SZ, TZ, UG, ZM, ZW), Eurasian (AM, AZ, BY, KG, KZ, RU, TJ, TM), European (AL, AT, BE, BG, CH, CY, CZ, DE, DK, EE, ES, FI, FR, GB, GR, HR, HU, IE, IS, IT, LT, LU, LV, MC, MK, MT, NL, NO, PL, PT, RO, RS, SE, SI, SK,

[Continued on next page]

(54) Title: MECHANICAL SEPARATOR FOR A BIOLOGICAL FLUID

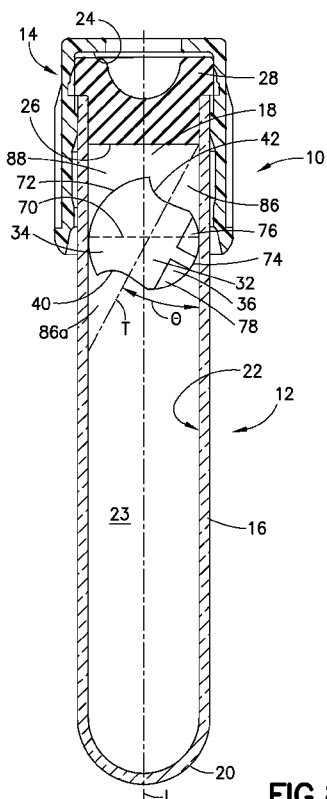

FIG. 8

(57) Abstract: A separation assembly for separation of a fluid into first and second parts is disclosed. A container has a sidewall defining an interior, the container defining a longitudinal axis between the first end and the second end. A separator body is disposed within the interior having a through-hole defined therethrough. The separator body includes a first part, and a second part interfaced with the first part, wherein the separator body is transitionable from a first position wherein the through-hole is provided in fluid-receiving alignment with the first end of the container, to a second position wherein the through-hole is provided substantially perpendicular to the longitudinal axis of the container. In the first position, a through-axis of the through-hole of the separator body is in a plane that is not parallel with a plane containing the longitudinal axis of the container.

WO 2016/076911 A1

SM, TR), OAPI (BF, BJ, CF, CG, CI, CM, GA, GN, GQ, GW, KM, ML, MR, NE, SN, TD, TG). **Published:**

— with international search report (Art. 21(3))

MECHANICAL SEPARATOR FOR A BIOLOGICAL FLUID

CROSS-REFERENCE TO RELATED APPLICATION

[0001] The present application claims priority to United States Provisional Patent Application No. 62/079,216, entitled "Mechanical Separator for a Biological Fluid" filed November 13, 2014, the entire disclosure of which is hereby incorporated by reference.

BACKGROUND OF THE INVENTION

Field of the Invention

[0002] The subject invention relates to a device for separating higher and lower density fractions of a fluid sample. More particularly, this invention relates to a device for collecting and transporting fluid samples whereby the device and fluid sample are subjected to centrifugation in order to cause separation of the higher density fraction from the lower density fraction of the fluid sample.

Description of Related Art

[0003] Diagnostic tests may require separation of a patient's whole blood sample into components, such as serum or plasma (the lower density phase components), and red blood cells (the higher density phase components). Samples of whole blood are typically collected by venipuncture through a cannula or needle attached to a syringe or an evacuated blood collection tube. After collection, separation of the blood into serum or plasma and red blood cells is accomplished by rotation of the syringe or tube in a centrifuge. In order to maintain the separation, a barrier must be positioned between the higher density and lower density phase components. This allows the separated components to be subsequently examined.

[0004] A variety of separation barriers have been used in collection devices to divide the area between the higher density and lower density phases of a fluid sample. The most widely used devices include thixotropic gel materials, such as polyester gels. However, current polyester gel serum separation tubes require special manufacturing equipment to both prepare the gel and fill the tubes. Moreover, the shelf-life of the gel-based separator product is limited. Over time, globules may be released from the gel mass and enter one or both of the separated phase components. Furthermore, commercially available gel barriers may react chemically with the analytes. Accordingly, if certain drugs are present in the blood sample when it is taken, an adverse chemical reaction with the gel interface can occur. Furthermore, if an instrument probe is inserted too deeply into a collection container, then the instrument probe may become clogged if it contacts the gel.

[0005] Certain mechanical separators have also been proposed in which a mechanical barrier can be employed between the higher and lower density phases of the fluid sample. Conventional mechanical barriers are positioned between higher and lower density phase components utilizing elevated gravitational forces applied during centrifugation. For proper orientation with respect to plasma and serum specimens, conventional mechanical separators are typically positioned above the collected whole blood specimen prior to centrifugation. This typically requires that the mechanical separator be affixed to the underside of the tube closure in such a manner that blood fill occurs through or around the device when engaged with a blood collection set or phlebotomy needle. This attachment is required to prevent the premature movement of the separator during shipment, handling, and blood draw. Conventional mechanical separators are typically affixed to the tube closure by a mechanical interlock between the bellows component and the closure.

[0006] Conventional mechanical separators have some significant drawbacks. As shown in FIG. 1, conventional separators include a bellows 2 for providing a seal with a tube or syringe wall 4. Typically, at least a portion of the bellows 2 is housed within, or in contact with, a closure 6. As shown in FIG. 1, as a needle 8 enters through the closure 6, the bellows 2 is depressed. This creates a void 9 in which blood may pool during insertion or removal of the needle. This can result in sample pooling under the closure, device pre-launch in which the mechanical separator prematurely releases during blood collection, trapping of a significant quantity of fluid phases, such as serum and plasma, poor sample quality, and/or barrier failure under certain circumstances. Furthermore, previous mechanical separators are costly and complicated to manufacture due to the complicated multi-part fabrication techniques.

[0007] In addition, it is desired to reduce damage to the cellular structure of the fluid which can occur when the fluid or a portion of the fluid is trapped between the separator and the collection tube resulting in a shearing force being placed on the fluid.

[0008] Accordingly, a need exists for a separator device that is compatible with standard sampling equipment and reduces or eliminates the aforementioned problems of conventional separators. A need also exists for a separator device that is easily used to separate a blood sample, minimizes cross-contamination of the higher and lower density phases of the sample during centrifugation, is independent of temperature during storage and shipping, and is stable to radiation sterilization. A need further exists for a unitary separation device that requires fewer relative moving parts and that allows for enhanced ease of introducing a specimen into a collection container.

SUMMARY OF THE INVENTION

[0009] In accordance with an aspect of the present invention, a separation assembly for enabling separation of a fluid into first and second parts includes a container having a first end, a second end, and a sidewall extending therebetween having an inner surface and defining a container interior. The container defines a longitudinal axis between the first end and the second end. The separation assembly also includes a separator body disposed within the container interior and having a through-hole defined therethrough. The separator body includes a first part, and a second part interfaced with the first part. The separator body is transitionable from a first position in which the through-hole is provided in fluid-receiving alignment with the first end of the container, to a second position in which the through-hole is provided substantially perpendicular to the longitudinal axis of the container. In the first position, a through-axis of the through-hole of the separator body is in a plane that is not parallel with a plane containing the longitudinal axis of the container.

[0010] In certain configurations, the first part of the separator body is a float and the float defines an upper surface of the separator body and the second part of the separator body is a ballast and the ballast defines a lower surface of the separator body.

[0011] When the separator body is in the first position, the separator body may contact the sidewall of the container at a location that is offset from a center of the upper surface of the float. When the separator body is in the first position, the separator body may contact the sidewall of the container at a location that is offset from a center of the lower surface of the ballast. When in the second position, the separator body may contact the sidewall of the container at at least part of a periphery of the upper surface of the float, such as during centrifugation. When in the second position, the separator body may contact the sidewall of the container at the entire periphery of the upper surface of the float, such as after cessation of centrifugation.

[0012] In certain configurations, the first part of the separator body or a part of the first part of the separator body and a part of the second part of the separator body may define the through-hole.

[0013] In accordance with an aspect of the present invention, a separation assembly for enabling separation of a fluid into first and second parts includes a container having a first end, a second end, and a sidewall extending therebetween having an inner surface and defining a container interior. The container defines a longitudinal axis between the first end and the second end. The assembly also includes a separator body disposed within the

container interior and having a through-hole defined therethrough. The separator body includes a first part, and a second part interfaced with the first part. The separator body is transitionable from a first position in which the through-hole is provided in fluid-receiving alignment with the first end of the container, to a second position in which the through-hole is provided substantially perpendicular to the longitudinal axis of the container. In the first position, a through-axis of the through-hole is angled with respect to at least one of the longitudinal axis of the container and the sidewall of the container.

[0014] In certain configurations, in the first position, the through-axis of the through-hole is angled from about 30° to about 60° with respect to the sidewall of the container. The first part of the separator body may be a float and the float may define an upper surface of the separator body, and the second part of the separator body may be a ballast and the ballast may define a lower surface of the separator body.

[0015] In certain configurations, when in the first position, the separator body may contact the sidewall of the container at a location that is offset from a center of the upper surface of the float. When in the first position, the separator body may contact the sidewall of the container at a location that is offset from a center of the lower surface of the ballast.

[0016] In still other configurations, a first part of the separator body, or a part of the first part of the separator body and a part of the second part of the separator body may define the through-hole. When in the second position, the separator body may contact the sidewall of the container at at least part of a periphery of the upper surface of the float, such as during centrifugation. When in the second position, the separator body may contact the sidewall of the container at the entire periphery of the upper surface of the float, such as after cessation of centrifugation.

[0017] In accordance with another aspect of the present invention, a separation assembly for enabling separation of a fluid into first and second parts includes a container having a first end, a second end, and a sidewall extending therebetween having an inner surface and defining a container interior. The container defines a longitudinal axis between the first end and the second end. The assembly also includes a separator body disposed within the container interior and having a through-hole for fluid to pass therethrough. The separator body includes a first part, and a second part interfaced with the first part. The separator body is transitionable from a first position in which the through-hole is provided in fluid-receiving alignment with the first end of the container, to a second position in which the through-hole is provided substantially perpendicular to the longitudinal axis of the container. In the first

position, a through-axis of the through-hole of the separator is offset from the longitudinal axis of the container.

[0018] In certain configurations, the first part of the separator body is a float and the float defines an upper surface of the separator body, and the second part of the separator body is a ballast and the ballast defines a lower surface of the separator body. When in the first position, the separator body may contact the sidewall of the container at a location that is offset from a center of the upper surface of the float. When in the first position, the separator body may contact the sidewall of the container at a location that is offset from a center of the lower surface of the ballast.

[0019] In other configurations, the first part of the separator body or a part of the first part of the separator body and a part of the second part of the separator body may define the through-hole. When in the second position, the separator body may contact the sidewall of the container at at least part of a periphery of the upper surface of the float, such as during centrifugation. When in the second position, the separator body may contact the sidewall of the container at the entire periphery of the upper surface of the float, such as after cessation of centrifugation.

[0020] In accordance with another aspect of the present invention, a separation assembly for enabling separation of a fluid into first and second parts includes a container having a first end, a second end, and a sidewall extending therebetween having an inner surface and defining a container interior. The container defines a longitudinal axis between the first end and the second end. The separator body may be disposed within the container interior and may have a through-hole defined therethrough. The separator body includes a float and a ballast, with the float and the ballast being connected, and the float and the ballast both having leading parts, each defined by the float and the ballast end adjacent a second opening of the separator through-hole, and the float and ballast each having trailing parts, each defined by the float and ballast end adjacent the first opening of the separator through-hole. The separator body is transitionable from a first position in which the through-hole is provided in fluid-receiving alignment with the first end of the container, to a second position in which the through-hole is provided substantially perpendicular to the longitudinal axis of the container. In the first position, the trailing float part and the leading ballast part of the separator are provided adjacent the sidewall of the container and the leading float part and the trailing ballast part are spaced apart from the sidewall of the container.

BRIEF DESCRIPTION OF THE DRAWINGS

[0021] FIG. 1 is a partial cross-sectional side view of a conventional mechanical separator.

[0022] FIG. 2 is a cross-sectional view of a container in accordance with an embodiment of the present invention.

[0023] FIG. 3 is a perspective view of a mechanical separator in accordance with an embodiment of the present invention.

[0024] FIG. 4 is a top view of the mechanical separator of FIG. 3.

[0025] FIG. 5 is a front view of the mechanical separator of FIG. 3.

[0026] FIG. 6 is a cross-sectional view of the mechanical separator of FIG. 3 taken along the longitudinal axis X-X of the mechanical separator as shown in FIG. 5.

[0027] FIG. 7 is a side view of the mechanical separator of FIG. 3.

[0028] FIG. 8 is a partial cross-sectional front view of a separation assembly wherein the mechanical separator disposed within the container is in the first position for allowing fluid to pass through the through-hole in accordance with an embodiment of the present invention.

[0029] FIG. 9 is a partial cross-sectional front view of a separation assembly wherein the mechanical separator disposed within the container is in an intermediate position for allowing fluid to pass around the mechanical separator in accordance with an embodiment of the present invention.

[0030] FIG. 10 is a partial cross-sectional front view of a separation assembly wherein the mechanical separator is disposed within the container in a second position in accordance with an embodiment of the present invention.

DETAILED DESCRIPTION OF THE EMBODIMENTS

[0031] For purposes of the description hereinafter, the words “upper”, “lower”, “right”, “left”, “vertical”, “horizontal”, “top”, “bottom”, “lateral”, “longitudinal”, and like spatial terms, if used, shall relate to the described embodiments as oriented in the drawing figures. However, it is to be understood that many alternative variations and embodiments may be assumed except where expressly specified to the contrary. It is also to be understood that the specific devices and embodiments illustrated in the accompanying drawings and described herein are simply exemplary embodiments of the invention.

[0032] The separation assembly of the present invention is intended to provide separation of a sample into higher and lower density phase components, as will be discussed herein. For example, the present separation assembly can be used to provide a separation of serum or

plasma from whole blood through the use of differential buoyancy to cause a sealing area to contract when submerged in a specimen exposed to elevated gravitational forces through applied rotational force or centrifugation. In one embodiment, the elevated gravitational forces can be provided at a rate of at least 2,000 revolutions/minute, such as at least 3,400 revolutions/minute.

[0033] As shown in FIG. 2 and 8-10, a separation assembly 10 includes a container 12 having a closure 14. Specifically, the container 12 may be a sample collection tube, such as a proteomics, molecular diagnostics, chemistry sample tube, blood, or other bodily fluid collection tube, coagulation sample tube, hematology sample tube, and the like. Desirably, container 12 is an evacuated blood collection tube. The container 12 includes a first end 18, a second end 20, and a cylindrical sidewall 16 extending therebetween. The first end 18 may be an open top end and the second end 20 may be a closed bottom end. The cylindrical sidewall 16 includes an inner surface 22 and defines a container interior 23. The container 12 also defines a longitudinal axis L between the first end 18 and the second end 20 with an inside diameter extending substantially uniformly from the first end 18 to a location substantially adjacent the second end 20 along the longitudinal axis L of the container 12.

[0034] In one embodiment, the container 12 may contain additional additives as required for particular testing procedures, such as protease inhibitors, clotting agents, and the like. Such additives may be in particle or liquid form and may be sprayed onto the cylindrical sidewall 16 of the container 12 or located at the closed bottom second end 20 of the container 12.

[0035] The container 12 may be made of one or more than one of the following representative materials: polypropylene, polyethylene terephthalate (PET), glass, or combinations thereof. The container 12 can include a single wall or multiple wall configurations. Additionally, the container 12 may be constructed in any practical size for obtaining an appropriate biological sample. For example, the container 12 may be of a size similar to conventional large volume tubes, small volume tubes, or microliter volume tubes, as is known in the art. In one particular embodiment, the container 12 may be a standard 13 ml evacuated blood collection tube, as is also known in the art.

[0036] The open top first end 18 is structured to at least partially receive the closure 14 therein to form a liquid impermeable seal. The closure 14 includes a top end 24 and a bottom end 26 structured to be at least partially received within the container 12. Portions of the closure 14 adjacent the open top first end 18 of the container 12 define a maximum outer diameter which exceeds the inside diameter of the container 12. In one embodiment, the

closure 14 includes a pierceable resealable septum 28 penetrable by a needle cannula (not shown). Portions of the closure 14 extending downwardly from the bottom end 26 may taper from a minor diameter which is approximately equal to, or slightly less than, the inside diameter of the container 12 to a major diameter that is greater than the inside diameter of the container 12 at the top end 24. Thus, the bottom end 26 of the closure 14 may be urged into a portion of the container 12 adjacent the open top first end 18. The inherent resiliency of closure 14 can insure a sealing engagement with the inner surface 22 of the cylindrical sidewall 16 of the container 12. In one embodiment, the closure 14 can be formed of a unitarily molded elastomeric material, having any suitable size and dimensions to provide sealing engagement with the container 12. Optionally, the closure 14 may be at least partially surrounded by a shield, such as a Hemogard® Shield commercially available from Becton, Dickinson and Company.

[0037] Referring to FIGS. 3-10, a mechanical separator 30 of the present invention includes a separator body 32 including a first part 34 and a second part 36 interfaced to the first part 34. The first part 34 has a first density and the second part 36 has a second density, with the second density being different from the first density and, preferably, greater than the first density. Alternatively or in addition, the first part 34 has a first buoyancy and the second part 36 has a second buoyancy, with the second buoyancy being different from the first buoyancy and, preferably, less than the first buoyancy.

[0038] One of the first part 34 or the second part 36 of the mechanical separator 30 may be extruded and/or molded of a resiliently deformable and self-sealable material, such as a thermoplastic elastomer (TPE). Alternatively, one of the first part 34 or the second part 36 of the mechanical separator 30 may be extruded and/or molded of a resiliently deformable material that exhibits good sealing characteristics when contact is established with the container 12, as will be discussed herein. Maintenance of the density within the specified tolerances is more easily obtained by using a standard material that does not require compounding with, for example, hollow glass micro-spheres in order to reduce the material density. The other of the first part 34 or the second part 36 of the mechanical separator 30 can be formed from mineral filled polypropylene.

[0039] One of the first part 34 or the second part 36 of the mechanical separator 30 is made from a material having a density that is less than the less dense phase of the liquid or specimen intended to be separated into two phases. For example, if it is desired to separate serum and plasma from human blood, then it is desirable that one of the first part 34 or the second part 36 have a density of no more than about 1.020 g/cc.

[0040] The other of the first part 34 or the second part 36 of the mechanical separator 30 is made from a material having a higher density than the more dense phase of the liquid or sample intended to be separated into two phases. For example, if it is desired to separate human blood into serum and plasma, then it is desirable that the other of the first part 34 or the second part 36 have a density of at least 1.105 g/cc. It is anticipated herein that both the first part 34 and the second part 36 may be formed of various other materials with sufficient biocompatibility, density stability, additive compatibility, and neutrality to analyte interactions, adsorption, and leachability.

[0041] The mechanical separator 30 also includes a through-hole 38 defined therein, such as along a through-axis T of the separator body 32. As shown in FIGS. 3 and 5-7, the through-hole 38 may extend through the entire separator body 32 and includes a first opening 40 and a second opening 42 aligned along the through-axis T. The through-hole 38 may bisect or substantially bisect the volumetric center of the separator body 32. The through-hole 38 may be defined by at least a portion of the first part 34 and at least a portion of the second part 36.

[0042] The first part 34 has an exterior surface 44 that is generally arcuate in shape, such as at least partially rounded or substantially rounded. The second part 36 also includes an exterior surface 46 that is also generally arcuate in shape, such as at least partially rounded or substantially rounded. When taken together, the exterior surface 44 of the first part 34 and the exterior surface 46 of the second part 36 form a generally round exterior. It is understood herein that the term "round exterior" includes configurations, in addition to a perfect sphere, that are aspects of the invention which may provide slightly non-uniform diameters taken through the mid-point. For example, different planes taken through the first part 34 and second part 36 which bisect the midpoint of the mechanical separator 30 may have varying diameters and still give rise to a generally rounded or ball-like mechanical separator 30.

[0043] Due to the differential densities of the first part 34 and the second part 36, the mechanical separator 30 includes a center of mass M that is offset from the center of volume M1 of the separator body 32, as shown in FIG. 5. Specifically, the volume of the separator body 32 accounted for by the first part 34 may be significantly greater than the volume of the separator body 32 accounted for by the second part 36. Accordingly, the center of mass M of the separator body 32 may be offset from the center of the through-hole 38. Optionally, the center of volume M1 may also be offset from the center of the through-hole 38.

[0044] As shown in FIG. 4, the top profile of the separator body 32 may be non-circular. The diameter D₁ of the separator body 32, specifically the first part 34, taken across the first

part 34 in the direction along the through-axis T of the through-hole 38 and extending between vertically outermost opposing tangent points 48, 50 of a perimeter P of the separator body 32 is less than the diameter D₂ of the separator body 32, specifically the first part 34, taken across the first part 34 in the direction perpendicular to the through-axis T of the through-hole 38 and extending between laterally outermost opposing tangent points 52, 54 of the perimeter P of the separator body 32. In addition, the diameter D₃ of the separator body 32, specifically the first part 34, taken across the first part 34 at an angle of substantially 45° to the through-axis T of the through-hole 38 and extending between diagonally outermost endpoints 56, 58 of the perimeter P of the separator body 32, may be larger than the diameter of the through-hole 38, and is greater than the diameters D₁ and D₂ of the separator body 32. The diameter D₄ of the second part 36 taken across the second part 36 along the through-axis T of the through-hole 38, as shown in FIG. 6, may be less than any of the diameters D₁, D₂, or D₃ of the separator body 32.

[0045] Referring to FIG. 4, a two-dimensional projection of the top profile of the first part 34 of the separator body 32 onto a plane may be symmetrical about an orientation plane extending between vertically outermost opposing tangent points 48, 50 of the perimeter P of the separator body 32 and from the top surface of the first part 34 to the bottom surface of the second part 36 and extending in the direction of the through-axis T of the through-hole 38. The two-dimensional projection of the top profile of the first part 34 of the separator body 32 onto a plane may also be symmetrical about an orientation plane extending between laterally outermost opposing tangent points 52, 54 of the perimeter P of the separator body 32 and from the top surface of the first part 34 to the bottom surface of the second part 36 and perpendicular to the direction of the through-axis T of the through-hole 38. A two-dimensional projection of the top profile of the first part 34 of the separator body 32 onto a plane may be asymmetrical about an orientation plane extending between diagonally outermost endpoints 56, 58 of the perimeter P of the separator body 32 and from the top surface of the first part 34 to the bottom surface of the second part 36 and in a direction diagonal to at least a part of the through-axis T of the through-hole 38. Accordingly, a two-dimensional projection of the top profile of the body 32 onto a plane may be asymmetric about an orientation plane extending between diagonally outermost endpoints 56a, 58a of the perimeter P of the separator body and from the top surface of the first part 34 to the bottom surface of the second part 36 and in a direction diagonal to at least a part of the through-axis T of the through-hole 38.

[0046] Further, the top profile of the separator body 32 defines a perimeter P that bounds four quadrants A, B, C, D, respectively defined by the intersection of a vertical axis extending between vertically outermost opposing tangent points 48, 50 of the perimeter P of the separator body 32 and a lateral axis extending between laterally outermost opposing tangent points 52, 54 of the perimeter P of the separator body 32. Each quadrant A, B, C, D is substantially bisected by an orientation axis extending between diagonally outermost endpoints 56, 58 or 56a, 58a of the perimeter P of the separator body 32 and bounded by the perimeter P of the separator body 32 as shown in FIG. 4. A two-dimensional projection of the top profile of the separator body 32 onto a plane may be symmetrical about D₁ and D₂ but may be asymmetrical with respect to D₃.

[0047] Thus, the top surface of the first part 34 includes a first extended part 64 adjacent the first opening 40 of the through-hole 38 defined by tangent point 48, endpoint 56, and endpoint 58a and a second extended part 66 adjacent the second opening 42 of the through-hole 38 defined by tangent point 50, endpoint 56a, and endpoint 58, that taken with an upper part 68 of the first part 34, form a substantially non-circular convex top surface of the first part 34 (FIG. 7).

[0048] As shown in FIG. 8, in a first position, the mechanical separator 30 of the present invention is oriented within the container 12 in an initial position in which the through-axis T of the through-hole 38 of the mechanical separator 30 is in a plane that is not parallel to a plane containing the longitudinal axis L of the container 12. In this initial position, the through-hole 38 is adapted for allowing fluid to pass therethrough, such as from a needle cannula (not shown) which has pierced the pierceable septum 28 of the closure 14 and is provided in fluid communication with the interior 23 of the collection container 12. Further, since the through-axis T of the through-hole 38 of the mechanical separator 30 is offset with respect to the longitudinal axis L of the container 12, the second opening 42 of the through-hole 38 is located in close proximity to and adjacent the sidewall 16 of the longitudinal axis L of the container 12. This causes the fluid in this area to pass through the through-hole 38 and minimizes pooling of the fluid above and below the mechanical separator 30. This helps to reduce cellular damage to the fluid that can occur due to pooling of the fluid above the mechanical separator 30 as will be explained later.

[0049] In the first position, the through-axis T of the through-hole 38 is angled with respect to at least one of the longitudinal axis L of the container 12 and the sidewall 16 of the container 12. The angle θ of the through-axis T of the through-hole 38 with respect to the sidewall 16 of the container 12 may be from about 30° to about 60°.

[0050] Also, in the first position, the through-axis **T** of the through-hole **38** may be offset from the longitudinal axis **L** of the container **12**.

[0051] In one embodiment, the first part **34** may be a float and the second part **36** may be a ballast where the second part **36** has a second density that is greater than a first density of the first part **34**. The float **34** defines an upper surface **72** of the separator body **32** and the ballast **36** defines a lower surface **74** of the separator body **32**. In this embodiment, when the mechanical separator **30** is in the first position, the separator body **32** contacts the sidewall **16** of the container **12** at a location that is offset from a center of the upper surface **72** of the float **34**, and the separator body **32** contacts the sidewall **16** of the container **12** at a location that is offset from a center of the lower surface **74** of the ballast **36**.

[0052] In this embodiment, in the first position, a leading ballast portion **76** of the separator body **32** is provided adjacent the sidewall **16** of the container **12** and a trailing ballast portion **78** is spaced apart from the sidewall **16** of the container **12**.

[0053] In this position, a periphery **70** of the mechanical separator **30** forms an interference engagement with the sidewall **16** of the container **12** as shown in **FIG. 8**. In one configuration, the interference engagement may also form a seal with the sidewall **16** of the container **12**.

[0054] Upon application of rotational force, such as during centrifuge, and transition of the mechanical separator **30** as shown in **FIG. 9**, the mechanical separator **30** experiences a rotational moment, deforms sufficiently to disengage from the first position engagement with the container **12**, and rotates in a clockwise direction. In the embodiment, shown in **FIGS. 8-10**, where the first part **34** is a float and the second part **36** is a ballast, the mechanical separator **30** will be oriented with the second part **36** facing the bottom closed second end **20** of the container **12**.

[0055] Once the mechanical separator **30** contacts the fluid contained within the container **12**, air that occupies the through-hole **38** is progressively displaced by the fluid as the device submerges. When the mechanical separator **30** is submerged in the fluid, the difference in the buoyancy between the first part **34** and the second part **36** generates a differential force across the mechanical separator **30**. During centrifugation, the differential force causes the separator body **32** to elongate and contract away from the sidewall **16** of the collection container **12**, thereby reducing the effective diameter of the separator body **32** and opening a communicative pathway for the flow of fluid, such as higher and lower density phase components, past the separator body **32**. It is noted that the first part **34** may be adapted for deformation in directions substantially perpendicular to the through-hole **38**.

[0056] Because, in the first position, the through-axis **T** of the through-hole **38** is offset from the longitudinal axis **L** of the container **12**, upon introduction of the fluid into the container **12**, there is little or no pooling of fluid in an area **86** adjacent to the contact point between the second portion **36** of the mechanical separator **30** and the sidewall **16** of the container **12**. This is also the case for the pooling of fluid that would occur in an area **86a** adjacent to the contact point between the first portion **34** of the mechanical separator **30** and a sidewall **16** of the container **12**. Further, during rotation, the mechanical separator **30** only minimally contacts or does not contact at all any pooled fluid in this area **86**. Therefore, the pooled fluid is not subjected to any forces from the mechanical separator **30** that could cause cellular damage to the fluid.

[0057] Likewise, in the first position, while some fluid may pool in an area **88** adjacent to the contact point between the first portion **34** of the mechanical separator **30** and the sidewall **16** of the container **12**, during rotation, very little of the mechanical separator **30** will contact the pooled fluid in this area **88**, and the pooled fluid is not subjected to any forces from the mechanical separator **30** that could cause cellular damage to the fluid.

[0058] Once the application of rotational force has ceased, the mechanical separator **30** becomes oriented between a separated higher density phase **80** and a separated lower density phase **82** in a second sealing position (FIG. 10). At the same time, the elongation of the separator body **32** ceases, causing the separator body **32** to return to its initial configuration, thereby forming a seal where the separator body **32** contacts the sidewall **16** of the container **12** at at least part of a periphery **84** of the upper surface **72** of the separator body **32**. The separator body **32** may contact the sidewall **16** of the container **12** at the entire periphery **84** of the upper surface **72** of the separator body **32**. In the embodiment where the first part **34** is a float, the periphery **84** of the upper surface **72** is part of the float. In this position, the through-hole **38** is substantially perpendicular to longitudinal axis **L** of the container **12**.

[0059] The periphery **84** of the upper surface **72** of the separator body **32** has an outer circumference that is at least slightly larger than the corresponding interior circumference of the sidewall **16** of the container **12**. In addition, the smallest diameter **D₁** of the top surface of the first part **34** is at least slightly greater than the corresponding diameter of the inner surface **22** of the container **12**. Accordingly, the mechanical separator **30** is adapted to prevent fluid from passing between or around the separator body **32** and the container **12**, and also prevents fluid from passing through the through-hole **38**, effectively establishing a barrier and the periphery **84** of the upper surface **72** of the separator body **32** establishes a barrier between higher and lower density phases **80**, **82** within the sample.

[0060] As can be determined from the discussion above, the separator body 32 is in a compressed, but substantially unstressed state when it forms a seal with the interior surface 22 of the sidewall 16 of the container 12. The shape of the top profile of the separator body 32 provides for this compression to form a tight seal with the interior surface 22 of the sidewall 16 of the container 12. The interior surface 22 of the sidewall 16 of the container 12 has a first shape that is substantially circular, while the separator body 32 has a top surface that defines a second periphery shape 84 that is non-circular in the uncompressed state.

[0061] While the present invention is described with reference to several distinct embodiments of a mechanical separator assembly and method of use, those skilled in the art may make modifications and alterations without departing from the scope and spirit. Accordingly, the above detailed description is intended to be illustrative rather than restrictive.

THE INVENTION CLAIMED IS:

1. A separation assembly for enabling separation of a fluid into first and second parts, comprising:

a container having a first end, a second end, and a sidewall extending therebetween having an inner surface and defining a container interior, the container defining a longitudinal axis between the first end and the second end; and

a separator body disposed within the container interior and having a through-hole defined therethrough, the separator body comprising:

a first part; and

a second part interfaced with the first part,

wherein the separator body is transitionable from a first position in which the through-hole is provided in fluid-receiving alignment with the first end of the container, to a second position in which the through-hole is provided substantially perpendicular to the longitudinal axis of the container, and

wherein, in the first position, a through-axis of the through-hole of the separator body is in a plane that is not parallel with a plane containing the longitudinal axis of the container.

2. The separation assembly of claim 1, wherein the first part of the separator body is a float and the float defines an upper surface of the separator body, and the second part of the separator body is a ballast and the ballast defines a lower surface of the separator body.

3. The separation assembly of claim 2, wherein when the separator body is in the first position, the separator body contacts the sidewall of the container at a location that is offset from a center of the upper surface of the float.

4. The separation assembly of claim 2, wherein when the separator body is in the first position, the separator body contacts the sidewall of the container at a location that is offset from a center of the lower surface of the ballast.

5. The separation assembly of claim 2, wherein when in the second position, the separator body contacts the sidewall of the container at at least part of a periphery of the upper surface of the float.

6. The separation assembly of claim 2, wherein when in the second position, the separator body contacts the sidewall of the container at the entire periphery of the upper surface of the float.

7. The separation assembly of claim 1, wherein a part of the first part of the separator body and a part of the second part of the separator body define the through-hole.

8. The separation assembly of claim 1, wherein the first part of the separator body defines the through-hole.

9. A separation assembly for enabling separation of a fluid into first and second parts, comprising:

a container having a first end, a second end, and a sidewall extending therebetween having an inner surface and defining a container interior, the container defining a longitudinal axis between the first end and the second end; and

a separator body disposed within the container interior and having a through-hole defined therethrough, the separator body comprising:

a first part; and

a second part interfaced with the first part,

wherein the separator body is transitionable from a first position in which the through-hole is provided in fluid-receiving alignment with the first end of the container, to a second position in which the through-hole is provided substantially perpendicular to the longitudinal axis of the container, and

wherein, in the first position, a through-axis of the through-hole is angled with respect to at least one of the longitudinal axis of the container and the sidewall of the container.

10. The separation assembly of claim 9, wherein, in the first position, the through-axis of the through-hole is angled from about 30° to about 60° with respect to the sidewall of the container.

11. The separation assembly of claim 9, wherein the first part of the separator body is a float and the float defines an upper surface of the separator body, and the second part of the separator body is a ballast and the ballast defines a lower surface of the separator body.

12. The separation assembly of claim 11, wherein when in the first position, the separator body contacts the sidewall of the container at a location that is offset from a center of the upper surface of the float.

13. The separation assembly of claim 11, wherein when in the first position, the separator body contacts the sidewall of the container at a location that is offset from a center of the lower surface of the ballast.

14. The separation assembly of claim 11, wherein when in the second position, the separator body contacts the sidewall of the container at at least part of a periphery of the upper surface of the float.

15. The separation assembly of claim 11, wherein when in the second position, the separator body contacts the sidewall of the container at the entire periphery of the upper surface of the float.

16. The separation assembly of claim 9, wherein a part of the first part of the separator body and a part of the second part of the separator body define the through-hole.

17. The separation assembly of claim 9, wherein the first part of the separator body defines the through-hole.

18. A separation assembly for enabling separation of a fluid into first and second parts, comprising:

a container having a first end, a second end, and a sidewall extending therebetween having an inner surface and defining a container interior, the container defining a longitudinal axis between the first end and the second end; and

a separator body disposed within the container interior and having a through-hole for fluid to pass therethrough, the separator body comprising:

a first part; and

a second part interfaced with the first part,

wherein the separator body is transitionable from a first position in which the through-hole is provided in fluid-receiving alignment with the first end of the container, to a second position in which the through-hole is provided substantially perpendicular to the longitudinal axis of the container, and

wherein, in the first position, a through-axis of the through-hole of the separator body is offset from the longitudinal axis of the container.

19. The separation assembly of claim 18, wherein the first part of the separator body is a float and the float defines an upper surface of the separator body, and the second part of the separator body is a ballast and the ballast defines a lower surface of the separator body.

20. The separation assembly of claim 19, wherein, when in the first position, the separator body contacts the sidewall of the container at a location that is offset from a center of the upper surface of the float.

21. The separation assembly of claim 19, wherein, when in the first position, the separator body contacts the sidewall of the container at a location that is offset from a center of the lower surface of the ballast.

22. The separation assembly of claim 19, wherein when in the second position, the separator body contacts the sidewall of the container at at least part of a periphery of the upper surface of the float.

23. The separation assembly of claim 19, wherein when in the second position, the separator body contacts the sidewall of the container at the entire periphery of the upper surface of the float.

24. The separation assembly of claim 18, wherein a part of the first part of the separator body and a part of the second part of the separator body define the through-hole.

25. The separation assembly of claim 18, wherein the first part of the separator body defines the through-hole.

26. A separation assembly for enabling separation of a fluid into first and second parts, comprising:

a container having a first end, a second end, and a sidewall extending therebetween having an inner surface and defining a container interior, the container defining a longitudinal axis between the first end and the second end; and

a separator body disposed within the container interior and having a through-hole defined therethrough, the separator body comprising:

a float; and

a ballast, wherein the float and the ballast are connected, the ballast defining a leading ballast part and a trailing ballast part,

wherein the separator body is transitionable from a first position in which the through-hole is provided in fluid-receiving alignment with the first end of the container, to a second position in which the through-hole is provided substantially perpendicular to the longitudinal axis of the container, and

wherein, in the first position, the leading ballast part of the separator body is provided adjacent the sidewall of the container and the trailing ballast part is spaced apart from the sidewall of the container.

27. The separation assembly of claim 26, wherein the float defines a leading float part and a trailing float part, and wherein in the first position, the trailing float part and the leading ballast part of the separator body are provided adjacent the sidewall of the container, and the leading float part and the trailing ballast part are spaced away from the sidewall of the container.

1/7

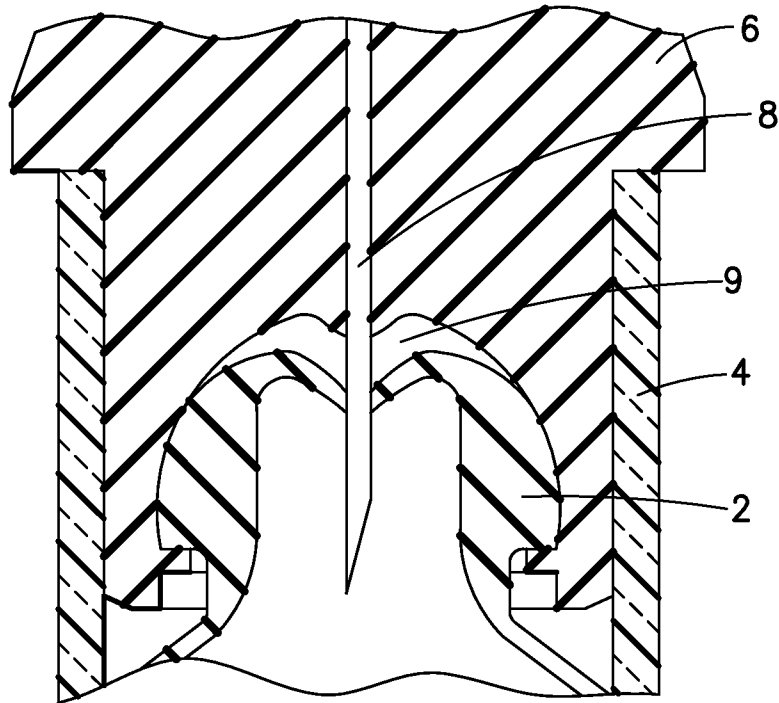

FIG. 1
PRIOR ART

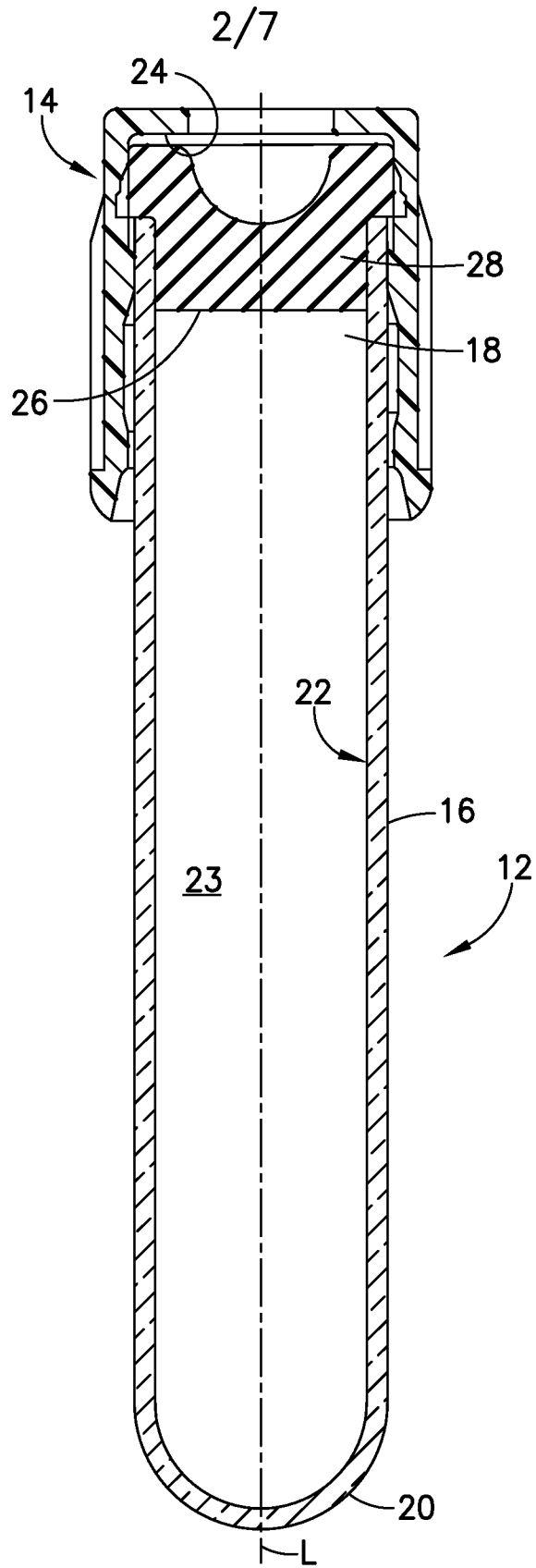

FIG.2

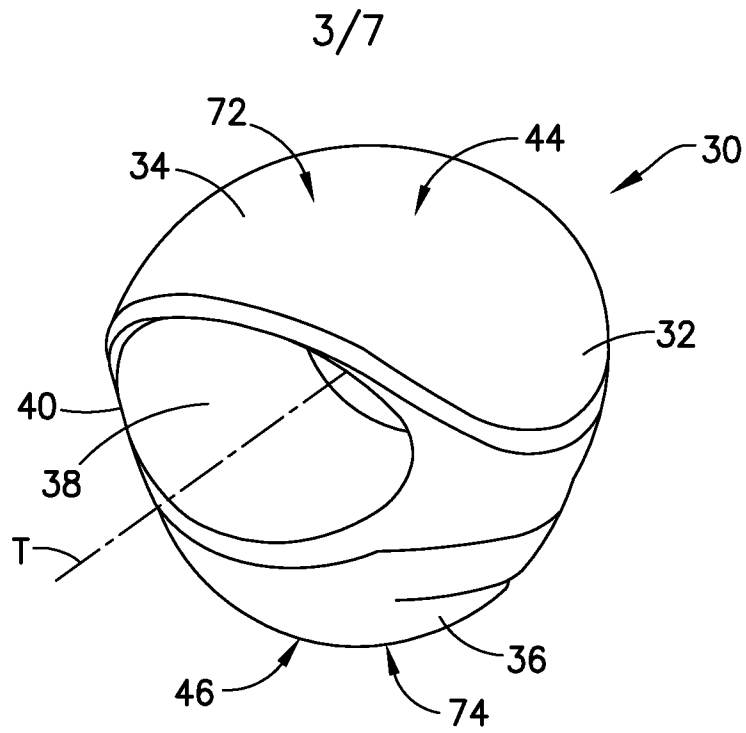

FIG. 3

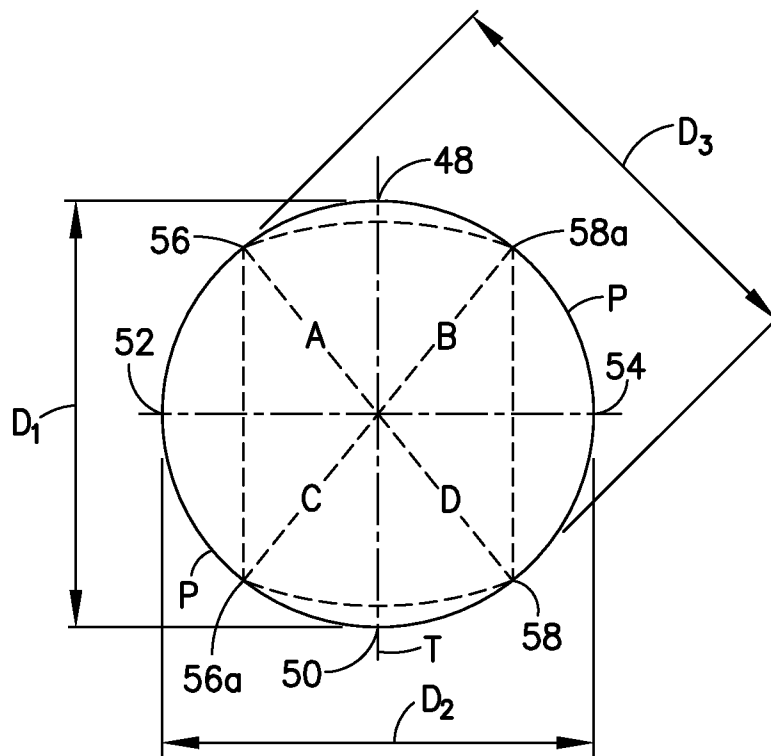

FIG. 4

4/7

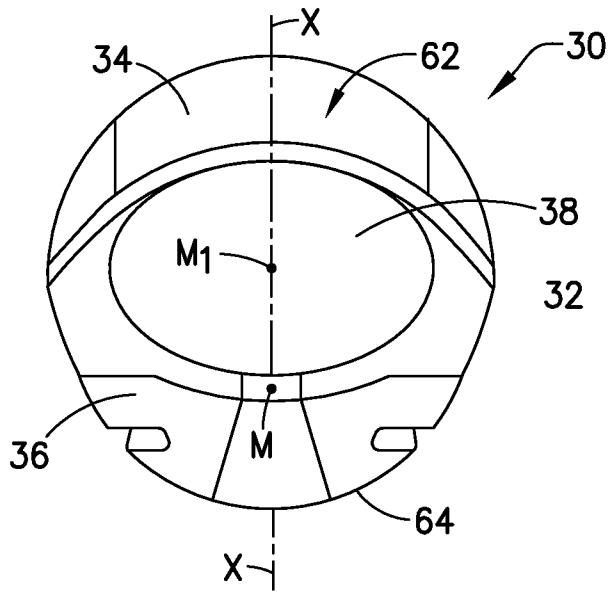

FIG. 5

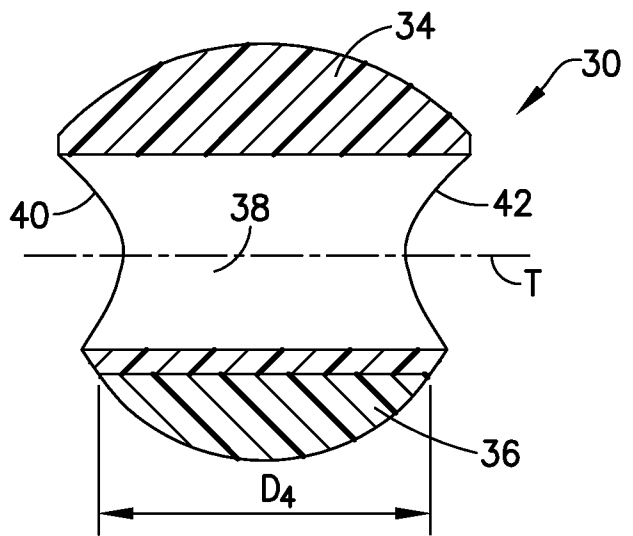

FIG. 6

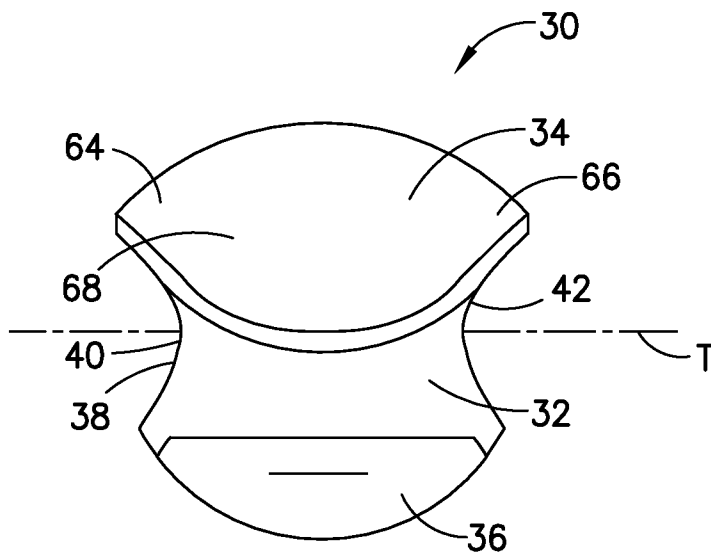

FIG. 7

5/7

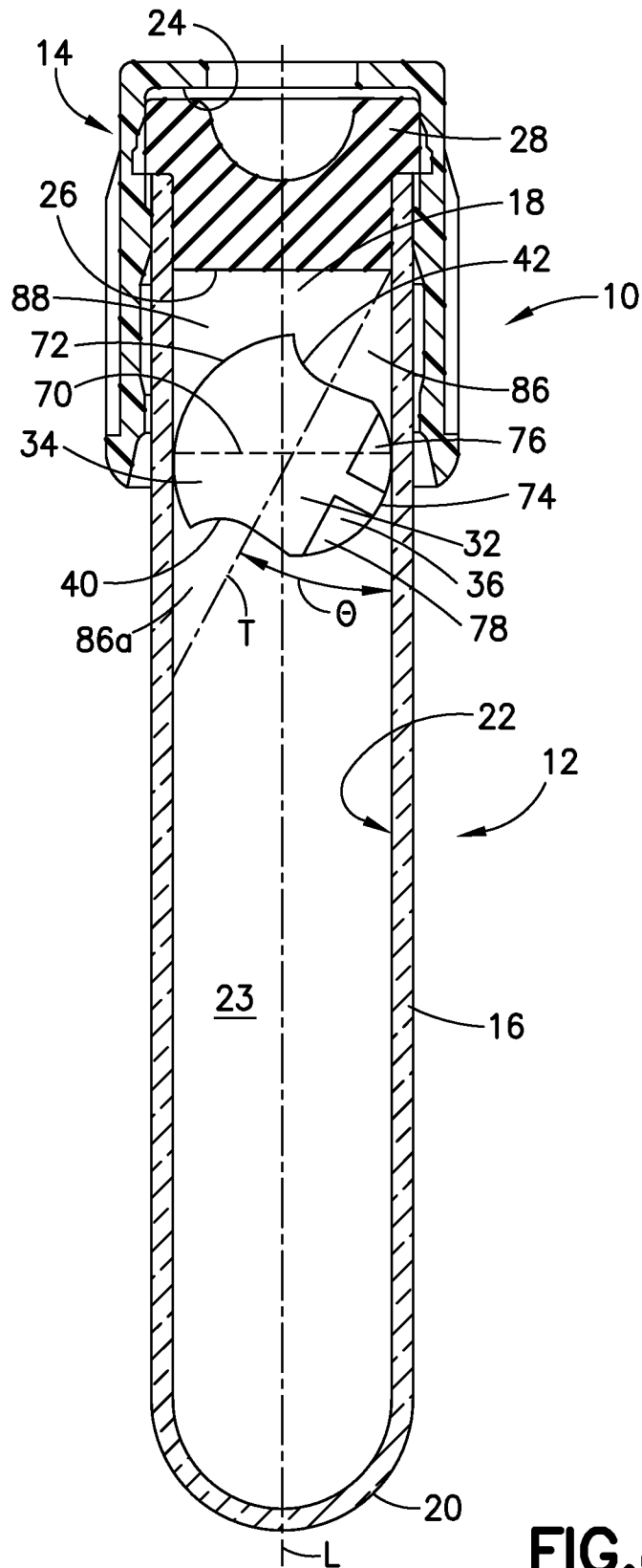

FIG.8

6/7

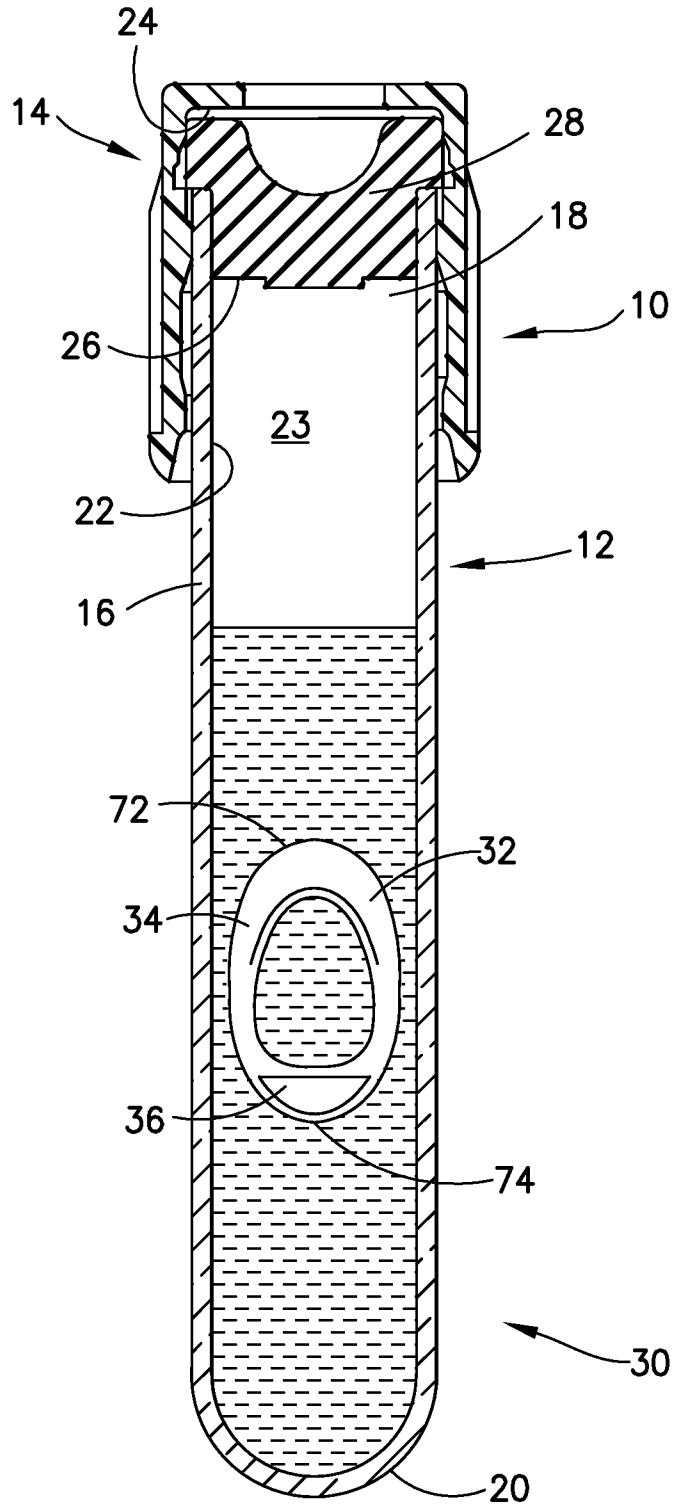

FIG.9

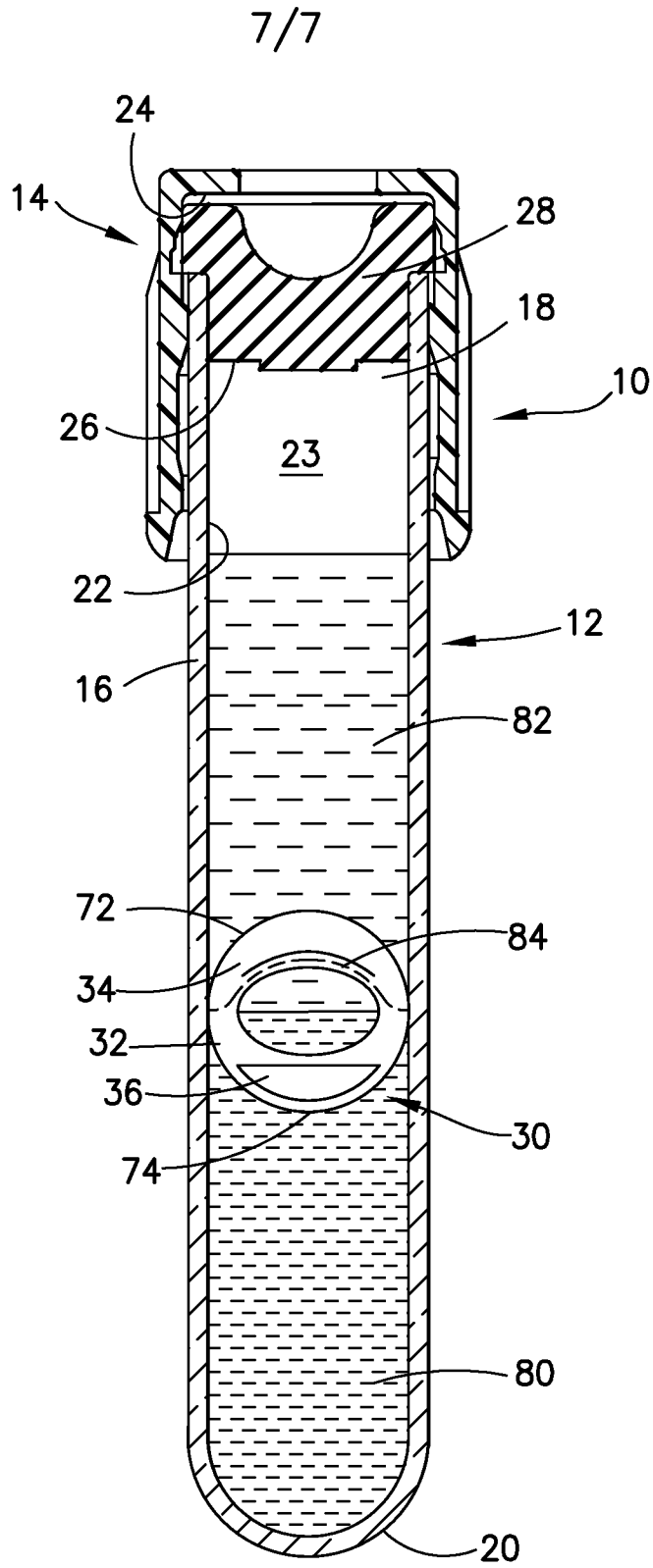

FIG.10

INTERNATIONAL SEARCH REPORT

International application No
PCT/US2015/020797

A. CLASSIFICATION OF SUBJECT MATTER
 INV. B01L3/00 B01L3/14
 ADD.
 According to International Patent Classification (IPC) or to both national classification and IPC

B. FIELDS SEARCHED
 Minimum documentation searched (classification system followed by classification symbols)
 B01L
 Documentation searched other than minimum documentation to the extent that such documents are included in the fields searched

Electronic data base consulted during the international search (name of data base and, where practicable, search terms used)
 EPO-Internal, WPI Data

C. DOCUMENTS CONSIDERED TO BE RELEVANT		
Category*	Citation of document, with indication, where appropriate, of the relevant passages	Relevant to claim No.
X	US 2010/288694 A1 (CRAWFORD JAMIESON W [US] ET AL) 18 November 2010 (2010-11-18) paragraphs [0012] - [0018] paragraphs [0146] - [0149] paragraph [0009]	1-27
X	WO 2014/039498 A1 (BECTON DICKINSON CO [US]) 13 March 2014 (2014-03-13) paragraphs [0059] - [0075]; figures 1-11	1-27
A	US 5 632 905 A (HAYNES JOHN L [US]) 27 May 1997 (1997-05-27) the whole document	1-27

Further documents are listed in the continuation of Box C.

See patent family annex.

* Special categories of cited documents :

- "A" document defining the general state of the art which is not considered to be of particular relevance
- "E" earlier application or patent but published on or after the international filing date
- "L" document which may throw doubts on priority claim(s) or which is cited to establish the publication date of another citation or other special reason (as specified)
- "O" document referring to an oral disclosure, use, exhibition or other means
- "P" document published prior to the international filing date but later than the priority date claimed

- "T" later document published after the international filing date or priority date and not in conflict with the application but cited to understand the principle or theory underlying the invention
- "X" document of particular relevance; the claimed invention cannot be considered novel or cannot be considered to involve an inventive step when the document is taken alone
- "Y" document of particular relevance; the claimed invention cannot be considered to involve an inventive step when the document is combined with one or more other such documents, such combination being obvious to a person skilled in the art
- "&" document member of the same patent family

Date of the actual completion of the international search
 24 June 2015

Date of mailing of the international search report
 08/07/2015

Name and mailing address of the ISA/
 European Patent Office, P.B. 5818 Patentlaan 2
 NL - 2280 HV Rijswijk
 Tel. (+31-70) 340-2040,
 Fax: (+31-70) 340-3016

Authorized officer
 Tiede, Ralph

INTERNATIONAL SEARCH REPORT

International application No.
PCT/US2015/020797

Box No. II Observations where certain claims were found unsearchable (Continuation of item 2 of first sheet)

This international search report has not been established in respect of certain claims under Article 17(2)(a) for the following reasons:

1. Claims Nos.:
because they relate to subject matter not required to be searched by this Authority, namely:

2. Claims Nos.:
because they relate to parts of the international application that do not comply with the prescribed requirements to such an extent that no meaningful international search can be carried out, specifically:

3. Claims Nos.:
because they are dependent claims and are not drafted in accordance with the second and third sentences of Rule 6.4(a).

Box No. III Observations where unity of invention is lacking (Continuation of item 3 of first sheet)

This International Searching Authority found multiple inventions in this international application, as follows:

see additional sheet

1. As all required additional search fees were timely paid by the applicant, this international search report covers all searchable claims.
2. As all searchable claims could be searched without effort justifying an additional fees, this Authority did not invite payment of additional fees.
3. As only some of the required additional search fees were timely paid by the applicant, this international search report covers only those claims for which fees were paid, specifically claims Nos.:

4. No required additional search fees were timely paid by the applicant. Consequently, this international search report is restricted to the invention first mentioned in the claims; it is covered by claims Nos.:

Remark on Protest

- The additional search fees were accompanied by the applicant's protest and, where applicable, the payment of a protest fee.
- The additional search fees were accompanied by the applicant's protest but the applicable protest fee was not paid within the time limit specified in the invitation.
- No protest accompanied the payment of additional search fees.

FURTHER INFORMATION CONTINUED FROM PCT/ISA/ 210

This International Searching Authority found multiple (groups of) inventions in this international application, as follows:

1. claims: 1-27

Container with a separation body

1.1. claims: 1-8

Container with a separation body and wherein, in the first position of said body, a through-axis of the through-hole of the separator body is in a plane that is not parallel with a plane containing the longitudinal axis of the container.

1.2. claims: 9-17

Container with a separation body and wherein, in the first position of said body, in the first position, a through-axis of the through-hole is angled with respect to at least one of the longitudinal axis of the container and the sidewall of the container.

1.3. claims: 18-25

Container with a separation body and wherein, in the first position of said body, a through-axis of the through-hole of the separator body is offset from the longitudinal axis of the container.

1.4. claims: 26, 27

Container with a separation body with a float and a ballast and wherein, in the first position of said body, a leading ballast part of the separator body is provided adjacent the sidewall of the container and a trailing ballast part is spaced apart from the sidewall of the container.

INTERNATIONAL SEARCH REPORT

Information on patent family members

International application No

PCT/US2015/020797

Patent document cited in search report	Publication date	Patent family member(s)	Publication date
US 2010288694	A1	18-11-2010	AU 2010248856 A1
			CA 2762131 A1
			CA 2856509 A1
			CA 2856511 A1
			CA 2856517 A1
			CA 2856536 A1
			CN 102458661 A
			CN 104190487 A
			EP 2429708 A1
			JP 5638603 B2
			JP 2012526994 A
			JP 2015062018 A
			KR 20120014926 A
			NZ 596537 A
			RU 2012154558 A
			SG 176028 A1
			US 2010288694 A1
			US 2013313189 A1
			US 2013315798 A1
			US 2013315799 A1
			US 2013323141 A1
			US 2015104359 A1
			US 2015168279 A1
			US 2015168280 A1
			WO 2010132783 A1

WO 2014039498	A1	13-03-2014	EP 2892648 A1
			WO 2014039498 A1

US 5632905	A	27-05-1997	NONE
